

138'-0¹⁵/₁₆" (ALONG CHORD)
 (FILL FACE @ END BENT #1 TO FILL FACE @ END BENT #2)

* RADIAL DIMENSION
 ▼ THESE BARS ARE TO BE PARALLEL TO THE SKEW.

PLAN OF SPAN "A"

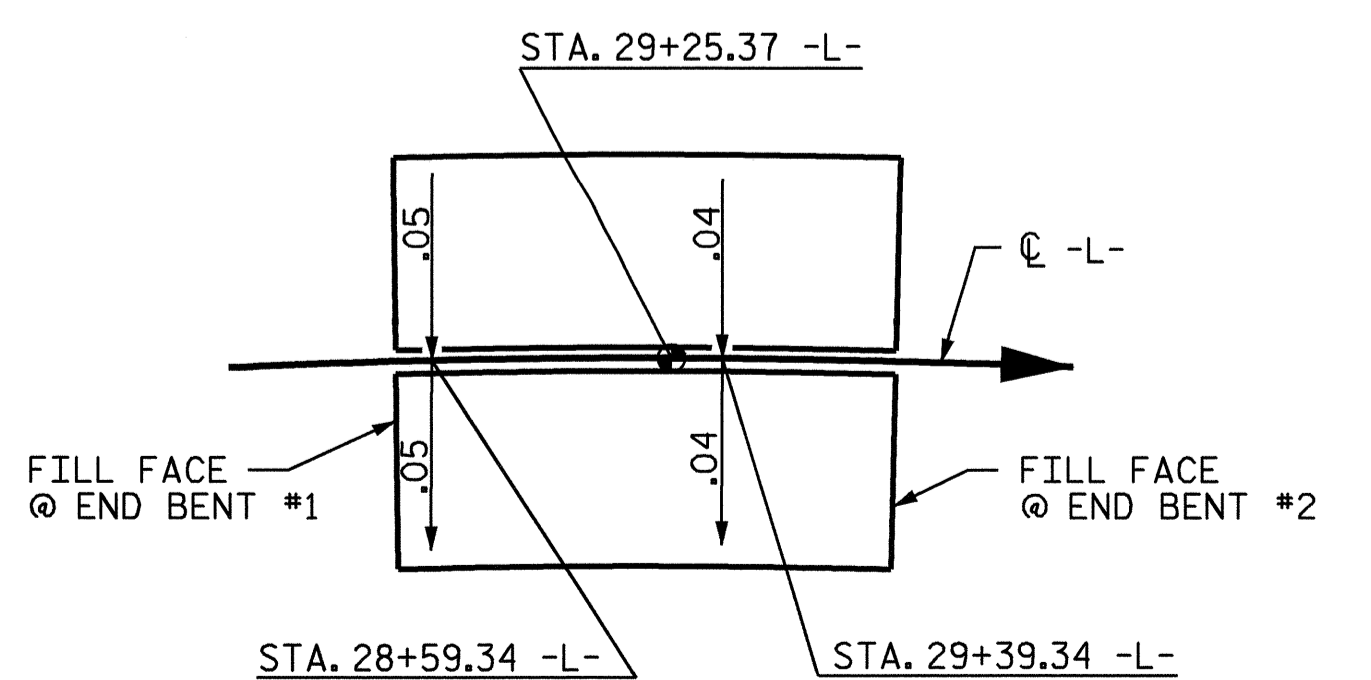
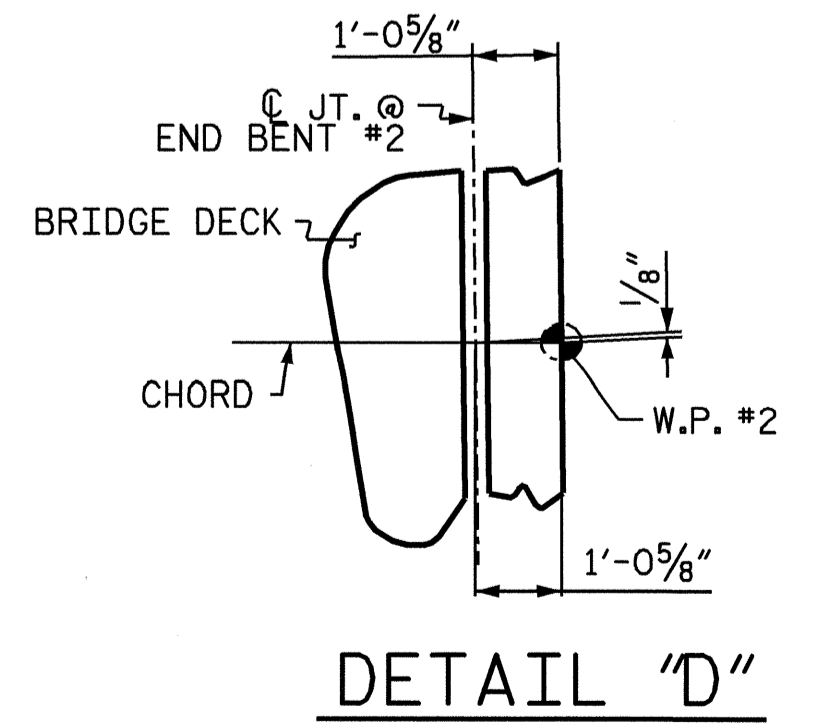
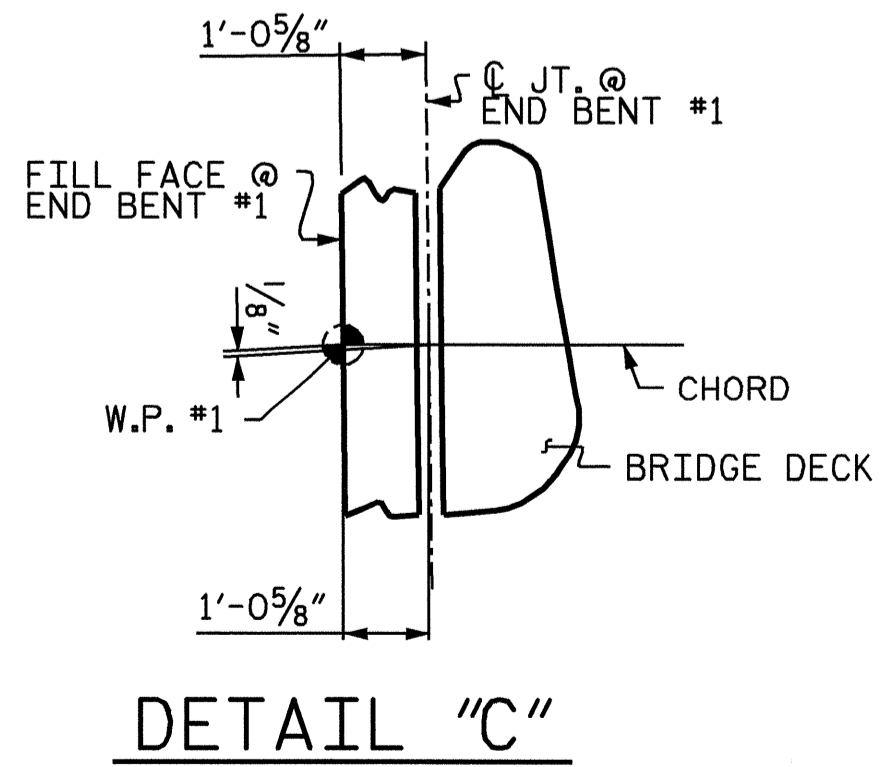

VARIABLE SUPERELEVATION SKETCH

PROJECT NO. B-3157
DAVIDSON COUNTY
 STATION: 29+25.37 -L-

SHEET 1 OF 2

STATE OF NORTH CAROLINA DEPARTMENT OF TRANSPORTATION RALEIGH					
SUPERSTRUCTURE PLAN OF SPAN "A"					
LEFT LANE					
REVISIONS					
NO.	BY:	DATE:	NO.	BY:	DATE:
1			3		
2			4		
					SHEET NO. S-7
					TOTAL SHEETS 56

EMILY E. MARRIY
 ENGINEER
 SEAL 025516
 6/29/04

DRAWN BY : PEGGY ADKINS DATE : 2-03
 CHECKED BY : M. M. PARSONS DATE : 5-03