

SECTION A-A

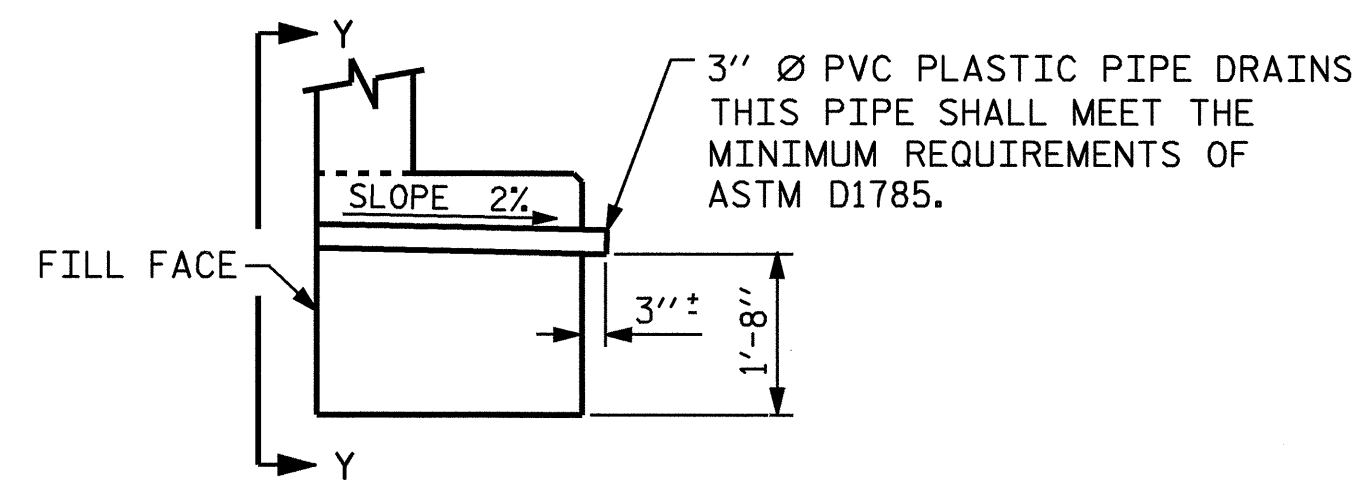

SECTION THRU CAP

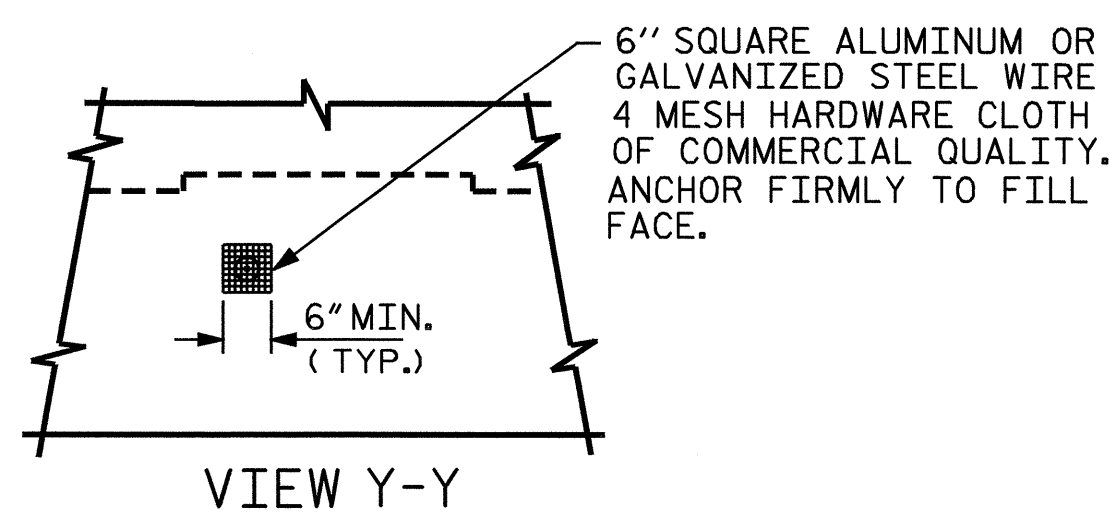

VIEW Y-Y

NOTE: NO SEPARATE PAYMENT WILL BE MADE FOR FURNISHING AND INSTALLING THE PVC PLASTIC PIPE DRAINS, HARDWARE CLOTH AND FASTENERS. THE ENTIRE COST OF THIS WORK SHALL BE INCLUDED IN THE UNIT CONTRACT PRICE BID FOR THE SEVERAL PAY ITEMS.

PIPE DRAIN DETAILS

DRAWN BY : G.M.Patterson DATE : 11/12/03
 CHECKED BY : D.A. GLADDEN DATE : 01/29/04

27-JUL-2004 07:58
 W:\squad\U0620\Str2and3\mpatterson\Microstation\U0620.sd_e2.02.dgn
 klappenbach

BAR TYPES

ALL BAR DIMENSIONS ARE OUT TO OUT.

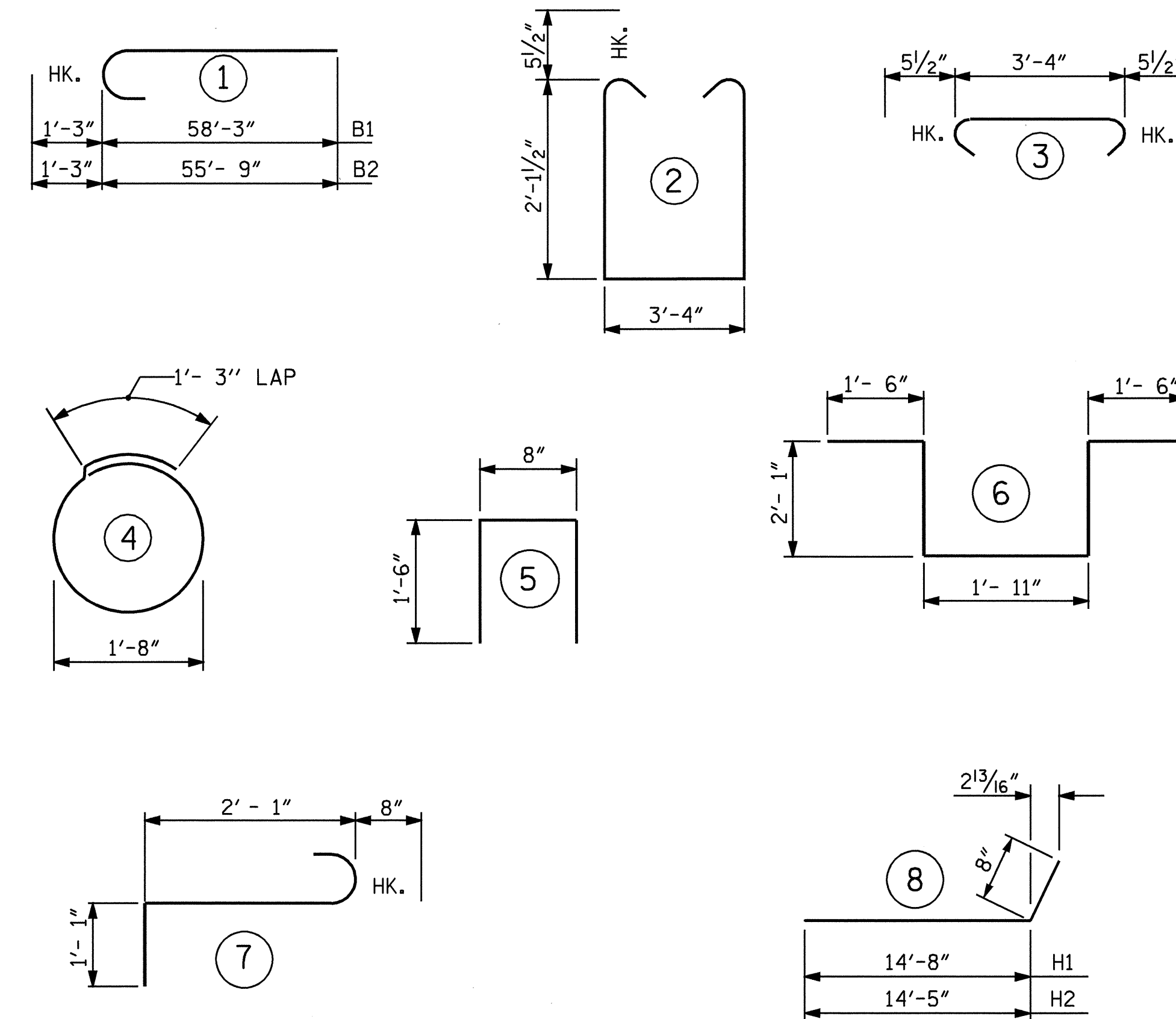

BILL OF MATERIAL

| REINFORCING STEEL BAR SCHEDULE | | | | | |
|--------------------------------|-----|------|------|--------|--------|
| BAR | NO. | SIZE | TYPE | LENGTH | WEIGHT |
| B1 | 5 | 9 | 1 | 59- 6 | 1012 |
| B2 | 5 | 9 | 1 | 57- 0 | 969 |
| B3 | 2 | 5 | STR | 52- 7 | 110 |
| B4 | 8 | 4 | STR | 27- 2 | 145 |
| B5 | 12 | 4 | STR | 3- 4 | 27 |
| | | | | | |
| H1 | 11 | 5 | 8 | 15- 4 | 176 |
| H2 | 11 | 5 | 8 | 15- 1 | 173 |
| | | | | | |
| K1 | 12 | 5 | STR | 52- 7 | 658 |
| K2 | 4 | 5 | STR | 4- 2 | 17 |
| K3 | 1 | 5 | STR | 8- 5 | 9 |
| K4 | 1 | 5 | STR | 8- 2 | 9 |
| | | | | | |
| S1 | 60 | 5 | 2 | 8- 6 | 532 |
| S2 | 60 | 5 | 3 | 4- 3 | 266 |
| S3 | 16 | 4 | 4 | 6- 6 | 69 |
| S4 | 1 | 6 | 6 | 9- 1 | 14 |
| S5 | 3 | 6 | 7 | 3-10 | 17 |
| | | | | | |
| U1 | 40 | 4 | 5 | 3- 8 | 98 |
| | | | | | |
| V1 | 80 | 5 | STR | 8- 2 | 681 |
| V2 | 16 | 5 | STR | 9- 7 | 160 |
| V3 | 8 | 5 | STR | 9- 8 | 81 |
| V4 | 8 | 5 | STR | 9-10 | 82 |
| V5 | 8 | 5 | STR | 10- 0 | 83 |
| V6 | 12 | 5 | STR | 9- 5 | 118 |
| | | | | | |
| REINFORCING STEEL (LBS.) | | | | | 5,506 |
| | | | | | |
| CLASS A CONCRETE (CU.YDS.) | | | | | |
| POUR #1 | | | | | = 18.8 |
| POUR #2 | | | | | = 15.4 |
| TOTAL | | | | | = 34.2 |
| | | | | | |
| HP12 X 53 STEEL PILES | | | | | |
| NO. 11 LIN.FT. 815 | | | | | |

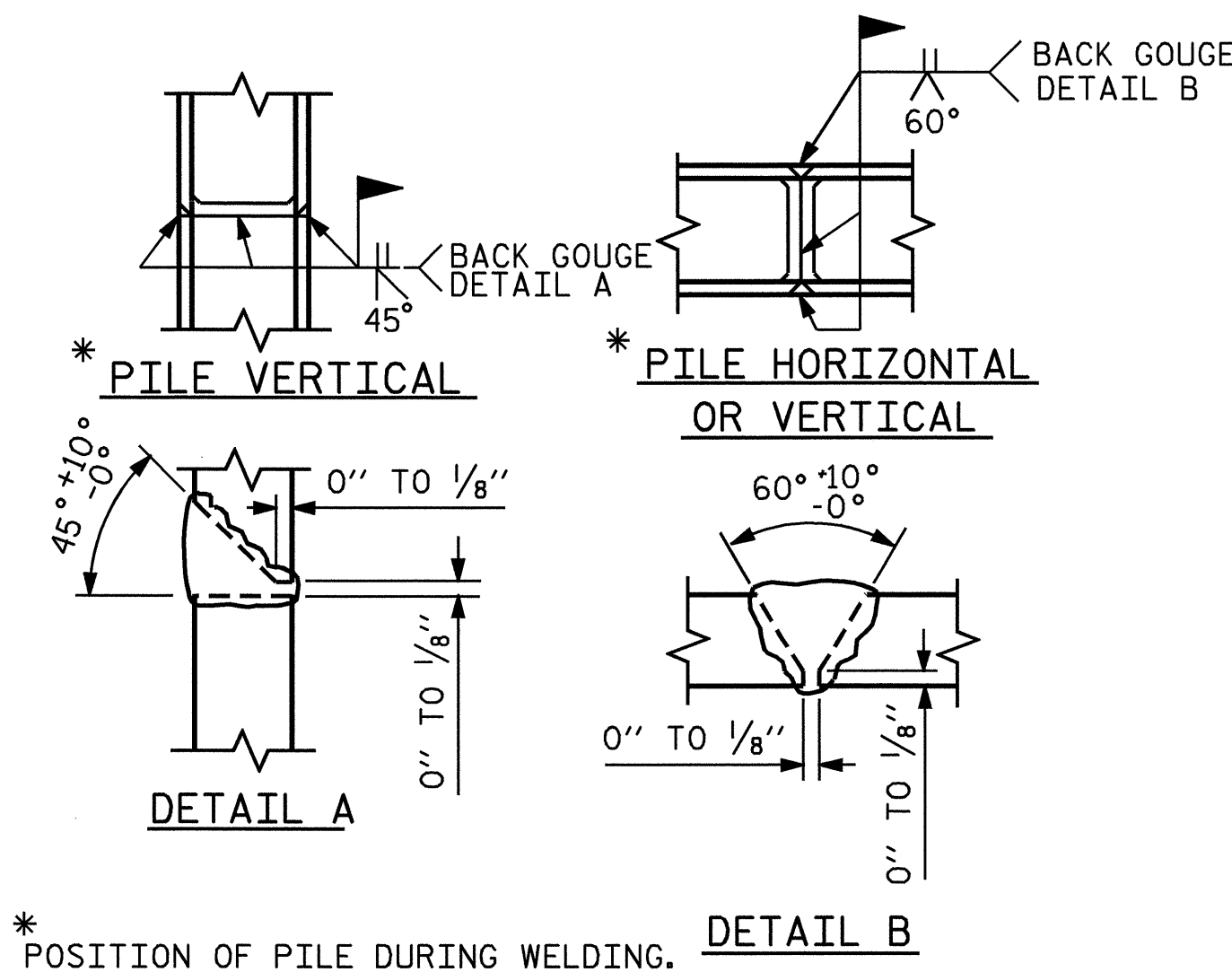

PILE SPLICE DETAILS

PROJECT NO. U-0620
CUMBERLAND COUNTY
 STATION: 161+95.29 -L-

SHEET 3 OF 3

STATE OF NORTH CAROLINA
 DEPARTMENT OF TRANSPORTATION
 RALEIGH

SUBSTRUCTURE
 END BENT 2
 (LEFT LANE)

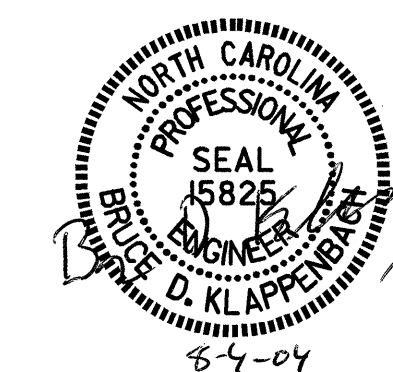

| REVISIONS | | | | | SHEET NO. |
|-----------|-----|-------|-----|-----|-----------|
| NO. | BY: | DATE: | NO. | BY: | DATE: |
| 1 | | | 3 | | |
| 2 | | | 4 | | |

STR #2