

**HORIZONTAL CURVE DATA**

PI. STA. 172+07.60  
 $\Delta = 51^\circ-28'-19.8"$  (RT)  
 $D = 2^\circ-00'-00"$   
 $L = 2573.61'$   
 $T = 1380.95'$   
 $R = 2864.789'$   
 $SE = 0.035$

-3.7515% +3.3926%  
 P. I. = 151+00.00 -L-  
 EL. = 151.11  
 V. C. = 750'  
 GRADE DATA -L-

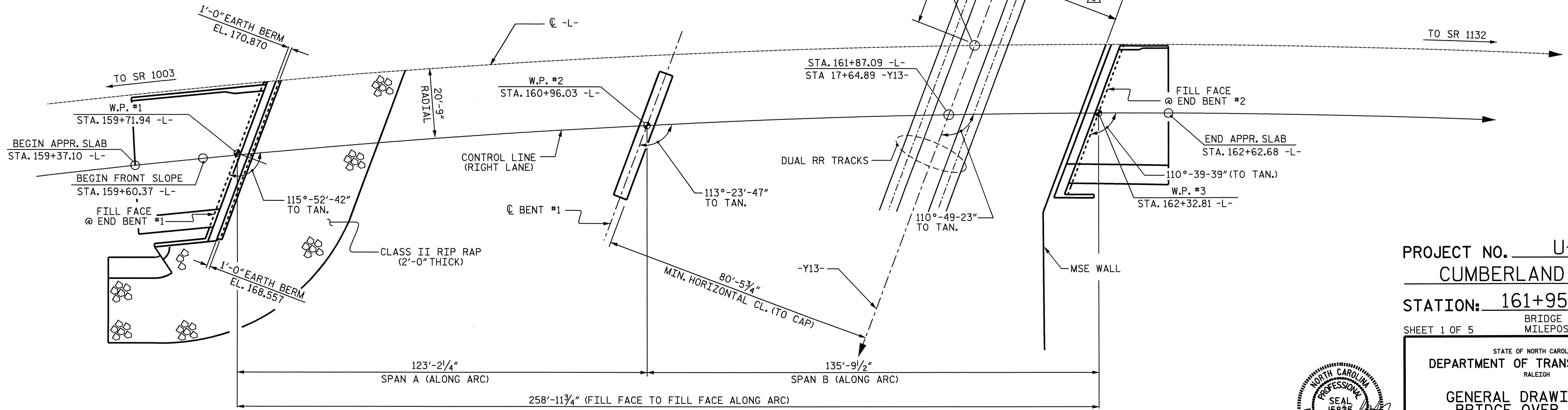

PROJECT NO. U-0620  
CUMBERLAND COUNTY  
 STATION: 161+95.29 -L-  
 BRIDGE No. 347  
 MILEPOST A-215.60  
 SHEET 1 OF 5

STATE OF NORTH CAROLINA  
 DEPARTMENT OF TRANSPORTATION  
 RALEIGH  
 GENERAL DRAWING FOR  
 BRIDGE OVER CSX RR  
 ON HOPE MILLS  
 BYPASS BETWEEN  
 SR 1003 AND SR 1132  
 (RIGHT LANE)

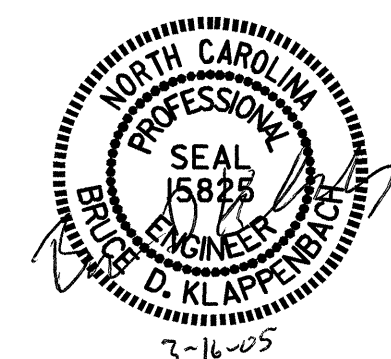

REVISION : REVISED MINIMUM HORIZONTAL CLEARANCE.  
 CHANGE BRACE PILES TO VERTICAL PILES AT END BENT #2.  
 BY : JBW CHECKED BY : BDK

DRAWN BY : M. G. SHAIKH DATE : 11-20-02  
 CHECKED BY : A. K. PASCHAL DATE : 12-12-02

REVISIONS					SHEET NO.
NO.	BY:	DATE:	NO.	BY:	DATE:
1	JBW	3/14/05	3		
2			4		

TOTAL SHEETS 129