



STATE OF NORTH CAROLINA
DEPT. OF TRANSPORTATION
DIVISION OF HIGHWAYS
RALEIGH, N.C.

STATE OF NORTH CAROLINA
DEPT. OF TRANSPORTATION
DIVISION OF HIGHWAYS
RALEIGH, N.C.

METRIC DETAIL DRAWING FOR
MILLED RUMBLE STRIPS
FOR 1.2m OUTSIDE SHOULDER ON
AT GRADE INTERSECTIONS

METRIC DETAIL DRAWING FOR
MILLED RUMBLE STRIPS
FOR 1.2m OUTSIDE SHOULDER ON
AT GRADE INTERSECTIONS

SHEET 1 OF 1
665D01

SHEET 1 OF 1
665D01

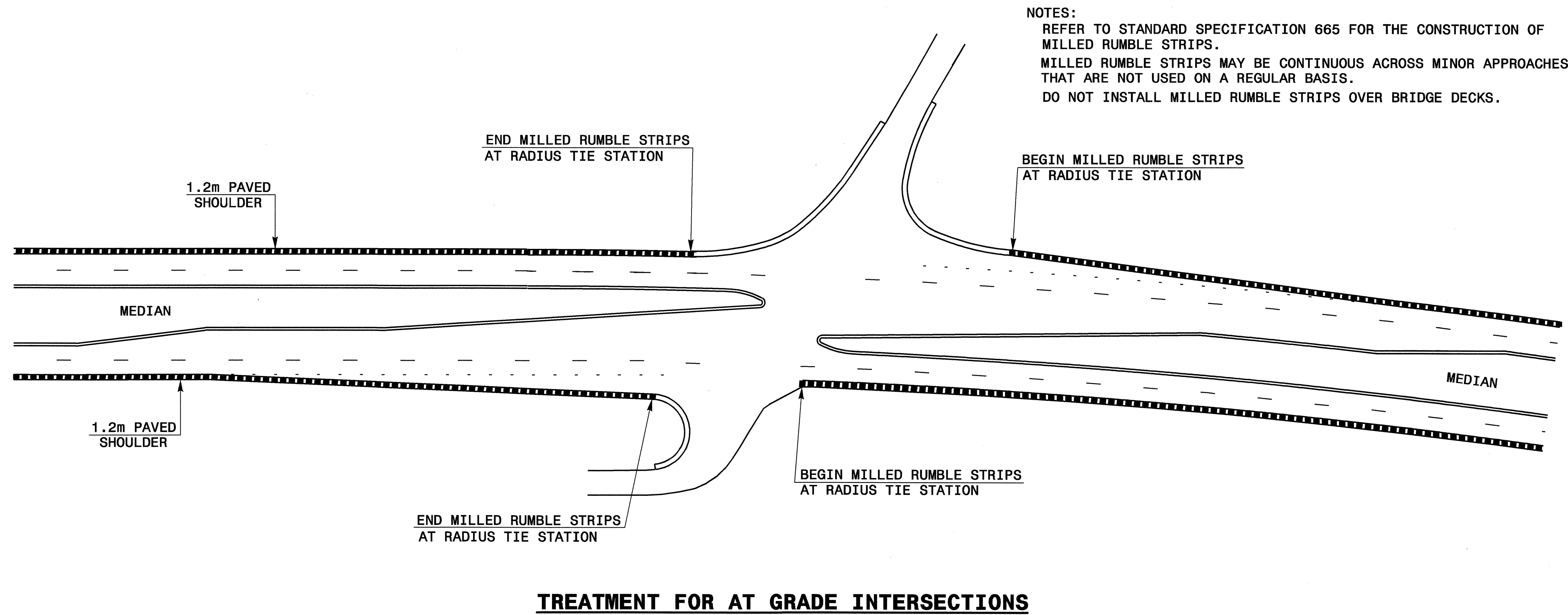

NOTES:
REFER TO STANDARD SPECIFICATION 665 FOR THE CONSTRUCTION OF MILLED RUMBLE STRIPS.
MILLED RUMBLE STRIPS MAY BE CONTINUOUS ACROSS MINOR APPROACHES THAT ARE NOT USED ON A REGULAR BASIS.
DO NOT INSTALL MILLED RUMBLE STRIPS OVER BRIDGE DECKS.

TREATMENT FOR AT GRADE INTERSECTIONS

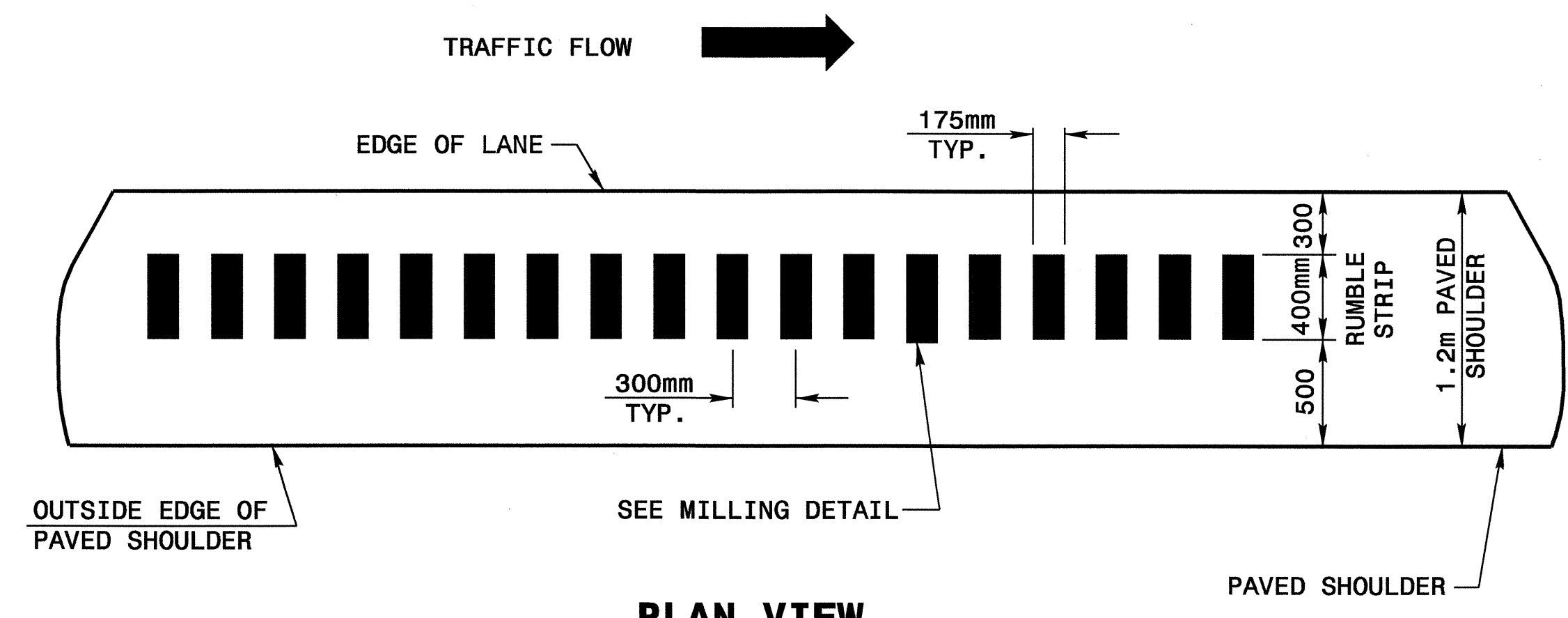

PLAN VIEW

1.2m OUTSIDE PAVED SHOULDER

Note:
This drawing is dimensioned in millimeters unless otherwise depicted within the drawing.

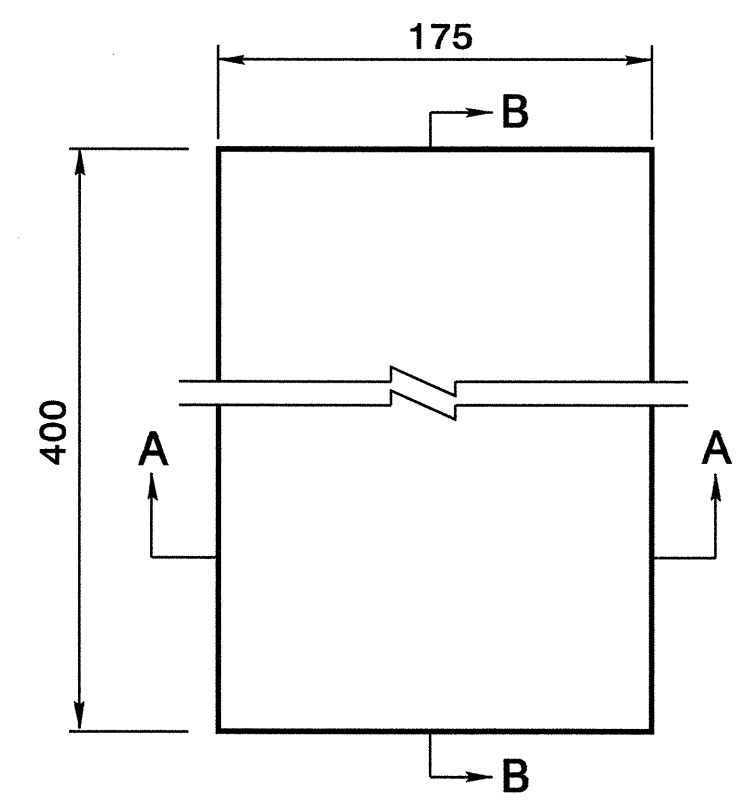

**MILLING DETAIL
PLAN VIEW**

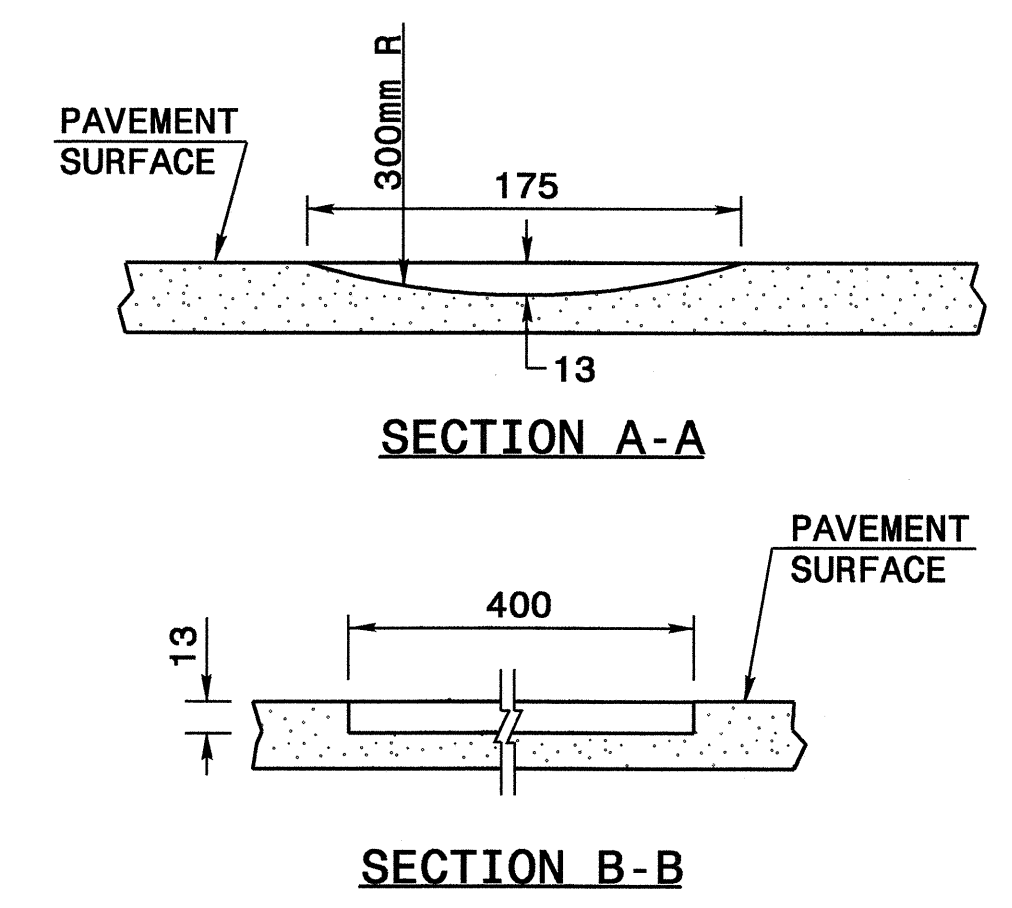

SECTION A-A

SECTION B-B

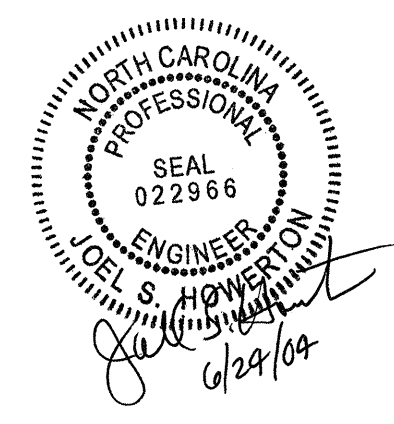

DESIGN SERVICES UNIT
STANDARDS AND SPECIAL DESIGN
Office 919-250-4128 FAX 919-250-4119

SEE PLATE FOR TITLE

ORIGINAL BY: 2002 STANDARDS DATE: 01-15-02
MODIFIED BY: E.E. WARD DATE: 09-08-03
CHECKED BY: [Signature] DATE: 9-03
FILE SPEC.: usr/details/stand/metric/rumble.dgn

08-SEP-2003 10:48
W:\Special Details\ericward\usr\details\stand\metric\stand\rumble.dgn
ericward AT DS212260