

---NOTES---

LONGITUDINAL STEEL MAY BE SHIFTED SLIGHTLY, AS NECESSARY, TO AVOID INTERFERENCE WITH STIRRUPS IN PRESTRESSED CONCRETE GIRDERS.

PREVIOUSLY CAST CONCRETE IN A CONTINUOUS UNIT SHALL HAVE ATTAINED A MINIMUM COMPRESSIVE STRENGTH OF 20.7 MPa BEFORE ADDITIONAL CONCRETE IS CAST IN THE UNIT.

BARRIER RAIL IN A CONTINUOUS UNIT SHALL NOT BE CAST UNTIL ALL SLAB CONCRETE IN THE UNIT HAS BEEN CAST AND HAS REACHED A MINIMUM COMPRESSIVE STRENGTH OF 20.7 MPa.

TEMPORARY STRUTS SHALL BE PLACED BETWEEN PRESTRESSED GIRDERS ADJACENT TO THE DIAPHRAGMS AND THE NUTS ON THE 31.75mm DIA. TIE RODS SHALL BE FULLY TIGHTENED BEFORE THE DIAPHRAGMS ARE CAST. STRUTS SHALL REMAIN IN PLACE 3 DAYS AFTER CONCRETE IS PLACED. THE TIE RODS SHALL BE RE-TIGHTENED AFTER THE STRUTS HAVE BEEN REMOVED.

\* USE THIS SIZE BAR SUPPORT IN THE AREAS WITH #13"B" BARS, FOR OTHER AREAS WITH #22"B" BARS, USE THE BAR SUPPORT AS SHOWN IN TYPICAL SECTION AT BENT.

PROVIDE 32mm HIGH BEAM BOLSTERS AT 1.2m CTS. ATOP THE METAL STAY-IN-PLACE FORMS TO SUPPORT THE BOTTOM MAT OF 'A' BARS. WHEN USING REMOVABLE FORMS, PROVIDE CONTINUOUS HIGH CHAIRS FOR METAL DECK (C.H.C.M.) @ 1.2m CTS. WITH A HEIGHT TO SUPPORT THE BOTTOM MAT OF 'A' BARS AT A CLEAR DISTANCE OF 65mm ABOVE THE TOP OF THE REMOVABLE FORM.

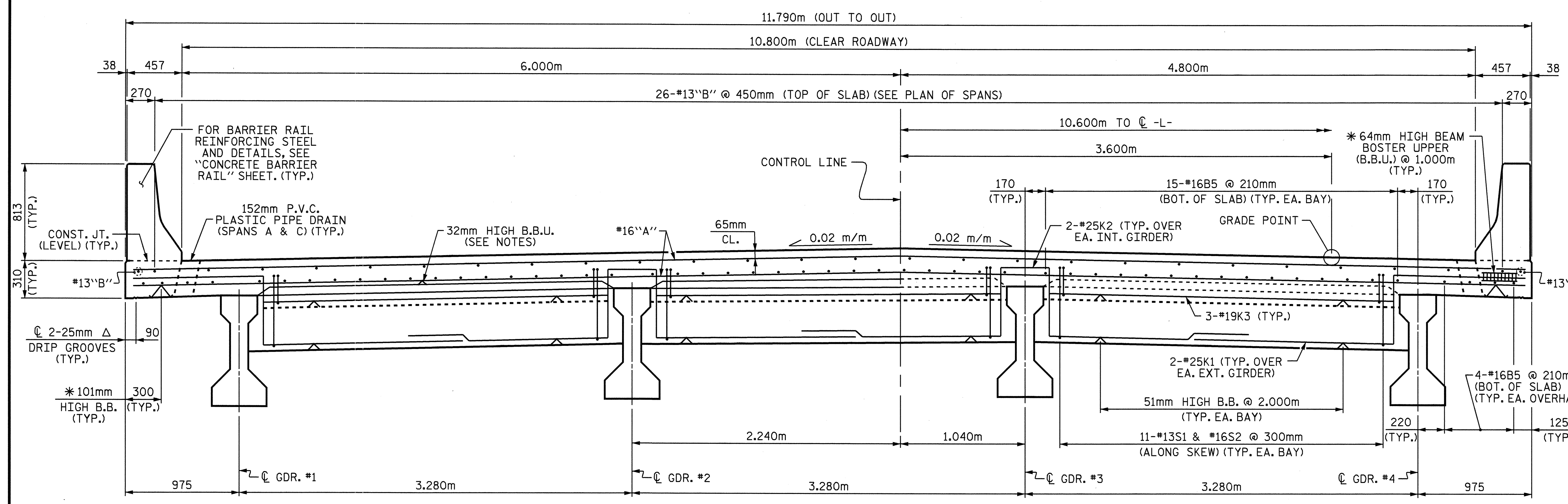

TYPICAL SECTION AT END BENT DIAPHRAGM

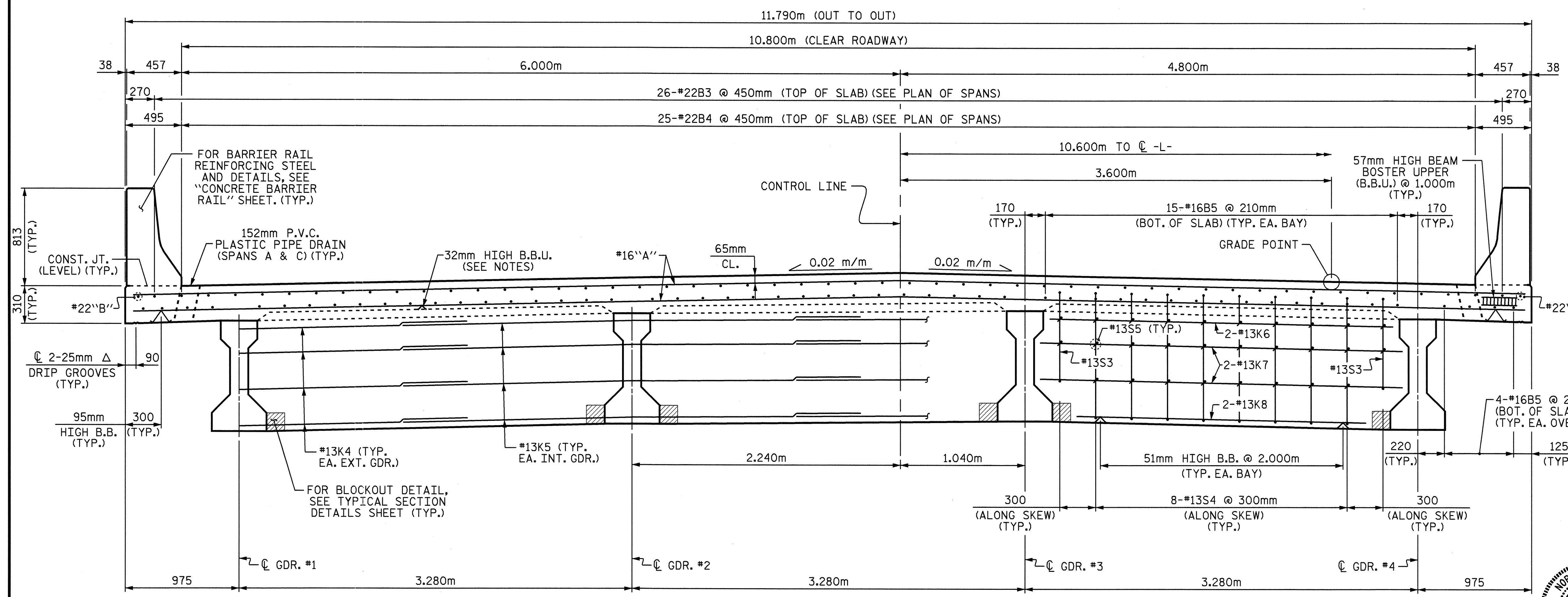
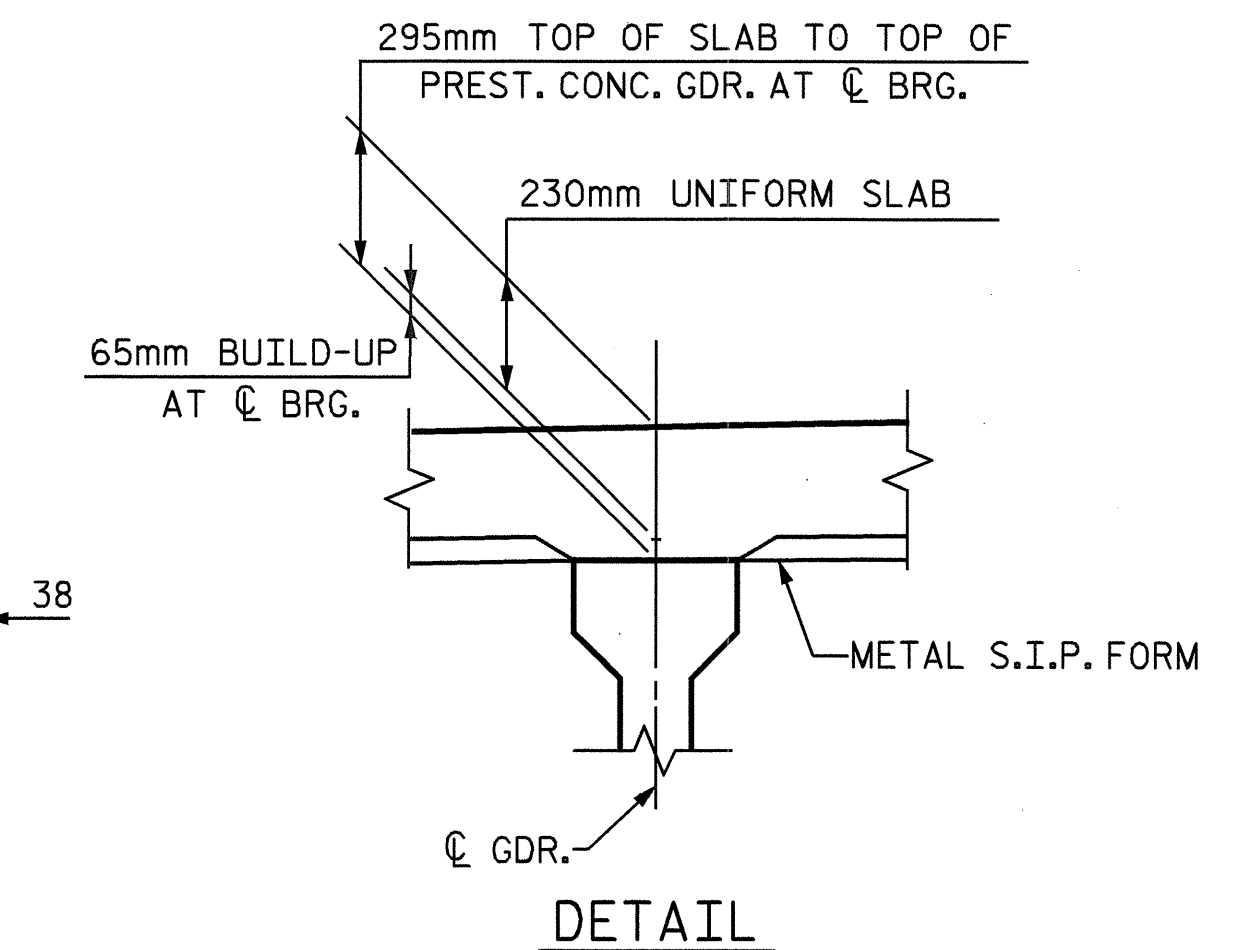

TYPICAL SECTION AT BENT DIAPHRAGM

PROJECT NO. R-2610B  
CHATHAM COUNTY  
STATION: 97+00.000-L-  
SHEET 1 OF 2

STATE OF NORTH CAROLINA  
DEPARTMENT OF TRANSPORTATION  
RALEIGH

SUPERSTRUCTURE  
TYPICAL SECTION

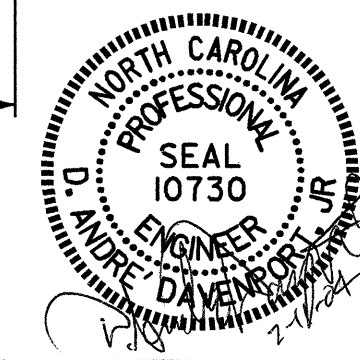

DRAWN BY: B.N. GRADY DATE: 2/03  
CHECKED BY: H.T. BARBOUR DATE: 9/03

REVISIONS						SHEET NO.	
NO.	BY:	DATE:	NO.	BY:	DATE:	S-34	
1			3			TOTAL SHEETS	60
2			4				