

CULVERT SECTION NORMAL TO ROADWAY

**BILL OF MATERIAL  
RIGHT EXTENSION**

BAR	NO.	SIZE	TYPE	LENGTH	WEIGHT
A100	28	19	STR	2080	130
A200	28	19	STR	2080	130
A1	50	16	6	1980	154
A2	50	16	6	2020	157
B1	42	13	STR	2200	92
C1	38	13	STR	5100	193
D1	18	19	STR	760	31
G1	2	13	STR	2100	4
F1	4	13	STR	1300	5
REINFORCING STEEL					896

**SPLICE LENGTH CHART**

BAR	SIZE	SPLICE LENGTH
B1	13	540
C1	13	590

**BAR TYPE**

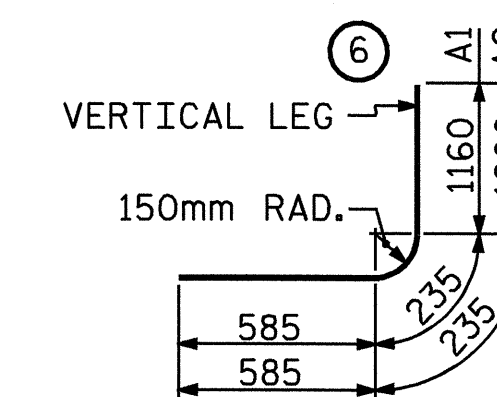

DIMENSIONS ARE OUT TO OUT

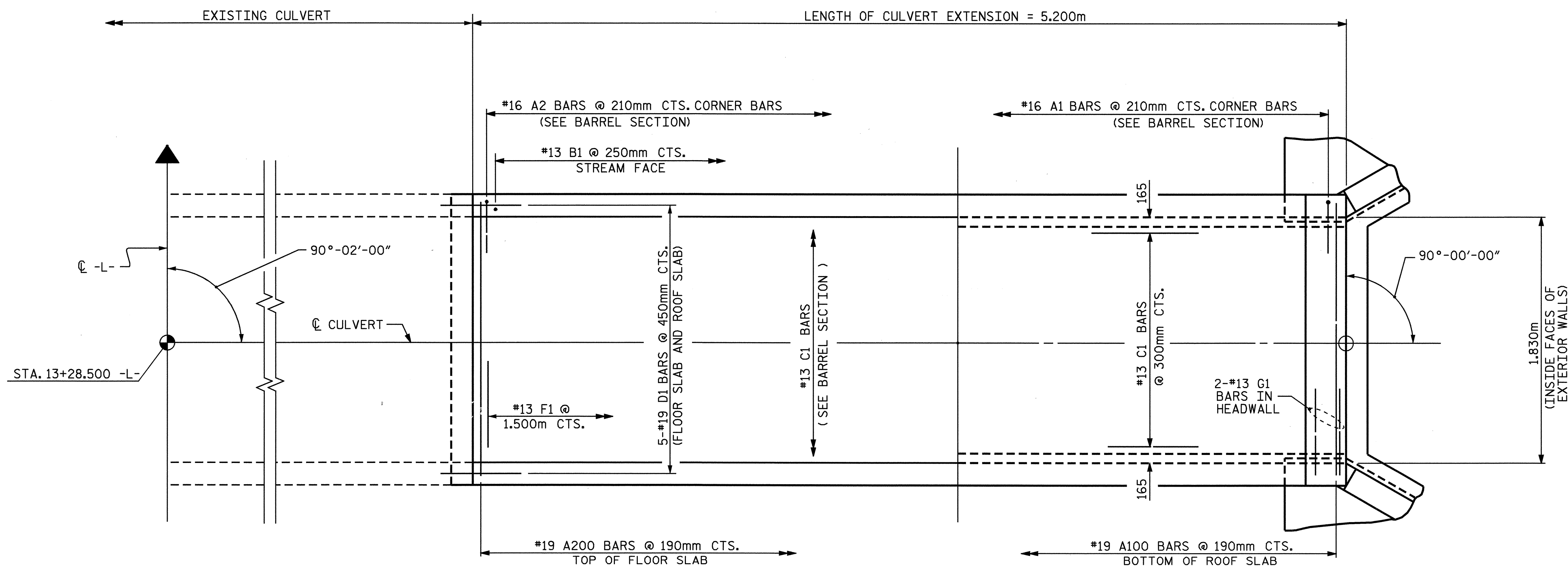

PART PLAN - FLOOR SLAB

PART PLAN - ROOF SLAB

PROJECT NO. R-2610A  
CHATHAM COUNTY  
 STATION: 13+28.500 -L-

SHEET 2 OF 6

STATE OF NORTH CAROLINA  
 DEPARTMENT OF TRANSPORTATION  
 RALEIGH

**SINGLE BARREL  
 1.830m X 1.830m  
 CONCRETE BOX CULVERT  
 RIGHT EXTENSION**



DRAWN BY : J. LAMBERT DATE : 9/03  
 CHECKED BY : S. PEARCE DATE : 11/03

REVISIONS					SHEET NO.
NO.	BY:	DATE:	NO.	BY:	DATE:
1			3		
2			4		

TOTAL SHEETS  
18