

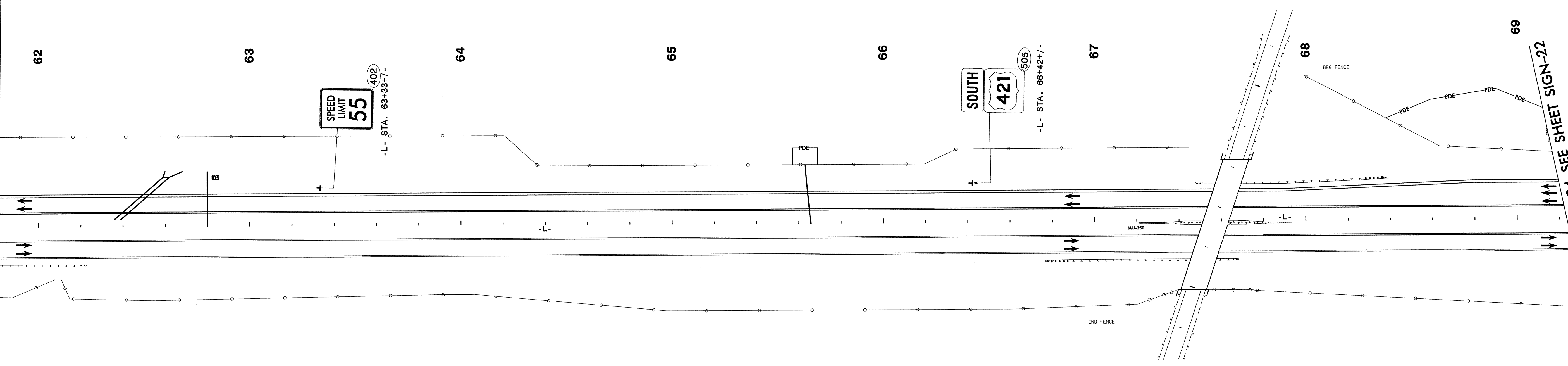

MATCHLINE -L- STA. 61+80 SEE SHEET SIGN-20

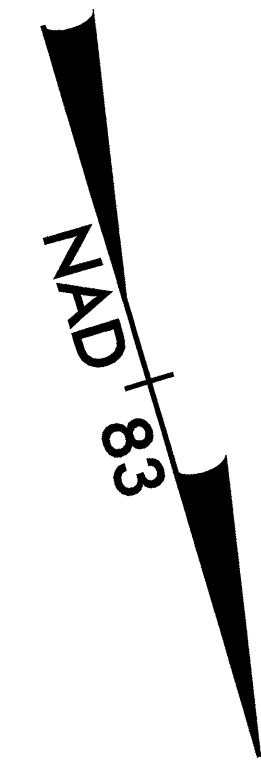

MATCHLINE -L- STA. 69+24 SEE SHEET SIGN-22



SEPI ENGINEERING GROUP
 2300 Rexwoods Drive
 Suite 370
 Raleigh, NC 27607
 Tel: 919-789-9377 Fax: 789-9591

APPROVED: _____ DATE: _____

 10.10.03

US 421 PROPOSED SIGNS STA. 61+80 +/- TO STA. 69+24 +/-				
SCALE: NONE	N. C. DEPARTMENT OF TRANSPORTATION DIVISION OF HIGHWAYS TRAFFIC ENGINEERING BRANCH	REVISIONS		
DATE: 10/03				
DWG. BY: RCD				
DESIGN BY: RCD				
REVIEWED BY: SSA		<table border="1"> <tr> <td>CRD</td> <td>PRE</td> </tr> </table>	CRD	PRE
CRD	PRE			