

20-MAY-2003 07:54  
 C:\pwork\stds\02\Stds to Special Details\metric\86202\0862d02.mxd  
 rspec1 AT 05198510

STATE OF  
 NORTH CAROLINA  
 DEPT. OF TRANSPORTATION  
 DIVISION OF HIGHWAYS  
 RALEIGH, N.C.

METRIC DETAIL DRAWING FOR  
 GUARDRAIL INSTALLATION

SHEET 5 OF 7  
**862D02**

STATE OF  
 NORTH CAROLINA  
 DEPT. OF TRANSPORTATION  
 DIVISION OF HIGHWAYS  
 RALEIGH, N.C.

METRIC DETAIL DRAWING FOR  
 GUARDRAIL INSTALLATION

SHEET 5 OF 7  
**862D02**

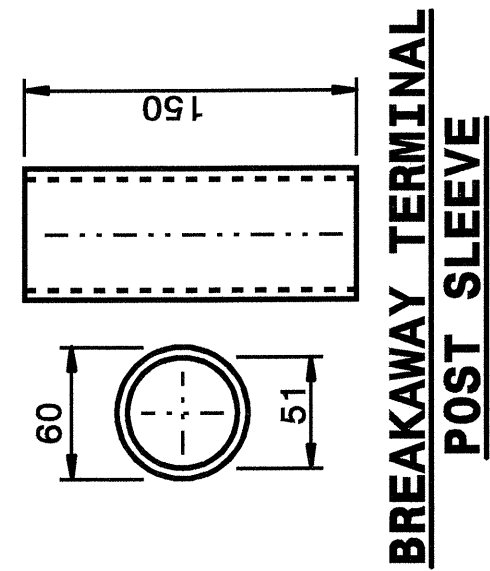

**BREAKAWAY TERMINAL  
 POST SLEEVE**

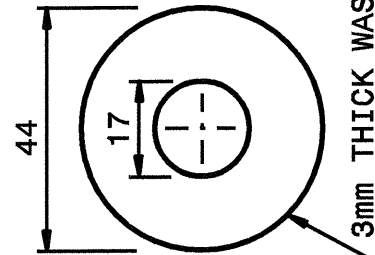

**3mm THICK WASHER**

**DETAIL OF STANDARD WASHER**

STANDARD WASHER: TYPICAL USE UNDER NUT WITH WOOD POST

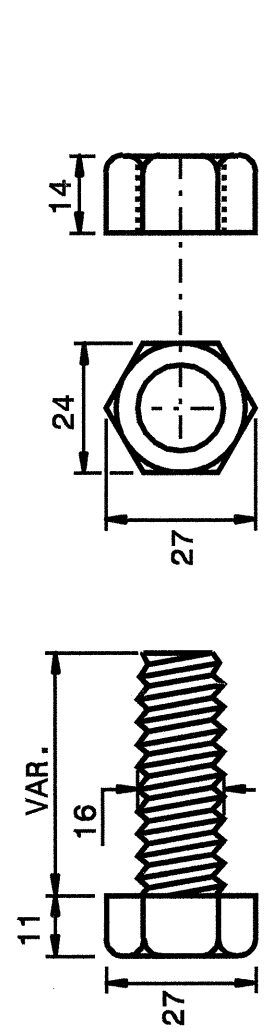

**DETAIL OF STANDARD HEX BOLT AND NUT**

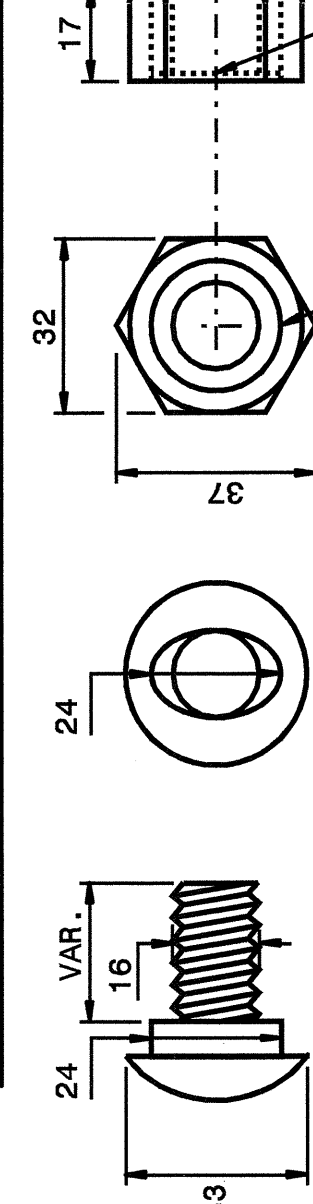

**DETAIL OF BUTTON HEAD BOLT AND NUT**

Note:  
 This drawing is dimensioned in  
 millimeters unless otherwise  
 depicted within the drawing.

**SYSTEM PARTS**

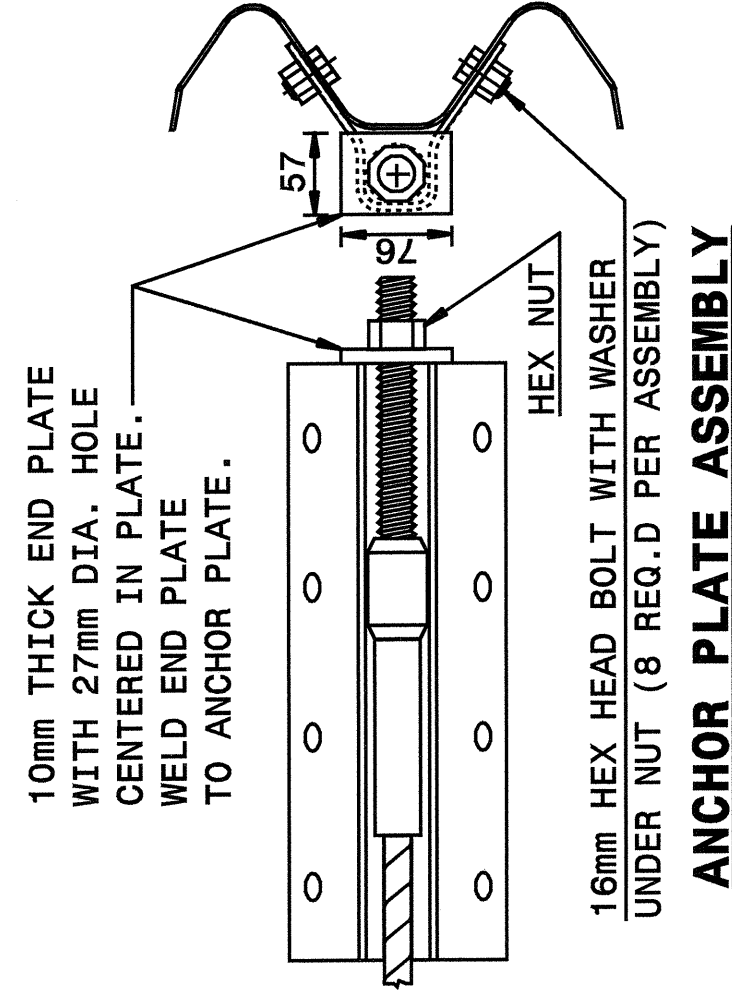

**ANCHOR PLATE ASSEMBLY**

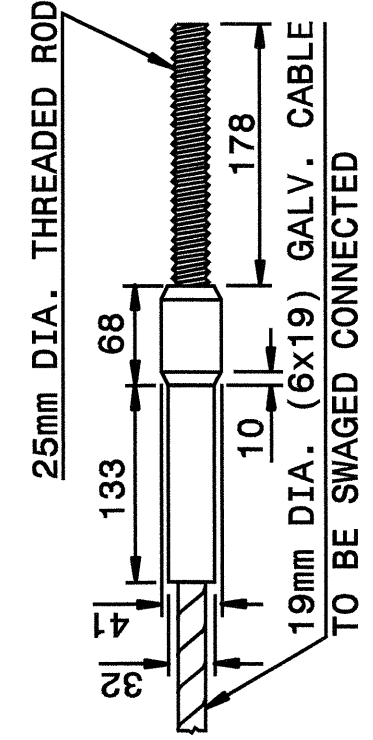

**SWAGED CABLE**

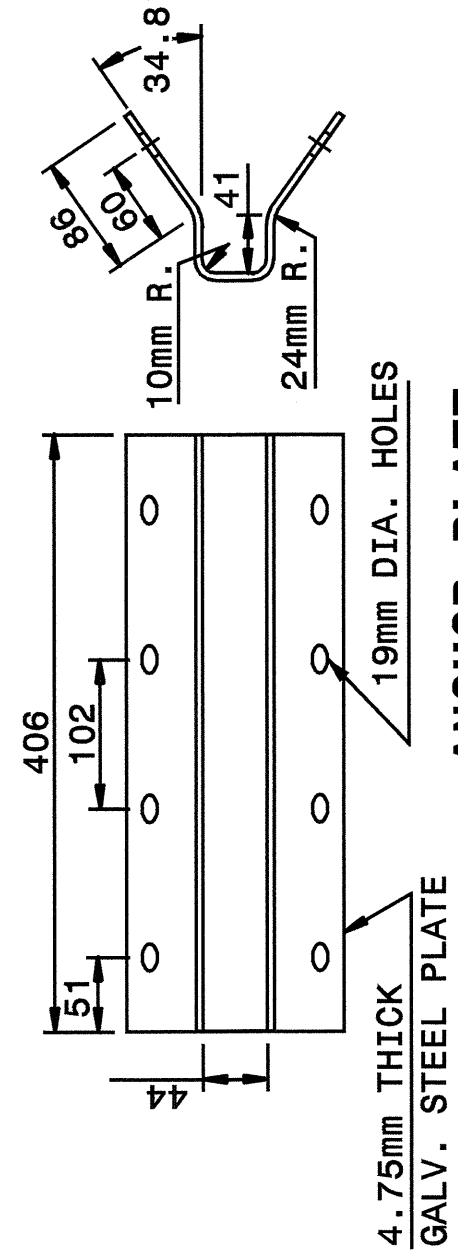

**CABLE ASSEMBLY**

SHEET 5 OF 7  
**862D02**

STATE OF  
 NORTH CAROLINA  
 DEPT. OF TRANSPORTATION  
 DIVISION OF HIGHWAYS  
 RALEIGH, N.C.

METRIC DETAIL DRAWING FOR  
 GUARDRAIL INSTALLATION

SHEET 6 OF 7  
**862D02**

STATE OF  
 NORTH CAROLINA  
 DEPT. OF TRANSPORTATION  
 DIVISION OF HIGHWAYS  
 RALEIGH, N.C.

METRIC DETAIL DRAWING FOR  
 GUARDRAIL INSTALLATION

SHEET 6 OF 7  
**862D02**

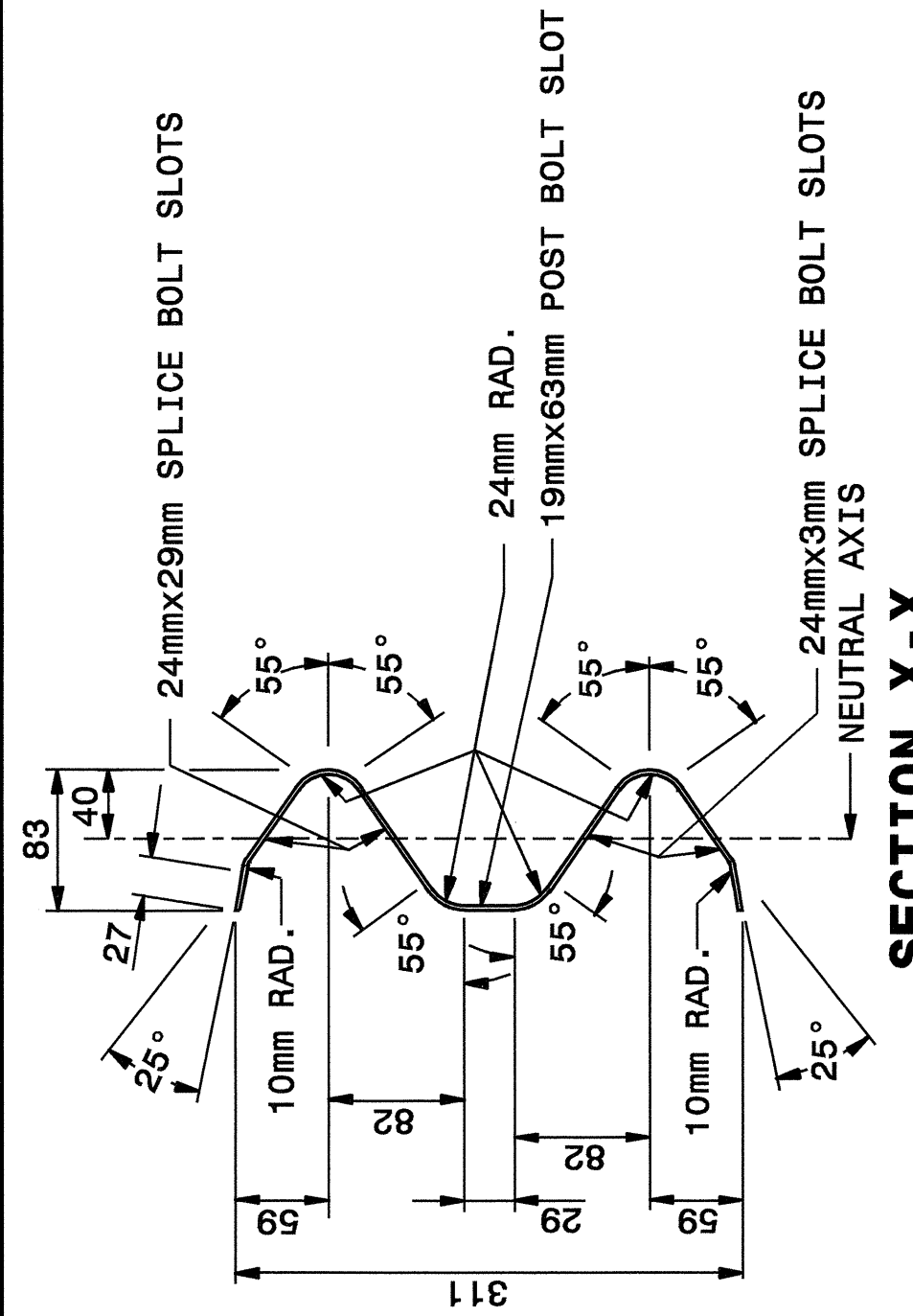

**SECTION X-X**

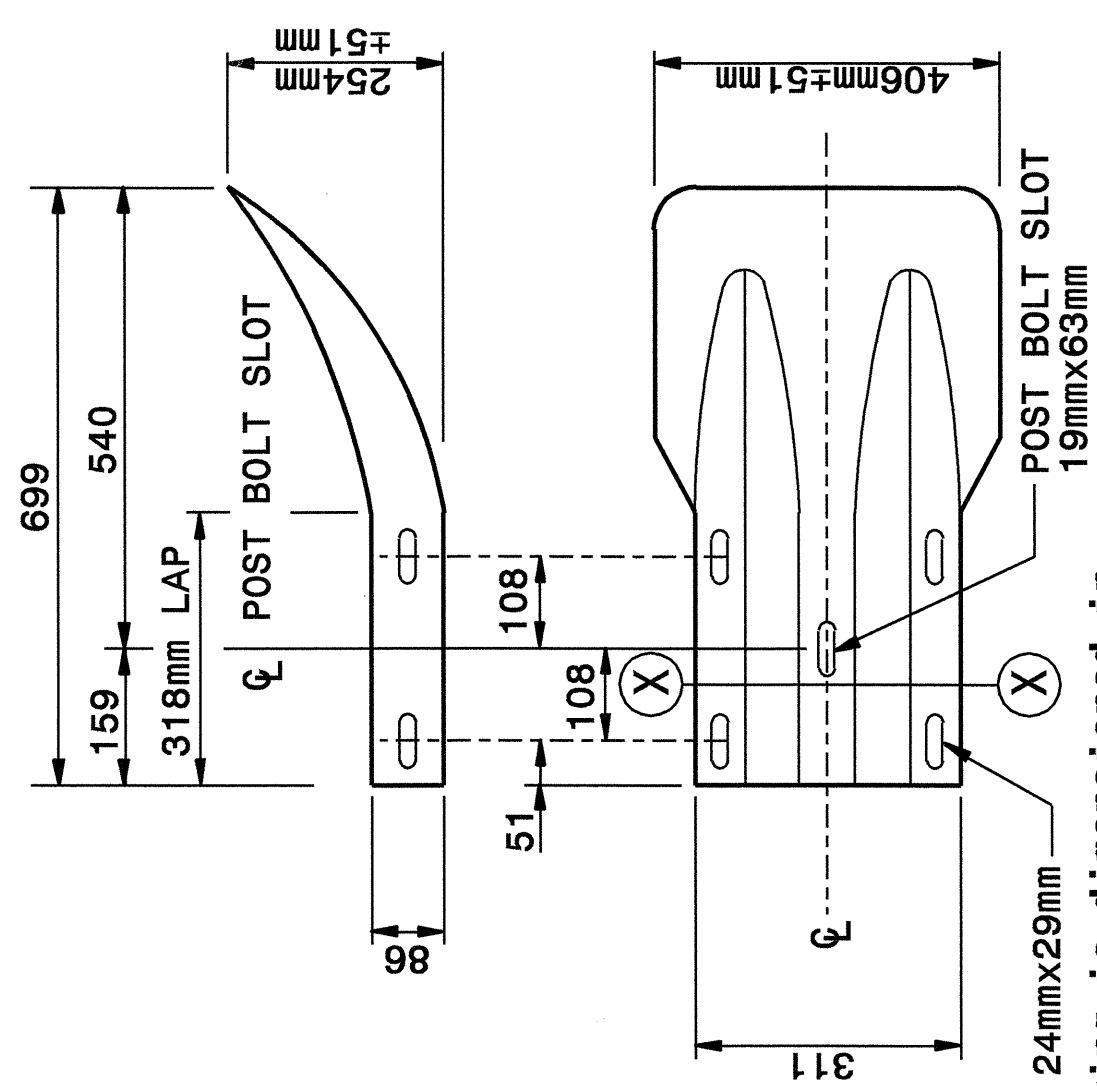

**TERMINAL END SECTION**

Note:  
 This drawing is dimensioned in  
 millimeters unless otherwise  
 depicted within the drawing.

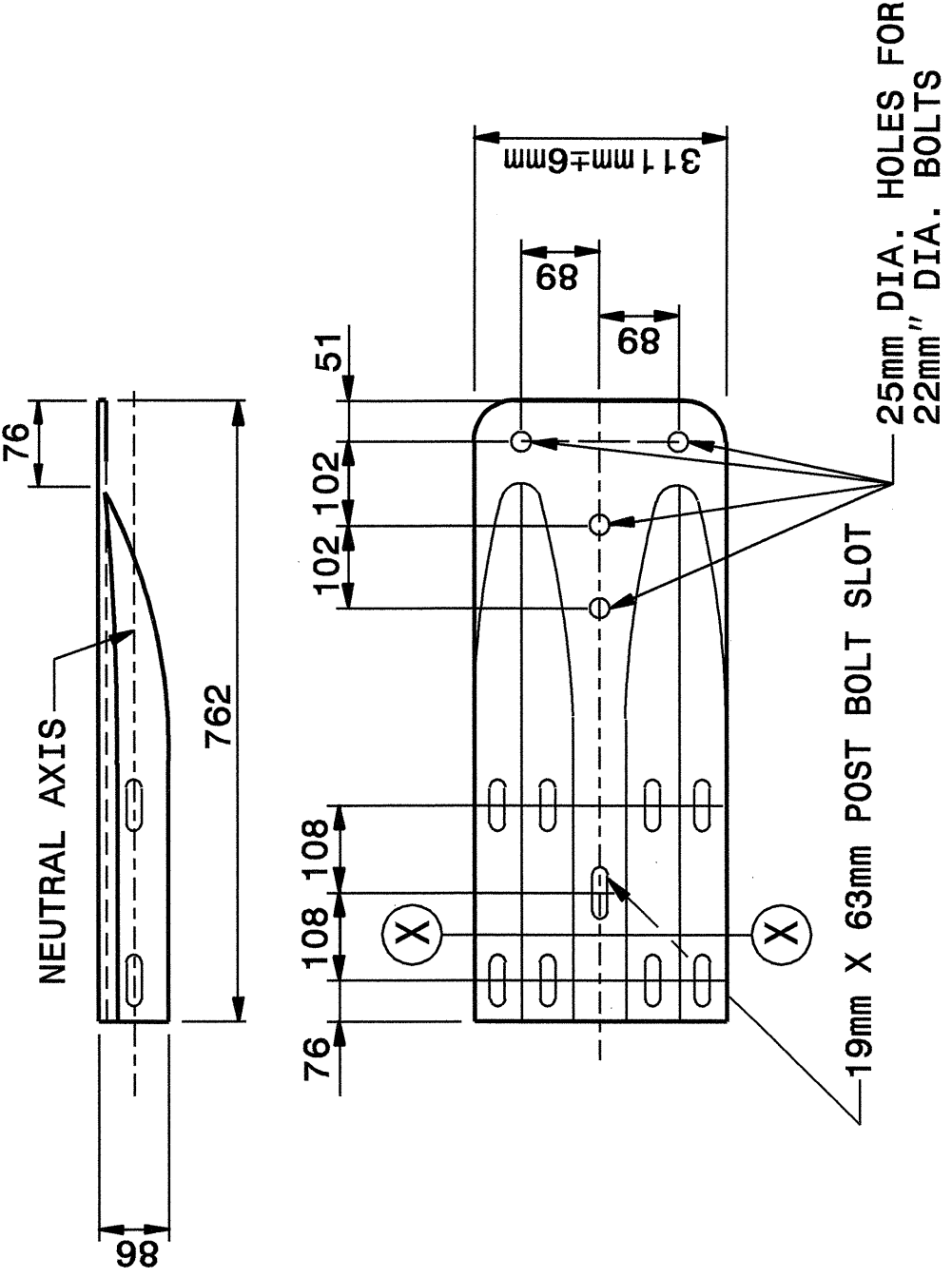

**TYPICAL END SHOE**

**SYSTEM PARTS - GENERAL USE**

DESIGN SERVICES UNIT  
 STANDARDS AND SPECIAL DESIGN  
 Office 919-250-4128 FAX 919-250-4119

**SEE PLATE FOR TITLE**

ORIGINAL BY: 2002 STD.862.02 DATE:  
 MODIFIED BY: E.E. WARD DATE: 02-09-03  
 CHECKED BY: DATE: 5-05  
 FILE SPEC.: /usr/stds/02todet4/metric/86202/862d02m.dgn

