

HALF SECTION AT INTERMEDIATE DIAPHRAGM HALF SECTION AT 12" Ø VOIDS

TYPICAL SECTION

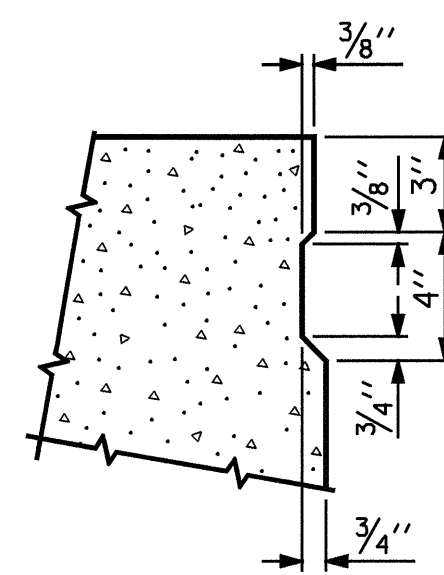

SHEAR KEY DETAIL

NOTE: OMIT SHEAR KEY ON OUTSIDE FACE OF EXTERIOR CORED SLABS.

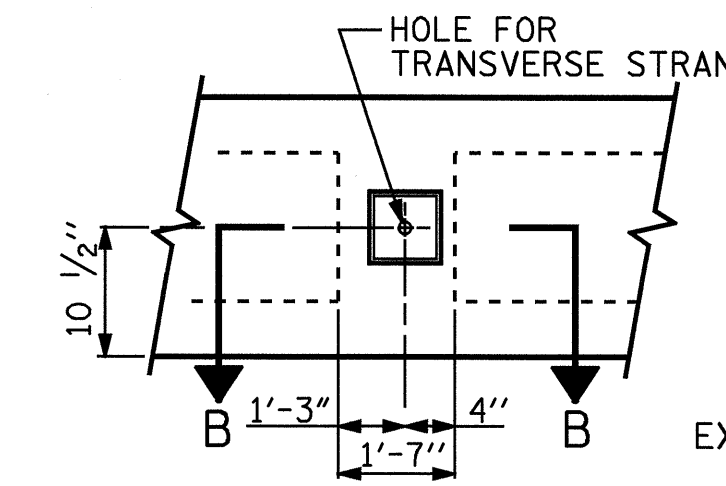

ELEVATION VIEW

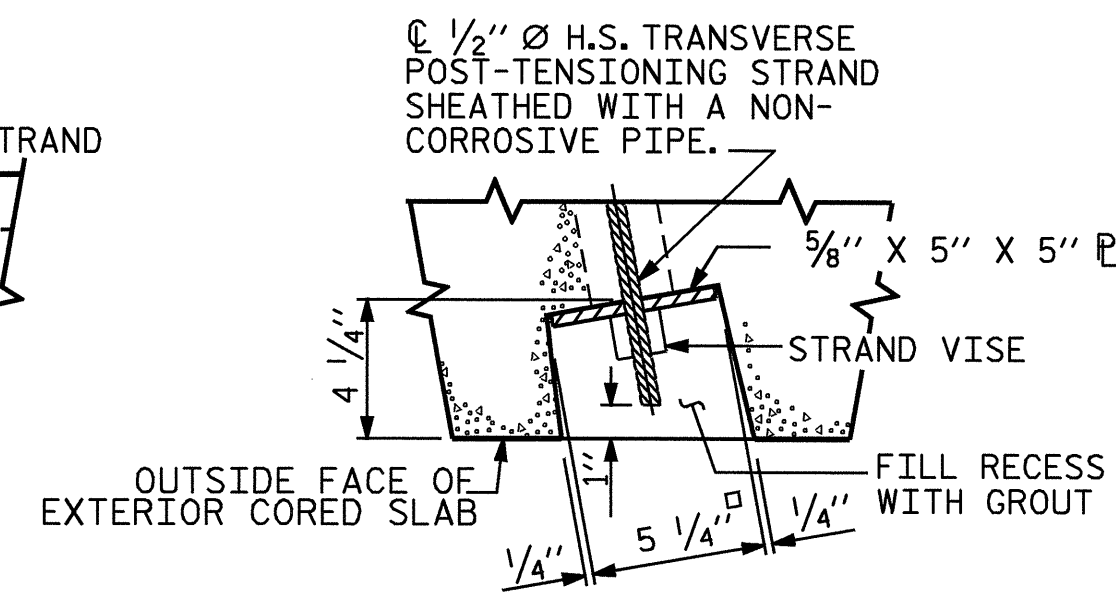

SECTION B-B

GROUTED RECESS AT END OF POST-TENSIONED STRAND CORED SLABS

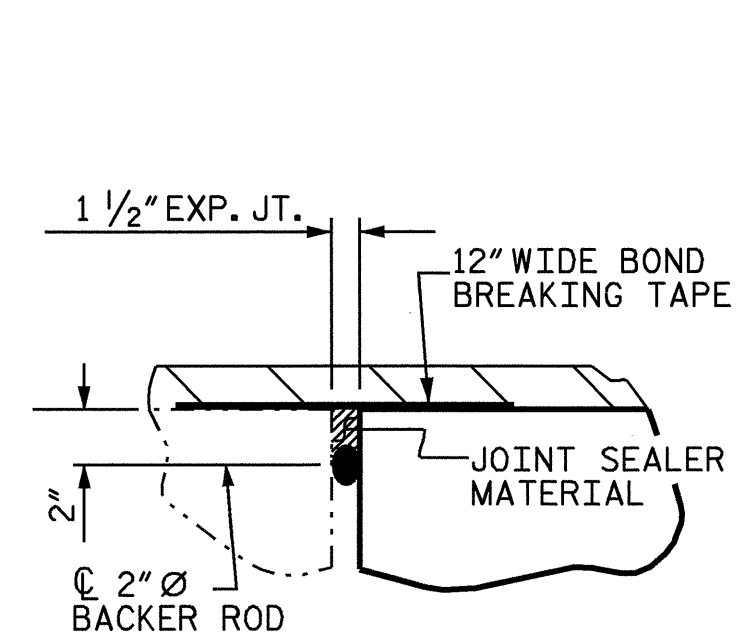

DETAIL A

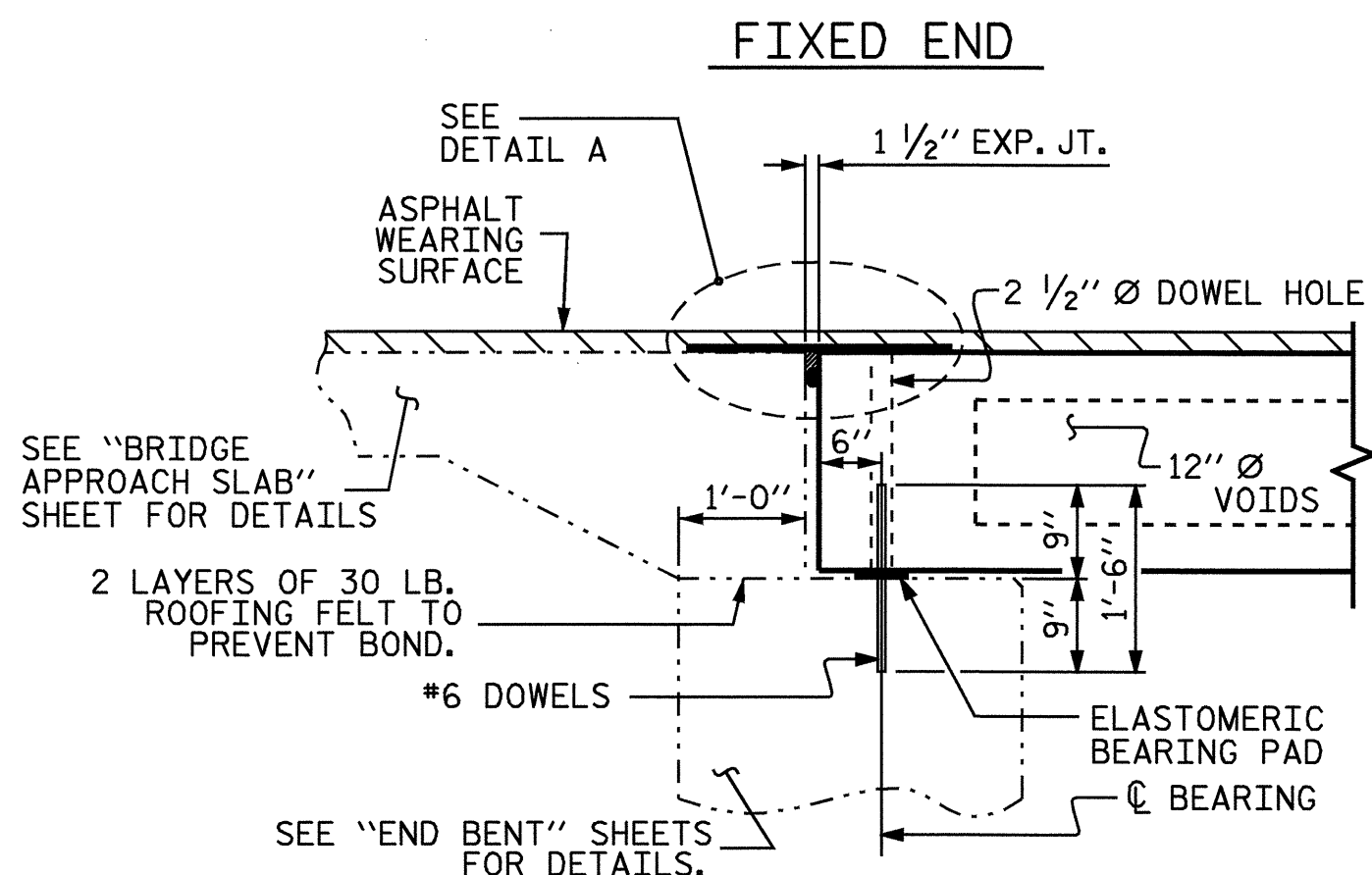

SECTION AT END BENT

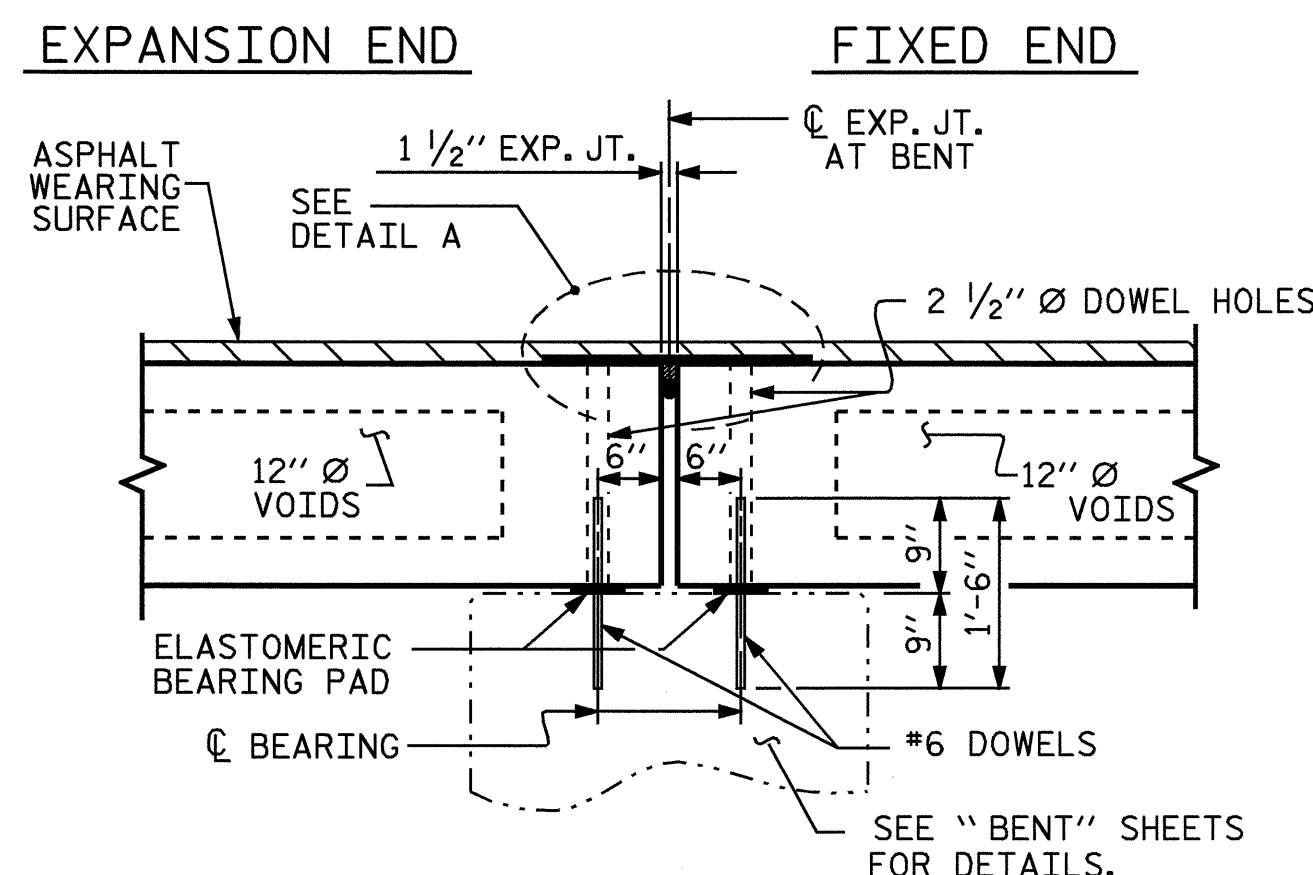

SECTION AT BENTS

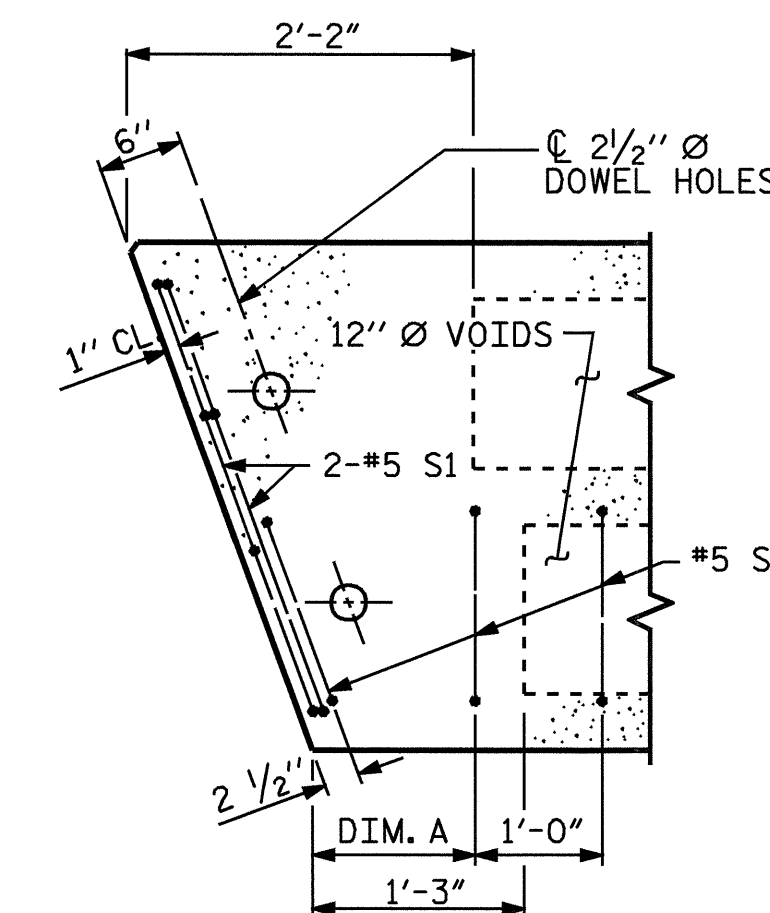

PART PLAN-EXTERIOR SECTION

NOTE: EXTERIOR SECTION SHOWN-INTERIOR SECTION SIMILAR EXCEPT OMIT S3 BARS. SEE PLAN OF SPAN FOR DIM. A

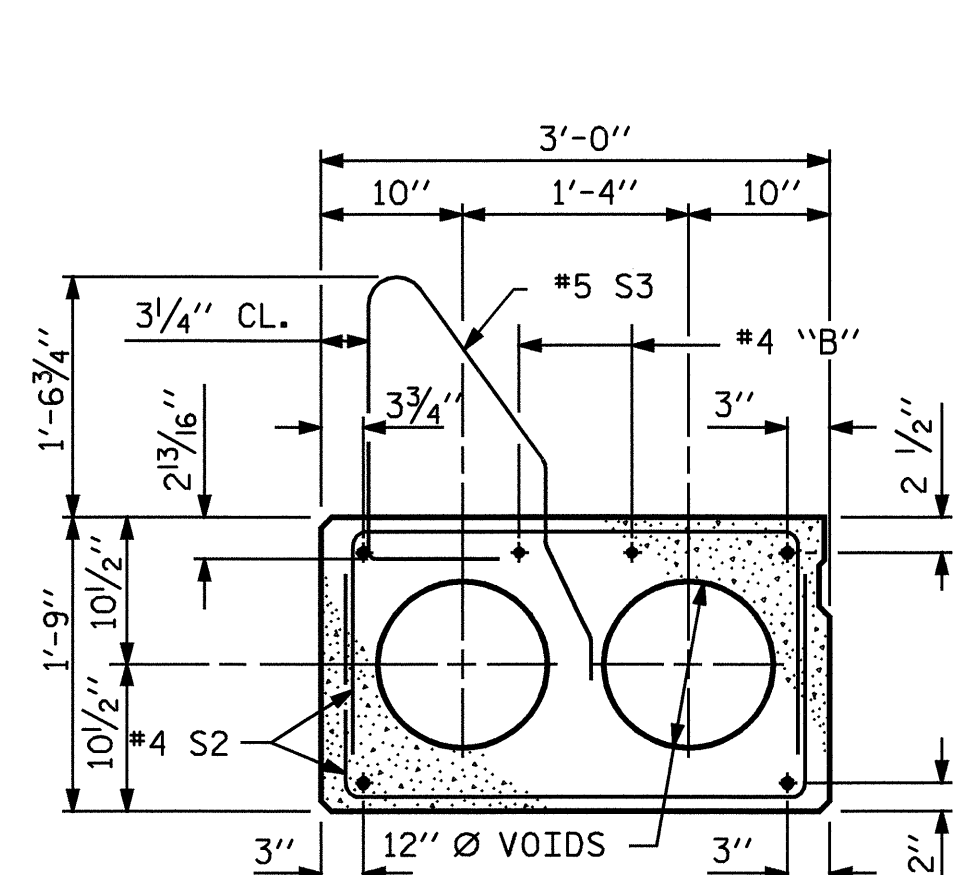

EXTERIOR SLAB SECTION

(FOR PRESTRESSED STRAND LAYOUT, SEE INTERIOR SLAB SECTION.)

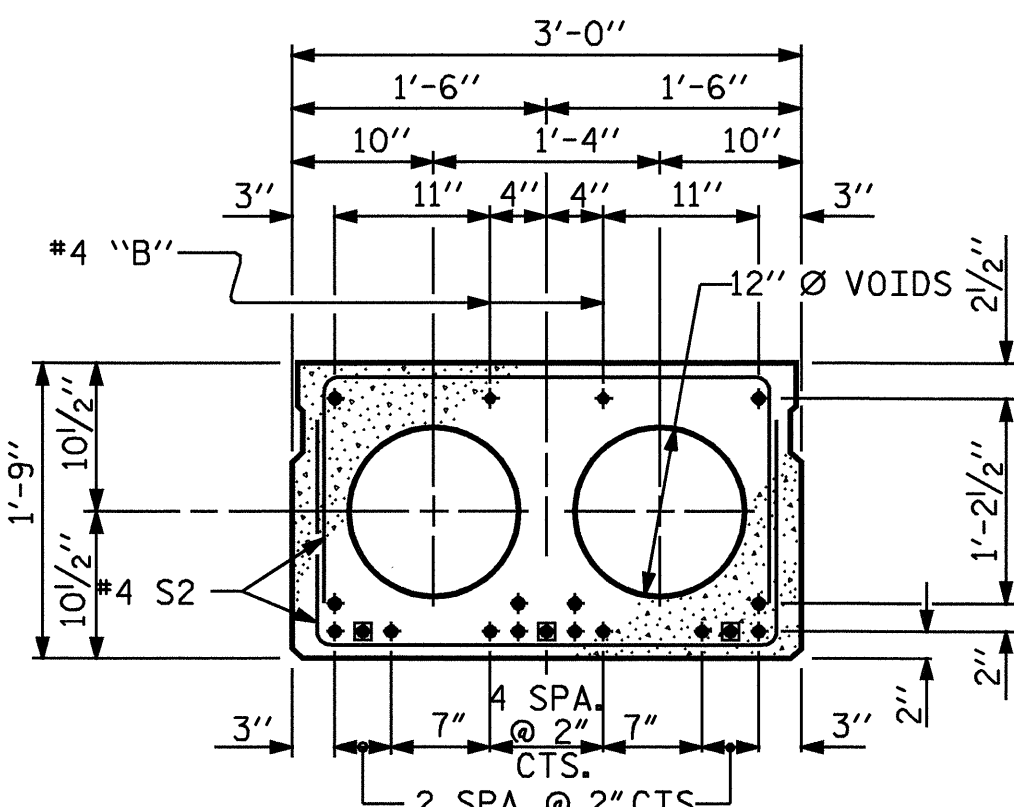

**INTERIOR SLAB SECTION
1/2" Ø LOW RELAXATION STRAND LAYOUT**

ⓈBOND SHALL BE BROKEN ON THESE STRANDS FOR A DISTANCE OF 4'-0" FROM END OF CORED SLAB UNIT. SEE STANDARD SPECIFICATIONS ARTICLE 1078-7.

**SPANS A & C
(17 STRANDS)**

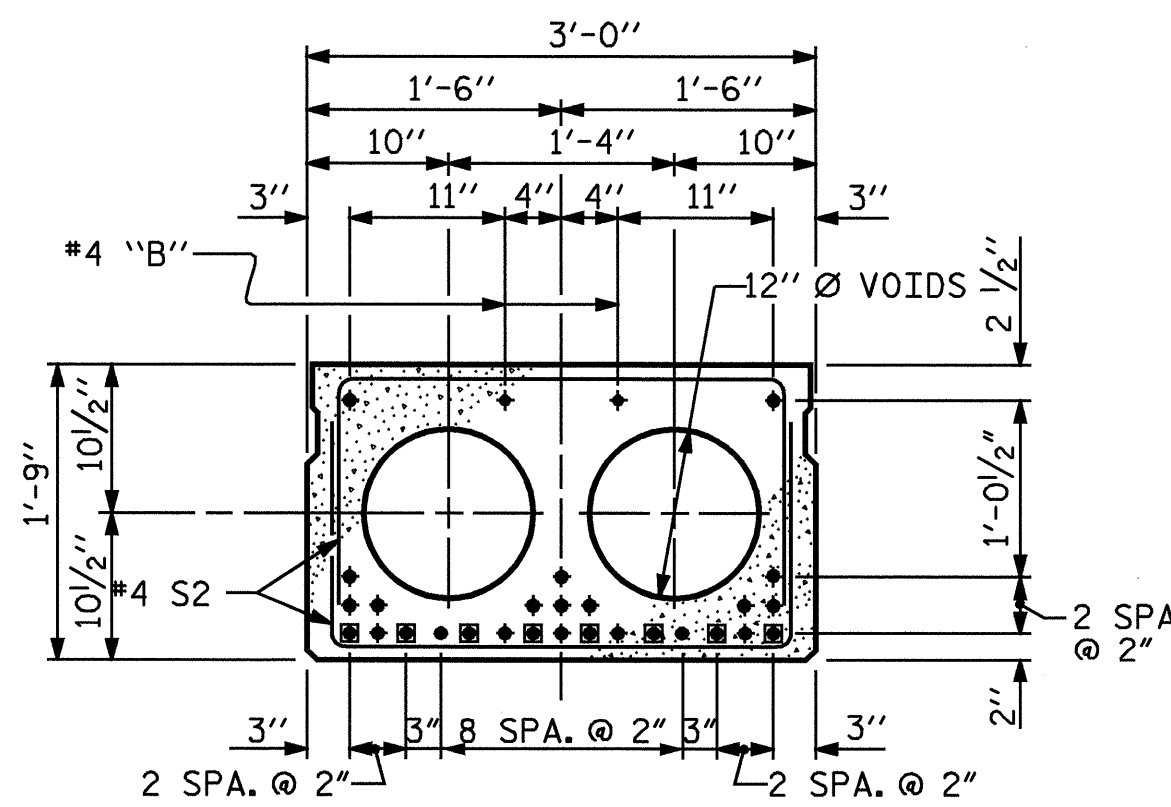

**INTERIOR SLAB SECTION
1/2" Ø LOW RELAXATION STRAND LAYOUT**

ⓈBOND SHALL BE BROKEN ON THESE STRANDS FOR A DISTANCE OF 5'-6" FROM END OF CORED SLAB UNIT. SEE STANDARD SPECIFICATIONS ARTICLE 1078-7.

**SPAN B
(27 STRANDS)**

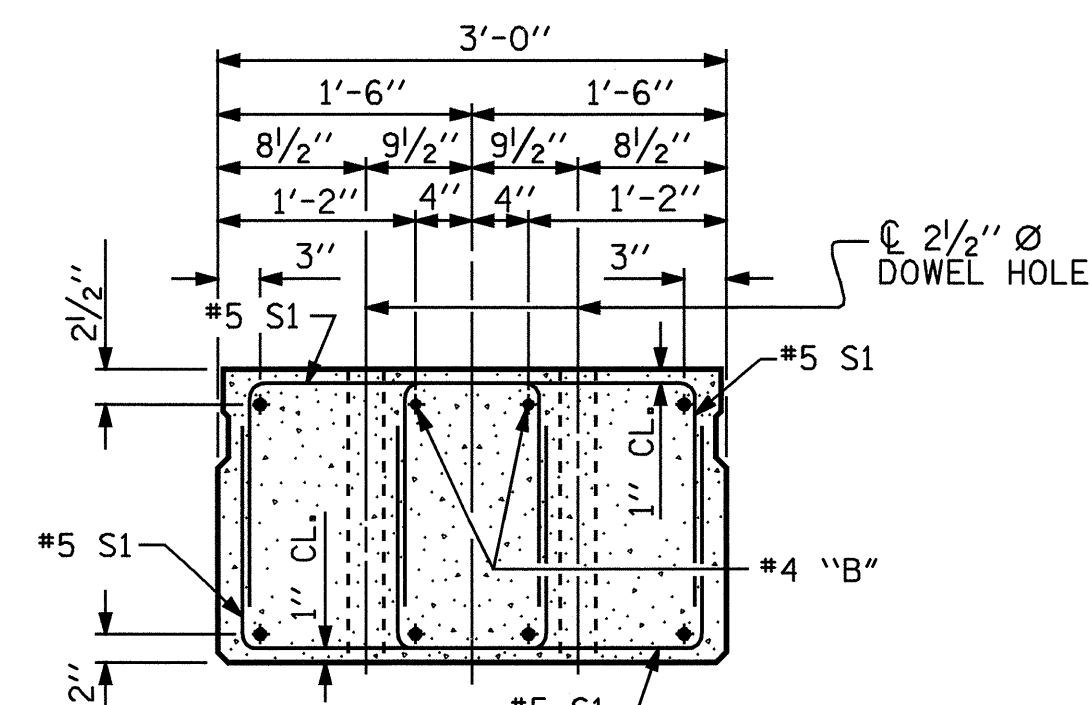

END ELEVATION

SHOWING PLACEMENT OF DOUBLE STIRRUPS AND SECTION SIMILAR EXCEPT SHEAR KEY LOCATION. (STRAND LAYOUT NOT SHOWN.) INTERIOR SLAB SECTION SHOWN-EXTERIOR SLAB LOCATION OF DOWEL HOLES.



PROJECT NO. B-3901
ROCKINGHAM COUNTY
 STATION: 23+37.40 -L-

SHEET 1 OF 5

STATE OF NORTH CAROLINA
 DEPARTMENT OF TRANSPORTATION
 RALEIGH
**STANDARD
 3'-0" X 1'-9"
 PRESTRESSED CONCRETE
 CORED SLAB UNIT**

REVISIONS				SHEET NO.	
NO.	BY:	DATE:	NO.	BY:	DATE:
1			3		
2			4		
					S-4
					TOTAL SHEETS 22

DRAWN BY: R. G. EMERSON DATE: 02/04
 CHECKED BY: A. V. ROYAL DATE: 02/04

21-JUL-2004 08:11
 W:\squadw\b3901\emerson\lmcrostation\B3901.sd_CS_01.dgn
 dpetry