

EDI MODEL 2010ECL CONFLICT MONITOR

PROGRAMMING DETAIL

(remove jumpers and set switches as shown)

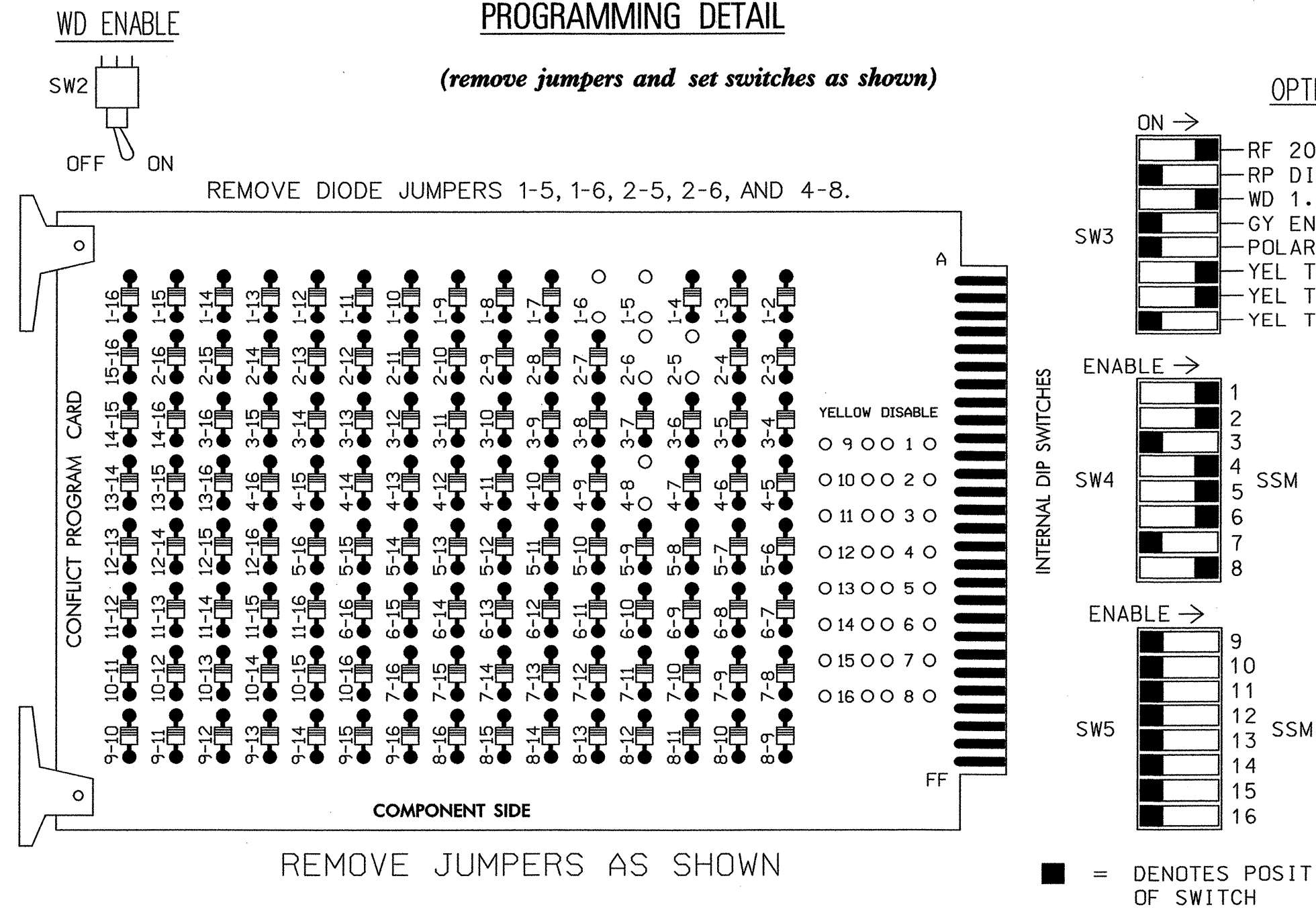

NOTES:

- CARD IS PROVIDED WITH ALL DIODE JUMPERS IN PLACE. REMOVAL OF ANY JUMPER ALLOWS ITS CHANNELS TO RUN CONCURRENTLY.
- MAKE SURE JUMPERS SEL1-SEL5 ARE PRESENT ON THE MONITOR BOARD.

NOTES

- TO PREVENT "FLASH-CONFLICT" PROBLEMS, INSERT RED FLASH PROGRAM BLOCKS FOR ALL UNUSED VEHICLE LOAD SWITCHES IN THE OUTPUT FILE. THE INSTALLER SHALL VERIFY THAT SIGNAL HEADS FLASH IN ACCORDANCE WITH THE SIGNAL PLANS.
- ENSURE THAT RED ENABLE IS ACTIVE AT ALL TIMES DURING NORMAL OPERATION. TO PREVENT RED FAILURES ON UNUSED MONITOR CHANNELS, TIE UNUSED RED MONITOR INPUTS 3,7,9,10,11,12,13,14,15 & 16 TO LOAD SWITCH AC+ PER CABINET MANUFACTURER'S INSTRUCTIONS.
- PROGRAM CONTROLLER TO START UP IN PHASES 2 AND 6 GREEN.
- ENABLE SIMULTANEOUS GAP-OUT FEATURE, ON CONTROLLER UNIT, FOR ALL PHASES.
- PROGRAM PHASES 4 AND 8, ON CONTROLLER UNIT, FOR DUAL ENTRY.
- PROGRAM PHASES 2 AND 6, ON CONTROLLER UNIT, FOR VARIABLE INITIAL AND GAP REDUCTION.
- THE ACCUTIME 2000 GPS IS PREEXISTING AND THE CONNECTOR WIRING DETAIL IS PROVIDED FOR REFERENCE. THE GPS UNIT WILL BE REMOVED WHEN THE CABINET IS REPLACED.

EQUIPMENT INFORMATION

CONTROLLER.....EXISTING 2070L CONTROLLER  
 CABINET .....EXISTING TYPE 332 CABINET  
 SOFTWARE .....ECONOLITE OASIS  
 CABINET MOUNT.....BASE  
 OUTPUT FILE POSITIONS...12  
 LOAD SWITCHES USED.....S1,S2,S4,S5,S6,S8  
 PHASES USED.....1,2,4,5,6,8  
 OVERLAPS.....NONE

FIELD CONNECTION HOOK-UP CHART

LOAD SWITCH NO.	S1	S2	S2P	S3	S4	S4P	S5	S6	S6P	S7	S8	S8P	
PHASE	1	2	2 PED	3	4	4 PED	5	6	6 PED	7	8	8 PED	
SIGNAL HEAD NO.	11	82	21,22	NU	NU	41,42	NU	42	51,52	61,62	NU	81,82	NU
GREEN			130		103				136			109	
YELLOW			129		102				135			108	
RED			128		101				134			107	
RED ARROW	125								131				
YELLOW ARROW	126	126						132	132				
GREEN ARROW	127	127						133	133				
⚠													
⚠													

NU = NOT USED

INPUT FILE POSITION LAYOUT

(front view)

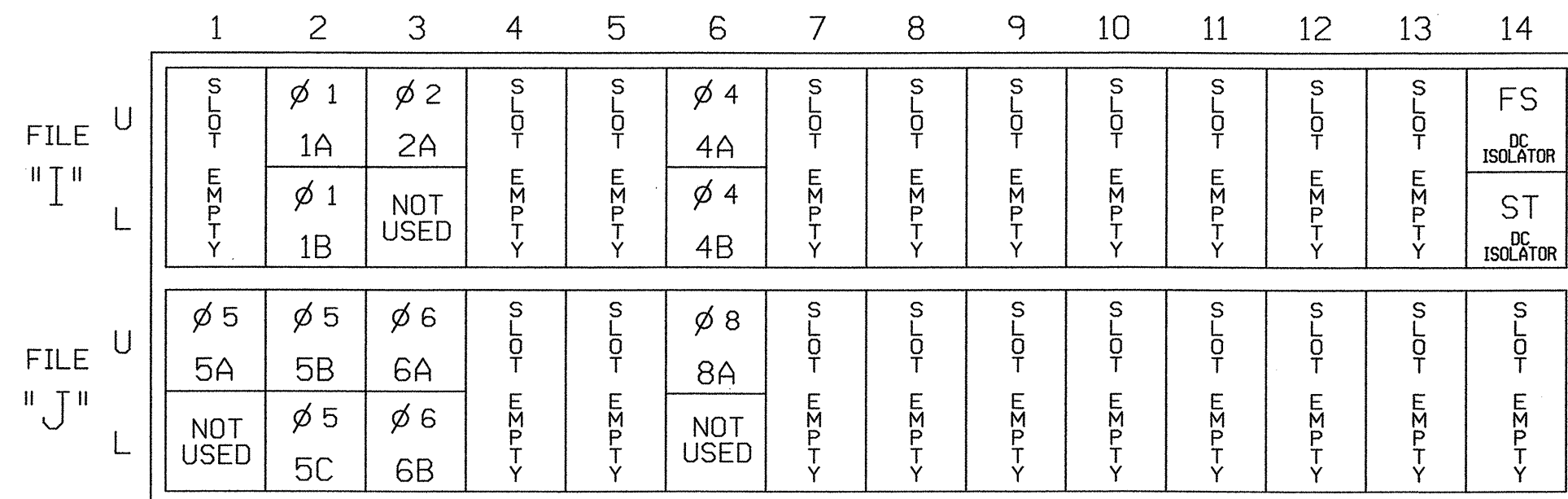

EX.: 1A, 2A, ETC. = LOOP NO.'S

FS = FLASH SENSE  
ST = STOP TIME

INPUT FILE CONNECTION & PROGRAMMING CHART

LOOP NO.	LOOP TERMINAL	INPUT FILE POS.	PIN NO.	INPUT ASSIGNMENT NO.	DETECTOR NO.	NEMA PHASE	CALL	EXTEND	FULL TIME DELAY	STRETCH TIME	DELAY TIME
1A	TB2-5,6	I2U	39	1	2	1	Y	Y	-	---	3
1B	TB2-7,8	I2L	43	5	12	1	Y	Y	-	---	15
2A	TB2-9,10	I3U	63	25	32	2	Y	Y	-	---	--
4A	TB4-9,10	I6U	41	3	4	4	Y	Y	-	---	3
4B	TB4-11,12	I6L	45	7	14	4	Y	Y	-	---	--
5A	TB3-1,2	J1U	55	17	5	5	Y	Y	-	---	3
5B	TB3-5,6	J2U	40	2	6	5	Y	Y	-	---	--
5C	TB3-7,8	J2L	44	6	16	5	Y	Y	-	---	15
6A	TB3-9,10	J3U	64	26	36	6	Y	Y	-	---	--
6B	TB3-11,12	J3L	77	39	46	6	Y	Y	-	---	--
8A	TB5-9,10	J6U	42	4	8	8	Y	Y	-	---	--

INPUT FILE POSITION LEGEND: J2L

FILE J  
SLOT 2  
LOWER

CONNECTOR WIRING DETAIL FOR ACCUTIME 2000 WITH RS232 INTERFACE

(make connections as shown)

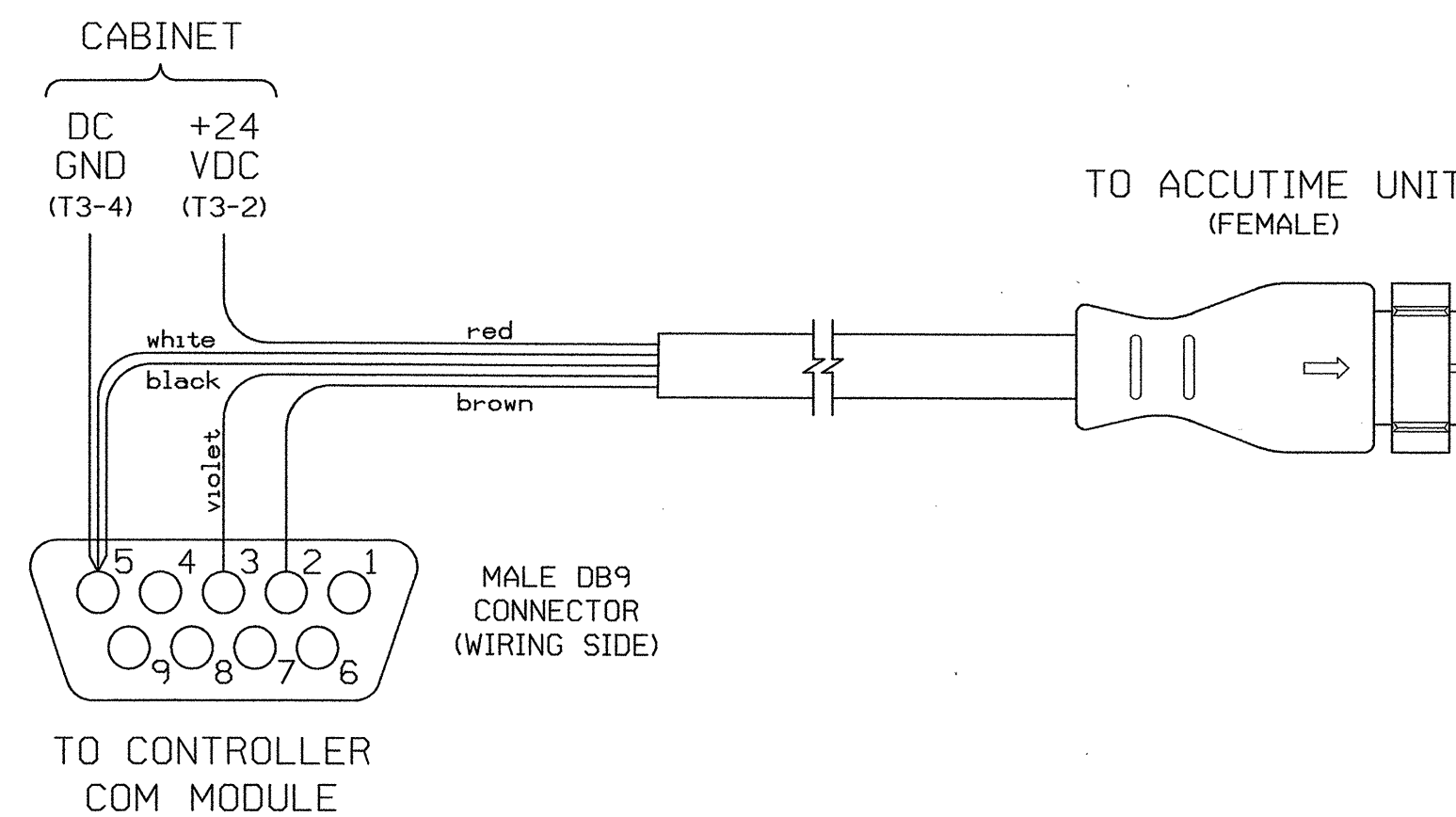

SIGNAL DESCRIPTION	12 CONDUCTOR CABLE COLOR	ACCUTIME CONNECTOR	DB9 TO CONTROLLER	CABINET CONNECTION
DC POWER	RED	PIN 1		T3-2
PORT B: RECEIVE	VIOLET	PIN 2	PIN 3	
PORT B: TRANSMIT	BROWN	PIN 4	PIN 2	
PORT A: RECEIVE	WHITE	PIN 6	PIN 5	
DC GROUND	BLACK	PIN 9	PIN 5	T3-4

NOTE: ALL OTHER WIRES IN THE ACCUWAVE CABLE ARE UNUSED AND SHOULD BE TIED OFF.

THE COM PORT USED BY THE ACCUTIME UNIT NEEDS TO BE CONFIGURED IN THE OASIS SOFTWARE USING THE SETTING BELOW:

- \* TRIMBLE TSIP GPS PROTOCOL
- \* 9600 BAUD
- \* 8 DATA BITS
- \* 1 STOP BIT
- \* ODD PARITY

THIS ELECTRICAL DETAIL IS FOR THE SIGNAL DESIGN: 03-095111  
 DESIGNED: SEPTEMBER 2003  
 SEALED: 1/7/2004  
 REVISED: TBD

**SEPI ENGINEERING GROUP**

2300 Rexwoods Drive  
 Suite 370  
 Raleigh, NC 27607  
 Tel:919-789-9977 Fax:789-9591

SIGNAL UPGRADE TEMPORARY DESIGN 1 CONSTRUCTION PHASE 1

ELECTRICAL AND PROGRAMMING DETAILS FOR: SR 1409 (MILITARY CUTOFF ROAD)

AT SIR TYLER DRIVE AND MAIN STREET (ACCESS "C")

PREPARED BY: M W YALCH  
 REVIEWED BY: J O DEATON

DATE: NOVEMBER 2003

DATE: 1/14/04

SEAL: NORTH CAROLINA PROFESSIONAL ENGINEER JAMES O. DEATON SEAL 07438

SIG. INVENTORY NO. 03-095111