

NAD 83

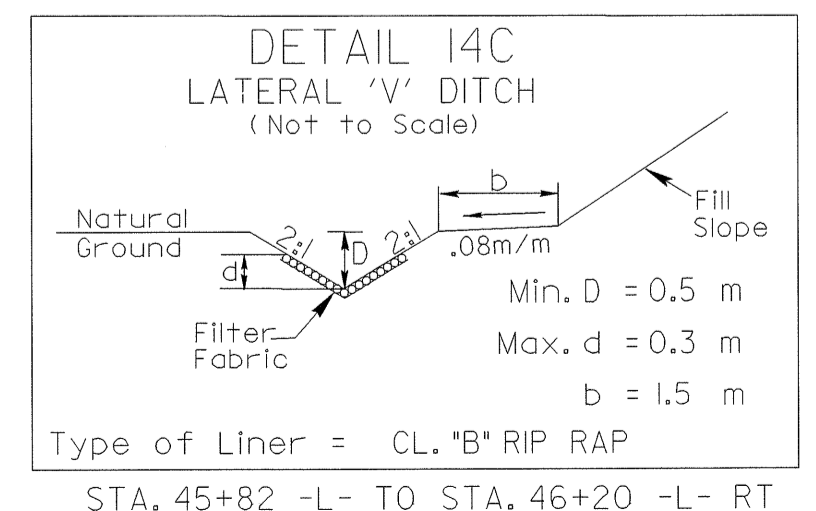

MATCHLINE STA. 44 + 00 -L- SEE SHEET UO-11

MATCHLINE STA. 47 + 60 -L- SEE SHEET UO-13

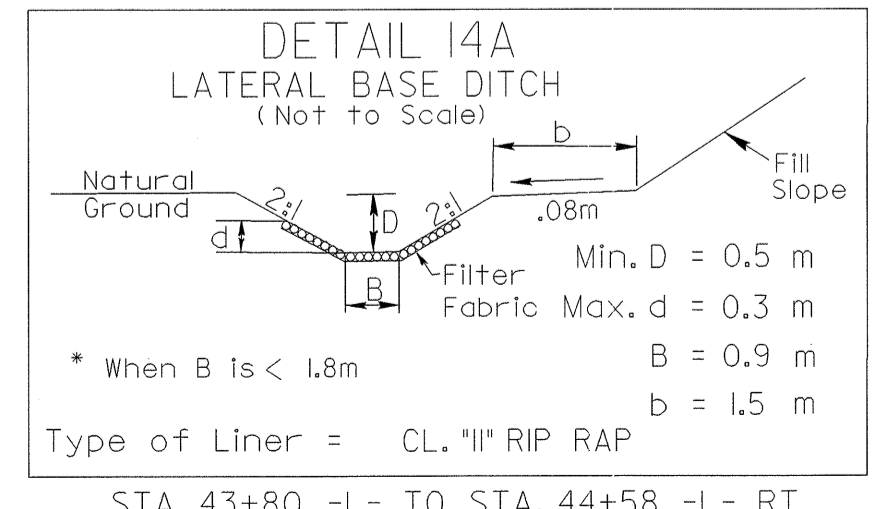
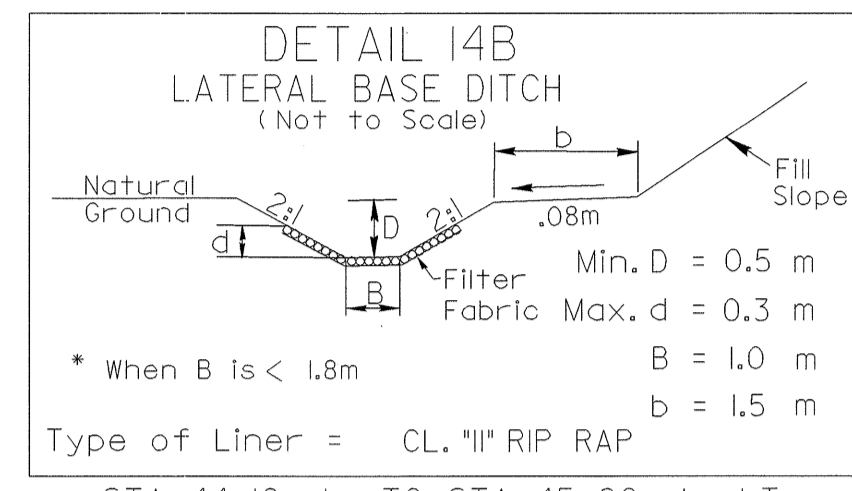
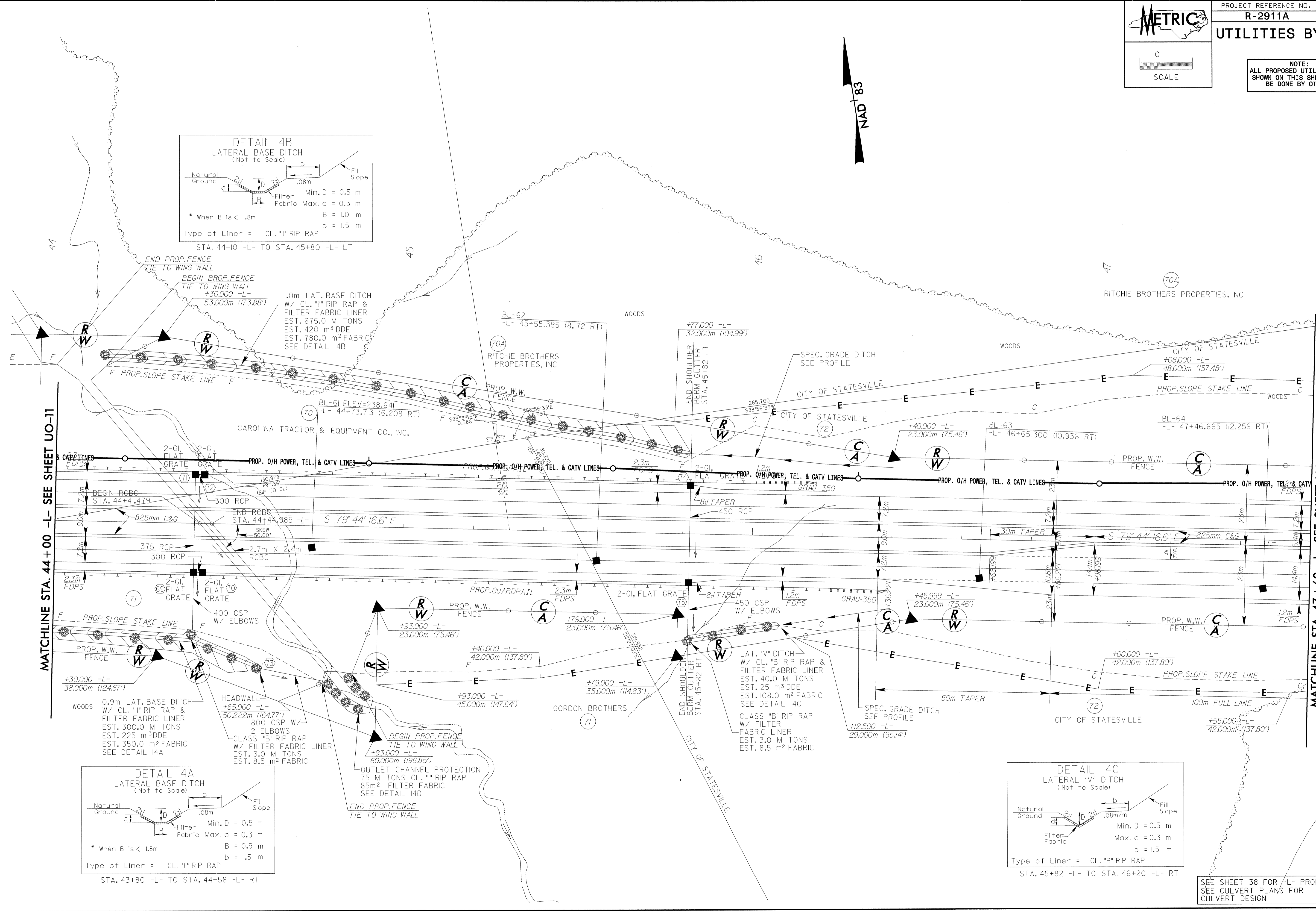

042587  
 22-JAN-2004 14:45  
 jnf: [unreadable] [unreadable] [unreadable]  
 [unreadable]

SEE SHEET 38 FOR -L- PROFILE  
 SEE CULVERT PLANS FOR  
 CULVERT DESIGN

Tc  
 +2  
 19.0  
 +00.00  
 18.00m