

PLAN OF TYPE III CORED SLAB UNIT (STAGE 1)

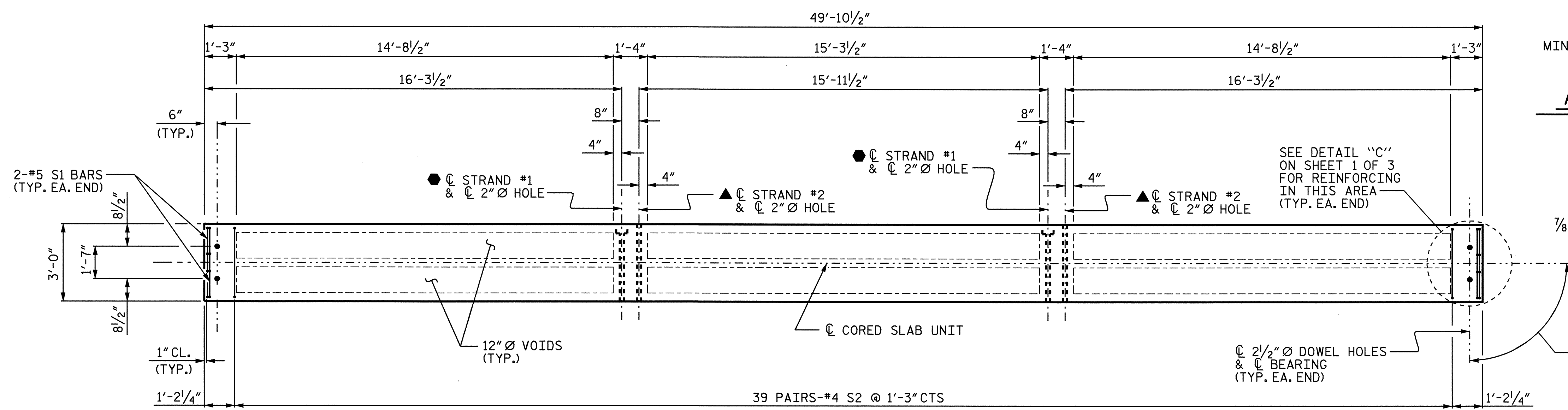

PLAN OF TYPE IV CORED SLAB UNIT (STAGE 1)

NOTES:

- FOR GROUTED RECESS SEE "SUPERSTRUCTURE TYPICAL SECTION" SHEET 2 OF 2.
- STRAND #1 GOES THRU 8 CORED SLAB UNITS (TO BE TENSIONED DURING STAGE 1 CONSTRUCTION)
- ▲ STRAND #2 GOES THRU ALL 13 CORED SLAB UNITS (TO BE TENSIONED DURING STAGE 2 CONSTRUCTION)
- ▲ STRAND #1 AND STRAND #2 ARE 1/2" Ø H.S. TRANSVERSE POST-TENSIONING STRANDS.
- THE #4 S2 AND #5 S3 BARS MAY BE SHIFTED SLIGHTLY IN ORDER TO MAINTAIN A 2" MIN. CLEARANCE TO THE 2" Ø HOLES.

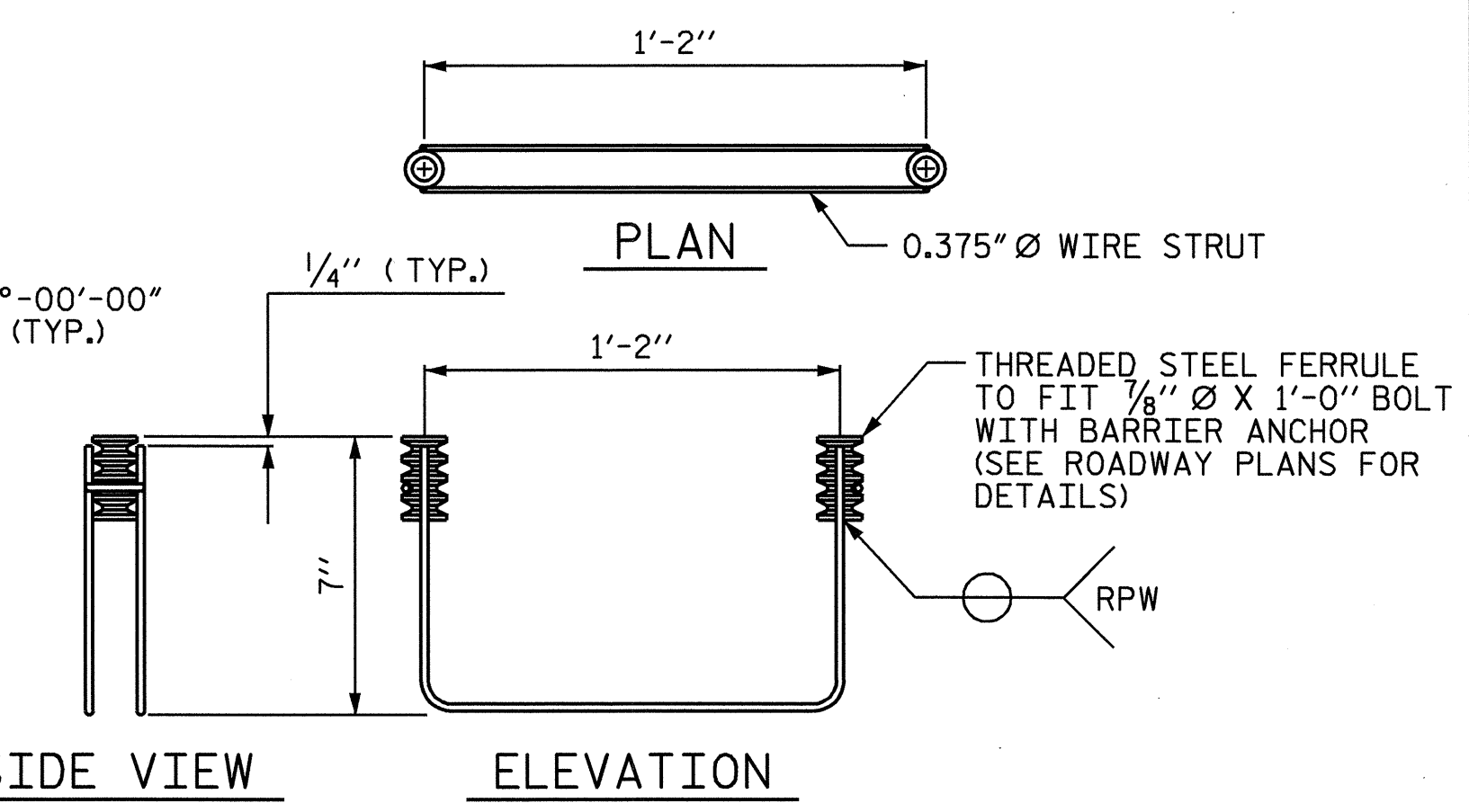

ANCHOR ASSEMBLY FOR ANCHORED PORTABLE CONCRETE BARRIER
(40 ASSEMBLIES REQUIRED IN THE CORED SLAB UNITS)
(10 ASSEMBLIES REQUIRED IN THE APPROACH SLABS)

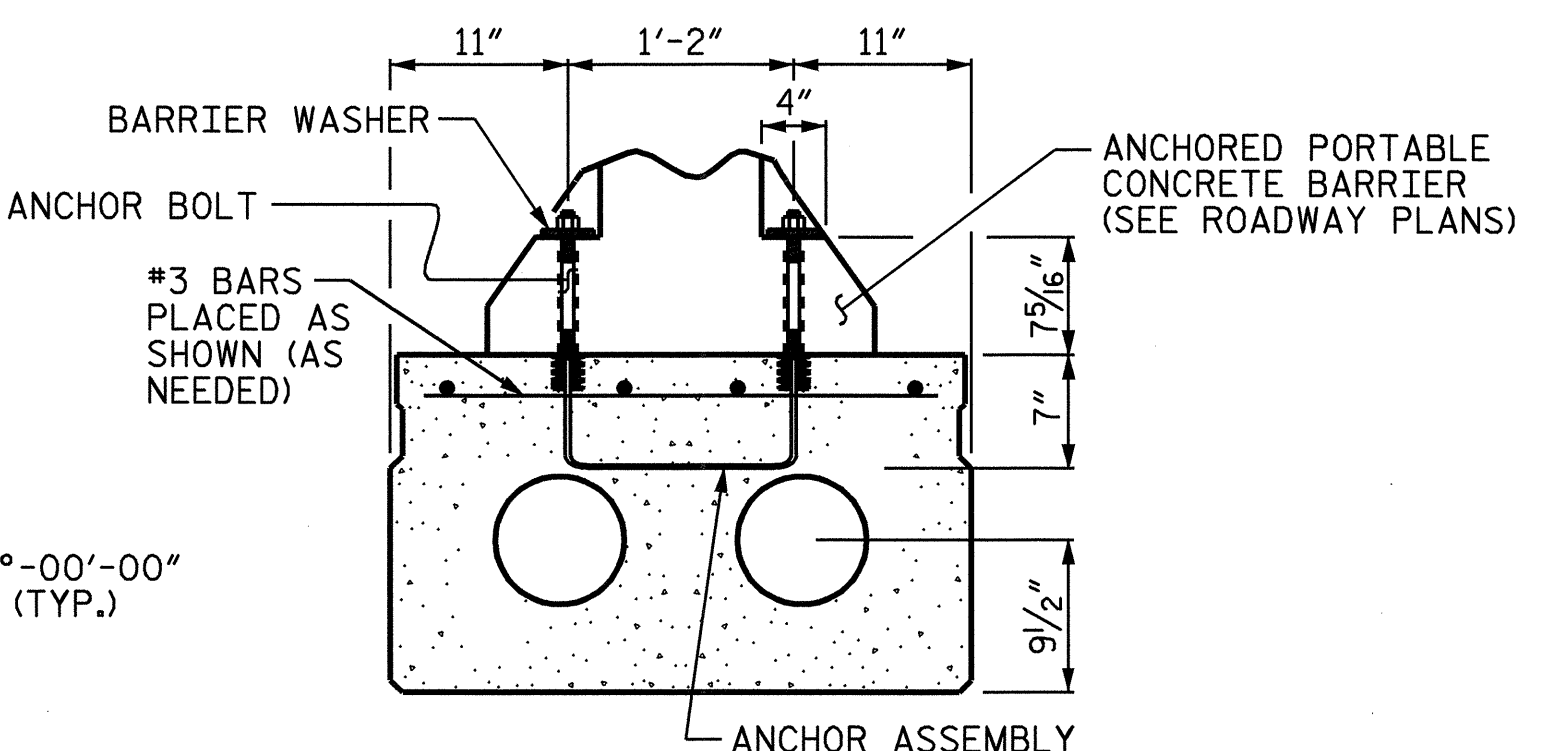

TYPE III CORED SLAB UNIT
(SHOWING PLACEMENT OF ANCHOR ASSEMBLY)
THE #3 BARS ARE INCIDENTAL AND THEIR COST SHALL BE INCLUDED IN THE PRICE BID FOR THE PRESTRESSED CONCRETE CORED SLABS.

ANCHOR ASSEMBLY NOTES:

- THE ANCHOR ASSEMBLY FOR PORTABLE CONCRETE BARRIER SHALL CONSIST OF THE FOLLOWING COMPONENTS :
- A. FERRULES SHALL BE MADE FROM STEEL MEETING THE REQUIREMENTS OF AASHTO M169, GRADE 12L14 AND SHALL HAVE A MINIMUM LENGTH OF THREADS OF 2 1/2\".
 - B. 2-7/8" Ø X 1'-0" ANCHOR BOLTS. ANCHOR BOLTS SHALL CONFORM TO THE REQUIREMENTS OF ASTM A307. ANCHOR BOLTS SHALL BE GALVANIZED. (AT THE CONTRACTOR'S OPTION, STAINLESS STEEL BOLTS MAY BE USED AS AN ALTERNATE FOR THE 7/8" Ø X 1'-0" GALVANIZED BOLTS. THEY SHALL CONFORM TO OR EXCEED THE MECHANICAL REQUIREMENTS OF ASTM A307. THE USE OF THIS ALTERNATE SHALL BE APPROVED BY THE ENGINEER.)
 - C. WIRE STRUTS SHOWN IN THE ANCHOR ASSEMBLY DETAIL ARE MINIMUM ALLOWABLE SIZE AND SHALL HAVE A MINIMUM TENSILE STRENGTH OF 100,000 P.S.I.
- ANCHOR ASSEMBLY WITH BOLTS SHALL BE ASSEMBLED IN THE SHOP. BOLT THREADS MAY BE RE CUT AS NECESSARY TO INSURE FIT.
- THE COST OF THE ANCHOR ASSEMBLY COMPLETE IN PLACE, SHALL BE INCLUDED, AS APPLICABLE, IN THE UNIT CONTRACT PRICE BID FOR 3'-0" X 1'-9" PRESTRESSED CONCRETE CORED SLAB OR LUMP SUM PRICE BID FOR APPROACH SLABS.

FERRULES TO BE PLUGGED DURING CASTING OF THE CORED SLAB UNITS OR POURING OF APPROACH SLAB AS RECOMMENDED BY THE MANUFACTURER.

AT THE CONTRACTOR'S OPTION, FERRULES WITH OPEN OR CLOSED ENDS MAY BE USED.

FOR 4" X 3 1/4" X 1/2" BARRIER WASHER TO BE USED WITH ANCHOR ASSEMBLY, SEE ROADWAY PLANS.

PAYMENT FOR ANCHORED PORTABLE CONCRETE BARRIER AND BARRIER WASHER ARE INCLUDED IN TRAFFIC CONTROL PAY ITEMS.

PROJECT NO. B-3348
HYDE COUNTY
STATION: 22+85.00 -L-

SHEET 2 OF 3

STATE OF NORTH CAROLINA
DEPARTMENT OF TRANSPORTATION
RALEIGH

3'-0" X 1'-9"
PRESTRESSED CONCRETE
CORED SLAB UNIT
DETAILS

REVISIONS				SHEET NO.	
NO.	BY:	DATE:	NO.	BY:	DATE:
1			3		
2			4		

TOTAL SHEETS: 76

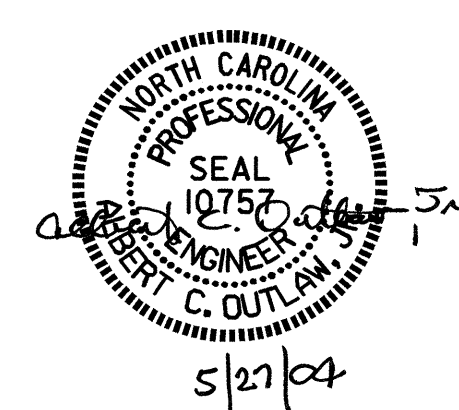

DRAWN BY : P.C. BREWER DATE : 1/15/03
CHECKED BY : T.N. CARROLL DATE : 3/10/03