

BILL OF MATERIAL APPROACH SLAB @ END BENT 1

BAR	NO.	SIZE	TYPE	LENGTH	WEIGHT	BAR	NO.	SIZE	TYPE	LENGTH	WEIGHT	BAR	NO.	SIZE	TYPE	LENGTH	WEIGHT	BAR	NO.	SIZE	TYPE	LENGTH	WEIGHT	BAR	NO.	SIZE	TYPE	LENGTH	WEIGHT	BAR	NO.	SIZE	TYPE	LENGTH	WEIGHT
*A1	6	#5	STR	37'-8"	236	*A133	2	#5	STR	16'-1"	34	A223	4	#4	STR	18'-3"	49	*B15	2	#6	STR	32'-1"	96	B59	2	#8	STR	34'-5"	184	*G1	1	#5	STR	43'-3"	45
*A100	3	#5	STR	36'-5"	114	*A134	2	#5	STR	14'-4"	30	A224	4	#4	STR	17'-5"	47	*B16	2	#6	STR	31'-9"	95	B60	2	#8	STR	34'-1"	182	*G2	1	#5	STR	51'-5"	54
*A101	3	#5	STR	34'-10"	109	*A135	2	#5	STR	12'-7"	26	A225	4	#4	STR	16'-6"	44	*B17	2	#6	STR	31'-5"	94	B61	2	#8	STR	33'-9"	180						
*A102	3	#5	STR	33'-3"	104	*A136	2	#5	STR	10'-11"	23	A226	2	#4	STR	29'-5"	39	*B18	2	#6	STR	31'-0"	93	B62	2	#8	STR	33'-5"	178	*S1	48	#5	STR	3'-3"	163
*A103	3	#5	STR	31'-8"	99	*A137	2	#5	STR	9'-2"	19	A227	2	#4	STR	27'-8"	37	*B19	2	#6	STR	30'-8"	92	B63	2	#8	STR	33'-0"	176	*S2	40	#5	1	4'-1"	170
*A104	3	#5	STR	30'-0"	94	*A138	2	#5	STR	7'-6"	16	A228	2	#4	STR	25'-11"	35	*B20	2	#6	STR	30'-4"	91	B64	2	#8	STR	32'-8"	174	*S3	20	#5	2	2'-3"	47
*A105	3	#5	STR	28'-5"	89	*A139	2	#5	STR	5'-10"	12	A229	2	#4	STR	24'-2"	32	*B21	2	#6	STR	29'-11"	90	B65	2	#8	STR	32'-4"	173						
*A106	3	#5	STR	26'-10"	84	*A140	2	#5	STR	4'-1"	9	A230	2	#4	STR	22'-5"	30	*B22	2	#6	STR	29'-7"	89	B66	2	#8	STR	31'-11"	170						
*A107	3	#5	STR	25'-2"	79	*A141	4	#5	STR	2'-5"	10	A231	2	#4	STR	20'-6"	27	*B23	2	#6	STR	29'-3"	88	B67	2	#8	STR	31'-7"	169						
*A108	3	#5	STR	23'-7"	74							A232	2	#4	STR	18'-9"	25	*B24	2	#6	STR	28'-10"	87	B68	2	#8	STR	31'-3"	167						
*A109	3	#5	STR	21'-11"	69	A2	12	#4	STR	19'-9"	158	A233	2	#4	STR	17'-1"	23	*B25	2	#6	STR	28'-6"	86	B69	2	#8	STR	30'-11"	165						
*A110	3	#5	STR	20'-4"	64	A200	6	#4	STR	19'-2"	77	A234	2	#4	STR	15'-4"	20	*B26	2	#6	STR	28'-2"	85	B70	2	#8	STR	30'-6"	163						
*A111	3	#5	STR	18'-8"	58	A201	6	#4	STR	18'-4"	73	A235	2	#4	STR	13'-7"	18	*B27	2	#6	STR	27'-10"	84	B71	2	#8	STR	30'-2"	161						
*A112	3	#5	STR	17'-1"	53	A202	6	#4	STR	17'-7"	70	A236	2	#4	STR	11'-11"	16	*B28	2	#6	STR	27'-5"	82	B72	2	#8	STR	29'-10"	159						
*A113	3	#5	STR	15'-5"	48	A203	6	#4	STR	16'-9"	67	A237	2	#4	STR	10'-2"	14	*B29	2	#6	STR	27'-1"	81	B73	2	#8	STR	29'-5"	157						
*A114	3	#5	STR	13'-9"	43	A204	3	#4	STR	30'-0"	60	A238	2	#4	STR	8'-6"	11	*B30	2	#6	STR	26'-9"	80	B74	2	#8	STR	29'-1"	155						
*A115	3	#5	STR	12'-4"	39	A205	3	#4	STR	28'-5"	57	A239	2	#4	STR	6'-9"	9	*B31	2	#6	STR	26'-4"	79	B75	2	#8	STR	28'-9"	153						
*A116	3	#5	STR	10'-8"	33	A206	3	#4	STR	26'-10"	54	A240	2	#4	STR	5'-1"	7	*B32	2	#6	STR	26'-0"	78	B76	2	#8	STR	28'-4"	151						
*A117	3	#5	STR	9'-0"	28	A207	3	#4	STR	25'-2"	50	A241	5	#4	STR	3'-5"	11	*B33	2	#6	STR	25'-8"	77	B77	2	#8	STR	28'-0"	150						
*A118	3	#5	STR	7'-4"	23	A208	3	#4	STR	23'-7"	47						*B34	2	#6	STR	25'-3"	76	B78	2	#8	STR	27'-8"	148							
*A119	3	#5	STR	5'-8"	18	A209	3	#4	STR	21'-11"	44	*B1	2	#6	STR	37'-0"	111	*B35	2	#6	STR	24'-11"	75	B79	2	#8	STR	27'-3"	146						
*A120	3	#5	STR	4'-0"	13	A210	3	#4	STR	20'-4"	41	*B2	2	#6	STR	36'-8"	110	*B36	2	#6	STR	24'-6"	74	B80	2	#8	STR	26'-11"	144						
*A121	6	#5	STR	2'-4"	15	A211	3	#4	STR	18'-8"	37	*B3	2	#6	STR	36'-4"	109	*B37	2	#6	STR	24'-2"	73	B81	2	#8	STR	26'-7"	142						
*A122	2	#5	STR	35'-5"	74	A212	3	#4	STR	17'-1"	34	*B4	2	#6	STR	36'-0"	108	*B38	2	#6	STR	23'-10"	72	B82	2	#8	STR	26'-2"	140						
*A123	2	#5	STR	33'-8"	70	A213	3	#4	STR	15'-5"	31	*B5	2	#6	STR	35'-8"	107							B83	2	#8	STR	25'-10"	138						
*A124	2	#5	STR	31'-11"	67	A214	3	#4	STR	13'-9"	28	*B6	2	#6	STR	33'-3"	106	B50	2	#8	STR	37'-7"	201	B84	2	#8	STR	25'-6"	136						
*A125	2	#5	STR	30'-2"	63	A215	3	#4	STR	12'-4"	25	*B7	2	#6	STR	34'-11"	105	B51	2	#8	STR	37'-3"	199	B85	2	#8	STR	25'-1"	134						
*A126	2	#5	STR	28'-5"	59	A216	3	#4	STR	10'-8"	21	*B8	2	#6	STR	34'-7"	104	B52	2	#8	STR	36'-11"	197	B86	2	#8	STR	24'-9"	132						
*A127	2	#5	STR	26'-8"	56	A217	3	#4	STR	9'-0"	18	*B9	2	#6	STR	34'-3"	103	B53	2	#8	STR	36'-7"	195	B87	2	#8	STR	24'-5"	130						
*A128	2	#5	STR	24'-11"	52	A218	3	#4	STR	7'-4"	15	*B10	2	#6	STR	33'-10"	102	B54	2	#8	STR	36'-2"	193												
*A129	2	#5	STR	23'-2"	48	A219	3	#4	STR	5'-8"	11	*B11	2	#6	STR	33'-6"	101	B55	2	#8	STR	35'-10"	191	*B100	7	#5	STR	12'-6"	91						
*A130	2	#5	STR	21'-5"	45	A220	3	#4	STR	4'-0"	8	*B12	2	#6	STR	33'-2"	100	B56	2	#8	STR	35'-6"	190	*B101	7	#5	STR	11'-8"	85						
*A131	2	#5	STR	19'-6"	41	A221	6	#4	STR	2'-4"	9	*B13	2	#6	STR	32'-10"	99	B57	2	#8	STR	35'-2"	188	*B102	1	#5	3	7'-4"	8						
*A132	2	#5	STR	17'-9"	37	A222	4	#4	STR	19'-2"	51	*B14	2	#6	STR	32'-5"	97	B58	2	#8	STR	34'-10"	186	*B103	1	#5	3	6'-6"	7						

BAR TYPES (CONT.)

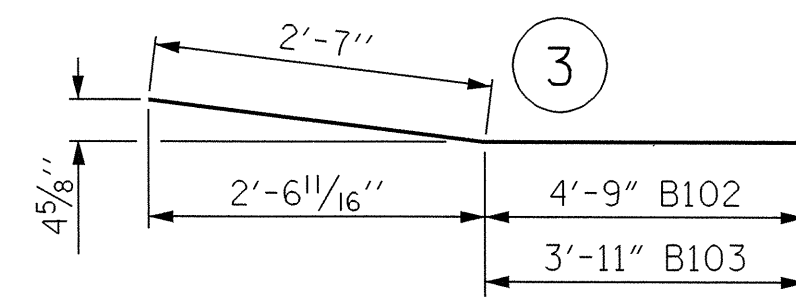

REINFORCING STEEL	LBS.	7877
*EPOXY COATED REINFORCING STEEL	LBS.	6526

CLASS AA CONCRETE BREAKDOWN		
POUR 1 SLAB	C. Y.	45.2
POUR 2 RAIL	C. Y.	2.1
CLASS AA CONCRETE	C. Y.	47.3

BAR TYPES

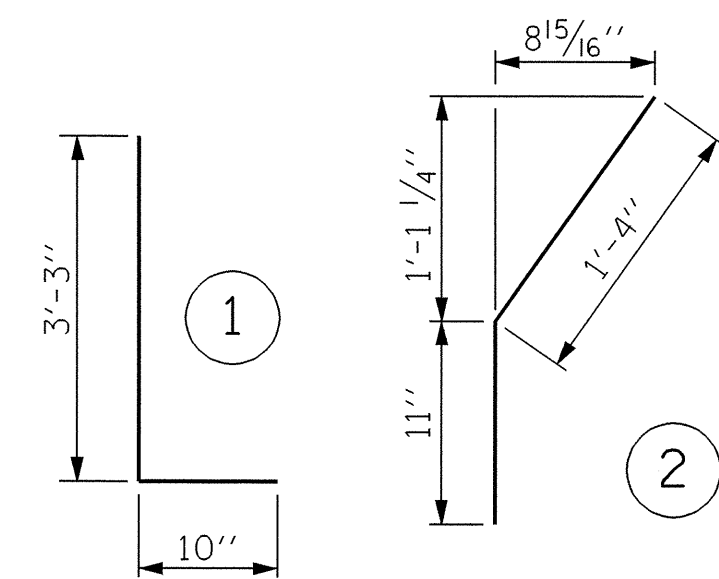

BILL OF MATERIAL APPROACH SLAB @ END BENT 2

BAR	NO.	SIZE	TYPE	LENGTH	WEIGHT	BAR	NO.	SIZE	TYPE	LENGTH	WEIGHT	BAR	NO.	SIZE	TYPE	LENGTH	WEIGHT	BAR	NO.	SIZE	TYPE	LENGTH	WEIGHT	BAR	NO.	SIZE	TYPE	LENGTH	WEIGHT	BAR	NO.	SIZE	TYPE	LENGTH	WEIGHT
*A1	6	#5	STR	37'-8"	236	*A133	2	#5	STR	10'-6"	22	A225	2	#4	STR	29'-9"	40	*B12	2	#6	STR	28'-4"	85	B56	2	#8	STR	29'-9"	159	*B101	7	#5	STR	12'-6"	91
*A100	3	#5	STR	34'-2"	107	*A134	2	#5	STR	9'-3"	19	A226	2	#4	STR	28'-5"	38	*B13	2	#6	STR	28'-2"	85	B57	2	#8	STR	29'-7"	158	*B102	1	#5	3	6'-6"	7
*A101	3	#5	STR	31'-8"	99	*A135	2	#5	STR	7'-11"	17	A227	2	#4	STR	27'-1"	36	*B14	2	#6	STR	27'-11"	84	B58	2	#8	STR	29'-5"	157	*B103	1	#5	3	7'-7"	8
*A102	3	#5	STR	29'-1"	91	*A136	2	#5	STR	6'-8"	14	A228	2	#4	STR	25'-9"	34	*B15	2	#6	STR	27'-9"	83	B59	2	#8	STR	29'-3"	156						
*A103	3	#5	STR	26'-7"	83	*A137	2	#5	STR	5'-5"	11	A229	2	#4	STR	24'-6"	33	*B16	2	#6	STR	27'-7"	83	B60	2	#8	STR	29'-1"	155	*G1	1	#5	STR	47'-9"	50
*A104	3	#5	STR	24'-0"	75	*A138	2	#5	STR	4'-2"	9	A230	2	#4	STR	23'-2"	31	*B17	2	#6	STR	27'-5"	82	B61	2	#8	STR	28'-11"	154	*G2	1	#5	STR	43'-4"	45
*A105	3	#5	STR	21'-5"	67	*A139	6	#5	STR	2'-10"	18	A231	2	#4	STR	21'-11"	29	*B18	2	#6	STR	27'-3"	82	B62	2	#8	STR	28'-8"	153						
*A106	3	#5	STR	18'-8"	58	A2	12	#4	STR	19'-9"	158	A232	2	#4	STR	20'-7"	27	*B19	2	#6	STR	27'-1"	81	B63	2	#8	STR	28'-6"	152	*S1	48	#5	STR	3'-3"	163
*A107	3	#5	STR	16'-1"	50	A200	4	#4	STR	18'-11"	51	A233	2	#4	STR	19'-3"	26	*B20	2	#6	STR	26'-11"	81	B64	2	#8	STR	28'-4"	151	*S2	40	#5	1	4'-1"	170
*A108	3	#5	STR	13'-5"	42	A201	4	#4	STR	18'-1"	48	A234	2	#4	STR	18'-0"	24	*B21	2	#6	STR	26'-9"	80	B65	2	#8	STR	28'-2"	150	*S3	20	#5	2	2'-3"	47
*A109	3	#5	STR	10'-10"	34	A202	4	#4	STR	17'-3"	46	A235	2	#4	STR	16'-8"	22	*B22	2	#6	STR	26'-7"	80	B66	2	#8	STR	28'-0"	150						
*A110	3	#5	STR	8'-3"	26	A203	4	#4	STR	16'-5"	44	A236	2	#4	STR	15'-7"	21	*B23	2	#6	STR	26'-4"	79	B67	2	#8									