

**NOTES**  
 FOR -DET-B- PROFILE SEE SHEET 55  
 ALL DRIVEWAY RADII ARE 20' UNLESS NOTED

PI Sta 154+45.09  
 $\Delta = 19^{\circ}34'26.1''$  (RT)  
 $D = 0^{\circ}29'53.6''$   
 $L = 3,928.74$   
 $T = 1,983.70'$   
 $R = 11,500.00'$   
 SE = NC

PIs Sta 175+23.49  
 $\Theta_s = 0^{\circ}59'47.7''$   
 $L_s = 400.05'$   
 $LT = 266.70'$   
 $ST = 133.35'$

PI Sta 185+35.85  
 $\Delta = 0^{\circ}25'30.1''$  (LT)  
 $D = 0^{\circ}02'50.0''$   
 $L = 900.18'$   
 $T = 450.09'$   
 $R = 121,351.16'$   
 SE = NC

MATCHLINE \*\* SEE SHEET 25 \*\*

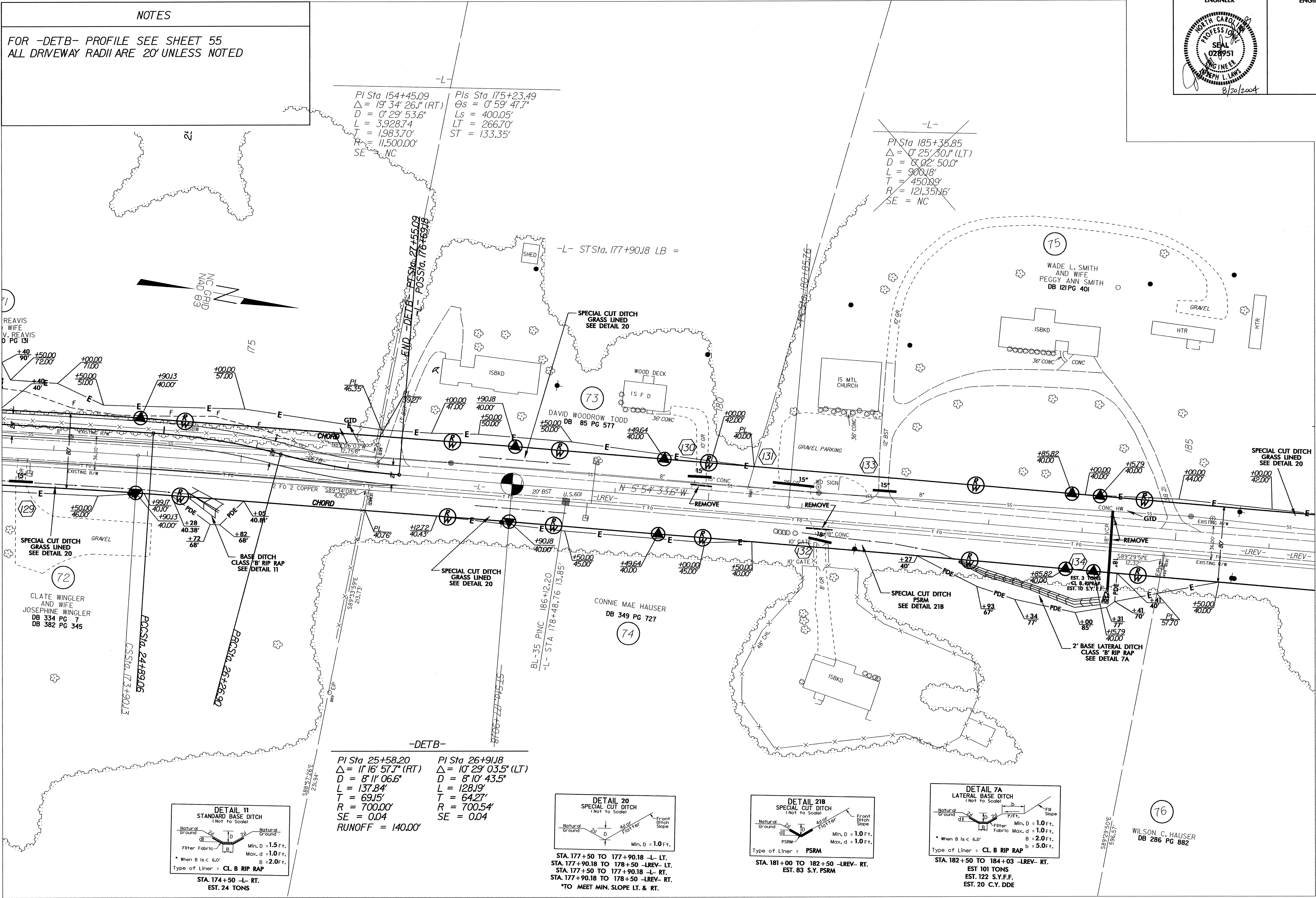

**-DET-B-**  
 PI Sta 25+58.20  
 $\Delta = 11^{\circ}16'57.7''$  (RT)  
 $D = 8^{\circ}10'06.6''$   
 $L = 137.84'$   
 $T = 69.15'$   
 $R = 700.00'$   
 $SE = 0.04$   
**RUNOFF = 140.00'**

PI Sta 26+91.18  
 $\Delta = 10^{\circ}29'03.5''$  (LT)  
 $D = 8^{\circ}10'43.5''$   
 $L = 128.19'$   
 $T = 64.27'$   
 $R = 700.54'$   
 $SE = 0.04$

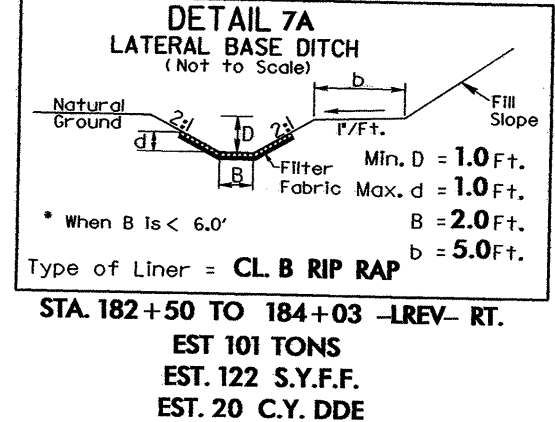
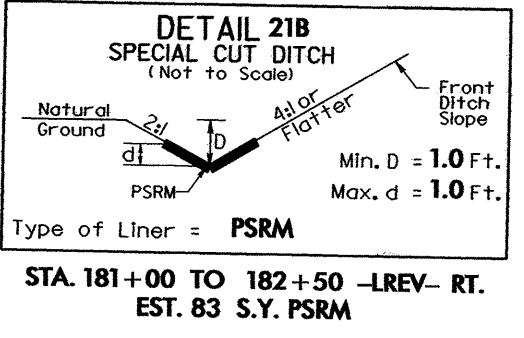
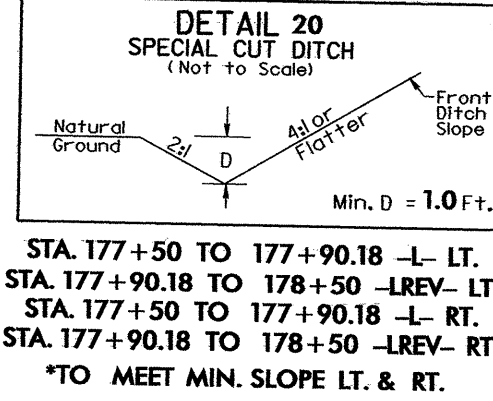
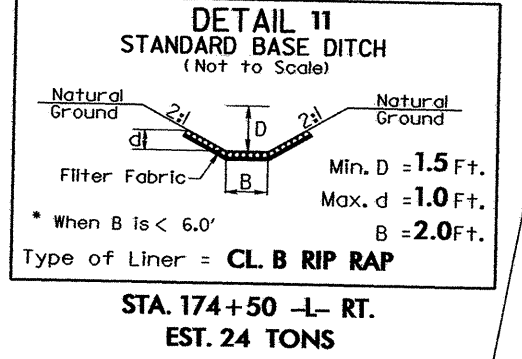

7/2/99  
 20-AUG-2004 14:54  
 D:\RDY\F3427\ps26DE TB-3427.psh  
 dw AT