

NOTE:
TEMPORARY SILT FENCE SHALL BE INSTALLED A MINIMUM OF 3 FEET FROM TOE OF FILL IN WETLAND AREAS

NOTE:
PLACE TEMPORARY ROCK SEDIMENT DAMS TYPE-B AND TEMPORARY ROCK SILT CHECKS TYPE-A AT DRAINAGE OUTLETS.

CLEARING AND GRUBBING EROSION CONTROL FOR CONSTRUCTION SHEET 11

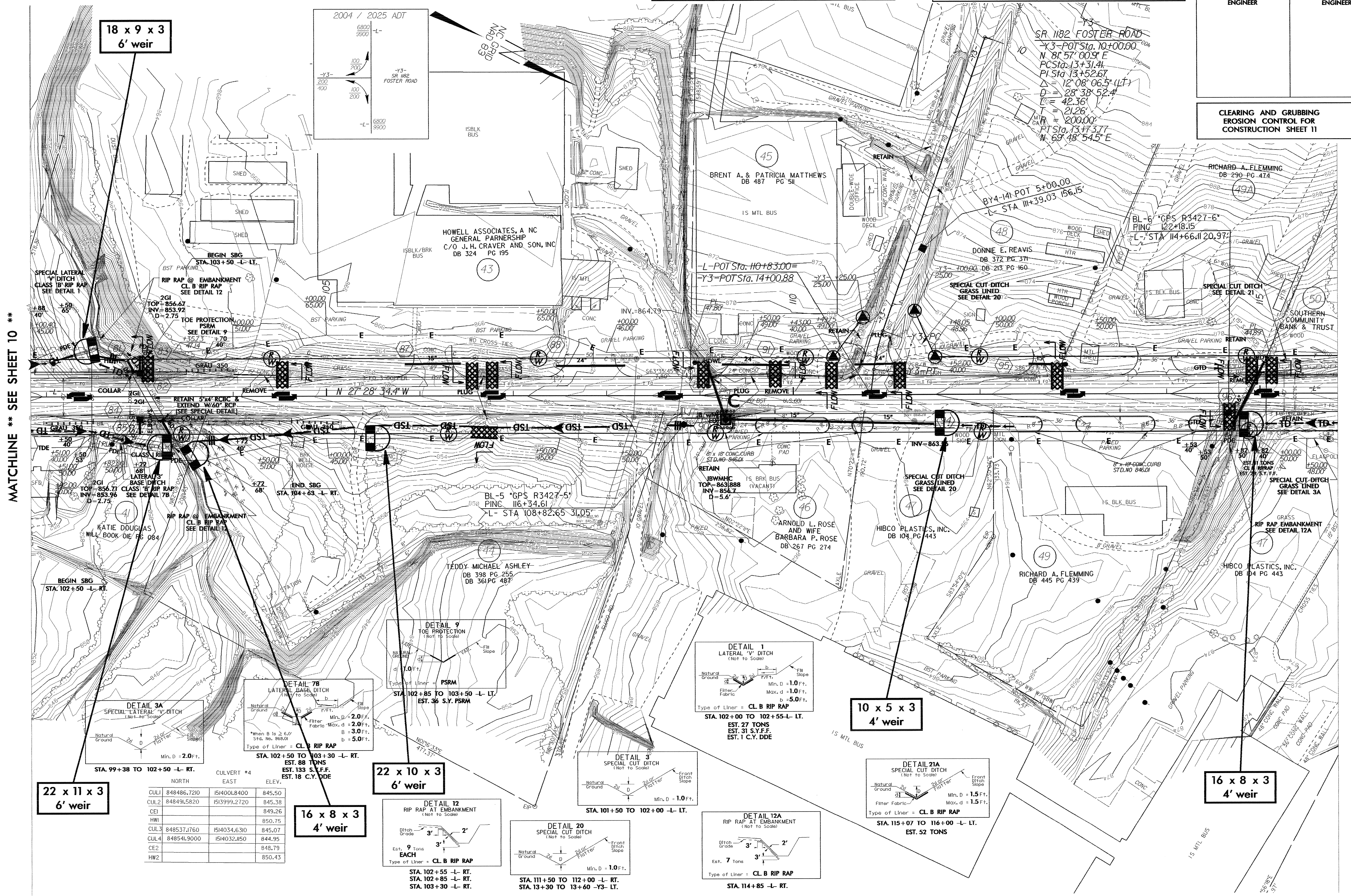

MATCHLINE ** SEE SHEET 10 **

MATCHLINE ** SEE SHEET 12 **

18 x 9 x 3
6' weir

10 x 5 x 3
4' weir

22 x 11 x 3
6' weir

16 x 8 x 3
4' weir

22 x 10 x 3
6' weir

16 x 8 x 3
4' weir

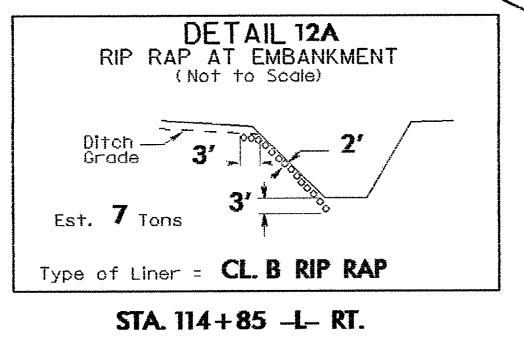
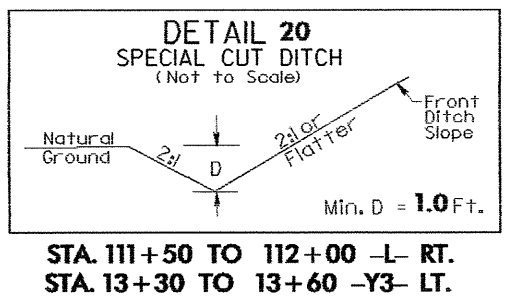
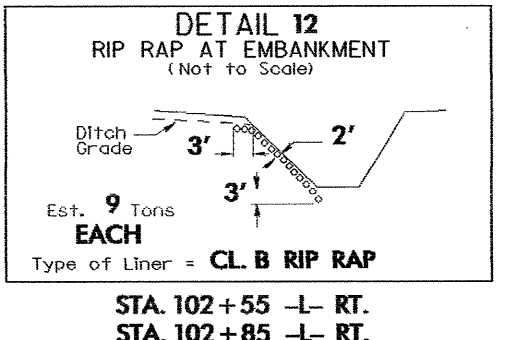
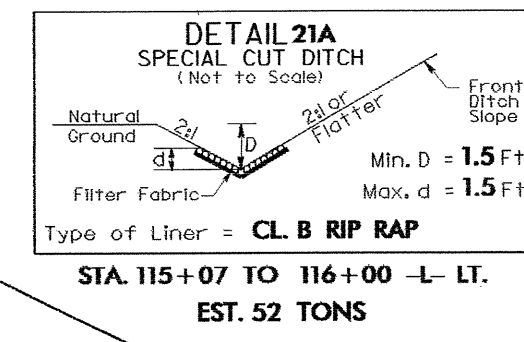
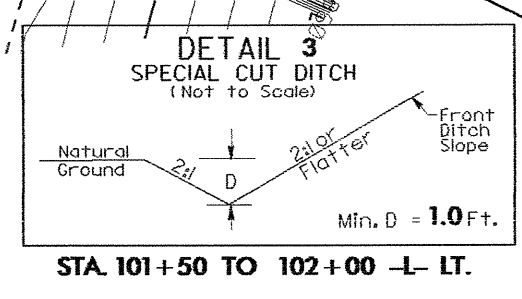
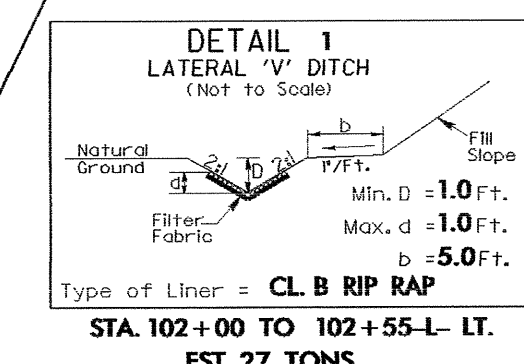
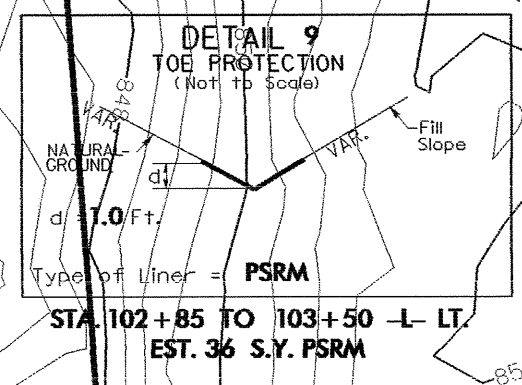
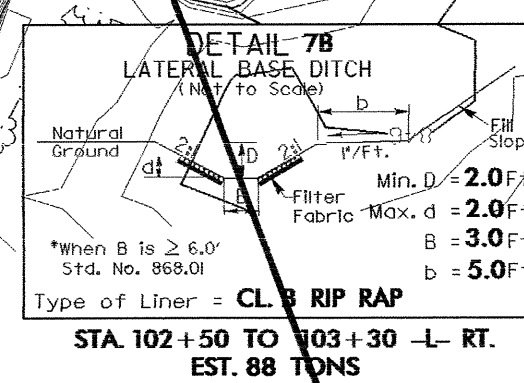
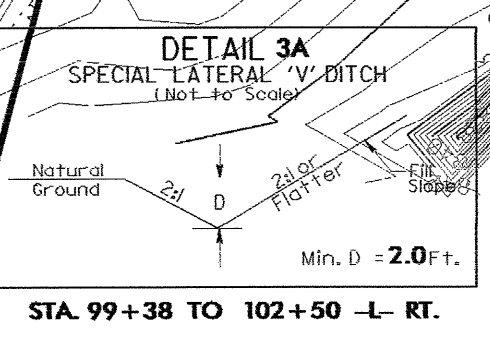

	NORTH	EAST	ELEV.
CUL1	848486.7210	1514001.8400	845.50
CUL2	848491.5820	1513999.2720	845.38
CE1			849.26
HW1			850.75
CUL3	848537.1760	1514034.6310	845.07
CUL4	848541.9000	1514032.1150	844.95
CE2			848.79
HW2			850.43