

HALF SECTION AT INTERMEDIATE DIAPHRAGM      HALF SECTION AT VOIDS

**TYPICAL SECTION**

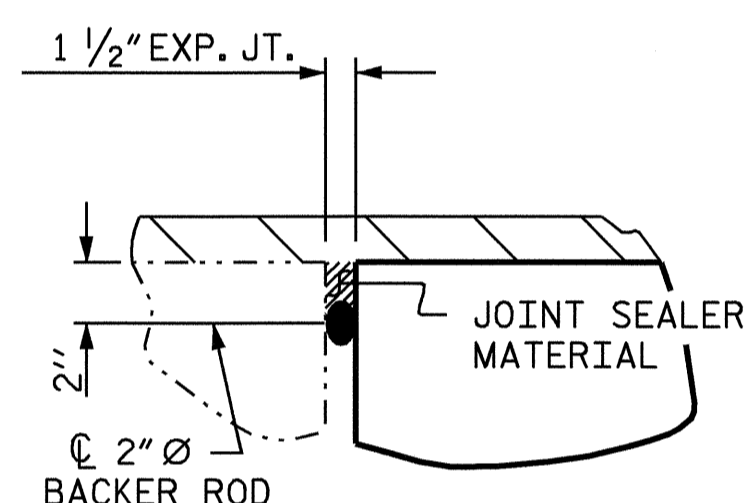

**DETAIL "A"**

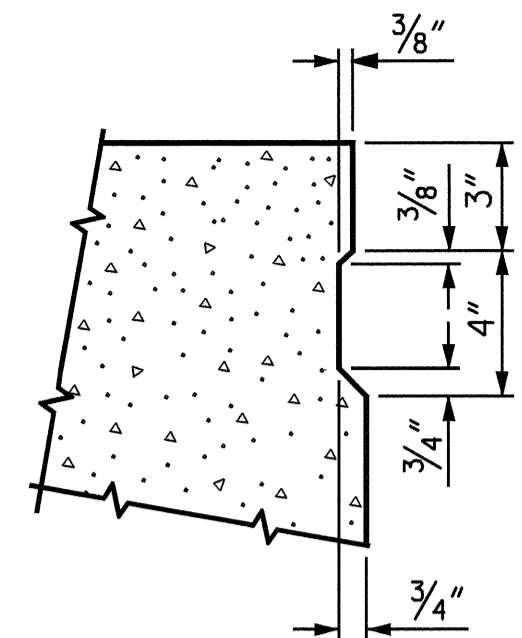

**SHEAR KEY DETAIL**

NOTE: OMIT SHEAR KEY ON OUTSIDE FACE OF EXTERIOR CORED SLABS.

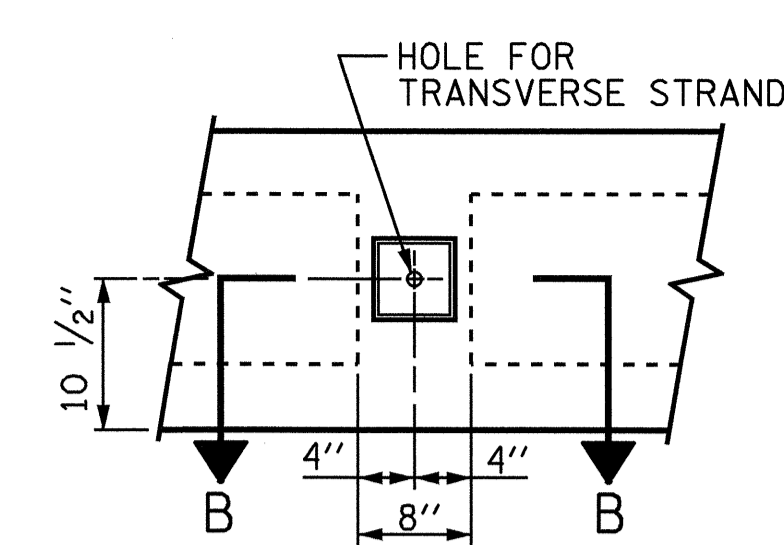

**ELEVATION VIEW**

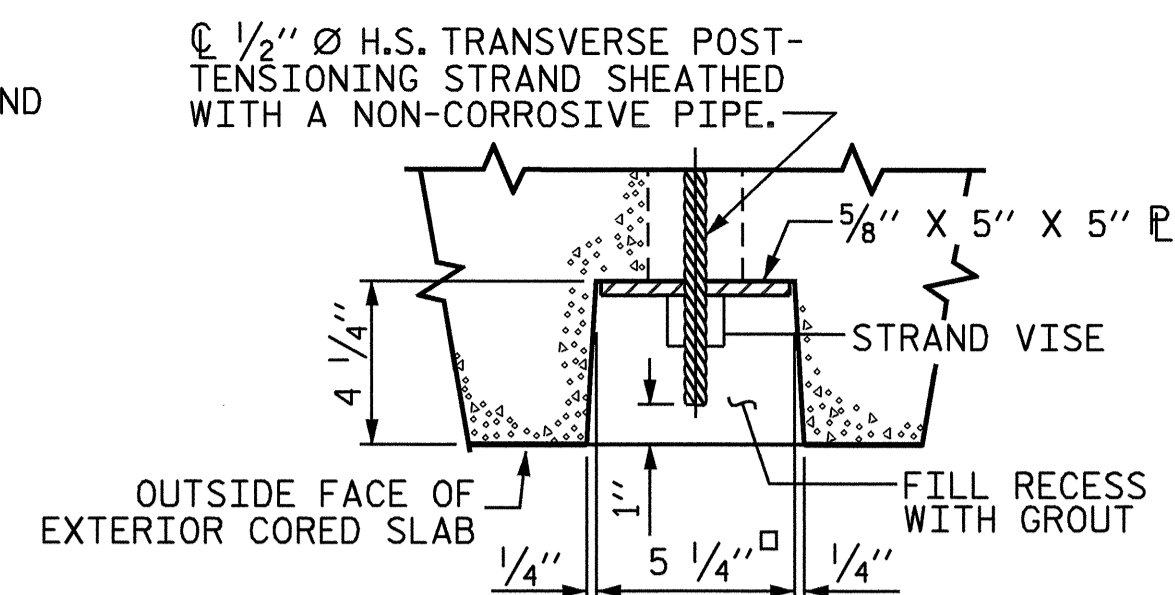

**SECTION B-B**

**GROUTED RECESS AT END OF POST-TENSIONED STRAND CORED SLAB**

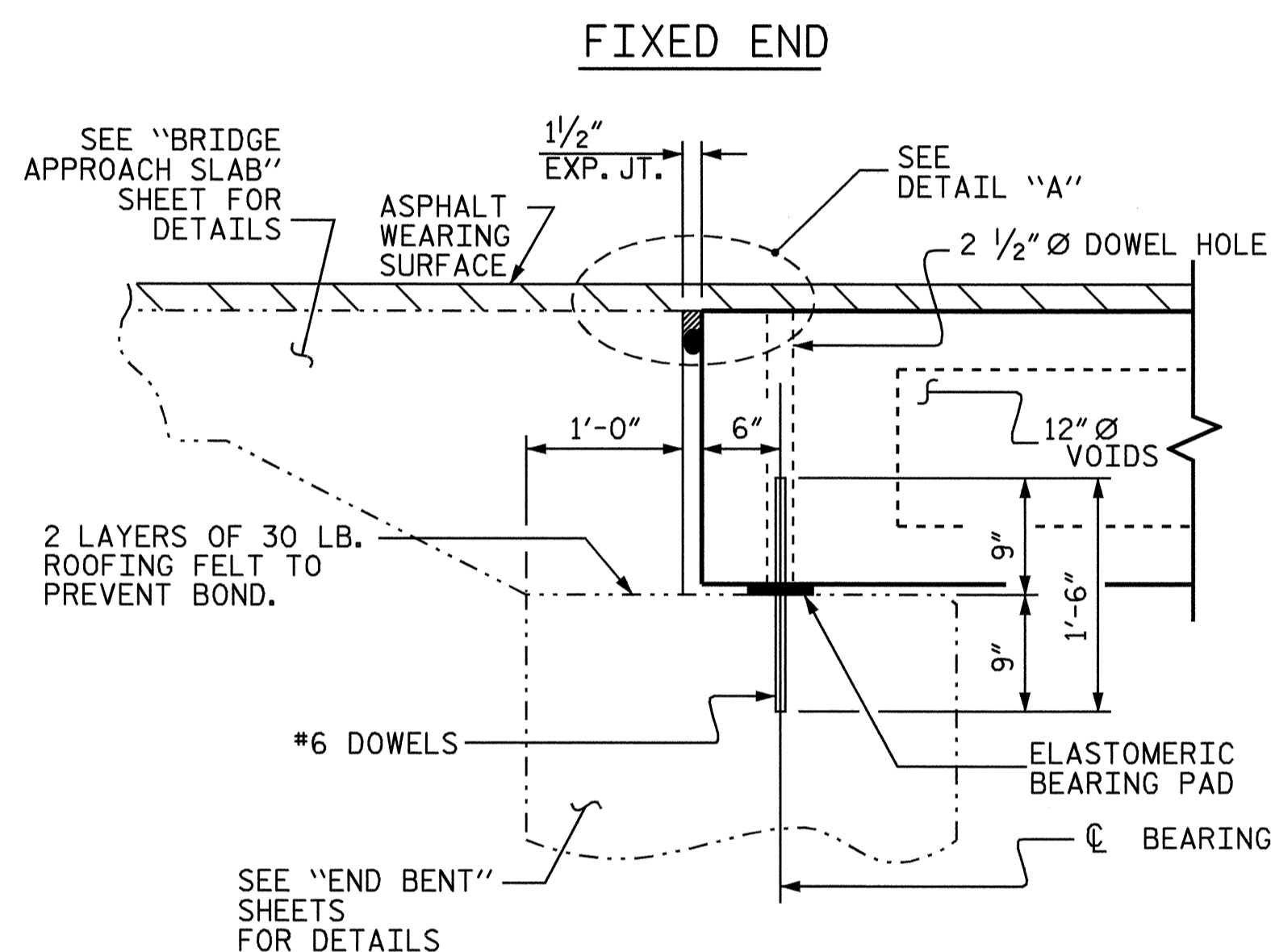

**SECTION AT END BENT**

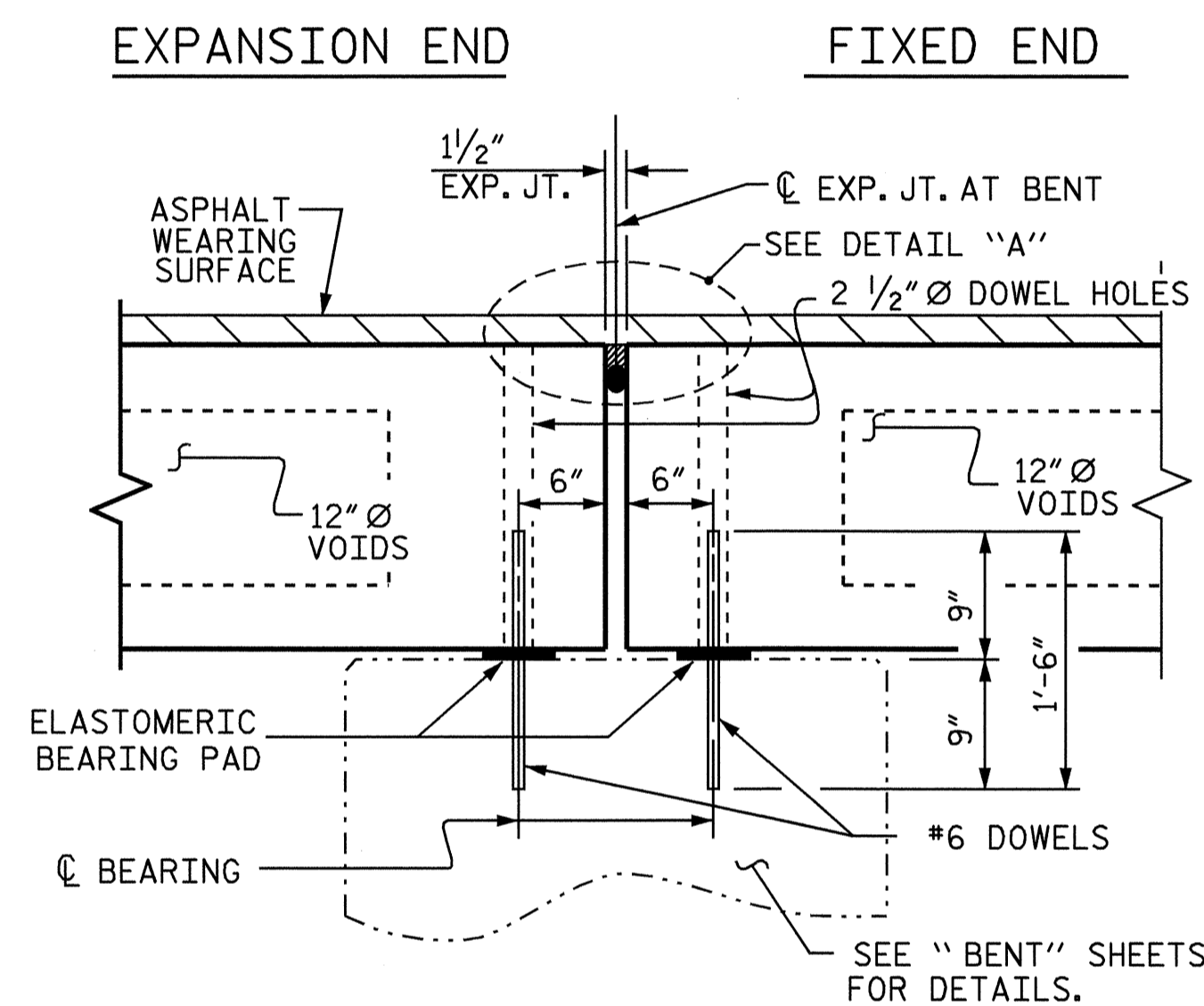

**SECTION AT BENT**

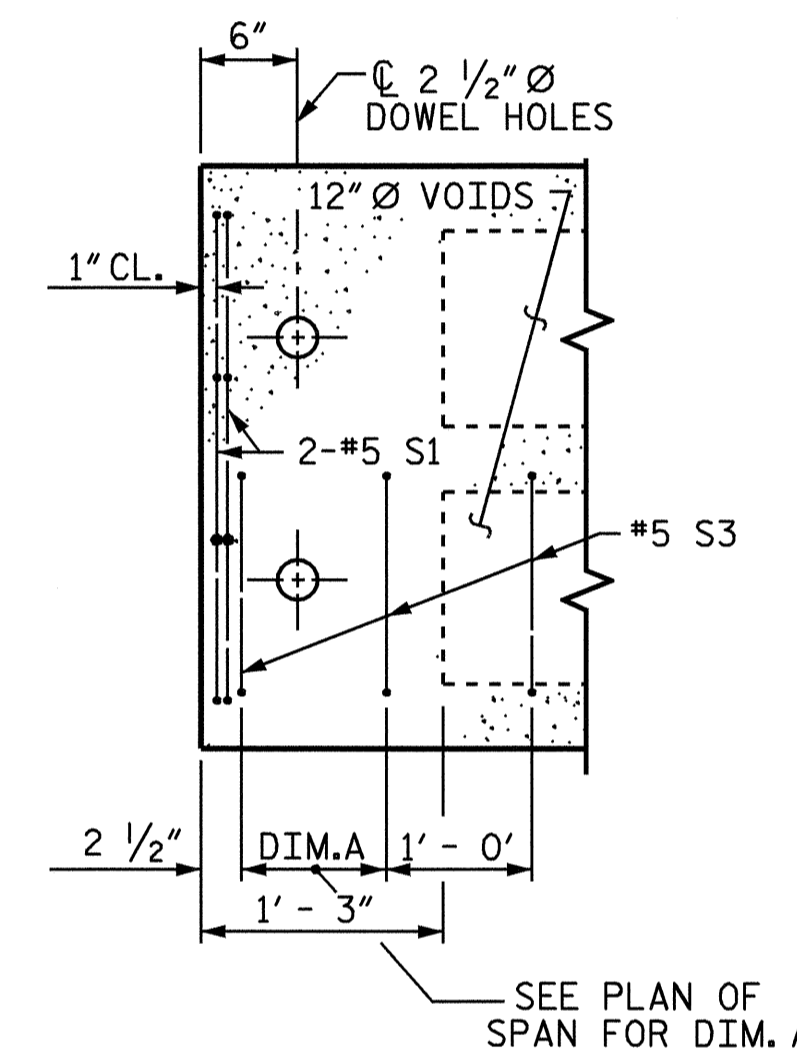

**PART PLAN-EXTERIOR SECTION**

NOTE: EXTERIOR SECTION SHOWN-INTERIOR SECTION SIMILAR EXCEPT OMIT S3 BARS.

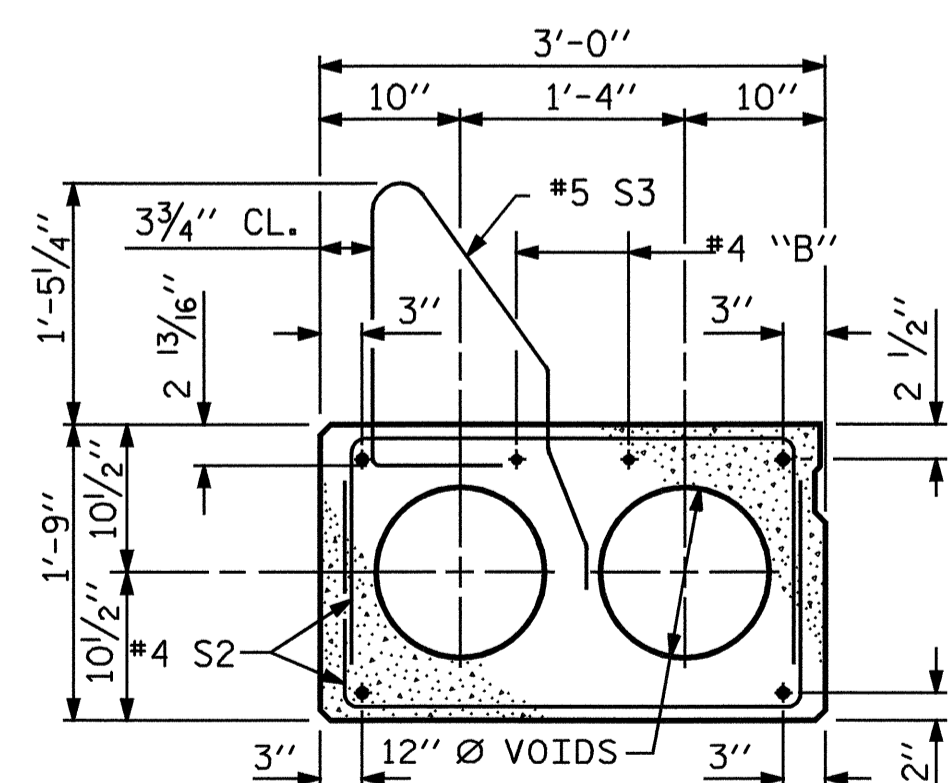

**EXTERIOR SLAB SECTION**

(FOR PRESTRESSED STRAND LAYOUT, SEE INTERIOR SLAB SECTION.)

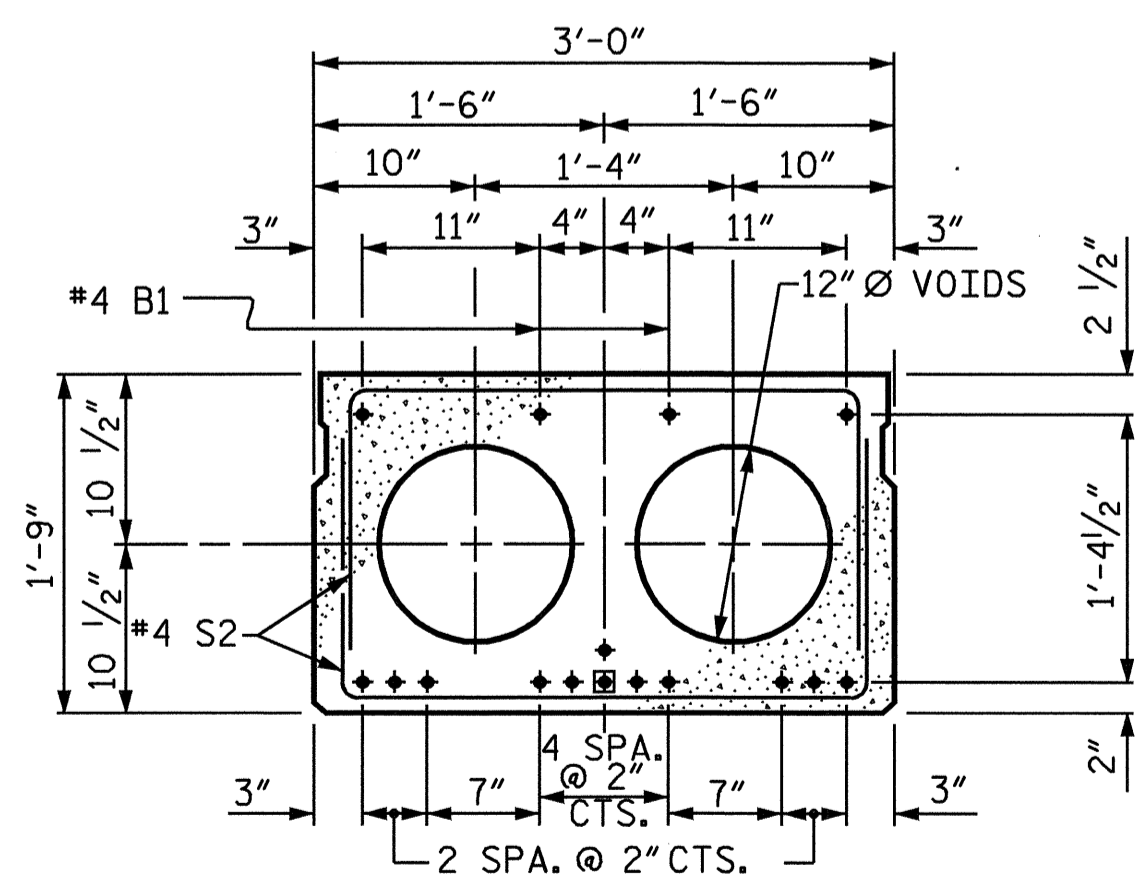

**INTERIOR SLAB SECTION  
1/2" Ø LOW RELAXATION STRAND LAYOUT**

SPAN A & D (14 STRANDS)

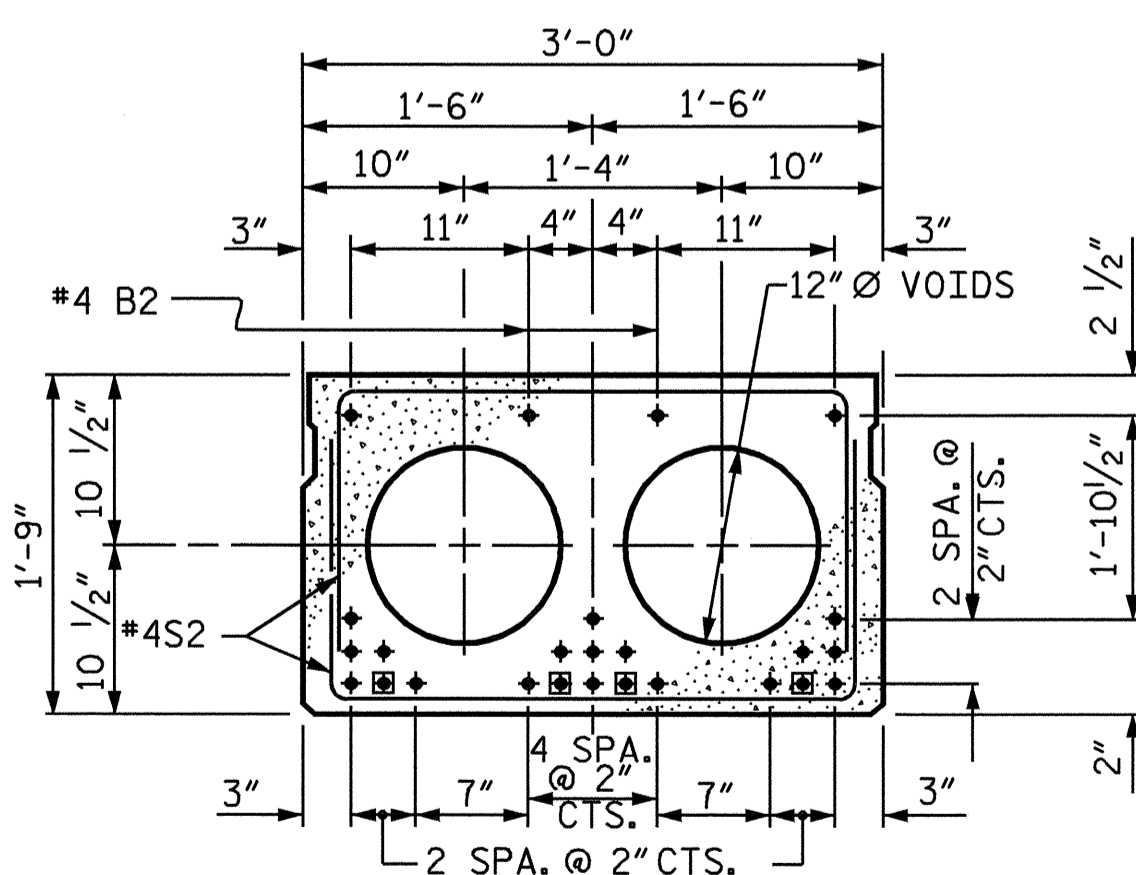

**INTERIOR SLAB SECTION  
1/2" Ø LOW RELAXATION STRAND LAYOUT**

SPAN B & C (23 STRANDS)

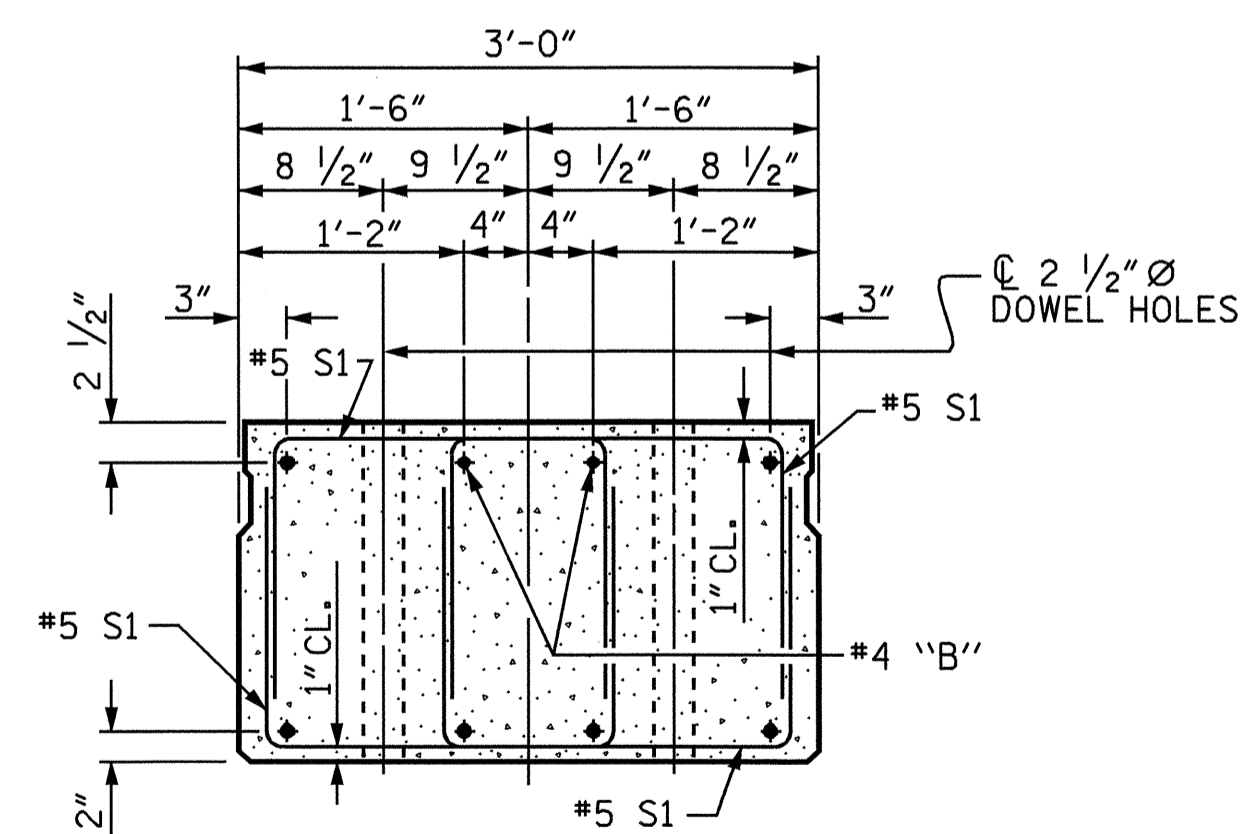

**END ELEVATION**

SHOWING PLACEMENT OF DOUBLE STIRRUPS AND LOCATION OF DOWEL HOLES. (STRAND LAYOUT NOT SHOWN.) INTERIOR SLAB SECTION SHOWN-EXTERIOR SLAB SECTION SIMILAR EXCEPT SHEAR KEY LOCATION.

DRAWN BY: R. G. EMERSON      DATE: 8/03  
CHECKED BY: S. B. WILLIAMS      DATE: 11/03

□ BOND SHALL BE BROKEN ON THESE STRANDS FOR A DISTANCE OF 4'-0" FROM END OF CORED SLAB UNIT, SEE STANDARD SPECIFICATIONS ARTICLE 1078-7.

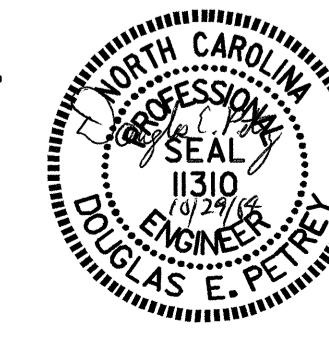

PROJECT NO. B-4270  
SAMPSON COUNTY  
STATION: 14+60.00 -L-

SHEET 1 OF 6

STATE OF NORTH CAROLINA  
DEPARTMENT OF TRANSPORTATION  
RALEIGH  
STANDARD  
3'-0" X 1'-9"  
PRESTRESSED CONCRETE  
CORED SLAB UNIT

REVISIONS						TOTAL SHEETS
NO.	BY:	DATE:	NO.	BY:	DATE:	S-4
1			3			23
2			4			