

NOTE: IF THE APPROACH SLAB IS NOT CONSTRUCTED IMMEDIATELY AFTER THE BACKFILLING OF THE END BENT EXCAVATION, GRADE TO DRAIN TO THE BOTTOM OF THE SLOPE AND PROVIDE EROSION RESISTANT MATERIAL, SUCH AS FIBERGLASS ROVING OR AS DIRECTED BY THE ENGINEER TO PREVENT SOIL EROSION AND TO PROTECT THE AREA ADJACENT TO THE STRUCTURE. THE CONTRACTOR WILL BE REQUIRED TO REMOVE THESE MATERIALS PRIOR TO CONSTRUCTION OF THE APPROACH SLAB.

TEMPORARY DRAINAGE DETAIL

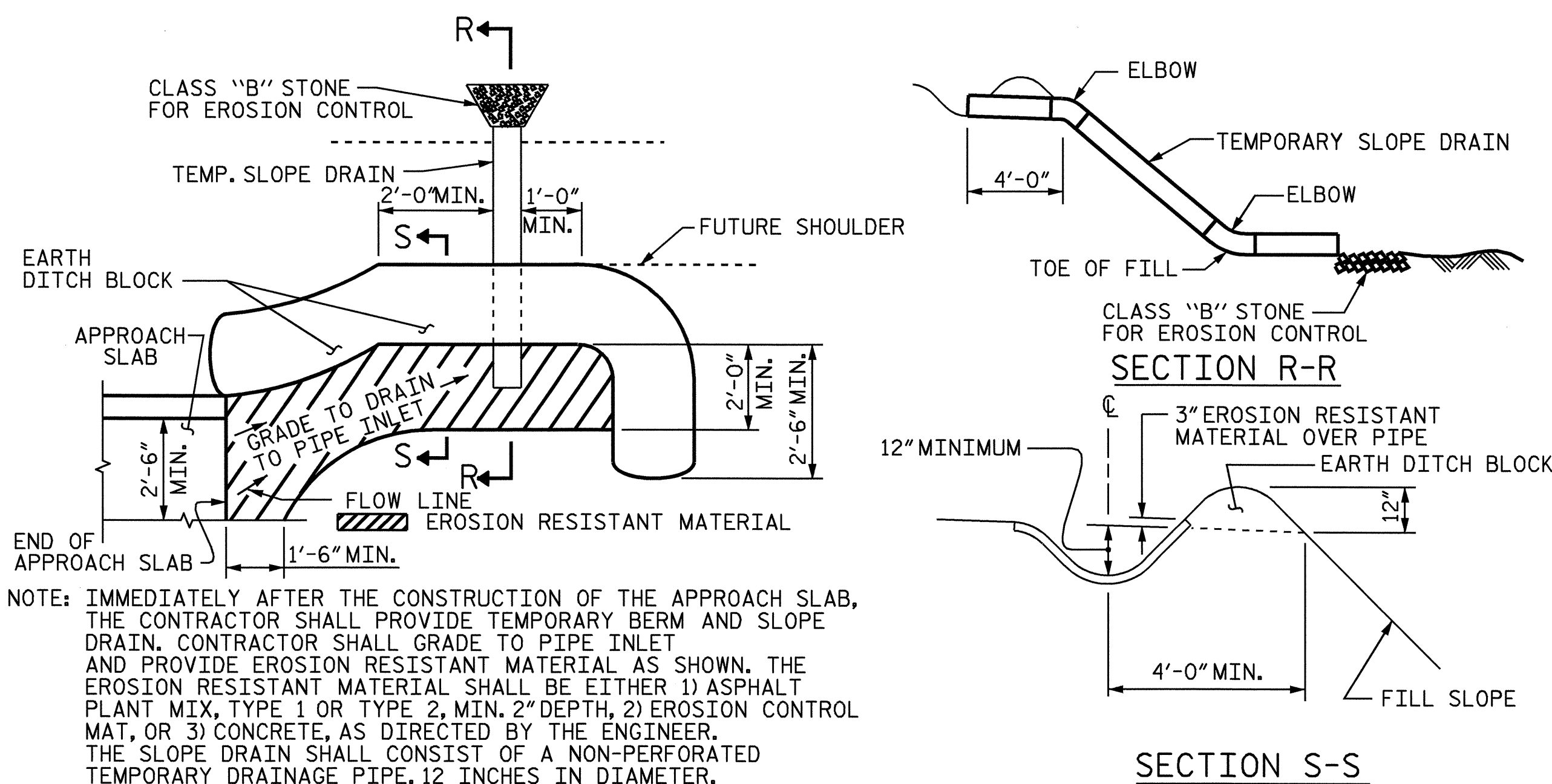

PLAN VIEW

TEMPORARY BERM AND SLOPE DRAIN DETAILS

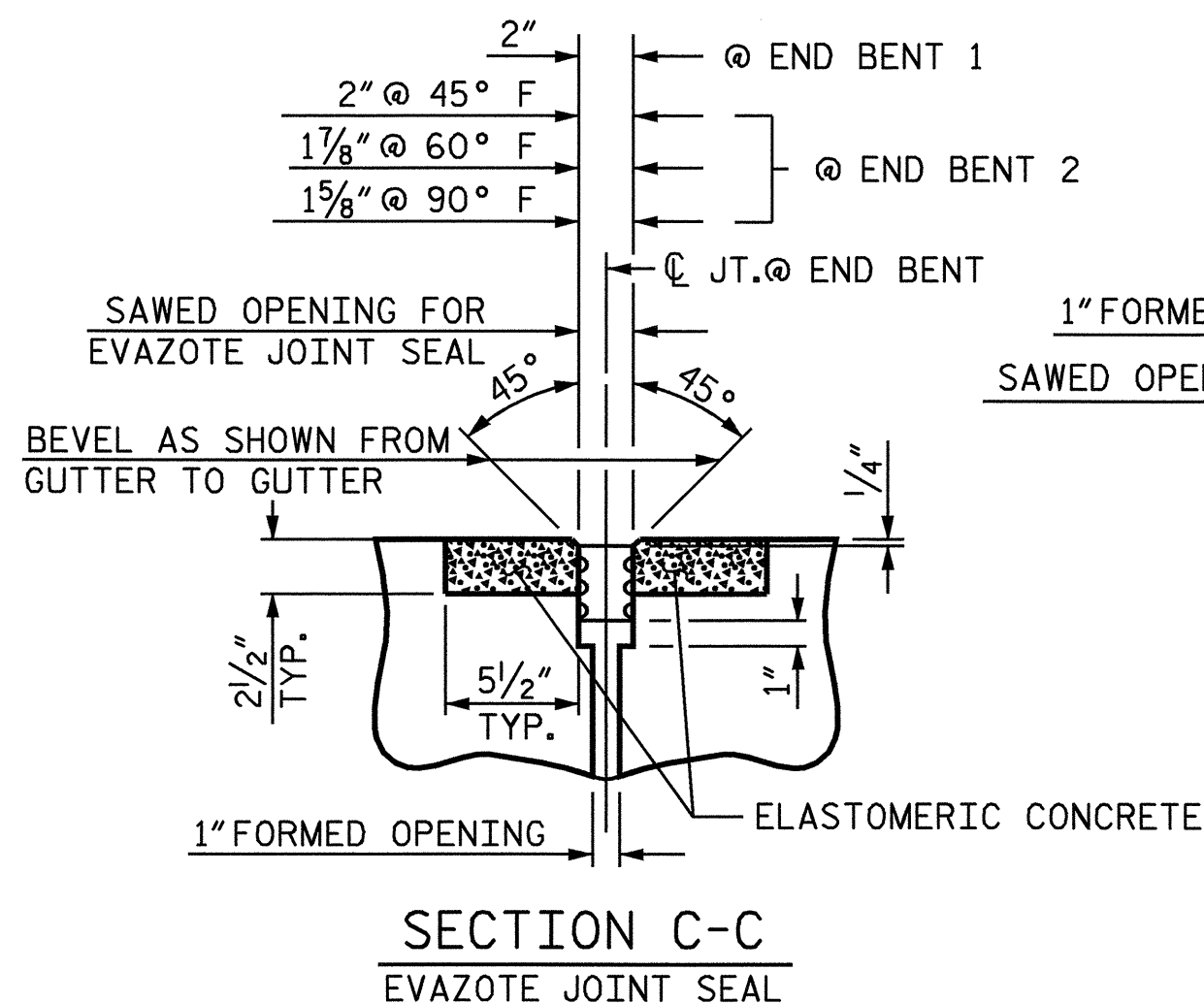

SECTION C-C
EVAZOTE JOINT SEAL

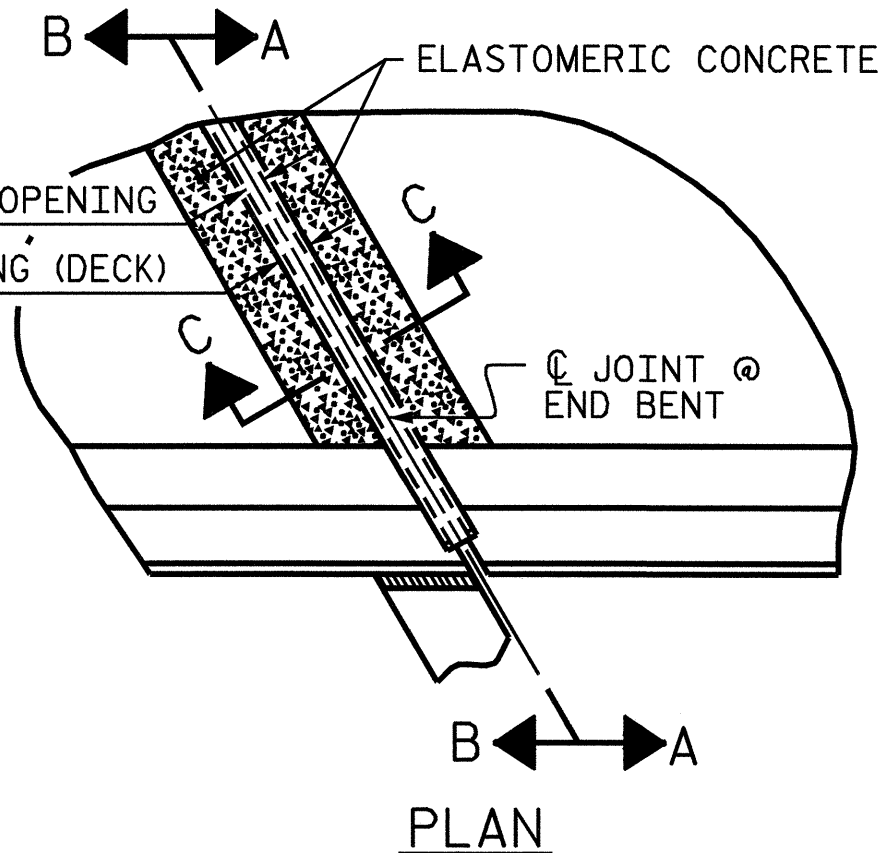

PLAN

SECTION B-B

JOINT SEAL DETAILS @ END BENT

(FOR BARRIER RAIL)

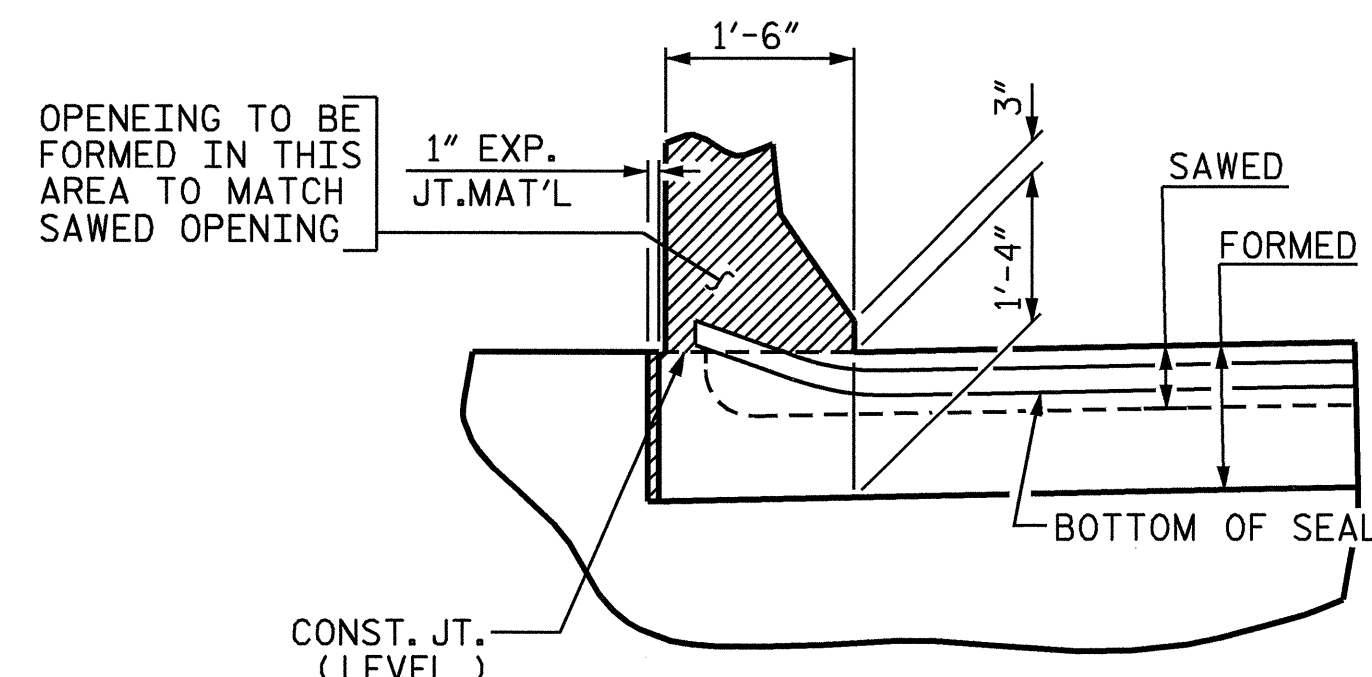

SECTION A-A

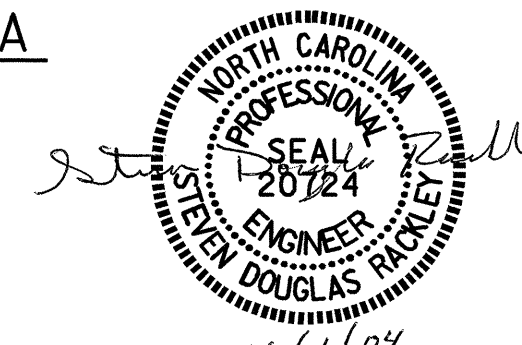

BILL OF MATERIAL FOR ONE APPROACH SLAB (2 REQ'D)

BAR	NO.	SIZE	TYPE	LENGTH	WEIGHT	BAR	NO.	SIZE	TYPE	LENGTH	WEIGHT	BAR	NO.	SIZE	TYPE	LENGTH	WEIGHT	BAR	NO.	SIZE	TYPE	LENGTH	WEIGHT	
*A1	5	#5	STR	38'-8"	202	A203	8	#4	STR	18'-4"	98	*B102	2	#6	STR	27'-2"	82	B220	2	#8	STR	44'-8"	239	
A2	10	#4	STR	20'-3"	135	A204	8	#4	STR	17'-8"	94	*B103	2	#6	STR	27'-6"	83	B221	2	#8	STR	45'-7"	243	
						A205	8	#4	STR	17'-1"	91	*B104	2	#6	STR	28'-6"	86	B222	2	#8	STR	46'-7"	249	
*A101	4	#5	STR	37'-5"	156	A206	8	#4	STR	16'-5"	88	*B105	2	#6	STR	29'-6"	89	B223	2	#8	STR	47'-7"	254	
*A102	4	#5	STR	36'-1"	151	A207	4	#4	STR	29'-8"	79	*B106	2	#6	STR	30'-5"	91	B224	2	#8	STR	48'-6"	259	
*A103	4	#5	STR	34'-10"	145	A208	4	#4	STR	28'-4"	76	*B107	2	#6	STR	31'-5"	94	B225	2	#8	STR	49'-6"	264	
*A104	4	#5	STR	33'-6"	140	A209	4	#4	STR	27'-1"	72	*B108	2	#6	STR	32'-5"	97	B226	2	#8	STR	50'-6"	270	
*A105	4	#5	STR	32'-3"	135	A210	4	#4	STR	25'-9"	69	*B109	2	#6	STR	33'-4"	100	B227	2	#8	STR	51'-6"	275	
*A106	4	#5	STR	30'-11"	129	A211	4	#4	STR	24'-6"	65	*B110	2	#6	STR	34'-4"	103	B228	2	#8	STR	52'-5"	280	
*A107	4	#5	STR	29'-8"	124	A212	4	#4	STR	23'-2"	62	*B111	2	#6	STR	35'-4"	106	B229	2	#8	STR	53'-5"	285	
*A108	4	#5	STR	28'-4"	118	A213	4	#4	STR	21'-11"	59	*B112	2	#6	STR	36'-3"	109	B230	2	#8	STR	54'-5"	291	
*A109	4	#5	STR	27'-1"	113	A214	4	#4	STR	20'-7"	55	*B113	2	#6	STR	37'-3"	112	B231	2	#8	STR	55'-4"	295	
*A110	4	#5	STR	25'-9"	107	A215	4	#4	STR	19'-4"	52	*B114	2	#6	STR	38'-3"	115	B232	2	#8	STR	56'-4"	301	
*A111	4	#5	STR	24'-6"	102	A216	4	#4	STR	18'-0"	48	*B115	2	#6	STR	39'-2"	118	B233	2	#8	STR	57'-4"	306	
*A112	4	#5	STR	23'-2"	97	A217	4	#4	STR	16'-9"	45	*B116	2	#6	STR	40'-2"	121	B234	2	#8	STR	58'-3"	311	
*A113	4	#5	STR	21'-11"	91	A218	4	#4	STR	15'-5"	41	*B117	2	#6	STR	41'-2"	124	B235	2	#8	STR	59'-3"	316	
*A114	4	#5	STR	20'-7"	86	A219	4	#4	STR	14'-2"	38	*B118	2	#6	STR	42'-1"	126	B236	10	#8	STR	33'-5"	892	
*A115	4	#5	STR	19'-4"	81	A220	4	#4	STR	12'-10"	34	*B119	2	#6	STR	43'-1"	129							
*A116	4	#5	STR	18'-0"	75	A221	4	#4	STR	11'-7"	31	*B120	2	#6	STR	44'-1"	132	*G1	2	#5	STR	44'-5"	92	
*A117	4	#5	STR	16'-9"	70	A222	4	#4	STR	10'-3"	27	*B121	2	#6	STR	45'-1"	135	*G2	4	#5	STR	37'-2"	156	
*A118	4	#5	STR	15'-5"	64	A223	4	#4	STR	9'-0"	24	*B122	2	#6	STR	46'-0"	138							
*A119	4	#5	STR	14'-2"	59	A224	4	#4	STR	7'-8"	20	*B123	2	#6	STR	47'-0"	141	*S1	56	#5	STR	3'-3"	190	
*A120	4	#5	STR	12'-10"	54	A225	4	#4	STR	6'-8"	18	*B124	2	#6	STR	48'-0"	144	*S2	40	#5	1	4'-1"	170	
*A121	4	#5	STR	11'-7"	48	A226	4	#4	STR	5'-4"	14	*B125	2	#6	STR	48'-11"	147	*S3	20	#5	2	2'-3"	47	
*A122	4	#5	STR	10'-3"	43	A227	4	#4	STR	4'-1"	11	*B126	2	#6	STR	49'-11"	150	REINFORCING STEEL						11249 LBS
*A123	4	#5	STR	9'-0"	38	A228	4	#4	STR	2'-9"	7	*B127	2	#6	STR	50'-11"	153	EPOXY COATED REINF. STEEL						9243 LBS
*A124	4	#5	STR	7'-8"	32							*B128	2	#6	STR	51'-10"	156	CLASS AA CONCRETE BREAKDOWN						
*A125	4	#5	STR	6'-8"	28	A230	4	#4	STR	19'-9"	53	*B129	2	#6	STR	52'-10"	159	POUR 1 SLAB						65.1 C.Y.
*A126	4	#5	STR	5'-4"	22	A231	4	#4	STR	18'-11"	51	*B130	2	#6	STR	53'-10"	162	POUR 2 RAIL						2.4 C.Y.
*A127	4	#5	STR	4'-1"	17	A232	4	#4	STR	18'-1"	48	*B131	2	#6	STR	54'-9"	164	CLASS AA CONCRETE						67.5 C.Y.
*A128	4	#5	STR	2'-9"	11	A233	4	#4	STR	17'-2"	46	*B132	2	#6	STR	55'-9"	167	ELASTOMERIC CONCRETE						13.8 CU.FT.
						A234	4	#4	STR	16'-4"	44	*B133	2	#6	STR	56'-9"	170	BAR TYPES						
*A130	2	#5	STR	37'-8"	79	A235	2	#4	STR	29'-0"	39	*B134	2	#6	STR	57'-8"	173	1						
*A131	2	#5	STR	34'-11"	73	A236	2	#4	STR	27'-4"	37	*B135	2	#6	STR	58'-8"	176	2						
*A132	2	#5	STR	33'-3"	69	A237	2	#4	STR	25'-7"	34	*B136	10	#6	STR	33'-1"	497	3						
*A133	2	#5	STR	31'-6"	66	A238	2	#4	STR	23'-10"	32													
*A134	2	#5	STR	29'-9"	62	A239	2	#4	STR	21'-11"	29	B200	2	#8	STR	25'-2"	134							
*A135	2	#5	STR	28'-0"	58	A240	2	#4	STR	20'-2"	27	B201	2	#8	STR	26'-2"	140							
*A136	2	#5	STR	26'-4"	55	A241	2	#4	STR	18'-5"	25	B202	2	#8	STR	27'-2"	145							
*A137	2	#5	STR	24'-7"	51	A242	2	#4	STR	16'-8"	22	B203	2	#8	STR	28'-1"	150							
*A138	2	#5	STR	22'-10"	48	A243	2	#4	STR	15'-0"	20	B204	2	#8	STR	29'-1"	155							
*A139	2	#5	STR	20'-11"	44	A244	2	#4	STR	13'-3"	18	B205	2	#8	STR	30'-1"	161							
*A140	2	#5	STR	19'-2"	40	A245	2	#4	STR	11'-6"	15	B206	2	#8	STR	31'-0"	166							
*A141	2	#5	STR	17'-5"	36	A246	2	#4	STR	9'-9"	13	B207	2	#8	STR	32'-0"	171							
*A142	2	#5	STR	15'-8"	33	A247	2	#4	STR	8'-0"	11	B208	2	#8	STR	33'-0"	176							
*A143	2	#5	STR	14'-0"	29	A248	2	#4	STR	6'-4"	8	B209	2	#8	STR	33'-11"	181							
*A144	2	#5	STR	12'-3"	26	A249	2	#4	STR	4'-7"	6	B210	2	#8	STR	34'-11"	186							
*A145	2	#5	STR	10'-6"	22	A250	2	#4	STR	2'-10"	4	B211	2	#8	STR	35'-11"	192							
*A146	2	#5	STR	8'-9"	18							B212	2	#8	STR	36'-10"	197							
*A147	2	#5	STR	7'-0"	15	*B1	7	#5	STR	12'-0"	88	B213	2	#8	STR	37'-10"	202							
*A148	2	#5	STR	5'-4"	11	*B2	1	#5	3	8'-5"	9	B214	2	#8	STR	38'-10"	207							
*A149	2	#5	STR	3'-7"	7	*B3	7	#5	STR	13'-0"	95	B215	2	#8	STR	39'-9"	212							
*A150	2	#5	STR	2'-5"	5	*B4	1	#5	3	6'-7"	7	B216	2	#8	STR	40'-9"	218							
												B217	2	#8	STR	41'-9"	223							
A201	8	#4	STR	19'-7"	105	*B100	2	#6	STR	25'-2"	76	B218	2	#8	STR	42'-8"	228							
A202	8	#4	STR	19'-0"	102	*B101	2	#6	STR	26'-2"	79	B219	2	#8	STR	43'-8"	233							

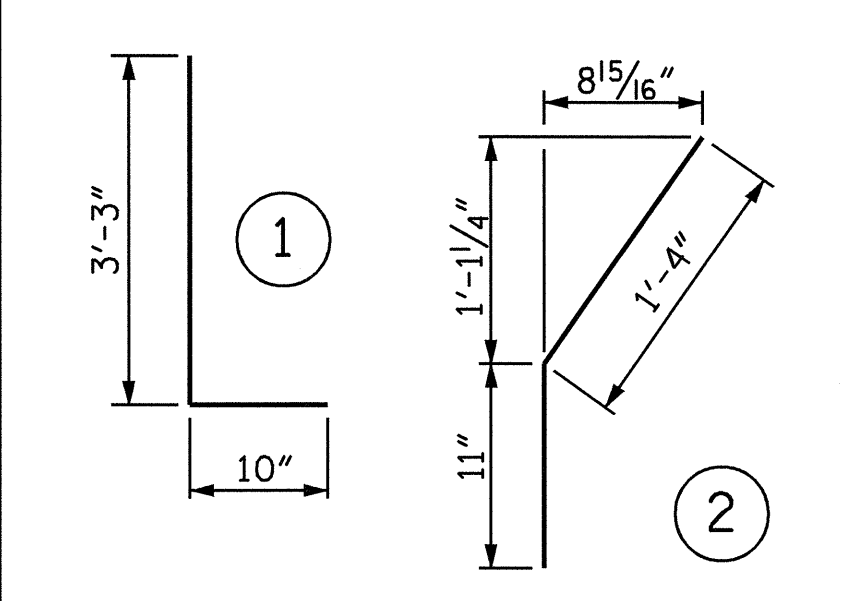

ALL BAR DIMENSIONS ARE OUT TO OUT

PROJECT NO. R-2911D
ROWAN COUNTY
STATION: 231+17.87 -L-
14+25.15 -Y8-
SHEET 4 OF 4

STATE OF NORTH CAROLINA
DEPARTMENT OF TRANSPORTATION
RALEIGH
STANDARD
BRIDGE APPROACH
SLAB DETAILS
(RIGHT LANE)

REVISIONS						SHEET NO.
NO.	BY:	DATE:	NO.	BY:	DATE:	S-54
1			3			TOTAL SHEETS 120
2			4			

DRAWN BY: A. CHAN DATE: 05/11/04
CHECKED BY: A. K. PATEL DATE: 05/14/04