

NOTES

FOR AASHTO M270 GRADE 50W STRUCTURAL STEEL, LEVELING PLATES AND ANCHORAGE PLATES SHALL BE AASHTO M270 GRADE 50W AND SHALL NOT BE GALVANIZED. ANCHOR BOLTS, NUTS AND WASHERS SHALL BE GALVANIZED IN ACCORDANCE WITH THE STANDARD SPECIFICATIONS.

ANCHOR BOLTS SHALL MEET THE REQUIREMENTS OF ASTM A449. NUTS SHALL MEET THE REQUIREMENTS OF AASHTO M291-DH OR AASHTO M292-2H. WASHERS SHALL MEET THE REQUIREMENTS OF AASHTO M293. SHOP DRAWINGS ARE NOT REQUIRED FOR ANCHOR BOLTS, NUTS AND WASHERS. SHOP INSPECTION IS REQUIRED.

ALL SURFACES OF LEVELING PLATES SHALL BE SMOOTH AND STRAIGHT.

WHEN FIELD WELDING THE LEVELING PLATE TO THE GIRDER FLANGE, USE TEMPERATURE INDICATING WAX PENS, OR OTHER SUITABLE MEANS, TO ENSURE THAT THE TEMPERATURE OF THE LEVELING PLATE DOES NOT EXCEED 300°F. TEMPERATURES ABOVE THIS MAY DAMAGE THE ELASTOMER.

AT ALL FIXED POINTS OF SUPPORT AT INTEGRAL END BENT 1 AND 2, TOP NUTS FOR ANCHOR BOLTS ARE TO BE TIGHTENED FINGER TIGHT AND THEN BACKED OFF 1/2 TURN. THE THREAD OF THE NUT AND BOLT SHALL THEN BE BURRED WITH A SHARP POINTED TOOL.

STRUCTURAL PLATE WASHERS SHALL BE AASHTO M270 GRADE 50W.

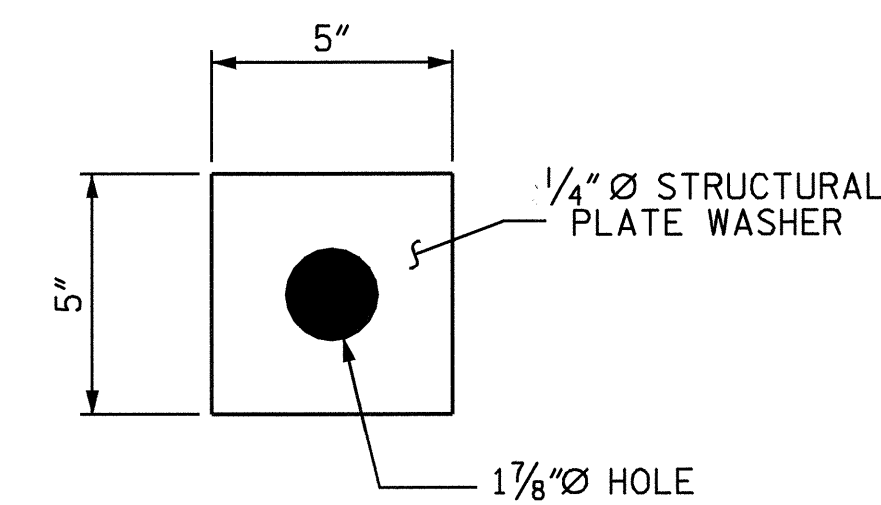
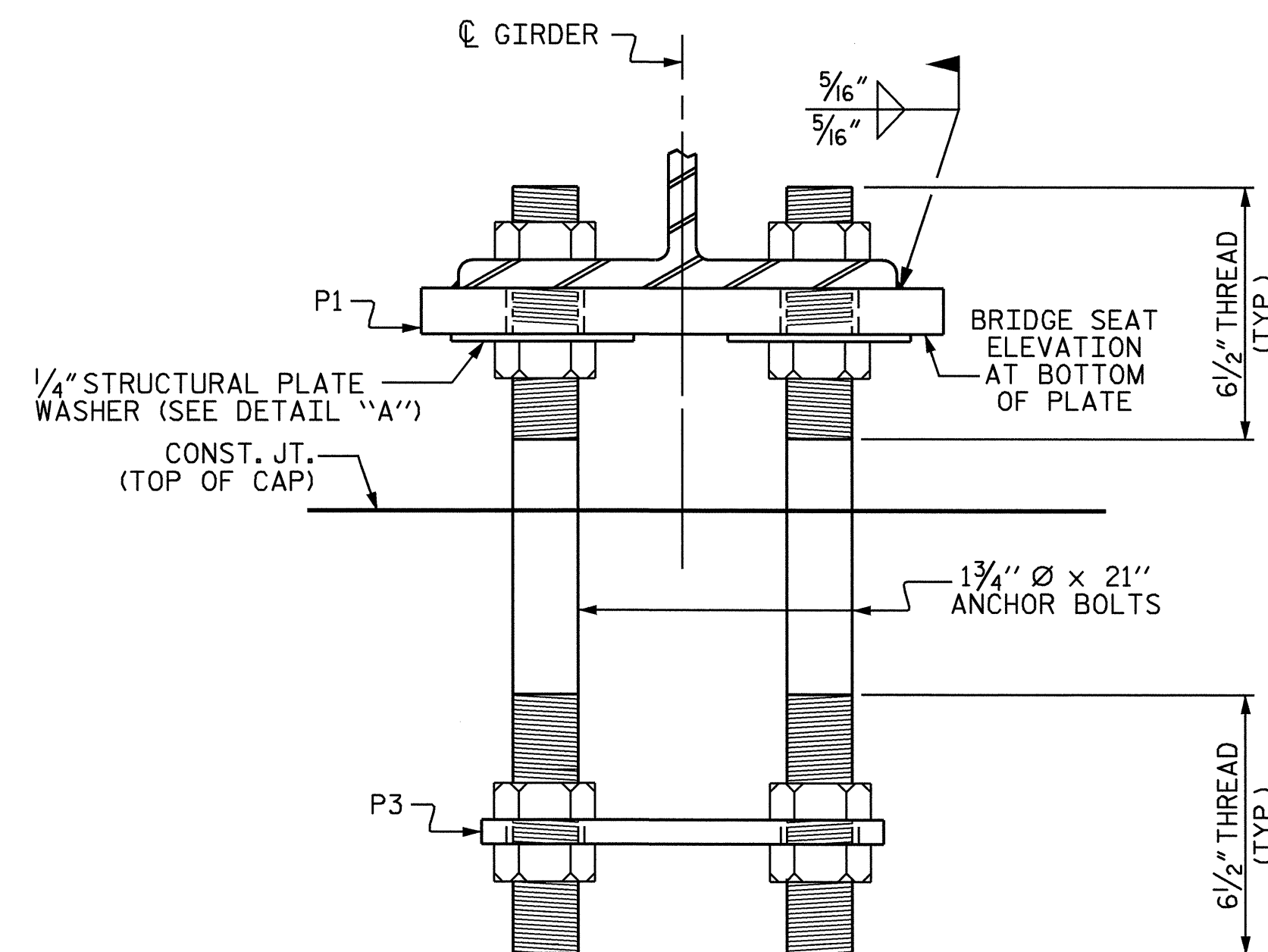

DETAIL "A"

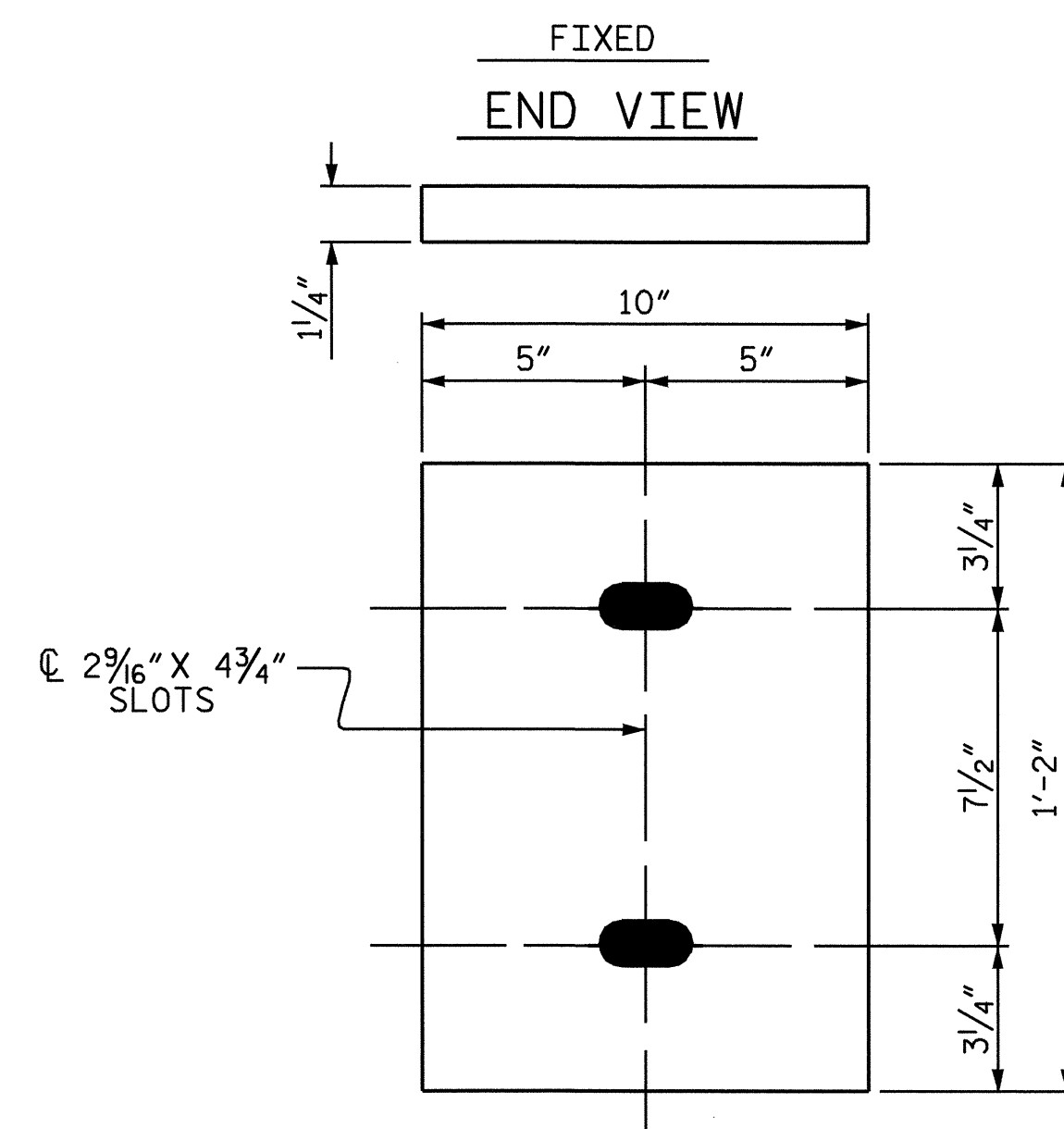

P1
(FIXED)
P1 (10 REQ'D)

LEVELING PLATE DETAILS (P1)

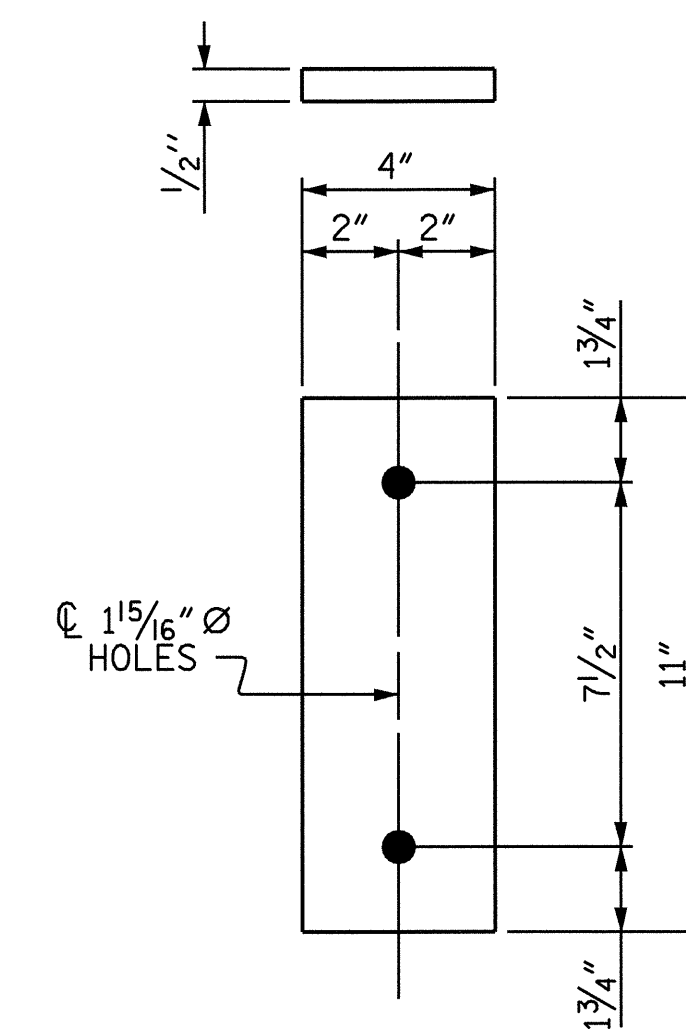

P3
(FIXED)
P3 (10 REQ'D)

ANCHORAGE PLATE (P3)

PROJECT NO. R-2911D
ROWAN COUNTY
 STATION: 304+22.00-L-

STATE OF NORTH CAROLINA
 DEPARTMENT OF TRANSPORTATION
 RALEIGH

LEVELING PLATE
 DETAILS
 (RIGHT LANE)

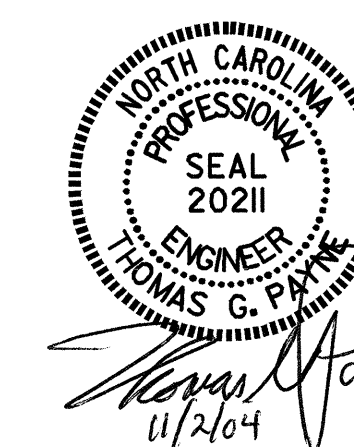

REVISIONS						SHEET NO.	
NO.	BY:	DATE:	NO.	BY:	DATE:	S-101	
1			3			TOTAL SHEETS	120
2			4				

DRAWN BY: S.H. SOCKWELL DATE: 4/04
 CHECKED BY: K.D. LAYNE DATE: 5/04