

EDI MODEL 2010ECL CONFLICT MONITOR

PROGRAMMING DETAIL

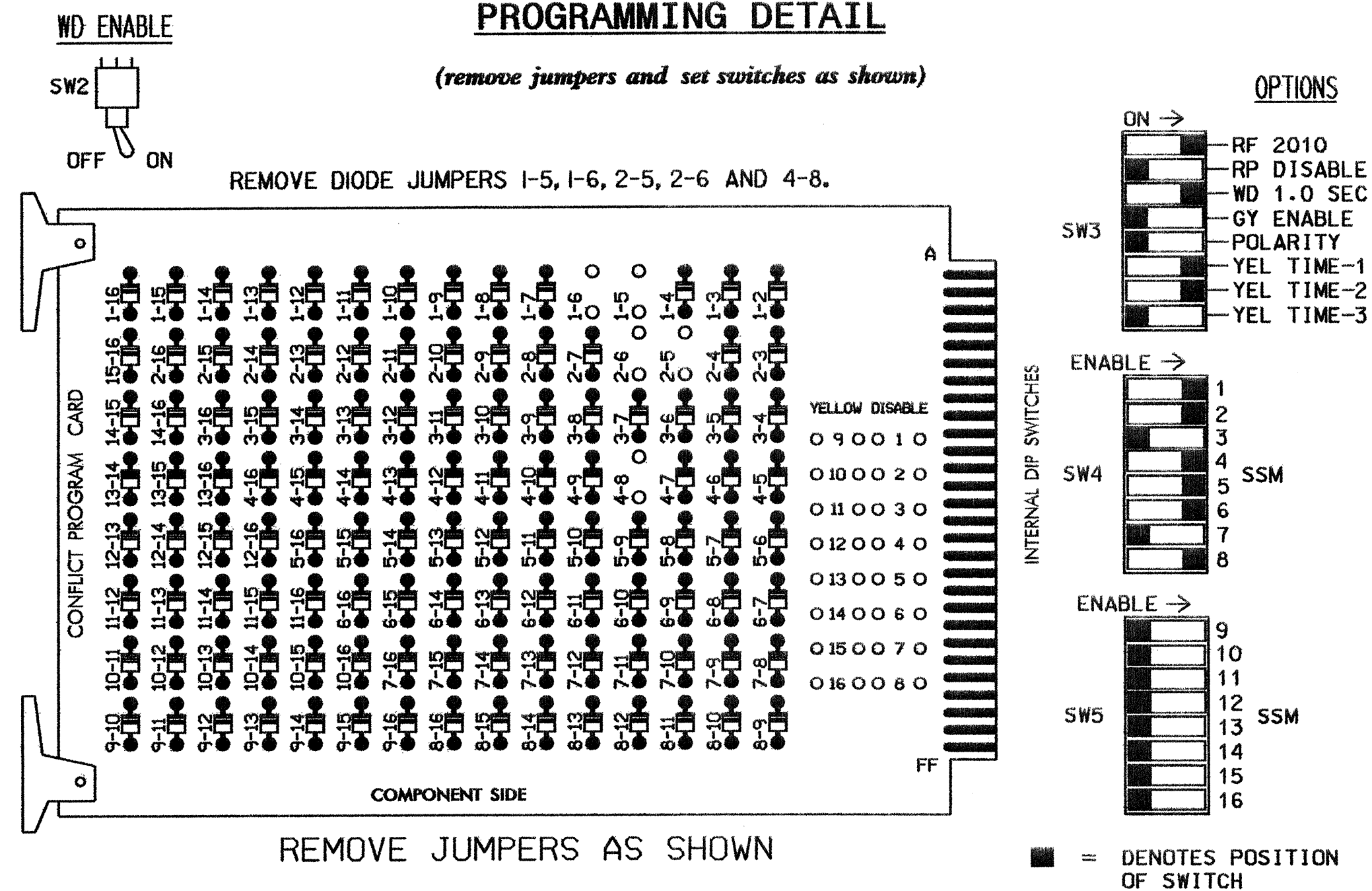

NOTES

- TO PREVENT "FLASH-CONFLICT" PROBLEMS, INSERT RED FLASH PROGRAM BLOCKS FOR ALL UNUSED VEHICLE LOAD SWITCHES IN THE OUTPUT FILE. THE INSTALLER SHALL VERIFY THAT SIGNAL HEADS FLASH IN ACCORDANCE WITH THE SIGNAL PLANS.
- ENSURE THAT RED ENABLE IS ACTIVE AT ALL TIMES DURING NORMAL OPERATION. TO PREVENT RED FAILURES ON UNUSED MONITOR CHANNELS, TIE UNUSED RED MONITOR INPUTS 3,7,9,10, 11,12,13,14,15 & 16 TO LOAD SWITCH AC+ PER THE CABINET MANUFACTURER'S INSTRUCTIONS.
- PROGRAM CONTROLLER TO START UP IN PHASES 2 AND 6 GREEN.
- ENABLE SIMULTANEOUS GAP-OUT FEATURE, ON CONTROLLER UNIT, FOR ALL PHASES.
- PROGRAM PHASES 4 AND 8, ON CONTROLLER UNIT, FOR DUAL ENTRY.

FIELD CONNECTION HOOK-UP CHART

LOAD SWITCH NO.	S1	S2	S2P	S3	S4	S4P	S5	S6	S6P	S7	S8	S8P
PHASE	1	2	2 PED	3	4	4 PED	5	6	6 PED	7	8	8 PED
SIGNAL HEAD NO.	61,82	21,22	NU	NU	41,42	NU	21,42	61,62	NU	NU	81	82,83
GREEN		130			103			136				109
YELLOW		129			102			135				108
RED	*	128			101		*	134				107
RED ARROW												
YELLOW ARROW	126							132				
GREEN ARROW	127							133				

NU = NOT USED
* DENOTES INSTALL LOAD RESISTOR. SEE LOAD RESISTOR INSTALLATION DETAIL THIS PAGE.

EQUIPMENT INFORMATION

CONTROLLER.....CONTRACTOR SUPPLIED 2070L
CABINETCONTRACTOR SUPPLIED 332
SOFTWAREECONOLITE OASIS
CABINET MOUNT.....BASE
OUTPUT FILE POSITIONS...12
LOAD SWITCHES USED.....S1,S2,S4,S5,S6,S8
PHASES USED.....1,2,4,5,6,8
OVERLAPS.....NONE

BACK-UP PROTECTION PROGRAMMING DETAIL

(program controller as shown below)

- FROM MAIN MENU PRESS '2' (PHASE CONTROL), THEN '1' (PHASE CONTROL FUNCTIONS). SCROLL TO THE BOTTOM OF THE MENU AND ENABLE DYNAMIC/BACKUP CONTROL FUNCTIONS 1 AND 2.
- FROM PHASE CONTROL FUNCTIONS MENU PRESS '2' (DYNAMIC/BACKUP CONTROL FUNCTIONS).

DYNAMIC/BACKUP CONTROL FUNCTION #01
OVERLAPS: ABCDEFGHIJKLMNOP
IF OVERLAPS ARE ACTIVE :
OR PHASES: 12345678910111213141516
IF PHASES ARE ON: X
OMIT PHASES : X
CALL PHASES : X

PRESS 'NEXT'

DYNAMIC/BACKUP CONTROL FUNCTION #02
OVERLAPS: ABCDEFGHIJKLMNOP
IF OVERLAPS ARE ACTIVE :
OR PHASES: 12345678910111213141516
IF PHASES ARE ON: X
OMIT PHASES : X
CALL PHASES : X

BACKUP PROTECTION PROGRAMMING COMPLETE

THIS ELECTRICAL DETAIL IS FOR
THE SIGNAL DESIGN: 09-0708T2
DESIGNED: JULY 2004
SEALED: 7/20/04
REVISED:

INPUT FILE POSITION LAYOUT

(front view)

FILE "I"	1	2	3	4	5	6	7	8	9	10	11	12	13	14
U	1A	2A		4A										FS
L	1A	2B		4B										DC ISOLATOR
U	5A	6A		8A	8C									DC ISOLATOR
L	5A	6B		8B	NOT USED									

EX. : 1A, 2A, ETC. = LOOP NO.'S

FS = FLASH SENSE
ST = STOP TIME

INPUT FILE CONNECTION & PROGRAMMING CHART

LOOP NO.	LOOP TERMINAL	INPUT FILE POS.	PIN NO.	INPUT ASSIGNMENT NO.	DETECTOR NO.	NEMA PHASE	CALL	EXTEND	FULL TIME DELAY	STRETCH TIME	DELAY TIME
1A ¹	TB2-5,6	I2U	39	1	2	1	Y	Y			20
	TB2-7,8	I2L	43	5	12	6	Y	Y			
2A	TB2-9,10	I3U	63	25	32	2	Y	Y		2.3	
2B	TB2-11,12	I3L	76	38	42	2	Y	Y			
4A	TB4-9,10	I6U	41	3	4	4	Y	Y			3
4B	TB4-11,12	I6L	45	7	14	4	Y	Y			15
5A ²	TB3-5,6	J2U	40	2	6	5	Y	Y			20
	TB3-7,8	J2L	44	6	16	2	Y	Y			
6A	TB3-9,10	J3U	64	26	36	6	Y	Y		2.3	
6B	TB3-11,12	J3L	77	39	46	6	Y	Y			
8A	TB5-9,10	J6U	42	4	8	8	Y	Y			3
8B	TB5-11,12	J6L	46	8	18	8	Y	Y			
8C	TB7-1,2	J7U	66	28	38	8	Y	Y			15

¹ADD JUMPERS FROM TB2-5 TO TB2-7, AND FROM TB2-6 TO TB2-8.

²ADD JUMPERS FROM TB3-5 TO TB3-7, AND FROM TB3-6 TO TB3-8.

INPUT FILE POSITION LEGEND: J2L

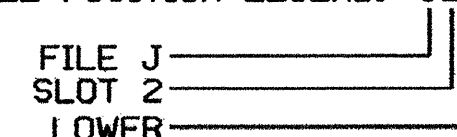

LOAD RESISTOR INSTALLATION DETAIL

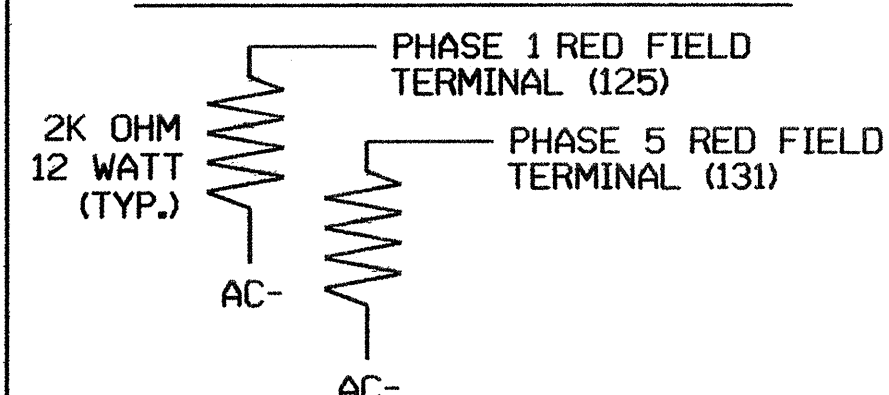

NOTE: THE PURPOSE OF THESE RESISTORS IS TO LOAD THE CHANNEL RED MONITOR INPUTS IN ORDER FOR THE SIGNAL SEQUENCE MONITOR TO USE THE FULL SIGNAL SEQUENCE MONITORING CAPABILITY ON CHANNELS THAT DO NOT USE THE RED DISPLAY IN THE FIELD.

SIGNAL UPGRADE - TEMPORARY 2

ELECTRICAL AND PROGRAMMING DETAILS FOR:

Prepared in the Offices of:
The Engineering and Safety Services Group
STATE OF NORTH CAROLINA
DIVISION OF TRANSPORTATION
Signal Management Section
122 N. McDowell St., Raleigh, NC 27603

US 70 & NC 801
AT
NC 801 & SR 1958

DIVISION 09 ROWAN COUNTY S. OF BARBER

PLAN DATE: JULY 2004 REVIEWED BY: R. Henderson

PREPARED BY: JAMES PETERSON REVIEWED BY:

REVISIONS INIT. DATE

Signature: James Peterson 7/27/04

SIG. INVENTORY NO. 09-0708T2