

**NC 24-27  
MOORE COUNTY**

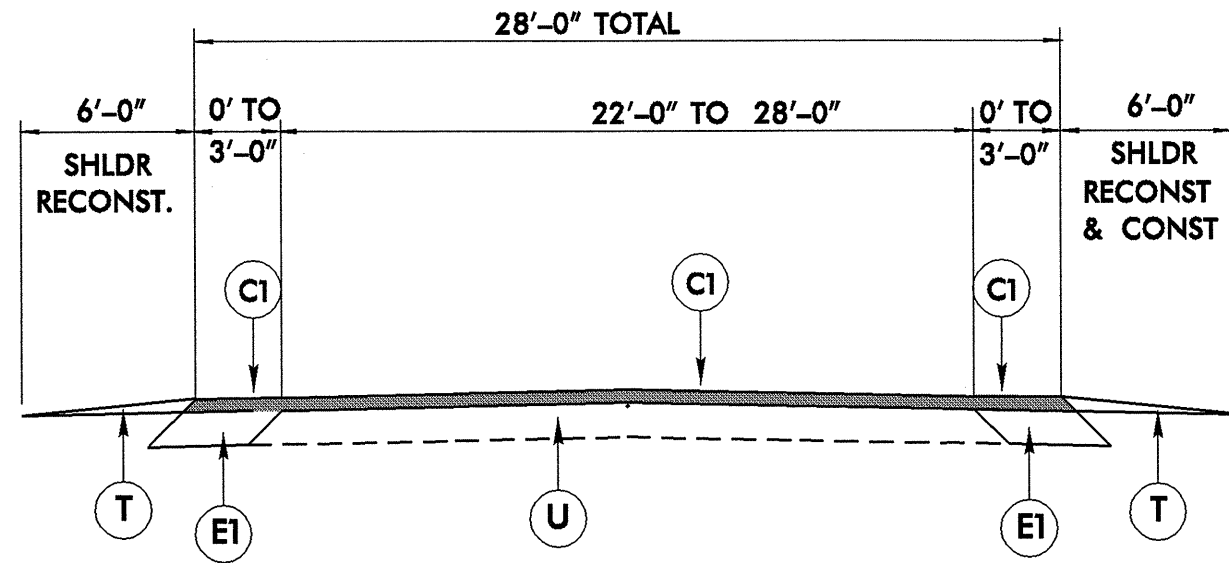

**TYPICAL SECTION NO. 1**

**\*\* NOTE:**

- ON MAP#1 EXISTING ROADWAY IS 28' WIDE CONSISTING OF 22' OF ORIGINAL ROADWAY WITH 3 FT. WIDENING ON EACH SIDE. CONTRACTOR SHALL REMOVE THE WIDEN SECTION OF PAVEMENT AND REPLACE AS SHOWN IN TYPICAL. PAYMENT FOR PAVEMENT REMOVAL WILL BE INCLUDED IN THE LUMP SUM GRADING.

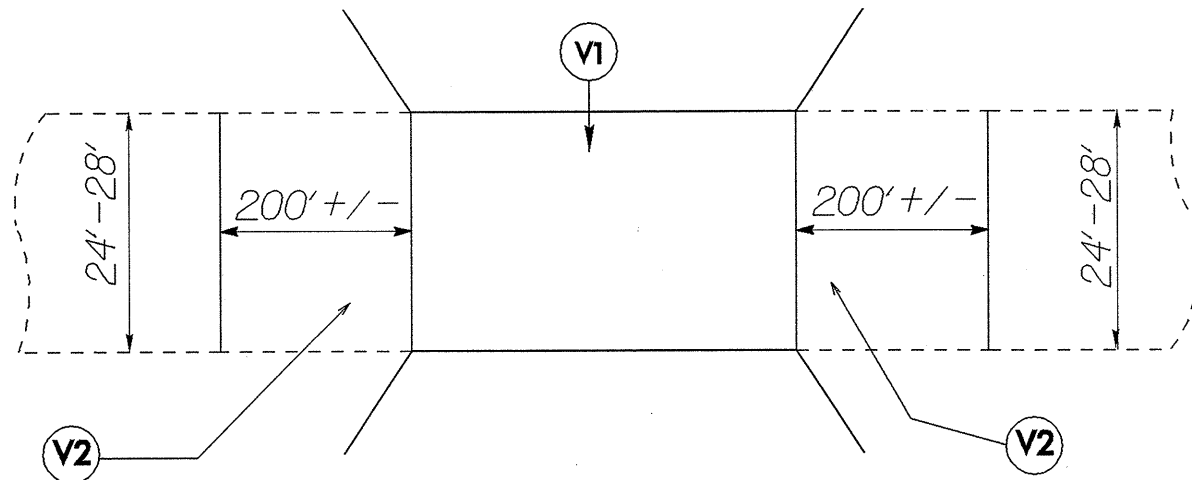

**TYPICAL SECTION NO. 2**

**\*\* NOTE:**

- BRIDGE NOS. 38 & 42 SHALL BE MILLED AT THE DIRECTION OF THE ENGINEER.
- MILLING SHALL BE PAID AT THE UNIT PRICE FOR INCIDENTAL MILLING.

PAVEMENT SCHEDULE	
C1	PROP. APPROX. 3" ASPHALT CONCRETE SURFACE COURSE, TYPE S9.5C, AT AN AVERAGE RATE OF 168 LBS. PER SQ. YD. IN EACH OF TWO LAYERS
E1	PROP. APPROX. 8" ASPHALT CONCRETE BASE COURSE, TYPE B25.0C AT AN AVERAGE RATE OF 458 LBS. PER SQ. YD. IN EACH OF TWO LAYERS
V1	MILLING BITUMINOUS PAVEMENT. 3" TO 6" DEPTH.
V2	MILLING BITUMINOUS PAVEMENT. 0" TO 6" DEPTH.
T	EARTH MATERIAL. (SHOULDER RECONSTRUCTION)
U	EXISTING PAVEMENT.

\*\* NOTE: PAVEMENT EDGE SLOPES ARE 1:1 UNLESS OTHERWISE SHOWN.

\*NOT TO SCALE