

Project Special Provisions
Structures

Table of Contents

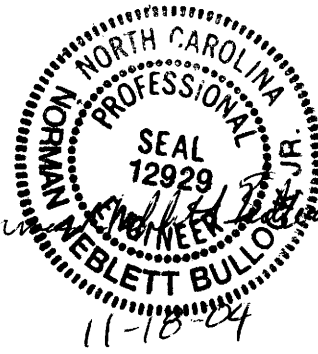

	Page #
Drilled Piers (10-03-02)	1
Crosshole Sonic Logging (7-9-02)	19
Steel Pile Points (10-12-01)	25
Mechanical Butt Splicing For Reinforcing Steel (10-12-01)	26
Minimizing Railroad Flagging Service (10-12-01)	27
Adhesively Anchored Anchor Bolts or Dowels (10-12-01)	28
Evazote Joint Seals (8-13-04)	31
Epoxy Protective Coating (10-12-01)	35
Elastomeric Concrete (10-12-01)	37
Vertical Cracks in Prestressed Concrete Girders Prior to Detensioning (10-12-01)	38
Falsework and Formwork (10-12-01)	39
Submittal of Working Drawings (8-13-04)	44
Construction, Maintenance & Removal of Temporary Access at Stations 12+21.750 -L- & 11+03.000 -Y1- (2-14-04)	50
Metric Structural Steel (10-12-01)	52
Elastomeric Bearings (10-03-02)	53
Unclassified Structure Excavation at Station 12+21.750 -L- & 11+03.000 -Y1- (12-12-02)	53
Prestressed Concrete Members (2-14-04)	53
Fabricated Metal Stay in Place Forms (8-13-04)	54
Concrete Wearing Surface (SPECIAL)	54
Prestressed Concrete Box Beams (SPECIAL)	56
Classic Concrete Bridge Rail (SPECIAL)	61
Footing, Rail & Sidewalk between Structures (SPECIAL)	62
Electrical Conduit System (SPECIAL)	63
Installation of 200 mm DI RJ Water Main at Station 12+21.750 -L- (SPECIAL)	66
Installation of 150 mm DI RJ Water Main at Station 11+03.000 -L- (SPECIAL)	66
Thermal Sprayed Coatings (Metallization) (2-14-04)	69

PROJECT SPECIAL PROVISIONS
STRUCTURES

PROJECT B-2583

MADISON COUNTY

DRILLED PIERS

(10-03-02)

1.0 GENERAL

A. Description

The work in this special provision governs the construction of Drilled Piers, also known as "Drilled Shafts" and "Caissons". Drilled piers are a reinforced concrete section, cast-in-place against in situ, undisturbed material. Drilled piers are a straight shaft type and vertical. Construct drilled piers in accordance with the details and dimensions shown on the plans and the requirements of this special provision.

B. Work Experience

The Contractor/Subcontractor and the Contractor's/Subcontractor's superintendent performing the work described in this special provision is required to have installed drilled piers of both diameter and length similar to those shown on the plans and have a minimum of five years experience with underwater concrete placement prior to the bid date for this project. This work is performed under the supervision of the Contractor's/Subcontractor's superintendent, who is knowledgeable and experienced in the construction of drilled piers using casing and/or slurry. Use equipment that has the capacity to undertake the work and is sufficient to complete the work within the specified contract time. Furnish evidence of experience and expertise that the Contractor/Subcontractor meets the following requirements.

To verify the ability to construct drilled piers for this project, submit a list containing a description of at least two projects completed in the last five years on which those responsible for the drilled pier construction have installed drilled piers of similar size as shown in the plans and with similar excavation techniques anticipated for this project. Include on the list of projects the names and phone numbers of the project owner's representatives who can verify the Contractor/Subcontractor's participation on the project.

C. Construction Sequence Plan

Develop and submit a drilled pier construction sequence plan for all the drilled piers for review and acceptance 30 days prior to beginning construction of the drilled piers. Provide detailed project specific information in the drilled pier construction sequence plan including:

1. Work experience in accordance with Section 1.0, Item B.

2. List and size of proposed equipment including: cranes, kelly bars, drill rigs, vibratory hammers, augers, core barrels, cleanout buckets, airlifts and/or submersible pumps, tremies and/or concrete pumps, casing (diameters, thicknesses and lengths), desanding equipment (for slurry construction), etc.
3. Details of the sequence of drilled pier construction, including the order of drilled pier construction.
4. Details of pier excavation methods.
5. Details of proposed methods to clean the pier excavation bottom.
6. Details of reinforcement placement including support and method to center in the excavation.
7. Details of concrete placement including proposed operational procedures for the concrete tremie or pump; including initial placement, how the tremie or pump is raised during concrete placement and what type of discharge control is proposed to prevent concrete contamination when the tremie or pump is initially placed in the excavation.
8. Details of casing installation and temporary casing removal including order of telescoped casing removal.
9. Required submittals for concrete mix designs.
10. Details of the slurry to be used (if applicable), including: product information, manufacturers mixing instructions, slurry equipment information and how the Contractor proposes to use the slurry. Also, submit a written approval from the bentonite supplier that the water to be used is acceptable.
11. Details on the handling of drilling spoils and slurry overflow including environmental control procedures used to prevent the loss of concrete, slurry and spoils.
12. Details of how the level of slurry is maintained above the highest piezometric pressure head (if applicable).
13. Other information shown in the plans or requested by the Engineer.

The Engineer reviews the drilled pier construction sequence plan for conformance with the plans, specifications and special provisions. Within 15 days of receiving the plan, the Engineer notifies the Contractor of any additional information required and/or changes that are necessary to satisfy the plans, specifications and special provisions. Submit changes for re-evaluation of any unsatisfactory part of the construction sequence plan that is rejected. The Engineer responds to the Contractor within 7 days after receiving the proposed changes.

If any changes in procedure are made during the construction of the drilled piers, inform the Engineer in writing and await approval of the proposed modifications prior to the construction of the remaining drilled piers.

D. Preconstruction Conference

After the drilled pier construction sequence plan is accepted but prior to beginning any drilled pier work, schedule a drilled pier preconstruction conference with the drilling superintendent, the Concrete Supplier, the Resident Engineer including the inspector, the Area Bridge Construction Engineer and the Soils and Foundation Design Engineer to discuss construction and inspection of the drilled piers.

E. Definition of Rock

For the purposes of this special provision, "Rock" is defined as a continuous intact natural material in which the penetration rate with a rock auger is less than 2 inches (50 mm) per 5 minutes of drilling at full crowd force. This definition excludes discontinuous loose natural materials such as boulders and man-made materials such as concrete, steel, timber, etc.

F. Rock Socket

When required by a plan note, provide a minimum penetration into rock as directed by the Engineer.

2.0 EXCAVATION

Perform the excavations required for the drilled piers to the dimensions and elevations shown on the plans or otherwise required by the Engineer, including any miscellaneous grading or excavation to install the drilled pier.

Excavate the drilled pier with a drill rig of adequate capacity. Use a rig that is capable of drilling through soil and non-soil including rock, boulders, timbers, man-made objects and any other materials encountered. Blasting is not permitted to advance the excavation. Blasting for core removal is only permitted when approved by the Engineer. Use a drill rig capable of drilling a minimum of 25% deeper than the deepest drilled pier shown in the plans. Use drilling tools equipped with vents designed to stabilize the hydrostatic pressure above and below the tool during extraction from the excavation. For drilled piers constructed with slurry, monitor the rate at which the drilling tools are inserted and extracted so as to minimize sidewall suction action in the excavation. Drilling below the tip elevations shown on the plans is required if necessary to achieve adequate bearing.

Maintain a drilling log during the drilled pier excavation and provide it to the Engineer. Include in the log information such as top and bottom elevation of each stratum encountered, drilling tools used and drilling time in each stratum and material descriptions of each soil and rock layer.

Drilling spoils consist of all material excavated including water removed from the excavation either by pumping or with augers. Dispose of spoils, with the exception of those containing slurry, as directed by the Engineer and in accordance with Section 802 of the Standard Specifications.

Construct drilled piers at the locations shown on the plans and within the tolerances specified herein. If tolerances are exceeded, provide additional construction as approved by the Engineer to bring the piers within the tolerances specified. Construct the drilled piers such that the axis at the top of the piers is no more than 3 inches (75 mm) in any direction from the position indicated in the plans. Build drilled piers within 1% of the plumb deviation for the total length of the piers. Measure the plumbness of the drilled piers by an accurate procedure, such as an inclinometer on the kelly bar or other approved techniques. Unless a plan note requires the construction joint to be moved below the ground line, construct the finished top of pier elevation between 1 inch (25 mm) above and 3 inches (75 mm) below the top of pier elevation shown on the plans.

When drilling from a barge, use a fixed template that maintains shaft position and alignment during all excavation and concrete placement operations. Floating templates (attached to a barge) are not allowed unless approved by the Engineer.

Stabilize all drilled pier excavations with steel casing and/or bentonite slurry except, as approved by the Engineer, the portions of the excavations in rock as defined by Section 1.0, Item E. Stabilize excavations at all times from the beginning of drilling through concrete placement. Provide casing or slurry in rock if unstable material is anticipated or encountered during drilling. When slurry is used, a partially excavated pier is subject to the time requirements in Section 2.0, Item C, Number 1. When slurry is not used, do not leave a partially excavated pier open overnight unless the excavation is cased to rock.

If the tip of the drilled pier excavation is in rock as defined by Section 1.0, Item E, dewater the excavation to the satisfaction of the Engineer. The minimum diameter of the drilled pier excavation in rock is 2 inches (50 mm) less than the design drilled pier diameter shown on the plans.

If electing to remove a casing and substitute a larger diameter or longer casing through unstable or caving material, either backfill the excavation or stabilize it with a bentonite slurry prior to removing the casing to be replaced. Use other methods, as approved by the Engineer, to control the stability of the excavation during casing replacement.

A. Permanent Steel Casing

Use permanent steel casings as directed by the Engineer and/or a note on the plans. Use permanent casings that are clean smooth non-corrugated watertight steel of ample strength to withstand handling and driving stresses and the pressures imposed by concrete, earth or backfill. Provide permanent casing steel conforming to ASTM A252, Grade 2. The minimum wall thickness of the permanent steel casing depends on the casing diameter and the following requirements.

CASING WALL THICKNESS

Casing Diameter	Minimum Wall Thickness
Less than 42 inches (1066 mm)	3/8 inch (9 mm)
42 inches (1066 mm) to 78 inches (1982 mm)	1/2 inch (12 mm)
Greater than 78 inches (1982 mm)	5/8 inch (16 mm)

Provide permanent casings with an outside diameter not less than specified size of the drilled pier. If approved by the Engineer, a permanent casing larger in diameter than the drilled pier design diameter is permitted. No payment will be made for additional construction materials or other costs associated with a request for a larger casing diameter. Extend the permanent casings from the top of pier elevation or top of permanent casing elevation if shown on the plans to a depth not greater than the permanent casing tip elevation shown on the plans. If electing to extend the permanent steel casing below the permanent casing tip elevation, get prior approval from the Engineer and provide additional drilled pier length if required. No payment will be made for the additional drilled pier length and casing unless the previously approved extension is necessary for dewatering purposes. Place all permanent casings in contact with undisturbed material. Install permanent casing in one continuous unit. If splices are necessary for the casing, use an approved method of splicing. Splices are considered incidental and no additional compensation will be allowed if approved.

Remove any portion of the permanent steel casing that extends above the top of the drilled pier after the drilled pier concrete has achieved a compressive strength of 4500 psi (31.0 MPa). The cost of casing removal will be considered incidental to the cost of the permanent steel casing.

B. Temporary Steel Casing

Provide temporary casing to stabilize drilled pier excavations, protect personnel and prevent caving or sloughing, that is clean smooth non-corrugated watertight steel of ample strength to withstand handling and driving stresses and the pressures imposed by concrete, earth or backfill.

Use temporary steel casings with an outside diameter not less than the specified size of the piers, except for casing to protect inspection personnel. Temporary steel casings are subjected to the same minimum wall thickness requirement as permanent steel casings as shown in Section 2.0, Item A.

Temporary steel casings that become bound or fouled during pier construction and cannot be practically removed constitute a defect in the drilled pier. Improve such defective shafts to the satisfaction of the Engineer by removing the shaft concrete and extending the shaft deeper, providing a replacement shaft, or other acceptable means. Complete all corrective measures including redesign as a result of defective shafts to the satisfaction of the Engineer without additional compensation or an extension of the completion date of the project.

C. Slurry

When slurry use is not noted on the plans, slurry construction is an option.

Use slurry composed of bentonite having a mineral grain size that remains in suspension and sufficient viscosity and gel characteristics to transport excavated material to a suitable screening system to minimize or eliminate bottom sedimentation. Provide material used to make the suspension with a percentage and specific gravity sufficient to maintain the stability of the excavation and allow for proper concrete placement.

When slurry is used and permanent steel casing is not required, use temporary casing a minimum of 10 feet (3 m) long at the top of the excavation. Maintain the top of the temporary casing a minimum of 1 foot (300 mm) above the ground surface surrounding the casing. This temporary casing is also subject to the minimum wall thickness as required for permanent steel casing as shown in Section 2.0, Item A.

Maintain the slurry in the pier excavation at a level not less than 5 feet (1.5 m) or the drilled pier diameter (whichever is greater) above the highest piezometric pressure head along the depth of the pier. It is anticipated that the highest piezometric pressure head is the static water elevation or the groundwater elevation. However, the Contractor is responsible for determining the highest piezometric pressure head. The use of steel casing to maintain the required slurry level is permitted; however, in accordance with the basis of payment for permanent steel casing, no payment will be made for casing that is cut off. If the slurry level in the excavation suddenly changes or cannot be practically maintained, or the slurry construction method does not produce the desired result, stop the pier construction until an alternate construction procedure is approved by the Engineer.

Thoroughly premix the bentonite slurry with clean, fresh water. Have a sample of the water used on the project tested by an independent laboratory, at no additional cost to the Department, to verify that it is suitable for use with the bentonite slurry. Submit written approval from the bentonite supplier that the water to be used is acceptable. Allow 24 hours for hydration of the slurry, prior to introduction into the pier excavation. Slurry tanks of adequate capacity are required for slurry circulation, storage and treatment. Excavated slurry pits are not allowed in lieu of slurry tanks without prior approval from the Engineer. Take all steps necessary to prevent the slurry from "setting up" in the drilled pier. Such methods include, but are not limited to: agitation, circulation and/or adjusting the properties of the slurry. Provide desanding equipment as necessary to achieve a slurry sand content of 2% or less by volume prior to placement of the reinforcement steel.

1. Time

Adjust the excavation operations so that the maximum time the slurry is in contact with the sidewalls of the uncased portions of the drilled pier excavation (from time of drilling to completing concrete placement) does not exceed 24 hours. Also, agitate the slurry in the drilled pier excavations a minimum of every 4 hours. Do not allow an excavated slurry shaft below the steel casing to go unagitated overnight. Do not work on more than two drilled piers per drill rig below the steel casing at any time.

If the 24 hour time limit is exceeded, overream the drilled pier excavation beneath the steel casing a minimum of 1 inch (25 mm) and a maximum of 3 inches (75 mm), or as required by the Engineer, prior to performing other operations in the excavation. Overream with a grooving tool, overreaming bucket or other approved equipment at a minimum spacing of 12 inches (300 mm). The Contractor bears all costs associated with both overreaming and additional shaft concrete placement at no additional cost to the Department.

If concrete placement is not completed within three days of beginning drilling, enlarge the design drilled pier diameter by a minimum of 6 inches (150 mm), or as required by the Engineer, the entire length of the pier at no additional cost to the Department. Enlarging the drilled pier includes replacing the steel casing with steel casing the same size to which the drilled pier is enlarged at no additional cost to the Department.

2. Sampling

Take all slurry samples using an approved sampling tool. Test slurry samples to determine density, viscosity and pH to establish an acceptable working pattern during slurry use. Test a minimum of four samples during each 8 hours of slurry use for each drilled pier. Take the first sample for the first 8 hours from the slurry tank prior to introduction into the pier excavation. Take the remaining samples from the bottom of the drilled pier excavation. When the test results are acceptable and consistent, a decrease in the testing frequency to one sample per 4 hours of slurry use is permitted.

Prior to placing the reinforcing steel in any drilled pier excavation, extract slurry samples from the bottom of each pier excavation and at intervals not exceeding 10 feet (3 m) up the pier, until two consecutive samples produce acceptable values for density, viscosity, pH and sand content.

3. Testing

Have a qualified Engineer or technician, approved by the Engineer, conduct control tests to determine density, viscosity and pH. Use suitable apparatus for the control tests. The following table shows the acceptable range of values for those physical properties:

BENTONITE SLURRY Sodium Montmorillonite (Commercial Bentonite) Acceptable Range of Values			
Property (units)	At Time of Slurry Introduction	In Hole at Time of Drilling	Test Method
Density, pcf (kg/m ³)	64.3 – 69.1* (1030-1107*)	64.3 – 75.0* (1030-1201*)	Density Balance
Viscosity, sec./quart (sec./0.95 liters)	28 – 45	28 – 45	Marsh Cone
pH	8 – 11	8 – 11	pH paper pH meter
* Increase the density by 2 pcf (32 kg/m ³) in saltwater.			
Notes:			
1. Perform tests when the slurry temperature is above 40°F (4.4°C).			
2. The maximum sand content is 2% by volume at any point in the borehole prior to placement of the reinforcement steel as determined by the American Petroleum Institute sand content base.			
3. When field conditions warrant, an adjustment to the limits and test methods in the above table is permitted only after a successful test hole demonstration. Obtain the Engineer's written approval before use.			

When any slurry samples are found to be unacceptable, take whatever action is necessary to bring the bentonite slurry within specification requirements. Do not place reinforcement steel until resampling and testing produce acceptable results.

Generate reports of all tests required above, have them signed by an authorized representative, and submit them to the Engineer upon completion of each drilled pier. Representatives of the Department reserve the right to perform comparison tests as determined necessary during bentonite slurry operations.

4. Slurry Disposal

Comply with all applicable local, state and federal regulations, as well as with the environmental permits of the project when disposing of excavated materials contaminated with slurry. Keep all excavated materials, spoils from the desanding unit and slurry out of the water and contain them at all times. The cost of the containment, removal and disposal of excavated materials contaminated with slurry, as well as the slurry itself, is incidental to the cost of constructing the drilled piers.

3.0 CLEANING

Excavate the bottom of the drilled pier to a level plane or stepped with a maximum step height of 12 inches (300 mm). Regardless of construction methods used, clean the bottom of the excavation of loose material using a technique approved by the Engineer. When the drilled pier excavation can not be dewatered and is not hand cleaned, clean the bottom of the excavation with a cleanout bucket and an airlift or submersible pump.

4.0 INSPECTION METHODS AND REQUIREMENTS

After the drilled pier excavation is complete and immediately prior to placement of the reinforcing steel and concrete, demonstrate the proper condition of the drilled pier excavation to the Engineer for verification. Provide bosun chairs, gas meters, safety equipment, lights, mirrors, weighted tape measures, steel probes, personnel and all assistance required for the Engineer to inspect the drilled pier excavations.

A. Bearing Capacity

One or more of the following tests are used to verify the conditions and continuity of the bearing material prior to placement of the reinforcing steel. If the required tip bearing capacity is not satisfied, then increase the drilled pier length as determined by the Engineer. Payment for the additional length of the drilled pier to achieve adequate bearing will be made per the drilled pier pay items.

1. Visual Inspection

The tip bearing of the drilled pier excavation is inspected either by entering the excavation or visually from the top of the excavation as directed by the Engineer.

2. Test Hole

If the tip of the drilled pier excavation is in rock as defined by Section 1.0, Item E, drill one or more 1½ inch (38 mm) diameter test holes in each drilled pier to a depth at least 6 feet (1.83 m) below the tip elevation.

3. Standard Penetration Test (SPT)

When noted on the plans that a SPT is required, drive a split barrel sampler a minimum of 18 inches (450 mm) below the drilled pier tip elevation or to refusal in accordance with ASTM D1586. Complete the SPT using NW rods through casing or another stabilizing method as approved by the Engineer. Extend the SPT rods from the top of the drilled pier excavation to the drilled pier tip elevation. Firmly support the SPT casing at the top of the drilled pier excavation and rest it on the bottom of the excavation. Conduct the SPT a minimum of 12 inches (300 mm) away from the sidewalls of the excavation and be sure not to scrape the sidewalls of the excavation while inserting or withdrawing the SPT equipment. Have the SPT device on-site prior to reaching the drilled pier tip elevation. Report the number of blows needed to drive the split barrel sampler and a description of the recovered soil sample to the Engineer. The Engineer determines the number of blows required for bearing.

B. Bottom Cleanliness

One or more of the following inspection procedures are used to check the cleanliness of the pier excavation bottom prior to placement of the reinforcement steel and concrete.

The pier excavation bottom is considered clean if a minimum of 50% of the bottom area has less than ½ inch (13 mm) of sediment and no portion of the bottom area has more than 1½ inches (38 mm) of sediment as determined by the Engineer.

1. Visual Inspection

The cleanliness of the drilled pier excavation bottom is observed either by entering the excavation or from the top of the excavation as directed by the Engineer.

2. Steel Probe

If the excavation is not dewatered or if the Engineer requires it, lower a steel probe to the bottom of the drilled pier excavation to ensure that cleaning has been satisfactorily completed. Supply a steel probe that is 2 feet (0.6 m) long with a flat tip on the sounding end, weighs approximately 9 pounds (#10 rebar) (4 kg, #32 rebar) and is suspended from the opposite end with a non-stretch cable.

3. Shaft Inspection Device (SID)

When noted on the plans, the SID is used to take sediment measurements and observe the bottom conditions of the drilled pier excavation at a minimum of five locations selected by the Engineer. The SID is a remotely operated camera capable of observing bottom conditions and measuring sediment underwater and slurry. Each SID inspection (including all 5 locations) takes approximately 1 hour after the equipment has been set up. The Engineer provides the SID and the personnel to operate the device. Notify the Engineer a minimum of 2 days prior to beginning the

drilled pier excavation so the Engineer can arrange for the transportation of the SID to the site and the personnel to perform the inspections. SID inspections are required until the cleanliness of the drilled pier excavation bottom is acceptable in accordance with Section 4.0, Item B of this special provision. Do not conduct operations that interfere with the SID inspections as directed by the Engineer. Remove all cleaning and drilling equipment from the drilled pier excavation during any SID inspection. Provide a working area large enough for the SID equipment, within the reach of the cabling supplied, and within clear sight distance of the drilled pier excavation, as directed by the Engineer. Assist the Engineer in the transportation and handling of the SID and all the associated equipment and in supporting the electric hoist and/or hoisting tripod for the SID, as directed by the Engineer. Provide a safe and secure storage area for the SID and all the associated equipment while it is located unattended on the project site. If any of the SID equipment is damaged, lost or stolen due to the Contractor's negligence, then replace the equipment at no additional cost to the Department. Provide replacement equipment that exactly matches the damaged, lost or stolen equipment as directed by the Engineer. All costs involved with the initial SID inspection of each drilled pier excavation will be made per the SID pay item. No additional payment will be made for subsequent or repeated SID inspections of the same drilled pier excavation. Claims against the Department for either lost time or actual expense of any SID inspections that do not find the cleanliness of the drilled pier excavation bottom in compliance with this special provision are not permitted.

5.0 REINFORCING STEEL

Completely assemble a cage of reinforcing steel, consisting of longitudinal and spiral bars and place it in the drilled pier excavation as a unit immediately after the proper condition of the excavation is demonstrated to the Engineer. When concrete placement does not follow immediately after cage placement, remove the steel from the pier excavation unless the Engineer directs otherwise. If the cage is removed, recheck pier excavation cleanliness in accordance with this special provision prior to reinstallation of the cage.

If the drilled pier excavation is cased down to rock, immediate placement of the reinforcing steel and the concrete is not required. If electing to delay placement of the reinforcing steel and concrete due to the presence of rock, recheck the excavation for proper cleanliness immediately prior to placement of the reinforcing steel.

A. Construction, Placement, Support and Alignment

If it is determined in the field that the drilled pier must be longer, adequate reinforcement is required in the extended length as directed by the Engineer. Lift the cage so racking and cage distortion does not occur. Keep the cage plumb during concrete operations and casing extraction. Check the position of the cage before and after placing the concrete. Position the splice length of the drilled pier cage so that the column or footing has the minimum concrete cover shown on the plans.

Securely cross-tie the vertical and spiral reinforcement at each intersection with double wire. Support or hold down the cage so that the vertical displacement during concrete placement and casing extraction does not exceed 6 inches (150 mm).

B. Bolsters, Blocks and Spacers

Do not set the cage on the bottom of the drilled pier excavation. Place plastic bolsters under each vertical reinforcing bar. If required by the Engineer, provide concrete blocks instead of plastic bolsters to limit rebar cage settlement. Place blocks under each vertical rebar that have a 4 inch (100 mm) minimum diameter and that have a depression to receive the vertical reinforcing bar. Ensure that the blocks are tall enough to raise the rebar cage off the bottom of the drilled pier excavation a minimum of 3 inches (75 mm).

In order to ensure a minimum of 4 inches (100 mm) of concrete cover and achieve concentric spacing of the cage within the pier, tie plastic spacer wheels, subject to the Engineer's approval, at five points around the cage perimeter. Use spacer wheels that provide a minimum of 4 inches (100 mm) "blocking" from the outside face of the spiral bars to the outermost surface of the drilled pier except in rock as defined by Section 1.0, Item E. Use spacer wheels in the rock zone that provide a minimum of 2 inches (50 mm) "blocking". Tie spacer wheels that snap together with wire and allow them to rotate. Use spacer wheels that span at least two adjacent vertical bars. Start placing spacer wheels at the bottom of the cage and continue up along its length at maximum 10 foot (3 m) intervals. At the Engineer's direction, supply additional peripheral spacer wheels and closer intervals if necessary.

6.0 CONCRETE

Begin concrete placement immediately after inserting reinforcing steel into the drilled pier excavation. Prior to placing concrete, assure the Engineer that sufficient quantities of concrete are available and that sufficient transportation is committed to the project to deliver the concrete within the time frame set forth within this special provision.

A. Concrete Mix

Provide the mix design for Drilled Pier Concrete for approval and, except as modified herein, meeting the requirements of Section 1000 of the Standard Specifications.

Designate the concrete as Drilled Pier Concrete with a minimum compressive strength of 4500 psi (31.0 MPa) at 28 days. Make certain the cementitious material content complies with one of the following options:

- Provide a minimum cement content of 640 lbs/yd³ (380 kg/m³) and a maximum cement content of 800 lbs/yd³ (475 kg/m³); however, if the alkali content of the cement exceeds 0.4%, reduce the cement content by 20% and replace it with fly ash at the rate of 1.2 lb (1.2 kg) of fly ash per lb (kg) of cement removed.

- If Type IP blended cement is used, use a minimum of 665 lbs/yd³ (395 kg/m³) Type IP blended cement and a maximum of 833 lbs/yd³ (494 kg/m³) Type IP blended cement in the mix.

Limit the water-cementitious material ratio to a maximum of 0.45. Do not air-entrain Drilled Pier Concrete.

Produce a workable mix so that vibrating or prodding is not required to consolidate the concrete. When placing the concrete, make certain the slump is between 5 and 7 inches (125 and 175 mm) for dry placement of concrete or 7 and 9 inches (175 and 225 mm) for wet placement of concrete.

Use Type I or Type II cement or Type IP blended cement and either No. 67 or No. 78M coarse aggregate in the mix. Use an approved water-reducer, water-reducing retarder, high-range water-reducer, or high-range water-reducing retarder to facilitate placement of the concrete if necessary. Do not use a stabilizing admixture as a retarder in Drilled Pier Concrete without approval of the Engineer. Use admixtures that satisfy AASHTO M194 and add them at the concrete plant when the mixing water is introduced into the concrete. Redosing of admixtures is not permitted.

Place the concrete within 2 hours after introducing the mixing water. Ensure that the concrete temperature at the time of placement is 90°F (32°C) or less.

1. Slump Loss Test

If any drilled pier concrete pour is greater than 40 yd³ (31 m³) per pier, provide a slump loss test before beginning the drilled pier operation. The slump loss test verifies that the drilled pier concrete maintains a slump of at least 4 inches (100 mm) a minimum of 4 hours after batching. Perform the test with a Division of Highways representative present. Have the concrete producer notify the Department at least 72 hours prior to the test.

Conduct the slump loss test as follows:

- a. Batch the actual mix design at 9 inches (225 mm) initial slump and at the highest concrete temperature expected on the job, but no less than 60°F (15.5°C).
- b. Batch at least 4 yd³ (3 m³) in a mixer truck. Begin timing the test when the mixing water is introduced into the mix.
- c. After initial mixing, measure and record the slump, ambient temperature, concrete temperature and percent air. Ensure all concrete properties are within specifications.
- d. Mix the concrete intermittently at agitation speed for 30 seconds every 15 minutes.

- e. Measure and record the slump, ambient and concrete temperatures, and percent air after every second 15 minute interval until the slump is 3½ inches (90 mm).

Make certain the concrete maintains a minimum slump of 4 inches (100 mm) 4 hours after batching.

Once a mix design is accepted and the slump loss test is on file with the Materials and Tests Unit, resubmit the design for subsequent projects without the slump loss test.

B. Concrete Placement

Place concrete such that the drilled pier is a monolithic structure. Vibration is only permitted, if needed, in the top 10 feet (3 m) of the drilled pier or as directed by the Engineer. Remove any contaminated concrete from the top of the drilled pier and the wasted concrete from the area surrounding the drilled pier. Contain all concrete that spills over the permanent casing of the drilled pier.

Do not remove temporary casing until the level of concrete within the casing is in excess of 10 feet (3 m) above the bottom of the casing being removed. Maintain the concrete level at least 10 feet (3 m) above the bottom of innermost casing throughout the entire casing extraction operation, except when concrete is at or above the top of drilled pier elevation. Sustain a sufficient head of concrete above the bottom of casing to overcome outside soil and water pressure. As the casing is withdrawn, exercise care in maintaining an adequate level of concrete within the casing so that fluid trapped behind the casing is displaced upward and discharged at the ground surface without contaminating or displacing the drilled pier concrete. Exerting downward pressure, hammering and/or vibrating the temporary casing is permitted to facilitate extraction.

After all the pumps have been removed from the excavation, the water inflow rate determines the concrete placement procedure. If the inflow rate is less than 6 inches (150 mm) per half hour, the concrete placement is considered dry. If the water inflow rate is greater than 6 inches (150 mm) per half hour, the concrete placement is considered wet.

Keep a record of the volume of concrete placed in each drilled pier excavation and make it available to the Engineer. For drilled piers constructed with slurry or as directed by the Engineer, record a graphical plot of the depth versus theoretical concrete volume and actual measured concrete volume for each drilled pier and provide it to the Engineer when finished placing concrete.

1. Dry Placement

Prior to placing concrete, make certain the drilled pier excavation is dry so the flow of concrete completely around the reinforcing steel can be certified by visual inspection. If the concrete free fall does not exceed 60 feet (18.3 m), placing the concrete by a central drop method where the concrete is chuted directly down the center of the excavation is permitted.

For drilled piers exceeding 60 feet (18.3 m) in length, use a tremie or a pump to place concrete as described in Section 6.0, Item B, Number 3. Support the tremie or pump so that the concrete free fall is less than 60 feet (18.3 m) at all times.

2. Wet Placement

Maintain a static water or slurry level in the excavation prior to placing concrete underwater. When temporary casing is used as the method to stabilize the excavation, place concrete only with a pump (no tremie).

Once the concrete in the excavation reaches the same elevation as the static water level, placing concrete with the dry method is permitted. Before changing to the dry method of concrete placement, remove the water above the concrete and clean the concrete surface of all scum and sediment to expose clean, uncontaminated concrete.

3. Tremie and Pump

Place concrete with a tremie or a pump in accordance with the applicable parts of Sections 420-6 and 420-8 of the Standard Specifications that concern tremie and/or concrete pumping operations. Use a tremie consisting of a sectional tube a minimum of 10 inches (254 mm) in diameter unless otherwise approved or directed by the Engineer. Use a tremie tube or pump pipe made of steel with watertight joints. Passing concrete through a hopper at the tube end or through side openings as the tremie is retrieved during concrete placement is permitted. Use a discharge control to prevent concrete contamination when the tremie tube or pump pipe is initially placed in the excavation. Extend the tremie tube or pump pipe into the concrete a minimum of 5 feet (1.5 m) at all times except when the concrete is initially introduced into the pier excavation. If the tremie tube or pump pipe pulls out of the concrete for any reason after the initial concrete is placed, restart concrete placement with a steel capped tremie tube or pump pipe.

4. Placement Time

Place concrete within the time frames specified in Table 1000-2 of the Standard Specifications for Class AA concrete and this special provision. Never place concrete so fast as to trap air, slurry, water, fluids, soil or any other deleterious materials in the vicinity of the reinforcing steel and the annular zone between the rebar cage and the excavation walls. Should a delay occur because of concrete delivery or other factors, reduce the placement rate to maintain some movement of the concrete. No more than 45 minutes is allowed between placements.

7.0 SCHEDULING AND RESTRICTIONS

After the first drilled pier is successfully completed, do not make any significant changes in construction methods, equipment or materials, unless approved by the Engineer.

If caving or sloughing occurs, compensation is not provided for additional concrete to fill the resulting voids.

Within the first 16 hours after a drilled pier has achieved its initial concrete set (as determined by the Engineer), do not drill adjacent piers, do not install adjacent piles, and do not allow any equipment wheel loads or "excessive" vibrations to occur at any point within a 20 foot (6 m) radius of the drilled pier.

In the event that the procedures described herein are performed unsatisfactorily, the Engineer reserves the right to shut down the construction operations and/or reject the drilled piers. If the integrity of a drilled pier is in question, use core drilling, sonic or other approved methods at no additional cost to the Department and under the direction of the Engineer. Dewater and backfill core drill holes with an approved high strength grout with a minimum compressive strength of 4500 psi (31.0 MPa) as directed by the Engineer. Remedial measures are directed by and require approval from the Engineer. No compensation will be paid for losses or damage due to remedial work or any investigation of drilled piers found defective or not in accordance with this special provision or the construction plans.

8.0 NON-DESTRUCTIVE TESTING (NDT)

The Engineer furnishes the non-destructive testing (NDT) equipment. NDT requires the attachment of an accelerometer to the top of the drilled pier. Measurements are made while tapping the top of the drilled pier with a hammer. The Engineer furnishes the materials, labor and equipment necessary for the installation of the accelerometer.

If the NDT instruments and supporting equipment are damaged due to the fault or negligence of the Contractor, replace the damaged equipment at no additional cost to the Department.

After installation, notify the Engineer that the drilled piers are ready to be tested. A drilled pier is tested only after the concrete has been in place for 5 days and the concrete has achieved a minimum compressive strength of 3000 psi (20.7 MPa). Grind four flat dry areas on top of the drilled pier down to exposed aggregate with a grinder or some other acceptable device. The Engineer selects the location of the four ground surfaces. Several velocity records as a function of time are averaged at each test location. The NDT field data is recorded with digital data acquisition equipment. Field testing is estimated to take 1 hour per drilled pier. Evaluation and interpretation of the field data requires 3 working days after testing. Further construction above the drilled piers that were tested is not allowed until the analysis of the NDT field data is complete.

The Engineer determines the number of drilled piers to be tested with NDT. It is anticipated that all drilled piers require testing. The cost of this work is included in the contract unit price bid for the drilled pier pay items. No separate payment will be made. Claims are not permitted for any delay incurred, including but not limited to the installation of the instrumentation or the collection and analysis of the NDT data.

9.0 COMPENSATION

A. Method of Measurement

1. Drilled Piers in Soil

The quantity of "Drilled Piers in Soil" to be paid for will be the linear feet (meters) of the drilled piers exclusive of the linear feet (meters) of "Drilled Piers Not in Soil" computed from elevations and dimensions as shown on the plans or from revised dimensions authorized by the Engineer. Drilled piers through air or water will be paid for as "Drilled Piers in Soil".

2. Drilled Piers Not in Soil

The quantity of "Drilled Piers Not in Soil" to be paid for will be the linear feet (meters) of drilled piers excavated in non-soil as determined by the Engineer. Non-soil is defined as material that can not be cut with a rock auger and requires excavation by coring, air tools, hand removal or other acceptable methods. Top of non-soil elevation is that elevation where the rock auger penetration rate is less than 2 inches (50 mm) per 5 minutes of drilling at full crowd force and coring, air tools, etc. are used to advance the excavation. For pay purposes, after non-soil is encountered, earth seams, rock fragments and voids in the excavation less than 3 feet (0.9 m) in total length will be considered "Drilled Piers Not in Soil". If the non-soil is discontinuous, payment will revert to "Drilled Piers in Soil" at the elevation where non-soil is no longer encountered.

3. Permanent Steel Casing

The quantity of "Permanent Steel Casing" to be paid for will be the linear feet (meters) of permanent steel casing as directed and authorized to be used. The length to be paid for will be measured along the permanent casing from the top of the casing elevation or top of the pier elevation, whichever is lower, to the casing tip elevation. Casing will be paid for only when permanent casing is authorized or when the Engineer directs the Contractor to leave a casing in place that then becomes a permanent part of the pier. No payment will be made for temporary steel casings that become bound or fouled during pier construction and cannot be practically removed.

4. Shaft Inspection Device (SID)

The quantity of "SID Inspection" to be paid for will be per drilled pier as noted on the plans and/or directed by the Engineer. SID inspections are performed until the

bottom cleanliness of the drilled pier excavation is acceptable by this special provision; however, payment will only be made for the initial SID inspection of each drilled pier excavation.

5. Standard Penetration Test (SPT)

The quantity of "SPT Testing" to be paid for will be the actual number of SPT tests performed as noted on the plans and/or directed by the Engineer.

B. Basis of Payment

1. Drilled Piers in Soil

Payment will be made at the contract unit price per linear foot (meter) for "____ Dia. Drilled Piers in Soil". Such payment will include, but is not limited to, furnishing all labor, tools, equipment, materials including concrete complete and in place and all incidentals necessary to excavate the drilled piers and complete the work as described in this special provision. No additional payment will be made for slurry use. No additional payment will be made for any miscellaneous grading or excavation to install the drilled pier. "Reinforcing Steel" and "Spiral Column Reinforcing Steel" will be paid for separately and will not be part of this pay item.

2. Drilled Piers Not in Soil

Payment will be made at the contract unit price per linear foot (meter) for "____ Dia. Drilled Piers Not in Soil". Such payment will include, but is not limited to, furnishing all labor, tools, equipment, materials including concrete complete and in place and all incidentals necessary to excavate the drilled piers and complete the work as described in this special provision. No additional payment will be made for slurry use. No additional payment will be made for any miscellaneous grading or excavation to install the drilled pier. "Reinforcing Steel" and "Spiral Column Reinforcing Steel" will be paid for separately and will not be part of this pay item.

3. Permanent Steel Casing

Payment will be made at the contract unit price per linear foot (meter) for "Permanent Steel Casing for ____ Dia. Drilled Pier". Such payment will include, but is not limited to, furnishing all material, labor, tools, equipment and all incidentals necessary to install the casing in the pier excavation.

4. Shaft Inspection Device (SID)

Payment for SID will be at the contract unit price per each for "SID Inspection". Such payment will include, but is not limited to, furnishing all materials, labor, tools, equipment and all incidentals necessary to complete the SID inspection as described in this special provision.

5. Standard Penetration Test (SPT)

Payment for SPT will be at the contract unit price per each for "SPT Testing". Such payment will include, but is not limited to, furnishing all materials, labor, tools, equipment and all incidentals necessary to complete the SPT at each test location.

CROSSHOLE SONIC LOGGING

(7-09-02)

1.0 GENERAL

Use the non-destructive testing method called Crosshole Sonic Logging (CSL) to verify the integrity of the drilled pier and the quality of the concrete. The Engineer will determine the number of CSL tests and which drilled piers will be CSL tested on this project. Drilled piers are referred to as piers in this special provision.

The CSL test measures the time for an ultrasonic pulse to travel from a signal source in one access tube to a receiver in another access tube. In uniform, good quality concrete, the travel time between equidistant tubes should yield relatively consistent arrival times and corresponds to a reasonable pulse velocity, signal amplitude and energy from the bottom to the top of the pier. Longer travel times, decrease in pulse velocity, and lower amplitude/energy signals indicate the presence of irregularities such as poor quality concrete, voids, honeycombing, cracking and soil intrusions. The signal may be completely lost by the receiver and CSL recording system for severe defects such as voids and soil intrusions.

The CSL Consultant must have a minimum 3 years experience of CSL testing and have a Registered North Carolina Professional Engineer supervising the testing and interpretation of results. **Submit** the proposed CSL Consultant to the Engineer for approval 30 days before beginning drilled pier construction. The following evidence of qualification needs to be included, unless previously approved by the Department and no changes have occurred since previous submittal:

- Written evidence of successful completion of CSL tests, brief descriptions and reference's phone numbers for three recent CSL projects.
- Personnel qualifications
- Equipment description
- Example report

Make all necessary arrangements with the CSL Consultant to have the CSL tests satisfactorily performed on the selected drilled piers and in accordance with this special provision. The CSL Consultant must supply to the Contractor technical instruction and guidance in preconstruction activities, and on-site technical assistance and guidance during set up and performance of the CSL tests. Provide suitable access to the site and to the top

of piers to be tested. Follow instructions from the CSL Consultant unless the Engineer directs otherwise.

Place CSL tubes in all drilled piers. Perform CSL testing only on drilled piers selected by the Engineer a minimum 7 days after concrete placement and after concrete achieves a minimum compressive strength of 3000 psi (20.7 MPa), but within 30 days after concrete placement. After CSL test results have been reviewed and the Engineer has accepted the drilled pier or approves grouting of the tubes, dewater the tubes and core holes, if any, and backfill with the approved grout. When the Engineer elects not to CSL test a pier, dewater the tubes and backfill them with an approved 4500 psi (31.0 MPa) compressive strength grout.

2.0 PREPARATION FOR CSL

Install four tubes in each drilled pier with a diameter of 5 feet (1524 mm) or less, and install six tubes in each pier with a diameter of greater than 5 feet (1524 mm). Provide 2 inch (50 mm) inside diameter Schedule 40 steel pipe conforming to ASTM A53, Grade A or B, Type E, F, or S. The tubes must have a round, regular internal diameter free of defects or obstructions, including any at tube joints, in order to permit the free, unobstructed passage of source and receiver probes. The tubes must provide a good bond with the concrete, and be watertight.

Fit the tubes with a watertight threaded cap on the bottom and a removable threaded cap on the top. Securely attach the tubes to the interior of the reinforcement cage. Install the tubes in each drilled pier in a regular, symmetric pattern such that each tube is equally spaced from the others around the perimeter of the cage. Tube placement must be such that large vertical reinforcing bars do not block the direct line between adjacent tubes. The tubes are typically wire-tied to the reinforcing cage every 3 feet (1 m) or otherwise secured such that the tubes remain in position during placement of the rebar cage and the concrete. The tubes must be as near to vertical and as parallel as possible, **as non-vertical tubes can adversely affect data analysis**. Extend the tubes from 6 inches (150 mm) above the pier tip to at least 3 feet (1 m) above the top of the pier. If the pier top elevation is below ground elevation, extend tubes at least 2 feet (610 mm) above ground surface. If the drilled pier tip elevation is excavated more than 1 foot (305 mm) below the tip elevation in the original plans, extend the tubes using proper threaded mechanical couplings to within 6 inches (150 mm) of the revised pier tip elevation.

Before placement of the reinforcement cage into the drilled pier, record the tube lengths and tube positions along the length of the cage. After placement of concrete, measure the stickup of the tubes above the top of the drilled piers and verify tube spacing.

Verify that unobstructed passage of the probes is achievable before the CSL Consultant arrives on site. If testing equipment will not pass through the entire length of the CSL tube, core a 2 inch (50 mm) diameter hole through the concrete the full length of the drilled pier at no cost to the Department. Locate the core hole approximately 9 inches (230 mm) inside the pier reinforcement from obstructed tube or as determined by the Engineer. Fill core hole with clean, potable water and cover to keep out debris.

Immediately after placement of the reinforcement cage and within 2 hours after concrete placement, fill the CSL tubes with clean, potable water, and cap them to keep out debris. The Engineer will reject CSL tubes that are not filled with water or capped. When removing the caps, exercise care not to apply excess torque, force or stress, which could break the bond between the tubes and the concrete.

Submit to the Engineer the CSL tube size, the manufacturer's certificate of compliance, cap details, couplings, any joints details, and the proposed method of attaching the tubes, 30 days before beginning drilled pier construction.

3.0 CSL EQUIPMENT

The minimum requirements of the CSL equipment are as follows:

- A microprocessor based CSL system for display of individual CSL records, analog-digital conversion and recording of CSL data, analysis of receiver responses and printing of report quality CSL logs
- Ultrasonic source and receiver probes which can travel through 2 inch (50 mm) I.D. steel pipe
- An ultrasonic voltage pulser to excite the source with a synchronized triggering system to start the recording system
- A depth measurement device to electronically measure and record the source and receiver depths associated with each CSL signal
- Appropriate filter/amplification and cable systems for CSL testing
- An acquisition system that stores each log in digital format, with drilled pier identification, date, time and test details, including the source and receiver gain. Arrival time data must be displayed graphically during data acquisition.
- 3D tomographic imaging software, or source for completing the work

4.0 CSL TEST PROCEDURE

Provide the Engineer and CSL Consultant with the following:

- Tube lengths and positions
- Record of the drilled pier construction information including the pier bottom and top elevations
- Construction dates before CSL testing

Conduct CSL tests between each perimeter pair and major principal diameter and log, unless otherwise directed by the Engineer.

Perform the CSL testing with the source and receiver probes in the same horizontal plane unless test results indicate defects or poor concrete zones, in which case the defect zones must be further evaluated with angle tests (source and receiver vertically offset at greater than 1.5 feet (460 mm) in the tubes). Report any defects indicated by decreased signal velocity and lower amplitude/energy signals to the Engineer at the time of testing, and conduct angle tests in the zones of the defects as defined by the Concrete Condition Rating Criteria (CCRC) in Section 5.0 of this special provision. Make CSL measurements at depth intervals of 2 ½ inches (65 mm) or less from the bottom of the tubes to the top of each pier. Pull the probes simultaneously, starting from the bottom of the tubes, using a depth-measuring device to electronically measure and record the depths associated with each CSL signal. Remove any slack from the cables before pulling to provide for accurate depth measurements of the CSL records. In the event defects are detected, conduct additional logs, as needed, at no additional cost to the Department. The Department will not accept any claims for either lost time or the actual expense of further investigation of defects.

If steel tube debonding occurs, then core drill a 2 inch (50 mm) diameter hole to the depth of debonding for each debonded tube in order to perform the CSL logs at no additional cost to the Department.

5.0 CSL RESULTS AND REPORTING

Submit the test results in the form of a report including four original copies of CSL results to the Engineer within 5 working days of completion of CSL testing. The CSL report should include but not limited to the following:

- Project identification
- Dates of testing
- Table and a plan view of each pier tested with accurate identification of tube coordinates and tubes referenced to the site
- Tube collar elevation
- Names of personnel that performed the tests/interpretation and their affiliation
- Equipment used
- Interpretation, analysis, and results.

Include CSL logs for each tube pair tested with analysis of the initial pulse arrival time, velocity, relative pulse energy/amplitude, and stacked waveform plotted versus depth. List all zones defined by the Concrete Condition Rating Criteria (CCRC) in a tabular format including the percent velocity reduction and the velocity values used from the nearby zone of good quality concrete. Discuss each zone defined by the CCRC in the CSL report as appropriate. Base the results on the percent reduction in velocity value from a nearby zone of good quality concrete with good signal amplitude and energy as correlated to the following:

Concrete Condition Rating Criteria (CCRC)			
CCRC	Rating Symbol	Velocity Reduction	Indicative Results
Good	G	≤ 10 %	Good quality concrete
Questionable Defect	Q	>10 % & < 20 %	Minor concrete contamination or intrusion. Questionable quality concrete.
Poor	P/D	≥ 20 %	Defects exist, possible water/slurry contamination, soil intrusion, and/or poor quality concrete.
No Signal	NS	No Signal received	Soil intrusion or other severe defect absorbed the signal (assumes good bond of the tube-concrete interface).
Water	W	V = 4750 fps (1450 mps) to 5000 fps (1525 mps)	Water intrusion, or water filled gravel intrusion with few or no fines present.

The following are a few examples of types and causes of defects:

- Necking or arching of the concrete on withdrawal of the temporary casing.
- Necking or contamination of the concrete due to collapse of the side walls.
- Soft toe due to incomplete cleaning or collapse of the side walls.
- Horizontal lenses of silt\mud\bentonite due to the tremie pipe rising above the concrete
- Voids due to the use of low-slump concrete.
- Honeycombing due to washout of fines.
- Trapping of contaminants due to pumping concrete too fast.

Provide the original pulse signal data files and ASCII format of the picks with a header (identifying the pier tested, tube coordinates and each data column) in an electronic file to the Engineer. The Engineer will require 7 working days to evaluate the CSL test results and determine whether or not the drilled pier is acceptable. Evaluation of CSL test results, with ratings other than good (G) per the Concrete Condition Rating Criteria (CCRC) may require further investigation and additional time for review and analysis of the data. Do not grout the CSL tubes or perform any further work on the CSL tested drilled pier until the Engineer determines whether the drilled pier is acceptable. Perform tomography in order to further investigate and delineate the boundaries of any defective/unconsolidated zones with 20% or more reduction in velocity value as correlated to the CCRC. Process CSL data to construct easy to understand 2D/3D (2D cross-sections between tubes and 3D volumetric images for the entire pier) *color-coded* tomographic images indicating velocity variations along the pier. Location and geometry of defective/unconsolidated zones must be identified in 3D color images with detailed discussion in the CSL report. Any further tests deemed necessary by the Engineer in order to determine the acceptability of the drilled pier will be determined after reviewing the CSL report. Additional test or analysis options include 3D tomographic imaging, single-hole sonic testing, gamma-gamma nuclear density logging, sonic echo or impact response tests, and concrete coring, in addition to load testing of the piers.

The Engineer will determine the depth, location, and the number of core holes when concrete coring is required. Drill a minimum of two PQ size core holes to intercept the suspected defect zones. Use a coring method that provides maximum core recovery and minimizes abrasion and erosion. Provide concrete cores properly marked in a wooden crate and labeling the drilled pier depth at each interval of core recovery to the NCDOT Materials and Test Unit for evaluation and testing. Submit to the Engineer a drilling report that includes the NCDOT project number, name of the Drilling Contractor, date drilled, percent core recovery and signed by the Contractor. Allow 7 working days after submitting the core records for the Department's review.

6.0 CORRECTION OF UNACCEPTABLE DRILLED PIER

When the Engineer determines a drilled pier is unacceptable, the Engineer will direct the Contractor to submit remedial measures to the Department for approval. No compensation will be made for remedial work or losses or damage due to remedial work of drilled piers found defective or not in accordance with the drilled pier special provision or the construction plans. Modifications to the drilled pier design or any load transfer mechanisms required by the remedial action must be designed and calculations sealed by a Registered North Carolina Professional Engineer. Include drawings sealed by a Registered North Carolina Professional Engineer for all foundation elements affected. Do not begin remedial action work until the Department has reviewed and accepted the remedial action plan. Allow 10 working days after submitting the remedial work plan for the Department's review and acceptance. Furnish all materials and work necessary to correct defective drilled piers.

7.0 MEASUREMENT AND BASIS OF PAYMENT

The complete and accepted CSL testing will be paid for at the unit bid price for “Crosshole Sonic Logging” per each, which will constitute full compensation for all costs incurred for procurements, conducting the CSL testing, including any other test required to determine acceptability, reporting of results and incidentals necessary to complete the work.

The complete and accepted crosshole sonic logging tubes will be paid for at the unit bid price for “CSL Tubes” per foot (meter) of tube. The unit bid price will constitute full compensation for furnishing, installing, extending tubes, dewatering and grouting of all CSL tubes and 2 inch (50 mm) diameter core holes, if applicable, and for all materials, labor, tools, equipment and incidentals necessary to complete the work.

STEEL PILE POINTS

(10-12-01)

Provide steel pile points in accordance with the plans, applicable parts of the Standard Specifications, and this provision.

The following is a list of approved pile points:

Brand Name	Manufacturer	Pile Size
PAR 12T Super-Bite Point	Piling Accessories, Inc.	HP 12x53 (HP 310x79)
HPH-12-RB-1	International Construction Equipment, Inc.	HP 12x53 (HP 310x79)
PAR 14T Super-Bite Point	Piling Accessories, Inc.	HP 14x73 (HP 360x108)

For pile points not on the approved list, as a condition of approval, submit seven copies of the proposed pile point and attachment details for acceptance prior to use as stated in Subarticle 450-8(D) of the Standard Specifications.

When approved pile points are used, the submission procedure as stated in Subarticle 450-8(D) of the Standard Specifications is waived.

Provide the Engineer with the manufacturer’s welding and attachment details. Weld pile points to the pile in accordance with the manufacturer’s details as approved. The minimum weld length is twice the width of the flange.

MECHANICAL BUTT SPLICING FOR REINFORCING STEEL

(10-12-01)

1.0 GENERAL

When mechanically butt splicing reinforcing steel, use a standard metal filled sleeve, cement mortar filled sleeve, threaded steel couplings, forged steel sleeve, cold-forged sleeve or an exothermic process whereby molten filler metal, contained by a high strength steel sleeve of larger inside diameter than the bars, is introduced into the annular space between the bars and the sleeve and also between the ends of the bars. Provide a splice that is capable of transferring at least 125% of the yield strength of the bars from one bar to the other by the mechanical strengths of the splice components.

The following is a list of approved connectors:

Brand Name	Approved Size
Bar-Lock Couplers	#4 - #11 (#13 - #36)
Barsplice Products	
Bar-Grip System	#4 - #18 (#13 - #57)
Grip-Twist System	#4 - #18 (#13 - #57)
Threaded Dowel Bar Coupler	#4 - #8 (#13 - #25)
Erico	
Lenton Interlok Grout-Filled Coupler	#6 - #11 (#19 - #36)
Lenton Position Coupler	#4 - #18 (#13 - #57)
Lenton Standard Coupler	#4 - #18 (#13 - #57)
Quick-Wedge Coupler	#4 - #6 (#13 - #19)
Richmond DB-SAE Dowel Bar Splicer	#4 - #11 (#13 - #36)
Williams Form Engineering Flange Coupler	#4 - #14 (#13 - #43)
Zap Screwlok	#4 - #11 (#13 - #36)

For splices not on the approved list, as a condition of approval, assemble three test splices in the presence of the Engineer for each of the bar materials identical to that which is proposed for use in the structure and forward the test splices to N. C. Department of Transportation Materials and Tests Unit in Raleigh, N.C.

When an exothermic connector is used, do not let the splice depend upon fusion of the filler metal with the bars. Select a temperature for heating the bars that is below the melting point of the bars and is sufficiently low so as not to significantly affect the original hardness nor decrease the structural properties of the bars. Visual inspection of the finished splices is sufficient; the splice is acceptable if sound filler metal is present at both ends of the splice sleeve and at the sleeve entry port.

Splice the bars in accordance with the manufacturer's recommendations using the manufacturer's required accessories as approved by the Engineer. Use mechanical butt splices only where specified on the plans. Any additional splices require approval.

If bars are epoxy coated, strip the epoxy coating within the limits of the sleeve prior to splicing. After making the splice, paint any unprotected areas of the reinforcing bar and the coupling sleeve with epoxy paint as described in the Standard Specifications.

2.0 BASIS OF PAYMENT

No separate measurement or payment will be made for this work. The following pay items will be full compensation for the above work as follows:

- The unit contract price bid for "Reinforced Concrete Deck Slab" will be full compensation for mechanical butt splices in concrete decks.
- The unit contract price bid for "Reinforcing Steel" or "Epoxy Coated Reinforcing Steel" will be full compensation for mechanical butt splices in bridge substructures and cast-in-place culverts.

MINIMIZING RAILROAD FLAGGING SERVICE

(10-12-01)

Notify the Engineer whenever construction activity on, or immediately adjacent to, the railroad right-of-way is expected to be delayed for more than 2 weeks due to:

- Construction activity being confined to an area where the activity, including the possible falling or overturning of proposed construction equipment and/or material, is not reasonably expected to interfere with Railroad operations or cause damage to facilities of the Railroad or its tenants, and where Railroad operations would not affect personnel and/or equipment.
- The Contractor removing his work force from the site to pursue his work at other locations.
- Scheduling of needed construction equipment and/or material
- Coordination with other required construction activity
- Seasonal considerations

In the notification, describe the reason for the delay and provide a schedule of when the delay in the area is expected to begin and when work in the area is expected to resume.

Contact the Railroad's authorized representative to determine if the flagman can be released and reassigned to accommodate the proposed work delay schedule. If the Railroad agrees, the Engineer follows the advance notification procedures for releasing and rescheduling a flagman as stated elsewhere in this Special Provision or as provided by the Railroad.

Prior to the release of the flagman, ensure that drainage facilities and erosion control measures adjacent to the tracks are properly maintained and that the site is left in a condition satisfactory to the Railroad. In addition, remove any material or equipment stored on the Railway right of way that is needed during the absence of the flagman.

If failing to notify the Engineer of a construction activity delay as stated above and a flagman remains assigned to the site for more than 2 weeks after the delay begins, the flagman time exceeding the 2 weeks, until work resumes on a routine schedule, is considered the Contractor's responsibility.

For that portion of the flagman time considered as the Contractor's responsibility, the Department will continue to pay the flagging charges but an amount of \$250 per day will be withheld from partial or final payment due the Contractor.

ADHESIVELY ANCHORED ANCHOR BOLTS OR DOWELS

(10-12-01)

1.0 DESCRIPTION

The work covered by this Special Provision consists of furnishing all necessary labor, equipment, and materials and performing all operations necessary for installing anchor bolts/dowels in concrete using an adhesive bonding system in accordance with the details shown on the plans and with the requirements of this specification unless otherwise directed.

Submit a description of the proposed adhesive bonding system to the Engineer for review, comments and acceptance. Include in the description the bolt type and its deformations, equipment, manufacturer's recommended hole diameter, embedment depth, material specifications, and any other material, equipment or procedure not covered by the plans or these specifications. List the properties of the adhesive, including density, minimum and maximum temperature application, setting time, shelf life, pot life, shear strength and compressive strength. If bars/dowels containing a corrosion protective coating are required, provide an adhesive that does not contain any chemical elements that are detrimental to the coating and include a statement to this effect in the submittal.

2.0 MATERIALS

Use an adhesive bonding system that has been tested for a tensile strength of 125% of the specified anchor bolt/dowel yield load. Provide certification that, for the particular bolt grade, diameter and embedment depth required, the anchor system will not fail by adhesive failure and that the anchor bolt/dowel will not move. The minimum concrete compressive strength is 3000 psi (20.7 MPa) for certification and anchorage selection.

Package components of the adhesive so that one whole container of each component mixes to form one batch of adhesive. Use containers designed so that all of the contents may be removed easily and sealed tightly to prevent leakage. Furnish adhesive material requiring hand mixing in two separate containers designated as Component A and Component B. Provide a self contained cartridge or capsule consisting of two components which are automatically mixed as they are dispensed, as in the case of a cartridge, or drilled into, as in the case of a capsule.

Clearly label each container with the manufacturer's name, date of manufacture, batch number, batch expiration date, direction for use, and warnings and precautions concerning the contents as required by State or Federal Laws and Regulations.

3.0 PROCEDURE

C. Drilling of Holes into Concrete

When directed, use a jig or fixture to ensure the holes are positioned and aligned correctly during the drilling process. Upon approval, adjusting hole locations to avoid reinforcing steel is permitted.

Drill the holes with a pneumatic drill unless another drilling method is approved. Follow the manufacturer's recommendations regarding the diameter of the drilled hole.

Immediately after completion of drilling, blow all dust and debris out of the holes with oil-free compressed air using a wand extending to the bottom of the hole. Remove all dust from the sides of the holes by brushing the holes with a stiff-bristled brush of a sufficient size and then blow the hole free of dust. Repeat this procedure until the hole is completely clean. Check each hole with a depth gauge to ensure proper embedment depth.

Repair spalled or otherwise damaged concrete using approved methods.

D. Inspection of Holes

Inspect each hole immediately prior to placing the adhesive and the anchor bolts/dowels. Ensure all holes are dry and free of dust, dirt, oil, and grease. Rework any hole that does not meet the requirements of this Special Provision.

E. Mixing of Adhesive

Mix the adhesive in strict conformance with the manufacturer's instructions.

F. Embedment of Anchor Bolt/Dowel

Clean each anchor bolt/dowel so that it is free of all rust, grease, oil, and other contaminants.

Unless otherwise shown on the plans, the minimum anchor bolt/dowel embedment depth is such that the adhesive develops at least 125% of the anchor bolt/dowel yield load as determined by the manufacturer.

Insert the anchor bolt/dowel the specified depth into the hole and slightly agitate it to ensure wetting and complete encapsulation. After insertion of the anchor bolt/dowel, strike off any excessive adhesive flush with the concrete face. Should the adhesive fail to fill the hole, add additional adhesive to the hole to allow a flush strike-off.

Do not disturb the anchor bolts/dowels while adhesive is hardening.

4.0 FIELD TESTING

When specified on the plans, test the installed anchor bolts/dowels for adequate adhesive as specified below. Inform the Engineer when the tests will be performed at least 2 days prior to testing. Conduct the tests in the presence of the Engineer.

Use a calibrated hydraulic centerhole jack system for testing. Place the jack on a plate washer that has a hole at least 1/8 inch (3 mm) larger than the hole drilled into the concrete. Position the plate washer on center to allow an unobstructed pull. Position the anchor bolts/dowels and the jack on the same axis. Have an approved testing agency calibrate the jack within 6 months prior to testing. Supply the Engineer with a certificate of calibration.

In the presence of the Engineer, field test 10% of the first 50 anchor bolts/dowels prior to installing any additional anchors. For testing, apply and hold briefly 90% of the anchor bolt/dowel yield load shown on the plans. No visible signs of movement of the anchor bolts/dowels is permitted under this load. Upon receiving satisfactory results from these tests, install the remaining anchors. Test a minimum of 2% of the remaining anchors as previously described.

Record data for each anchor bolt/dowel tested on the report form entitled "Installation Test Report of Adhesively Anchored Anchor Bolts or Dowels". Obtain this form from the North Carolina Department of Transportation Materials and Tests Engineer. Submit a copy of the completed report forms to the Engineer.

Final acceptance of the adhesively anchored system is based on the conformance of the pull test to the requirements of this specification. Failure to meet the criteria of this specification is grounds for rejection.

5.0 BASIS OF PAYMENT

No separate measurement or payment will be made for furnishing, installing, and testing anchor bolts/dowels.

Payment at the contract unit prices for the various pay items will be full compensation for all materials, equipment, tools, labor, and incidentals necessary to complete the above work.

EVAZOTE JOINT SEALS**(8-13-04)****1.0 SEALS**

Use preformed seals compatible with concrete and resistant to abrasion, oxidation, oils, gasoline, salt and other materials that are spilled on or applied to the surface. Use a low-density closed cell, cross-linked ethylene vinyl acetate polyethylene copolymer nitrogen blown material for the seal.

Use seals manufactured with grooves 1/8" (3 mm) ± wide by 1/8" (3 mm) ± deep and spaced between 1/4 (6 mm) and 1/2 inch (13 mm) apart along the bond surface running the length of the joint. Use seals sized so that the depth of the seal meets the manufacturer's recommendation, but is not less than 70% of the uncompressed width. Provide a seal designed so that, when compressed, the center portion of the top does not extend upward above the original height of the seal by more than 1/4 inch (6 mm). Splice the seal using the heat welding method by placing the joint material ends against a teflon heating iron of 350°F (177°C) for 7 - 10 seconds, then pressing the ends together tightly. Do not test the welding until the material has completely cooled. Use material that resists weathering and ultraviolet rays. Provide a seal that has a working range of 30% tension and 60% compression and is watertight along its entire length including the ends.

Provide seals that meet the requirements given below.

TEST	TEST METHOD	REQUIREMENT
Elongation at break	ASTM D3575	210 ± 15%
Tensile strength, psi (kPa)	ASTM D3575	110 ± 15 (755 ± 100)
Compression Recovery (% of original width)	AASHTO T42 50% compr. for 22 hr. @ 73°F (23°C) 1/2 hr. recovery	87 ± 3
Weather/Deterioration	AASHTO T42 Accelerated Weathering	No deterioration for 10 years min.
Compression/Deflection	@ 50% deflection of original width @ 50% deflection of original width	10 psi (69 kPa) min. 60 psi (414 kPa) max.
Tear Strength, psi (kPa)	ASTM D624	16 ± 3 (110 ± 20)
Density	ASTM D545	2.8 to 3.4
Water Absorption (% vol/vol)	ASTM D3575 Total immersion for 3 months	3

Have the top of the evazote seal clearly shop marked. Inspect the evazote seals upon receipt to ensure that the marks are clearly visible upon installation.

2.0 ADHESIVES

Use a two component, 100% solid, modified epoxy adhesive with the seal that meets the requirements of ASTM C881, Type 1, Grade 3, Class B & C and has the following physical properties:

Tensile strength.....	3500 psi (24.1 MPa) min.
Compressive strength.....	7000 psi (48.3 MPa) min.
Shore D Hardness	75 psi (0.5 MPa) min.
Water Absorption.....	0.25% by weight

Use an adhesive that is workable to 40°F (4°C). When installing in temperatures below 40°F (4°C) or for application on moist, difficult to dry concrete surfaces, use an adhesive specified by the manufacturer of the joint material.

3.0 SAWING THE JOINTS

When the plans call for sawing the joints, the joints shall be initially formed to a width as shown on the plans including the blockout for the elastomeric concrete. Complete placement of the elastomeric concrete after the reinforced concrete deck slab has cured for seven full days and reached a minimum strength of 3000 psi (20.7 Mpa).

Cure the elastomeric concrete for a minimum of 2 days prior to sawing the elastomeric concrete to the final width and depth as specified in the plans.

When sawing the joint to receive the evazote seal, always use a rigid guide to control the saw in the desired direction. To control the saw and to produce a straight line as indicated on the plans, anchor and positively connect a template or a track to the bridge deck. Do not saw the joint by visual means such as a chalk line. Fill the holes used for holding the template or track to the deck with an approved, flowable non-shrink, non-metallic grout.

Saw cut to the desired width and depth in one or two passes of the saw by placing and spacing two metal blades on the saw shaft to the desired width for compression seals.

The desired depth is the depth of the seal plus 1/4 inch (6 mm) above the top of the seal plus approximately 1 inch (25 mm) below the bottom of the seal. An irregular bottom of sawed joint is permitted as indicated on the plans. Grind exposed corners on saw cut edges to a 1/4" (6 mm) chamfer.

Remove any staining or deposited material resulting from sawing with a wet blade to the satisfaction of the Engineer.

Use extreme care to saw the joint straight to the desired width and to prevent any chipping or damage to sawed edges of the joint.

4.0 PREPARATIONS FOR SAWED JOINTS

When the plans call for sawing the joint, the Engineer thoroughly inspects the sawed joint opening for spalls, popouts, cracks, etc. Make all necessary repairs prior to blast cleaning and installing the seal.

Immediately before sealing, clean the joints by sandblasting with clean dry sand. Sandblast to provide a firm, clean joint surface free of curing compound, loose material and any foreign matter. Sandblast without causing pitting or uneven surfaces. The aggregate in the elastomeric concrete may be exposed after sandblasting.

After blasting, either brush the surface with clean brushes made of hair, bristle or fiber, blow the surface with compressed air, or vacuum the surface until all traces of blast products and abrasives are removed from the surface, pockets, and corners.

If nozzle blasting, use compressed air that does not contain detrimental amounts of water or oil.

Examine the blast cleaned surface and remove any traces of oil, grease or smudge deposited in the cleaning operations.

Bond the seal to the blast cleaned surface on the same day the surface is blast cleaned.

5.0 PREPARATIONS FOR ARMORED JOINTS

When the plans call for armored joints, form the joint and blockout openings in accordance with the plans. If preferred, wrap the temporary form with polyethylene sheets to allow for easier removal. Do not use form release agents.

A. Submittals

Submitting detailed working drawings is not required; however, submitting catalog cuts of the proposed material is required. In addition, direct the joint supplier to provide an angle segment placing plan.

B. Surface Preparation

Prepare the surface within the 48 hours prior to placing the elastomeric concrete. Do not place the elastomeric concrete until the surface preparation is completed and approved.

1. Angle Assembly

Clean and free metallized steel of all foreign contaminants and blast the non-metallized steel surfaces to SSPC SP-10. Blast-cleaning anchor studs is not required.

2. Concrete

Prior to placing the elastomeric concrete, thoroughly clean and dry all concrete surfaces. Sandblast the concrete surface in the blockout and clear the surface of all loose debris.

C. Elastomeric Concrete Placement

Make sure that a manufacturer's representative is present when placing elastomeric concrete. Do not place elastomeric concrete if the ambient air temperature is below 45°F (7°C).

Prepare and apply a primer, as per manufacturer's recommendations, to all vertical concrete faces, all steel components to be in contact with elastomeric concrete, and to areas specified by the manufacturer. Align the angles with the joint opening.

Prepare, batch, and place the elastomeric concrete in accordance with the manufacturer's instructions. Place the elastomeric concrete in the areas specified on the plans while the primer is still tacky and within 2 hours after applying the primer. Pay careful attention to properly consolidate the concrete around the steel and anchors. Trowel the elastomeric concrete to a smooth finish.

D. Joint Preparation

Prior to installing the seal, the Engineer thoroughly inspects the armored joint opening for proper alignment and full consolidation of elastomeric concrete under the angle assemblies. Make all necessary repairs prior to cleaning the joint opening and installing the seal.

Clean the armored joint opening with a pressure washer rated at 3000 psi (20.7 MPa) minimum at least 24 hours after placing the elastomeric concrete. Dry the cleaned surface prior to installing the seal.

Examine the cleaned surface and remove traces of oil, grease or smudge deposited during the cleaning operations.

Bond the seal to the cleaned surface on the same day the surface is cleaned.

6.0 SEAL INSTALLATION

Install the joint seal according to the manufacturer's procedures and recommendations and as recommended below. Do not install the joint seal if the ambient air temperature is below 45°F (7°C). Have a manufacturer's representative present during the installation of the first seal of the project.

Begin installation at the low end of the joint after applying the mixed epoxy to the sides of both the joint material and both sides of the joint, making certain to completely fill the grooves with epoxy. With gloved hands, compress the material and with the help of a blunt probe, push it down into the joint until it is recessed approximately 1/4 inch (6 mm) below the surface. Do not push the seal at an angle that would stretch the material. Once work on a joint begins, do not stop until it is completed. Clean the excess epoxy off the surface of the joint material *quickly* and *thoroughly*. Do not use solvents to remove excess epoxy. Remove excess epoxy in accordance with the joint manufacturer's recommendations.

Install the seal so that it is watertight. Testing of the joint seal is not required, but it is observed until final inspection.

7.0 BASIS OF PAYMENT

Payment for all evazote joint seals will be at the lump sum contract price bid for "Evazote Joint Seals" which prices and payment will be full compensation for furnishing all material, including elastomeric concrete when required, labor, tools and equipment necessary for installing these units in place and accepted.

EPOXY PROTECTIVE COATING

(10-12-01)

1.0 DESCRIPTION

This work consists of preparing the concrete surface and furnishing and applying an epoxy protective coating to the surfaces described in this Special Provision. When epoxy protective coating is required, cure the top surfaces of the bent or end bent caps in accordance with the Standard Specifications, but do not use the Membrane Curing Compound method.

2.0 MATERIALS

Use an epoxy coating that meets the most recently published NCDOT Specification on the date of advertisement. Use the epoxy coating that meets NCDOT-Type 4A Flexible, epoxy coating, moisture insensitive.

Provide a certification for the proposed epoxy showing that it meets NCDOT-Type 4A.

The following companies have epoxies that meet Type 4A Specifications:

- E-Bond Epoxy, Inc.
Fort Lauderdale, Florida 33307
- Permagile Industries
Plainview, NY 11803
- Poly-Carb
Cleveland, OH 44139

- Tamms, Inc.
Mentor, OH 44060
- Adhesive Engineering
Cleveland, OH 44122-5554
- Kaufman Products
Baltimore, MD 21226-1131
- Prime Resins
Lithonia, GA 30058
- Sika Corporation
Lyndhurst, N. J. 07071

A copy of the specifications for Epoxy Resin Systems is available from the Materials and Tests Unit.

3.0 SURFACES

With the exception of cored slab bridges, apply the epoxy protective coating to the top surface area, including chamfer area, of bent caps under expansion joints and of end bent caps, excluding areas under elastomeric bearings. For cored slab bridges, do not apply the epoxy protective coating to the bent or end bent caps. Also, apply epoxy protective coating to the ends of prestressed concrete members as noted on the plans.

Use extreme care to keep the area under the elastomeric bearings free of the epoxy protective coating. Do not apply the epoxy protective coating in the notch at the ends of the prestressed concrete girders.

Thoroughly clean all dust, dirt, grease, oil, laitance, and other objectionable material from the concrete surfaces to be coated. Air-blast all surfaces immediately prior to applying the protective coating.

Only use cleaning agents pre-approved by the Engineer.

4.0 APPLICATION

Apply epoxy protective coating only when the air temperature is at least 40°F (4°C) and rising, but less than 95°F (35°C) and the surface temperature of the area to be coated is at least 40°F (4°C). Remove any excess or free standing water from the surfaces before applying the coating. Apply one coat of epoxy protective coating at a rate such that it covers between 100 and 200 ft²/gal (2.5 and 5 m²/liter).

Note: Under certain combinations of circumstances, the cured epoxy protective coating may develop “oily” condition on the surface due to amine blush. This condition is not detrimental to the applied system.

Apply the coating so that the entire designated surface of the concrete is covered and all pores filled. To provide a uniform appearance, use the exact same material on all visible surfaces.

5.0 BASIS OF PAYMENT

No separate measurement or payment will be made for preparing, furnishing and applying the epoxy protective coating to the concrete surfaces.

Payment at the contract unit prices for the various pay items will be full compensation for the above work including all materials, equipment, tools, labor, and incidentals necessary to complete the work.

ELASTOMERIC CONCRETE

(10-12-01)

1.0 DESCRIPTION

Elastomeric concrete is a mixture of a two-part polymer consisting of polyurethane and/or epoxy, and kiln-dried aggregate. Have the manufacturer supply it as a unit. Use the concrete in the blocked out areas on both sides of the bridge deck joints as indicated on the plans.

2.0 MATERIALS

Provide materials that comply with the following minimum requirements at 14 days.

CONCRETE PROPERTIES	TEST METHOD	MINIMUM REQUIREMENT
Bond Strength to Concrete, psi (MPa)	ASTM D638 (D638M)	450 (3.1)
Brittleness by Impact, ft-lb (kg-m)	Ball Drop	7 (0.97)
Compressive Strength, psi (MPa)	ASTM D695 (D695M)	2800 (19.3)

BINDER PROPERTIES (without aggregate)	TEST METHOD	MINIMUM REQUIREMENT
Tensile Strength, psi (MPa)	ASTM D638 (D638M)	800 (5.5)
Ultimate Elongation	ASTM D638 (D638M)	150%
Tear Resistance, lb/in (kN/m)	ASTM D624	90 (15.7)

In addition to the requirements above, use elastomeric concrete that also resists water, chemical, UV, and ozone exposure and withstands extreme temperature (freeze-thaw) changes.

Furnish a manufacturer's certification verifying that the materials satisfy the above requirements. Provide samples of elastomeric concrete to the Engineer, if requested, to independently verify conformance with the above requirements.

Require a manufacturer's representative to be present on site during the installation of the elastomeric concrete.

3.0 BASIS OF PAYMENT

No separate payment will be made for elastomeric concrete. The lump sum contract price bid for "Evazote Joint Seals" will be full compensation for furnishing and placing the Elastomeric Concrete.

VERTICAL CRACKS IN PRESTRESSED CONCRETE GIRDERS PRIOR TO DETENSIONING

(10-12-01)

Provide prestressed concrete girders without objectionable cracks. The provisions herein address prestressed concrete girders that have vertical casting cracks in the middle half of the member length prior to strand detensioning. Certain types of these cracks have been determined by the Department to render the girders unacceptable.

Unacceptable cracked members include, but are not limited to, those with two or more full height vertical cracks spaced at a distance less than the member depth. Such members are not considered serviceable and will be rejected. Full height cracks are cracks that begin at or near the top of the member and extend down to or below the center of gravity of the bottom group of prestressed strands.

Except as noted above, members with one or more vertical cracks that extend into the bottom flange are subject to an engineering assessment to determine their acceptability. If this engineering assessment requires, submit, at no additional cost to the Department, a proposal for repairing the member and a structural evaluation of the member prepared by a North Carolina Registered Professional Engineer. In the structural evaluation, consider the stresses under full service loads had the member not cracked and the effects of localized loss of prestress at the crack as determined by methods acceptable to the Department.

For members designed for zero tension under full service loads, the maximum magnitude of the computed concrete tension at the lower end of the cracks is the square root of the specified design strength of the concrete. The maximum width of the crack at the bottom of the web is 3 mils (0.075 mm) after detensioning. For all other members, the maximum magnitude of the computed concrete tension at the lower end of the crack is 350% of the square root of the

specified design strength of the concrete, and the maximum width of the crack at the bottom of the web is 4 mils (0.100 mm) after detensioning.

The Department has final determination regarding acceptability of any members in question.

FALSEWORK AND FORMWORK

(10-12-01)

1.0 DESCRIPTION

Use this Special Provision as a guide to develop temporary works submittals required by the Standard Specifications or other provisions; no additional submittals are required herein. Such temporary works include, but are not limited to, falsework and formwork.

Falsework is any temporary construction used to support the permanent structure until it becomes self-supporting. Formwork is the temporary structure or mold used to retain plastic or fluid concrete in its designated shape until it hardens. Access scaffolding is a temporary structure that functions as a work platform that supports construction personnel, materials, and tools, but is not intended to support the structure. Scaffolding systems that are used to temporarily support permanent structures (as opposed to functioning as work platforms) are considered to be falsework under the definitions given. Shoring is a component of falsework such as horizontal, vertical, or inclined support members. Where the term “temporary works” is used, it includes all of the temporary facilities used in bridge construction that do not become part of the permanent structure.

Design and construct safe and adequate temporary works that will support all loads imposed and provide the necessary rigidity to achieve the lines and grades shown on the plans in the final structure.

2.0 MATERIALS

Select materials suitable for temporary works; however, select materials that also ensure the safety and quality required by the design assumptions. The Engineer has authority to reject material on the basis of its condition, inappropriate use, safety, or nonconformance with the plans. Clearly identify allowable loads or stresses for all materials or manufactured devices on the plans. Revise the plan and notify the Engineer if any change to materials or material strengths is required.

3.0 DESIGN REQUIREMENTS

E. Working Drawings

Provide working drawings for items as specified in the contract, or as required by the Engineer, with design calculations and supporting data in sufficient detail to permit a structural and safety review of the proposed design of the temporary work.

When concrete placement is involved, include data such as the drawings of proposed sequence, rate of placement, direction of placement, and location of all construction joints. Submit the number of copies as called for by the contract.

When required, have the drawings and calculations prepared under the guidance of, and sealed by, a North Carolina Registered Professional Engineer who is knowledgeable in temporary works design.

Design falsework and formwork requiring submittals in accordance with the 1995 AASHTO *Guide Design Specifications for Bridge Temporary Works* except as noted herein.

1. Wind Loads

Table 2.2 of Article 2.2.5.1 is modified to include wind velocities up to 110 mph (177 km/hr). In addition, Table 2.2A is included to provide the maximum wind speeds by county in North Carolina.

Table 2.2 - Wind Pressure Values

Height Zone feet (m) above ground	Pressure, lb/ft ² (kPa) for Indicated Wind Velocity, mph (km/hr)				
	70 (112.7)	80 (128.7)	90 (144.8)	100 (160.9)	110 (177.0)
0 to 30 (0 to 9.1)	15 (0.72)	20 (0.96)	25 (1.20)	30 (1.44)	35 (1.68)
30 to 50 (9.1 to 15.2)	20 (0.96)	25 (1.20)	30 (1.44)	35 (1.68)	40 (1.92)
50 to 100 (15.2 to 30.5)	25 (1.20)	30 (1.44)	35 (1.68)	40 (1.92)	45 (2.15)
over 100 (30.5)	30 (1.44)	35 (1.68)	40 (1.92)	45 (2.15)	50 (2.39)

2. Time of Removal

The following requirements replace those of Article 3.4.8.2.

Do not remove forms until the concrete has attained strengths required in Article 420-17 of the Standard Specifications and these Special Provisions.

Do not remove forms until the concrete has sufficient strength to prevent damage to the surface.

Table 2.2A - Steady State Maximum Wind Speeds by Counties in North Carolina

COUNTY	25 YR (mph) (km/hr)	COUNTY	25 YR (mph) (km/hr)	COUNTY	25 YR (mph) (km/hr)
Alamance	70 (112.7)	Franklin	70 (112.7)	Pamlico	100 (160.9)
Alexander	70 (112.7)	Gaston	70 (112.7)	Pasquotank	100 (160.9)
Alleghany	70 (112.7)	Gates	90 (144.8)	Pender	100 (160.9)
Anson	70 (112.7)	Graham	80 (128.7)	Perquimans	100 (160.9)
Ashe	70 (112.7)	Granville	70 (112.7)	Person	70 (112.7)
Avery	70 (112.7)	Greene	80 (128.7)	Pitt	90 (144.8)
Beaufort	100 (160.9)	Guilford	70 (112.7)	Polk	80 (128.7)
Bertie	90 (144.8)	Halifax	80 (128.7)	Randolph	70 (112.7)
Bladen	90 (144.8)	Harnett	70 (112.7)	Richmond	70 (112.7)
Brunswick	100 (160.9)	Haywood	80 (128.7)	Robeson	80 (128.7)
Buncombe	80 (128.7)	Henderson	80 (128.7)	Rockingham	70 (112.7)
Burke	70 (112.7)	Hertford	90 (144.8)	Rowan	70 (112.7)
Cabarrus	70 (112.7)	Hoke	70 (112.7)	Rutherford	70 (112.7)
Caldwell	70 (112.7)	Hyde	110 (177.0)	Sampson	90 (144.8)
Camden	100 (160.9)	Iredell	70 (112.7)	Scotland	70 (112.7)
Carteret	110 (177.0)	Jackson	80 (128.7)	Stanley	70 (112.7)
Caswell	70 (112.7)	Johnston	80 (128.7)	Stokes	70 (112.7)
Catawba	70 (112.7)	Jones	100 (160.9)	Surry	70 (112.7)
Cherokee	80 (128.7)	Lee	70 (112.7)	Swain	80 (128.7)
Chatham	70 (112.7)	Lenoir	90 (144.8)	Transylvania	80 (128.7)
Chowan	90 (144.8)	Lincoln	70 (112.7)	Tyrell	100 (160.9)
Clay	80 (128.7)	Macon	80 (128.7)	Union	70 (112.7)
Cleveland	70 (112.7)	Madison	80 (128.7)	Vance	70 (112.7)
Columbus	90 (144.8)	Martin	90 (144.8)	Wake	70 (112.7)
Craven	100 (160.9)	McDowell	70 (112.7)	Warren	70 (112.7)
Cumberland	80 (128.7)	Mecklenburg	70 (112.7)	Washington	100 (160.9)
Currituck	100 (160.9)	Mitchell	70 (112.7)	Watauga	70 (112.7)
Dare	110 (177.0)	Montgomery	70(112.7)	Wayne	80 (128.7)
Davidson	70 (112.7)	Moore	70 (112.7)	Wilkes	70 (112.7)
Davie	70 (112.7)	Nash	80 (128.7)	Wilson	80 (128.7)
Duplin	90 (144.8)	New Hanover	100 (160.9)	Yadkin	70 (112.7)
Durham	70 (112.7)	Northampton	80 (128.7)	Yancey	70 (112.7)
Edgecombe	80 (128.7)	Onslow	100 (160.9)		
Forsyth	70 (112.7)	Orange	70 (112.7)		

Note on the working drawings any anchorages, connectors, inserts, steel sleeves or other such devices used as part of the falsework or formwork that remains in the permanent structure. If the plan notes indicate that the structure contains the necessary corrosion protection required for a Corrosive Site, epoxy coat, galvanize, metallize or otherwise protect these devices as directed by the Engineer. Any coating required by the Engineer will be considered incidental to the various pay items requiring temporary works.

F. Review and Approval

The Engineer is responsible for the review and approval of temporary works' drawings.

Submit the working drawings sufficiently in advance of proposed use to allow for their review, revision (if needed), and approval without delay to the work.

Do not start construction of any temporary work for which working drawings are required until the drawings have been approved. Such approval does not relieve the Contractor of the responsibility for the accuracy and adequacy of the working drawings.

The time period for review of the working drawings does not begin until complete drawings and design calculations, when required, are received by the Engineer.

On the drawings, show all information necessary to allow the design of any component to be checked independently as determined by the Engineer.

If requested by the Engineer, submit with the working drawings manufacturer's catalog data listing the weight of all construction equipment that will be supported on the temporary work. Show anticipated total settlements and/or deflections of falsework and forms on the working drawings. Include falsework footing settlements, joint take-up, and deflection of beams or girders. Design the falsework and forms supporting deck slabs and overhangs on girder bridges so that there will be no differential settlement between the girders and the deck forms during placement of deck concrete.

4.0 CONSTRUCTION REQUIREMENTS

All requirements of Section 420 of the Standard Specifications apply.

Construct temporary works in conformance with the approved working drawings. Ensure that the quality of materials and workmanship employed is consistent with that assumed in the design of the temporary works. Do not weld falsework members to any portion of the permanent structure unless approved. Show any welding to the permanent structure on the approved construction drawings.

Provide tell-tales attached to the forms and extending to the ground, or other means, for accurate measurement of falsework settlement. Make sure that the anticipated compressive settlement and/or deflection of falsework does not exceed 1 inch (25 mm). For cast-in-place concrete structures, make sure that the calculated deflection of falsework

flexural members does not exceed $1/240$ of their span regardless of whether or not the deflection is compensated by camber strips.

G. Maintenance and Inspection

Inspect and maintain the temporary work in an acceptable condition throughout the period of its use. Certify that the manufactured devices have been maintained in a condition to allow them to safely carry their rated loads. Clearly mark each piece so that its capacity can be readily determined at the job site.

Perform an in-depth inspection of an applicable portion(s) of the temporary works, in the presence of the Engineer, not more than 24 hours prior to the beginning of each concrete placement. Inspect other temporary works at least once a month to ensure that they are functioning properly. Have a North Carolina Registered Professional Engineer inspect the cofferdams, shoring, sheathing, support of excavation structures, and support systems for load tests prior to loading.

H. Foundations

Determine the safe bearing capacity of the foundation material on which the supports for temporary works rest. If required by the Engineer, conduct load tests to verify proposed bearing capacity values that are marginal or in other high-risk situations.

The use of the foundation support values shown on the contract plans of the permanent structure is permitted if the foundations are on the same level and on the same soil as those of the permanent structure.

Allow for adequate site drainage or soil protection to prevent soil saturation and washout of the soil supporting the temporary works supports.

If piles are used, the estimation of capacities and later confirmation during construction using standard procedures based on the driving characteristics of the pile is permitted. If preferred, use load tests to confirm the estimated capacities; or, if required by the Engineer conduct load tests to verify bearing capacity values that are marginal or in other high risk situations.

The Engineer reviews and approves the proposed pile and soil bearing capacities.

5.0 REMOVAL

Unless otherwise permitted, remove and keep all temporary works upon completion of the work. Do not disturb or otherwise damage the finished work.

Remove temporary works in conformance with the contract documents. Remove them in such a manner as to permit the structure to uniformly and gradually take the stresses due to its own weight.

6.0 METHOD OF MEASUREMENT

Unless otherwise specified, temporary works will not be directly measured.

7.0 BASIS OF PAYMENT

Payment at the contract unit prices for the various pay items requiring temporary works will be full compensation for the above falsework and formwork.

SUBMITTAL OF WORKING DRAWINGS**(8-13-04)****1.0 GENERAL**

Submit working drawings in accordance with Article 105-2 of the Standard Specifications and the requirements of this Special Provision. The list of submittals contained herein does not represent a list of required submittals for this project. Submittals are only necessary for those items as required by the Standard Specifications, other Special Provisions, or contract plans. Make submittals that are not specifically noted in this Special Provision directly to the Resident Engineer.

If submittals contain variations from plan details or specifications, significantly affect project cost, or significantly affect field construction or operations, discuss them with, and submit them through, the Resident Engineer. State the reason for the proposed variation in the submittals. To minimize overall review time, make sure all working drawing submittals are complete when first submitted. Provide a contact name and phone number with each submittal. Direct any questions regarding working drawing submittal requirements to the Resident Engineer, Structure Design Unit contacts or the Geotechnical Engineering Unit contacts noted below.

2.0 WORKING DRAWINGS SUBMITTAL CONTACTS

All submittals noted herein are reviewed by the Structure Design Unit and/or the Geotechnical Engineering Unit.

For submittals to the Structure Design Unit, use the following addresses:

Via US mail:

Mr. G. R. Perfetti, P. E.
 State Bridge Design Engineer
 North Carolina Department
 of Transportation
 Structure Design Unit
 1581 Mail Service Center
 Raleigh, NC 27699-1581
 Attention: Mr. P. D. Lambert, P. E.

Via other delivery service:

Mr. G. R. Perfetti, P. E.
 State Bridge Design Engineer
 North Carolina Department
 of Transportation
 Structure Design Unit
 1000 Birch Ridge Drive
 Raleigh, NC 27610
 Attention: Mr. P. D. Lambert, P. E.

For submittals to the Geotechnical Engineering Unit, use the following addresses:

For projects in Divisions 1-7, use the following Eastern Regional Office address:

Via US mail:

Mr. K. J. Kim, Ph. D., P. E.
Eastern Regional Geotechnical
Manager
North Carolina Department
of Transportation
Geotechnical Engineering Unit
Eastern Regional Office
1570 Mail Service Center
Raleigh, NC 27699-1570

Via other delivery service:

Mr. K. J. Kim, Ph. D., P. E.
Eastern Regional Geotechnical
Manager
North Carolina Department
of Transportation
Geotechnical Engineering Unit
Eastern Regional Office
3301 Jones Sausage Road, Suite 100
Garner, NC 27529

For projects in Divisions 8-14, use the following Western Regional Office address:

Via US mail:

Mr. John Pilipchuk, L. G., P. E.
Western Regional Geotechnical
Manager
North Carolina Department
of Transportation
Geotechnical Engineering Unit
Western Regional Office
5253 Z Max Boulevard
Harrisburg, NC 28075

Via other delivery service:

Mr. John Pilipchuk, L. G., P. E.
Western Region Geotechnical
Manager
North Carolina Department
of Transportation
Geotechnical Engineering Unit
Western Regional Office
5253 Z Max Boulevard
Harrisburg, NC 28075

Direct any questions concerning submittal review status, review comments, or drawing markups to the following contacts:

Primary Structures Contact:

Paul Lambert
(919) 250 – 4041
(919) 250 – 4082 facsimile
plambert@dot.state.nc.us

Secondary Structures Contacts:

James Gaither (919) 250 – 4042
Man-Pan Hui (919) 250 – 4044

Eastern Regional Geotechnical Contact (Divisions 1-7):

K. J. Kim
(919) 662 – 4710
(919) 662 – 3095 facsimile
kkim@dot.state.nc.us

Western Regional Geotechnical Contact (Divisions 8-14):

John Pilipchuk
(704) 455 – 8902
(704) 455 – 8912 facsimile
jpilipchuk@dot.state.nc.us

3.0 SUBMITTAL COPIES

The quantities provided in this Special Provision act as a guide in the submittal process.

Unless otherwise required by the contract, submit two sets of supporting calculations to the Structure Design Unit.

Furnish one complete copy of the submittal, including all attachments, to the Resident Engineer. If requested, provide additional copies of any submittal. At the same time, submit the following number of copies directly to the Structure Design Unit and/or the Geotechnical Engineering Unit:

Working Drawing Submittal	Copies Required by Structure Design Unit	Copies Required by Geotechnical Engineering Unit	Contract Reference Requiring Submittal ¹
Arch Culvert Falsework	5	0	Plan Note & SN Sheet
Box Culvert Falsework ²	5	0	Plan Note & SN Sheet
Cofferdams ⁴	6	1	Articles 410-5 and 420-8
Expansion Joint Seals (hold down plate type with base angle)	9	0	“Expansion Joint Seals”
Expansion Joint Seals (modular)	2, then 9	0	“Modular Expansion Joint Seals”
Expansion Joint Seals (strip seals)	9	0	“Strip Seals”
Falsework & Forms (superstructure)	8	0	Article 420-3
Falsework & Forms ² (substructure)	8	0	Article 420-3
Mechanically Stabilized Earth Retaining Walls ⁴	7	1	“MSE Retaining Walls”
Metal Bridge Railing	8	0	Plan Note
Metal Stay-in-Place Forms	8	0	Article 420-3
Metalwork for Elastomeric Bearings ^{5,6}	7	0	Article 1072-10
Miscellaneous Metalwork ^{5,6}	7	0	Article 1072-10
Overhead Sign Assemblies	13	0	Article 903-3(C)
Pile Points	7	1	Article 450-8(D) & “Steel Pile Points”
Placement of Equipment on Structures (cranes, etc.)	7	0	Article 420-20

Precast Concrete Box Culverts	2, then 1 reproducible	0	“(Optional) Precast Reinforced Concrete Box Culvert at Station ____”
Precast Retaining Wall Panels	10	0	Article 1077-2
Pot bearings ⁵	8	0	“Pot Bearings”
Prestressed Concrete Deck Panels	6 and 1 reproducible	0	Article 420-3
Proprietary retaining walls ⁴	9	1	Applicable Project Special Provision
Prestressed Concrete Girder (strand elongation and detensioning sequences)	6	0	Articles 1078-8 and 1078-11
Prestressed Concrete Cored Slab (detensioning sequences) ³	6	0	Article 1078-11
Revised Bridge Deck Plans (adaptation to metal stay-in-place forms)	2, then 1 reproducible	0	Article 420-3
Revised Bridge Deck Plans (adaptation to modular expansion joint seals)	2, then 1 reproducible	0	“Modular Expansion Joint Seals”
Soil Nail Retaining Walls ⁴	4	1	Applicable Project Special Provision
Sound Barrier Wall Steel Fabrication Plans ⁶	7	0	Article 1072-10 & “Sound Barrier Wall”
Sound Barrier Wall Casting Plans	10	0	Article 1077-2 & “Sound Barrier Wall”
Structural Steel ⁵	2, then 7	0	Article 1072-10
TFE Expansion Bearings ⁵	8	0	Article 1072-10
Temporary Detour Structures ⁴	10	1	Article 400-3 & “Construction, Maintenance and Removal of Temporary Structure at Station ____”
Temporary Shoring ⁴	6	1	Article 410-4 & “Temporary Shoring for Maintenance of Traffic”

Temporary Fabric or Wire Walls ⁸	0	2	Applicable Project Special Provision
Permanent Anchored Tieback Retaining Walls ⁴	4	1	Applicable Project Special Provision
Evazote Joint Seals ⁷	9	0	Applicable Project Special Provision
Optional Disc Bearings ⁵	8	0	“Optional Disc Bearings”
Removal of Existing Structure over Railroad	5	0	Railroad Special Provisions
Drilled Pier Construction Sequence Plans ⁸	0	2	“Drilled Piers”
Pile Hammers ⁸	0	2	Article 450-6

FOOTNOTES

1. References are provided to help locate the part of the contract where the working drawing submittals are required. References in quotes refer to the Project Special Provision by that name. Articles refer to the Standard Specifications.
2. Submittals for these items are necessary only when plan notes require them.
3. Submittals for these items may not be required. A list of pre-approved sequences is available from the producer or the Materials and Tests Unit.
4. These submittals are reviewed by the Structure Design Unit and the Geotechnical Engineering Unit. If NCDOT Shoring Standards are used, working drawings need not be submitted, but the Shoring Selection Form should be forwarded to the Geotechnical Engineering Unit.
5. The fabricator may submit these items directly to the Structure Design Unit.
6. The two sets of preliminary submittals required by Article 1072-10 of the Standard Specifications are not required for these items.
7. Submittals for Fabrication Drawings are not required. Submission of Catalogue Cuts of Proposed Material is required. See Section 5.A of the Project Special Provision.
8. Submittals for these items are reviewed by the Geotechnical Engineering Unit only and correspondence regarding these items should be directed to and will come from the Geotechnical Engineering Unit.

**CONSTRUCTION, MAINTENANCE AND REMOVAL
OF TEMPORARY ACCESS AT STATION 12+21.750 -L- & 11+03.000 -Y1-**

(2-14-04)

1.0 GENERAL

Construct, maintain, and remove the temporary access required to provide the working area necessary to construct the bridge and, if applicable, remove an existing bridge. Temporary access may include other methods than those outlined in this Special Provision; however, all types of temporary access are required to meet the requirements of all permits, the Standard Specifications, and this Special Provision.

2.0 TEMPORARY ROCK CAUSEWAY [WORKPAD]

If detailed on the plans, construction of a temporary rock causeway [workpad] within the limits shown on the plans is permitted. Build the causeway [workpad] with Class II riprap topped by a layer of Class A riprap or as otherwise designated on the plans or approved by the Engineer. If desired, recycle the Class II riprap used in the causeway [workpad] for placement in the final riprap slope protection as directed by the Engineer. No payment will be made for recycled riprap as this material is considered incidental to the causeway [workpad] placement and removal. If this option is exercised, no adjustment in contract bid price will be allowed due to an underrun in the quantity of "Plain Rip Rap Class II (2'-0" (600 mm) Thick)".

Completely remove all causeway [workpad] material including pipes and return the entire causeway [workpad] footprint to the original contours and elevations within 90 days of the completion of the deck slab or as otherwise required by permits.

For sites affected by moratoriums of restrictions on in-stream work: Do not construct or remove causeway [workpad] during the moratorium period shown on the permit. If the completion of the deck slab falls within the prohibitive dates for causeway [workpad] construction or removal, begin causeway [workpad] removal immediately following the prohibitive dates.

3.0 TEMPORARY WORK BRIDGE

If noted on the plans, the construction of a temporary work bridge is permitted. Submit details of the temporary work bridge to the Engineer prior to constructing the work bridge to ensure conformance with the plans and all permits. Make certain that the temporary work bridge satisfies all permits. Completely remove the temporary bridge prior to final acceptance or as otherwise required by the permits.

If a causeway [workpad] is detailed on the plans, the construction of a temporary work bridge in lieu of the causeway [workpad] is permitted. If this option is exercised, prepare all necessary documents required for permit modifications, if any.

4.0 BASIS OF PAYMENT

The lump sum price bid for “Construction, Maintenance and Removal of Temporary Access at Station 12+21.750 -L- & 11+03.000 -Y1-” will be full compensation for the above work, or other methods of access, including all material, pipes, work bridge components, equipment, tools, labor, disposal, and incidentals necessary to complete the work.

METRIC STRUCTURAL STEEL**(10-12-01)**

The structural steel for this project is specified in SI (Metric) units with plate thickness designated in millimeters in accordance with AASHTO M160M.

The substitution of structural steel in US Customary nominal thickness is permitted for primary and secondary members defined as follows:

- Primary members - members such as webs and flanges of plate girders, transverse and bearing stiffeners, girder field splice plates, and connector plates for curved girders.
- Secondary members - members such as connector plates for straight girders, bearing plates and miscellaneous hardware.

Such substitution is limited to the values shown in the following table.

Material Specified Metric (mm)	Primary Members US Customary (in)	Secondary Members US Customary (in)
8	3/8	*
9	3/8	*
10	7/16	3/8
11	7/16	*
12	1/2	*
14	9/16	*
16	11/16	5/8
18	3/4	11/16
20	13/16	3/4
22	7/8	*
25	1	*
28	1-1/8	*
30	1-3/16	*
32	1-5/16	1-1/4
35	1-7/16	1-3/8
38	1-1/2	*
40	1-5/8	*
45	1-13/16	*
50	2	*
55	2-1/4	*
60	2-3/8	*
70	2-13/16	2-3/4
* These values are the same as those for Primary members.		

There will be no additional payment for any extra weight incurred as a result of any substitution.

ELASTOMERIC BEARINGS

(10-03-02)

Use elastomeric bearings in accordance with Article 1079-2 of the Standard Specifications except as follows:

**TABLE 1079-2
NATURAL RUBBER ELASTOMER REQUIREMENTS**

Grade (durometer)	50	60
PHYSICAL PROPERTIES		
Hardness ASTM D2240	50 +5 -5	60 +5 -5

UNCLASSIFIED STRUCTURE EXCAVATION AT STATION 12+21.7450 -L- & 11+03.000 -Y1-

(12-12-02)

The 2002 Standard Specifications shall be revised as follows:

Unclassified structure excavation shall be in accordance with Section 412 of the Standard Specifications with the following exception:

Payment will be made under:

Unclassified Structure Excavation at Station _____Lump Sum

PRESTRESSED CONCRETE MEMBERS

(2-14-04)

In Section 1078-12 of the Standard Specifications after the first sentence of “5,” place the following:

“Conduit may be rigid one-piece or rigid two-piece (split sheathed). Do not use flexible conduit.”

In Section 1078-13 of the Standard Specifications, after the fourth paragraph add the following paragraph:

“When handling the prestressed concrete members, a temporary stress of $5\sqrt{f_{ci}}$ is permitted, where f_{ci} is the strength of concrete at release, in psi.”

In Section 1078-5 of the Standard Specifications, place the following two sentences after the first paragraph:

“When casting holes through the top flange of Bulb Tee Girders for overhang or interior bay falsework hanger rods use rigid PVC conduits with a wall thickness of approximately 1/8 inch. Do not use thin wall material. Secure conduits in the forms so that they do not migrate out of the proper location. Other methods of forming holes may be proposed but are subject to the Engineer’s approval.”

“When casting dowel rod holes in cored slab members use material that creates round, vertical holes of the specified diameter and in the correct location. Do not use material that deforms, collapses or shifts position during casting of the member.”

FABRICATED METAL STAY IN PLACE FORMS

(8-13-04)

In Section 420-3 “Falsework and Forms” of the Standard Specifications, revise “(D)(2) Fabricated Metal Stay-In-Place Forms” as follows:

Add the following sentence after the third sentence of the first paragraph:

When required by the design plans, detail SIP forms with excluder plates to exclude concrete from the valleys in the forms. Do not use filler material, such as styrofoam, in the form valleys.

and add the following new Item, (D)(10) Fabricated Metal Stay-In-Place Forms

10. Weld metal stay-in-place forms for prestressed concrete girders to embedded clips in the girder flanges. . The embedded clips shall be a minimum of 2" x 3¼" (51 mm x 83 mm) and 2" (51 mm) long. The clips shall be galvanized, 12 gauge ASTM A653 steel and have a ¾" (19 mm) or 1" (25 mm) diameter hole in the 2" (51 mm) leg. The spacing of the clips shall be 12" (305 mm). All submitted metal stay-in-place form designs must be able to utilize the standard size and spacing of the clip described above.

CONCRETE WEARING SURFACE

(SPECIAL)

1.0 GENERAL

This Special Provision governs materials, forming and all other related work in the construction of a concrete wearing surface in accordance with applicable parts of the Standard Specifications, the details shown on the plan, and as outlined in these Special Provisions.

2.0 MATERIALS

Unless otherwise noted on the plans, use class AA concrete containing glass fibers and a coarse aggregate gradation of 78M. Provide approved glass fibers at a dosage rate recommended by the Manufacturer. The Class AA concrete shall contain fly ash or ground granulated blast furnace slag at the substitution rate specified in Article 1024-1 and in accordance with Articles 1024-5 and 1024-6 of the Standard Specifications.

3.0 PREPARATION OF SURFACE

Completely clean all surfaces within the 48 hours prior to placing the overlay unless otherwise approved.

Thoroughly soak the cleaned surface for at least 12 hours prior to placing the concrete wearing surface. While soaking the surface, cover it with a layer of white opaque polyethylene film that is at least 4 mils (0.100 mm) thick. Immediately prior to placing the concrete wearing surface, remove standing water from the surface.

4.0 EQUIPMENT

Prior to beginning any work, obtain approval for all equipment to be used for deck preparation, placing, finishing, and curing the concrete wearing surface.

For surface preparation, use sandblasting or pressure washing equipment capable of removing all foreign matter. If using high pressure water blast, a minimum nozzle pressure of 3000 psi is required.

5.0 PLACING AND FINISHING

Follow the placing, finishing, and curing requirements of Article 420-15 (A) and (B). Construction Joints other than those shown on the plans are not permitted.

6.0 LIMITATIONS OF OPERATIONS

Vehicles and construction equipment are not permitted on the finished concrete wearing surface until the seven day curing time is completed and the concrete reaches the minimum specified compressive strength.

Use insulation that meets the requirements of Article 420-9(c), and if required, place it on the concrete wearing surface as soon as the initial set permits.

7.0 METHOD OF MEASUREMENT

The quantity of concrete wearing surface to be paid for is the actual number of square meters of concrete wearing surface as provided on the plans.

8.0 BASIS OF PAYMENT

The quantity for which payment is made will be that quantity shown in square meters on the plans. Where the plans have been revised, the quantity to be paid for will be the quantity shown on the revised plans.

The unit bid per square meter will be full compensation for all work covered by this Special Provision and applicable parts of the Standard Specifications, but not limited to furnishing and placing concrete, joint filler and sealer, deck drains, bridge scuppers, and any other material; erecting and removing all forms, curing concrete, protecting concrete in wind, rain, low humidity, high temperatures or other unfavorable weather;

Payment will be made under:
Concrete Wearing SurfaceSquare Meter

PRESTRESSED CONCRETE BOX BEAM (SPECIAL)

The prestressed box beam members shall meet the requirements for prestressed concrete members as specified in the Standard Specifications with the following exceptions and additions.

1.0 FABRICATION

Place concrete for box beams in 2 or more horizontal layers. Place and compact each layer before the preceding layer takes initial set so that there is no surface or separation between layers. Should shrinkage or settlement cracks occur, the Engineer reserves the right to require additional layers and/or vibration.

The requirements of the above paragraph may be waived if self-consolidating concrete is used.

When box beams are cast, a positive hold-down system shall be employed to prevent voids from moving. Design the system to be left in place until the concrete has reached the release strength. At least six weeks prior to casting box beams, the Contractor shall submit to the Engineer for review and comment, detailed drawings of the proposed void material and hold-down system. In addition to structural details, location and spacing of the hold-downs shall be indicated. The Contractor shall also submit his proposed method of concrete placement and of consolidating the concrete under the void. Cutting or drilling holes in the void material for the purposes of providing access for consolidating equipment will not be permitted.

Rake the top surface of the box beam section to a depth of 3/8" (10 mm). No surface finish is required for sides and bottom of the box beam sections except the exposed side of the exterior beam section as noted below. Provide a resulting surface finish essentially the same color and surface finish as the surrounding concrete. Fill all voids in the outside face of exterior box beams with a sand-cement or other approved grout. Repair voids greater than 1/4" (6 mm) in diameter or depth in other faces of the box beams in a like manner. Where an excessive number of smaller voids exist in any member, the Engineer requires a similar repair.

Provide a 3/4" (19 mm) chamfer along the bottom edges on ends and sides of all beam sections, top outside edges of exterior beam sections and acute corners of beam sections. Round the top edges on ends of all sections with a 1/4" (6 mm) finishing tool. Provide square corners along top edges on all slab sections along shear keys. Do not chamfer vertical edges at ends of beam sections.

2.0 ALIGNMENT AND DIRECTIONAL TOLERANCES

In order to ensure a good, neat field fit, assemble box beam spans in the yard and have pieces match-marked. Ensure that pieces fit together neatly and in a workman-like manner.

Manufacture the box beams within the tolerances listed in the "Box Beam Tolerances" table and sketches.

3.0 ERECTION

The post tensioning system shall use 0.6" (15mm) diameter strands or 1" (25mm) diameter steel bars. Steel bars shall have a minimum yield strength of 150,000 psi (1034.2 MPa), meeting the requirements of ASTM A722. Strands shall be tensioned to 43,950 pounds (195.5 kN) and bars shall be tensioned to 90,000 pounds (400 kN), and shall not exceed 80% of yield strength. Strands shall be placed in a non-corrosive 0.6" (15mm) diameter, 1/16" (1.6mm) minimum wall thickness black polyethylene pipe meeting the requirements of ASTM D2239. Similarly, bars shall be placed in a 1" (25mm) diameter black polyethylene pipe.

When erecting prestressed box beams, place the transverse post tensioning system in the diaphragms, place grout in the grout pockets located at the areas of the post tensioning strands, if provided, and tension to the required force. Grease the bars or strands and place in the polyethylene pipe. Do not apply grease or extend the pipe in the area of the recesses at the ends of the tensioning strands where grout is applied. Tension the bars or strands in the diaphragm nearest mid-span first. Proceed to tension bars or strands in the adjacent diaphragms. Continue the tensioning operation in a symmetric manner along the length of the span. At each diaphragm location, maintain a symmetric tension force between each pair of bars or strands in the diaphragm. After all tensioning in a span is completed and before placing any equipment, material or barrier rail on the span, fill the shear key, dowel holes, and recesses at the ends of the diaphragm with an approved non-metallic, non-shrink grout. Cure for 3 days minimum and until the grout reaches a compressive strength of 3000 psi (20.7 MPa).

After tensioning and curing, obtain approval prior to placing material and equipment on the box beam spans. Support cranes or other equipment exceeding the legal load limit on mats. Submit for review a detailed drawing for the mats that are intended for use on the box beams. Provide a complete description of the equipment that is intended for placement on the mats. Supply and construct mats at no additional cost to the Department.

4.0 PAYMENT

The quantity of prestressed concrete box beams shown on the plans will be paid for at the contract unit price per linear foot for "914 x 838 Prestressed Concrete Box Beams." This price and payment shall be full compensation for furnishing and placing the prestressed concrete box beams and includes all materials, tools, equipment, labor and incidentals necessary to complete this work.

BOX BEAM TOLERANCES:

a = Length: ± 1 in.

b = Width (overall): $\pm \frac{1}{4}$ in.

c = Depth (overall): $\pm \frac{1}{4}$ in.

d = Variation from specified plan end squareness or skew:

$\pm \frac{1}{8}$ in. per 12 in. width, $\pm \frac{1}{2}$ in. max.

e = Variation from specified elevation end squareness or skew:

$\pm \frac{1}{8}$ in. per 12 in., $\pm \frac{1}{2}$ in. max.

f = Sweep, for member length:

up to 40 ft. $\pm \frac{1}{4}$ in.

40 to 60 ft. $\pm \frac{3}{8}$ in.

greater than 60 ft. $\pm \frac{1}{2}$ in.

g = Differential camber between adjacent members:

$\frac{1}{4}$ in. per 10 ft., $\frac{3}{4}$ in. max.

h = Local smoothness of any surface: $\frac{1}{4}$ in. in 10 ft.

k = Position of strands: $\pm \frac{1}{4}$ in.

n = Longitudinal Position of blockout: ± 1 in.

o_1 = Position of dowel holes: $\pm \frac{1}{4}$ "

o_2 = Position of sleeves cast in beams, in both horizontal and vertical plane: $\pm \frac{1}{2}$ in.

p = Position of void: $\pm \frac{3}{8}$ "

Bearing area – deviation from plane surface: $\pm \frac{1}{16}$ "

Width of any one span = Plan width + $\frac{1}{8}$ " per joint

Box Beam Tolerances:

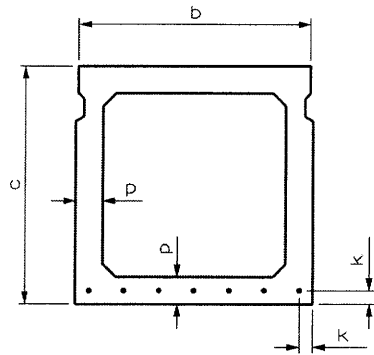

CROSS SECTION

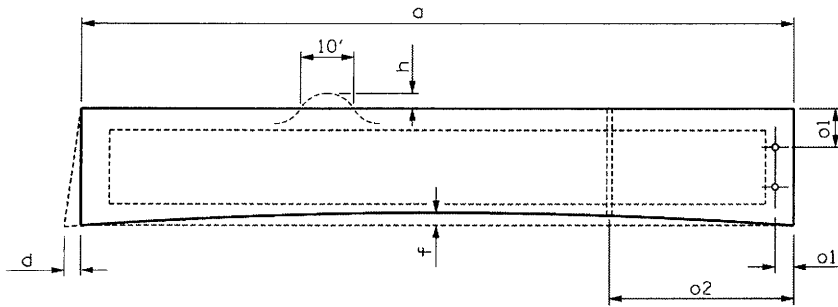

PLAN

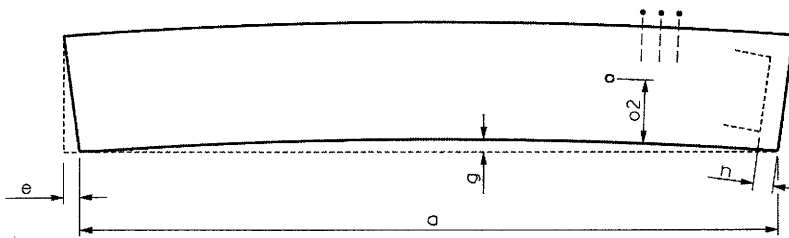

ELEVATION

CLASSIC CONCRETE BRIDGE RAILS:**(SPECIAL)****1.0 General**

The "Classic Concrete Bridge Rail" shall be in accordance with applicable parts of the Standard Specifications, the details shown on the plans and as outlined in these special provisions. Plans for the bridge rails are detailed for cast in place concrete and must be placed using conventional forms.

2.0 Concrete Mix

Concrete for the bridge rail shall meet the requirements for class AA concrete with exception noted below:

The maximum size coarse aggregate used in the concrete mix shall be #78M. The slump shall be within the range of 125mm to 200mm when tested in accordance with AASHTO T119. A high range water reducer shall be used. The quantity of high range water reducer per pound of cement shall be within the range recommended on the current list of approved admixtures issued by M&T Unit.

3.0 Construction

The bridge rails shall be placed to the established shape, line, grade and dimensions shown on the plans.

Joints in the rails shall be constructed at the locations and of the type specified on the plans.

4.0 Finishing

All exposed surfaces which are not satisfactory to the Engineer as to uniformity of color and texture or because of excessive patching shall be corrected as required by the Engineer. The roadway face of the bridge rails shall be given a Class II surface finish in accordance with the Standard Specifications unless directed otherwise by the Engineer.

5.0 Payment

The quantity for which payment is made will be that quantity shown in meters on the plans for "Classic Concrete Bridge Rail." This price and payment shall be full compensation for all materials, admixtures, forms, falsework, curing, surface finish, tools, labor, equipment and incidentals necessary to complete the item.

FOOTING, RAIL & SIDEWALK BETWEEN STRUCTURES: (SPECIAL)

The "Footing, Rail & Sidewalk between Structures" shall be in accordance with applicable parts of the Standard Specifications and the details shown on the plans.

Payment for Footing, Rail & Sidewalk between Structures will be at the Lump Sum contract price bid for "Footing, Rail & Sidewalk between Structures." This price and payment shall be full compensation for all materials including compacted ABC, labor, equipment and incidentals necessary to complete the item.

Payment will be made under:

Footing, Rail & Sidewalk between Structures.....Lump Sum

PROJECT SPECIAL PROVISIONS
ELECTRICAL CONDUIT SYSTEM

September 27, 2004

DESCRIPTION:

The work covered by this section consists of furnishing and installing a conduit system embedded in bridge rails, for light standards to be installed by others. Perform all work in accordance with these special provisions, the plans, the National Electrical Code (NEC), and Division 14 of the North Carolina Department of Transportation "Standard Specifications for Roads and Structures."

The Contractor actually performing the work described in these special provisions shall have a license of the proper classification from the North Carolina State Board of Examiners of Electrical Contractors.

The licensed Electrical Contractor must be available on the job site when the work is being performed or when requested by the Engineer. The licensed Electrical Contractor shall have a set of plans and special provisions in his possession on the job site, and must maintain accurate "as built" plans.

MATERIALS

Submit eight (8) copies of catalog cuts and/or drawings for all proposed materials for the Engineer's review and approval. Include the brand name, stock number, description, size, rating, manufacturing specification, and applicable contract item number(s) on each submittal. Allow forty (40) days for submittal review. The Engineer will advise the Contractor of reasons for rejected submittals and will return approved submittals to the Contractor. Do not deliver material to the project prior to submittal approval.

Conduit shall be non-metallic, rigid PVC (Polyvinyl chloride), Schedule 40, approved for above ground and underground use without concrete encasement per U.L. 651 "Rigid Non-Metallic Conduit". Use Terminations designed for PVC conduit, to seal and stub out each PVC conduit, and to provide watertight protection.

Provide expansion fittings of the appropriate size as noted in the plans. Expansion fittings shall be weatherproof, designed for Schedule 40 (1 1/2") PVC conduit and provide 100mm (4") minimum of conduit movement.

Type BR junction box shall be cast iron, hot-dipped galvanized with external recess flange for flush mounting sized as shown on the plans. It shall have a neoprene gasketed cover with brass or stainless steel screws and shall be suitable for a watertight installation. A mounting button with a blind tapped bolt hole shall be provided on the interior for future connection of a grounding lug. The junction box shall have a replaceable flange and checkered cover made to withstand pedestrian and light vehicular traffic. The flanges and covers shall be a standardized design so that replacement can be done without disturbing the box or conduit system. Provide

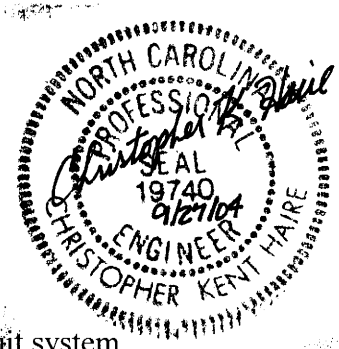

pull lines specifically designed for pulling rope through conduit. Use pull lines made of 2-ply line, with a tensile strength of 109kg (240 pounds) minimum. Use rot and mildew resistant pull lines that are resistant to tangling when being dispensed.

Use mastic that is a permanent, non-hardening, water sealing compound that adheres to metal, plastic, and concrete.

Provide zinc rich paint conforming to Section 1080-9 of the Standard Specifications.

The Town will provide light standard anchor bolts.

CONSTRUCTION METHODS

All conduit and boxes shall be securely fastened with ties prior to placing any concrete. After the conduit is encased in concrete, the Contractor shall clean each conduit by snaking with a steel band to which shall be attached an approved tube cleaner equipped with a mandrel of a diameter not less than 85% of the nominal inside diameter of the conduit. To ensure against corrosion in the areas where hot dipped galvanizing has been damaged, cover all raw metal surfaces with a cold galvanized, zinc rich paint. Install mastic around the flange of the junction box as indicated on the plans before placing concrete.

Stub the conduit out at an accessible location and seal with termination kits designed specifically for that purpose. Use termination kits of the same material as the conduit. Place backfill in accordance with Section 300-7 of the Standard Specifications. Conduit may enter junction boxes through field drilled holes protected with zinc rich paint before the conduit is inserted. Use threaded adapter and insulating bushing at all junction box to conduit connections. Install a pull line in each conduit for future use. Leave sufficient slack for attachment of a rope that will be used to install conductors. Coordinate electrical conduit system work with work by others, and allow installation of light standards, luminaires and circuitry as directed by the Engineer.

Install anchor bolts according to light standard manufacturer's specifications.

All work must be inspected and approved by the Engineer before concealment.

METHOD OF MEASUREMENT

No direct measurement will be made for the conduit system, since it will be paid for on a lump sum basis.

BASIS OF PAYMENT

Lump Sum Basis:

Payment for the conduit system will be made at the contract lump sum price for "Electrical Conduit System at Station _____".

Compensation:



Such price and payment for the conduit system as provided above will be considered full compensation for all materials, equipment, and labor necessary to complete the work in accordance with the plans and these special provisions.

Payment will be made under:

Electrical Conduit System at Station _____ Lump Sum

PROJECT SPECIAL PROVISIONS
UTILITY CONSTRUCTION

Install 200mm DI RJ Water Main, Bridge @ Station 12+21.750 -L-
Install 150mm DI RJ Water Main, Bridge @ Station 11+03.000 -Y1-

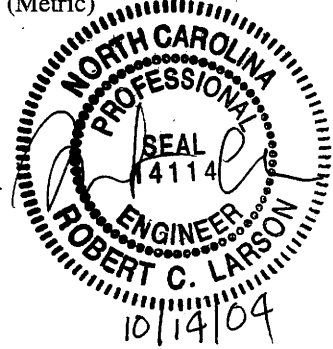

1. **SCOPE OF WORK**

The Contractor shall be responsible for furnishing all equipment and labor, and materials necessary to install a 200mm ductile iron restrained joint water main from station 11+17.949 -L- to station 13+22.855 -L- including attachment of the main to the proposed bridge at station 12+21.750 -L- and a 150mm ductile iron restrained joint water main from station 10+70.145 -Y1- to station 11+35.855 -Y1- including attachment of the main to the proposed bridge at station 11+03.00 -Y1-.

All work shall be performed in accordance with the Structure plans, these Special provisions, the S-N sheet and as directed by the Engineer and subject to the approval of the Owner.

2. **GENERAL CONSTRUCTION REQUIREMENTS**

Material Specifications

When brand names of materials have been determined, the Contractor shall obtain approval from the Engineer and the owner prior to their use and/or installation.

The Contractor shall furnish, but is not limited to furnishing, catalog cuts and/or shop drawings of the materials. Thirty days shall be allowed for the engineer's review of each submittal eight copies of each catalog cut and/or shop drawing (signed and sealed) shall be submitted.

Concrete Inserts

Concrete inserts shall be of an approved galvanized type having a minimum working load tension capacity of 20.0 kN for 22.23mm rods and 10.0 kN for 19.05mm bolts. Concrete Inserts shall be installed in strict compliance with the recommendations specified by the manufacturer.

Hardware

Bolts, nuts, and washers shall be high strength and galvanized in accordance with Article 1072-7 of Standard Specifications.

Hanger Rods

The hanger rods shall be of approved galvanized type, threaded on both ends or threaded continuously and conforming to ASTM-A36 or A-575. The hanger rods shall be of a proper length so as to place the main at the vertical location shown on the plans.

168Pipe Hangers (-Y1-)

The pipe hangers shall be an approved adjustable pipe roller type capable of supporting RJ ductile iron water main and accepting the hanger rod. The entire hanger assembly is to be galvanized except the pipe roll, which is to be coated with a minimum of 6.3 mm thickness of polyvinyl chloride or neoprene.

Lateral Braces (-Y1-)

The lateral braces, including U-bolts, shall be fabricated from ASTM A36 steel and hot dip galvanized in accordance with the details shown on the plans. The U-bolts, with the exception of the threaded ends, shall be coated with a minimum of 6.35 mm thickness of polyvinyl chloride or neoprene.

Only the non-coated ends of the U-bolts are required to be galvanized. The 3.2 mm neoprene or PVC (or equal) pads shall be secured to the end plates and the contact surface between the angle iron and the pipe with epoxy cement or other suitable material.

W-Beam Hanger Assemblies (-L-)

W-beam hanger assemblies, including U-bolts, shall be fabricated from ASTM A36 steel and painted in accordance with the details shown on the plans. The U-bolts, with the exception of the threaded ends, shall be coated with a minimum of 6.35 mm thickness of polyvinyl chloride or neoprene.

Only the non-coated ends of the U-bolts are required to be painted. The 3.2 mm neoprene or PVC (or equal) pads shall be secured to the contact surface between the hanger flange and the pipe with epoxy cement or other suitable material.

Ductile Iron "Restrained Joint" Water Pipe

Ductile Iron Restrained Joint Water Pipe shall be installed in accordance with the applicable utility provisions herein, as shown on the utility plans and/or as directed by the Engineer.

Ductile Iron Restrained Joint Water Pipe shall be of the thickness class and pressure rating shown on the utility plans and shall conform to ANSI A21.51 (AWWA C151). Push-on joints for such pipe shall be in accordance with ANSI A21.11 (AWWA C111). Pipe thickness shall be designed in accordance with ANSI A21.50 (AWWA C150) and based on laying conditions and internal pressures as stated on the plans.

Cement mortar lining and seal coating for pipe shall be in accordance with ANSI A21.4 (AWWA C104). Bituminous outside coating shall be in accordance with ANSI A21.51 (AWWA C151).

All Ductile Iron Restrained Joint Water Pipe shall be installed in accordance with laying condition Type 2 as stated in ANSI A21.51 (AWWA C151) unless otherwise shown on the plans.

Ductile iron restrained joint pipe shall be installed from hangers and insulated to prevent the flow of stray current to bridge.

Ductile iron restrained joint pipe shall be manufactured to the lengths required. Cutting of ductile iron pipe by the contractor will not be allowed.

Provide 2-45 degree bends at termination of water main at station 13+22.855 -L-. See Utility Construction Plans.

Insulation and Aluminum Wrap for Pipe Attached to Bridge

The insulation for the pipe attached to the bridge shall be an approved closed-cell foam type material capable of protecting the main for a minimum of 8.83 hours at -28° C. Any voids created by notching and fitting the insulation at the lateral braces or beam hangers shall be completely filled with spray Urethane Foam or an approved equal. The aluminum wrap shall be of an approved type 0.4mm thick and shall be held firmly in place by aluminum banding tape or by an approved alternate. The insulation shall not be placed around any pipe joint until after the Pressure Test and Leakage Test have been completed. An approved protection saddle shall be provided at each pipe hanger.

Pressure Test, Leakage Test and Sterilization

The pressure test, leakage test and sterilization of the main shall be performed as provided for in the Standard Specifications.

3. PAYMENT

Payment shall be made at the contract lump sum price bid for the items "Install 200mm DI RJ Water Main, Bridge @ Station 12+21.750 -L-" and "Install 150mm DI RJ Water Main, Bridge @ Station 11+03.000 -Y1-," which includes the installation of water main, insulation, fittings, inserts, hangers, lateral braces, labor, materials, and incidentals. The lump sum bid price shall be full compensation for all equipment and labor necessary to complete the work in accordance with the plans, Specifications, and as directed by the Engineer.

THERMAL SPRAYED COATINGS (METALLIZATION)

(2-14-04)

1.0 DESCRIPTION

Apply a thermal sprayed coating (TSC) and sealer to metal surfaces as specified herein when called for on the plans or by other Special Provisions, or when otherwise approved by the Engineer in accordance with the SSPC-CS 23.00/AWS C2.23/NACE No. 12 Specification. Only Arc Sprayed application methods are used to apply TSC coatings, the Engineer must approve other methods of application.

2.0 QUALIFICATIONS

Only use NCDOT approved TSC Contractors meeting the following requirements:

1. Who have the capability of blast cleaning steel surfaces to SSPC SP-5 and SP-10 Finishes.
2. Who employ a Spray Operator(s) qualified in accordance with AWS C.16/C2.16M2002 and a Quality Control Inspector(s) who have documented training in the applicable test procedures of ASTM D-3276 and SSPC-CS 23.00.

A summary of the contractor's related work experience and the documents verifying each Spray Operator's and Quality Control Inspector's qualifications are submitted to the Engineer before any work is performed.

3.0 MATERIALS

Provide wire in accordance with the metallizing equipment manufacturer's recommendations. Use the wire alloy specified on the plans which meets the requirements in Annex C of the SSPC-CS 23.00 Specification. Have the contractor provide a certified analysis (NCDOT Type 2 Certification) for each lot of wire material.

Apply an approved sealer to all metallized surfaces in accordance with Section 9 of SSPC-CS 23. The sealer must either meet SSPC Paint 27 or is an alternate approved by the Engineer.

4.0 SURFACE PREPARATION AND TSC APPLICATION

Grind flame cut edges to remove the carbonized surface prior to blasting. Bevel all flame cut edges in accordance with Article 442-10(D) regardless of included angle. Blast clean surfaces to be metallized with grit or mineral abrasive in accordance with Steel Structures Painting Council SSPC SP-5/10(as specified) to impart an angular surface profile of 2.5 - 4.0 mils (0.063 – 0.100 mm). Surface preparation hold times are in accordance with Section 7.32 of SSPC-CS 23. If flash rusting occurs prior to metallizing, blast clean the metal surface again. Apply the thermal sprayed coating only when the surface temperature of the steel is at least 5°F (3°C) above the dew point.

At the beginning of each work period or shift, conduct bend tests in accordance with Section 6.5 of SSPC-CS 23.00. Any disbonding or delamination of the coating that exposes the substrate requires corrective action, additional testing, and the Engineer's approval before resuming the metallizing process.

Apply TSCs to thickness specified on the plans. All spot results (the average of 3 to 5 readings) must meet the minimum requirement. No additional tolerance (as allowed by SSPC PA-2) is permitted. The specified thickness requirement has been adjusted for surface roughness so that no correction for base metal is needed. (For Steel Beams: For pieces with less than 200 ft² (18.6m²) measure 2 spots/surface per piece and for pieces greater than 200 ft² (18.6m²) add 1 additional spots/surface for each 500 ft² (46.5m²))

When noted on the plans, apply the sealer to all metallized surfaces in accordance with the manufacturer's recommendations. Only apply the seal coat when the air temperature is above 40°F (4°C) and the surface temperature of the steel is at least 5°F (3°C) above the dew point. If the sealer is not applied within eight hours after the final application of TSC, the applicator verifies acceptable TSC surfaces and obtains approval from the Engineer before applying the sealer.

5.0 INSPECTION FREQUENCY

The TSC Contractor must conduct the following tests at the specified frequency and the results documented in a format approved by the Engineer.

TEST/STANDARD	LOCATION	FREQUENCY	SPECIFICATION
Ambient Conditions	Site	Each Process	5°F (3°C) above the dew point
Abrasive Properties	Site	Each Day	Size, angularity, cleanliness
Surface Cleanliness SSPC Vis 1	All Surfaces	Visual All Surfaces	SSPC-SP-10 Atmospheric Service SSPC-SP - 5 Immersion Service
Surface Profile ASTM D-4417 Method C	Random Surfaces	3 per 500 ft ²	2.5 - 4.0 mils
Bend Test SSPC-CS 23.00	Site	5 per shift	Pass Visual
Thickness SSPC PA-2R SSPC-CS 23.00	Each Surface	Use the method in PA-2 Appendix 3 for Girders and Appendix 4 for frames and miscellaneous steel. See Note 1.	Zn - 8.0 mils minimum Al - 12 mils minimum Areas with more than twice the minimum thickness are inspected for compliance to the adhesion and cut testing requirements of this specification.
Adhesion ASTM 4541	Random Surfaces Splice Areas	1 set of 3 per 500 ft ²	ZN > 500 psi Al > 1000 psi
Cut Test - SSPC-CS 23.00	Random Surfaces	3 sets of 3 per 500 ft ²	No peeling or delamination
Job Reference Std. SSPC-CS 23.00	Site	1 per job	Meets all the above requirements

6.0 REPAIRS

All Repairs are to be performed in accordance with the procedures below, depending on whether the repair surface is hidden or exposed. As an exception to the following, field welded splices on joint angles may be repaired in accordance with the procedures for hidden surfaces.

For hidden surfaces (including but not limited to interior girders, interior faces of exterior girders, and below-grade sections of piles):

1. Welding of metallized surfaces may be performed only if specifically permitted by the Engineer. Remove metallizing at the location of field welds by blast cleaning (SSPC SP-6 finish), or hand (SSPC SP-2 finish) or power tool cleaning (SSPC SP-3 finish) just prior to welding. Clean sufficiently to prevent contamination of the weld. All repairs to welded connections are metallized in accordance with SSPC CS 23.00.
2. Minor areas less than or equal to 0.1 ft^2 (9300mm^2) exposing the substrate are metallized in accordance with SSPC CS 23.00 or painted in accordance with ASTM A780, "Repair of Damaged and Uncoated Areas of Hot Dip Galvanized Coatings."
3. Large areas greater than 0.1 ft^2 (9300mm^2) exposing the substrate are metallized in accordance with SSPC CS 23.00.
4. Damaged (burnished) areas not exposing the substrate with less than the specified coating thickness are metallized in accordance with SSPC CS 23.00 or painted in accordance with ASTM A780, "Repair of Damaged and Uncoated Areas of Hot Dip Galvanized Coatings."
5. Damaged (burnished) areas not exposing the substrate with more than the specified coating thickness are not repaired.
6. Defective coating is repaired by either method 2 or 3 depending on the area of the defect.

For Exposed Surfaces (including but not limited to exterior faces of exterior girders and above-grade sections of piles):

1. Welding of metallized surfaces may be performed only if specifically permitted by the Engineer. Remove metallization at the location of field welds by blast cleaning (SSPC SP-6 finish), or hand (SSPC SP-2 finish) or power tool cleaning (SSPC SP-3 finish) just prior to welding. Clean sufficiently to prevent contamination of the weld. All repairs to welded connections are metallized in accordance with SSPC CS 23.00.
2. All areas exposing the substrate are metallized in accordance with SSPC CS 23.00
3. Defective coating is repaired by either method 2 or 3 depending on the area of the defect.

7.0 TWELVE MONTH OBSERVATION PERIOD

The contractor maintains responsibility for the coating system for a twelve (12) month observation period beginning upon the satisfactory completion of all the work required in the plans or as directed by the engineer. The contractor must guarantee the coating system under the payment and performance bond (refer to article 109-10). To successfully complete the observation period, the coating system must meet the following requirements after twelve(12) months service:

- No visible rust, contamination or application defect is observed in any coated area.
- Painted surfaces have a uniform color and gloss.
- Surfaces have an adhesion of no less than 500 psi (3.45 MPa) when tested in accordance with ASTM D-4541.

8.0 BASIS OF PAYMENT

The contract price bid for the bridge component to which the coating is applied will be full compensation for the thermal sprayed coating.