

NOTES

FOR PILASTER REINFORCING STEEL AND DETAILS @ END OF APPROACH SLAB, SHEET 9 OF 14.

THE CONCRETE AND REINFORCING STEEL FOR THE CLASSIC CONCRETE BRIDGE RAIL AND SIDEWALK ON THE APPROACH SLAB ARE INCLUDED IN THE BILL OF MATERIAL FOR THE APPROACH SLAB AND SHALL BE INCLUDED IN THE LUMP SUM COST FOR "BRIDGE APPROACH SLABS".

FOR CLASSIC CONCRETE BRIDGE RAIL AND SIDEWALK SECTIONS, SEE SHEET 10 OF 14.

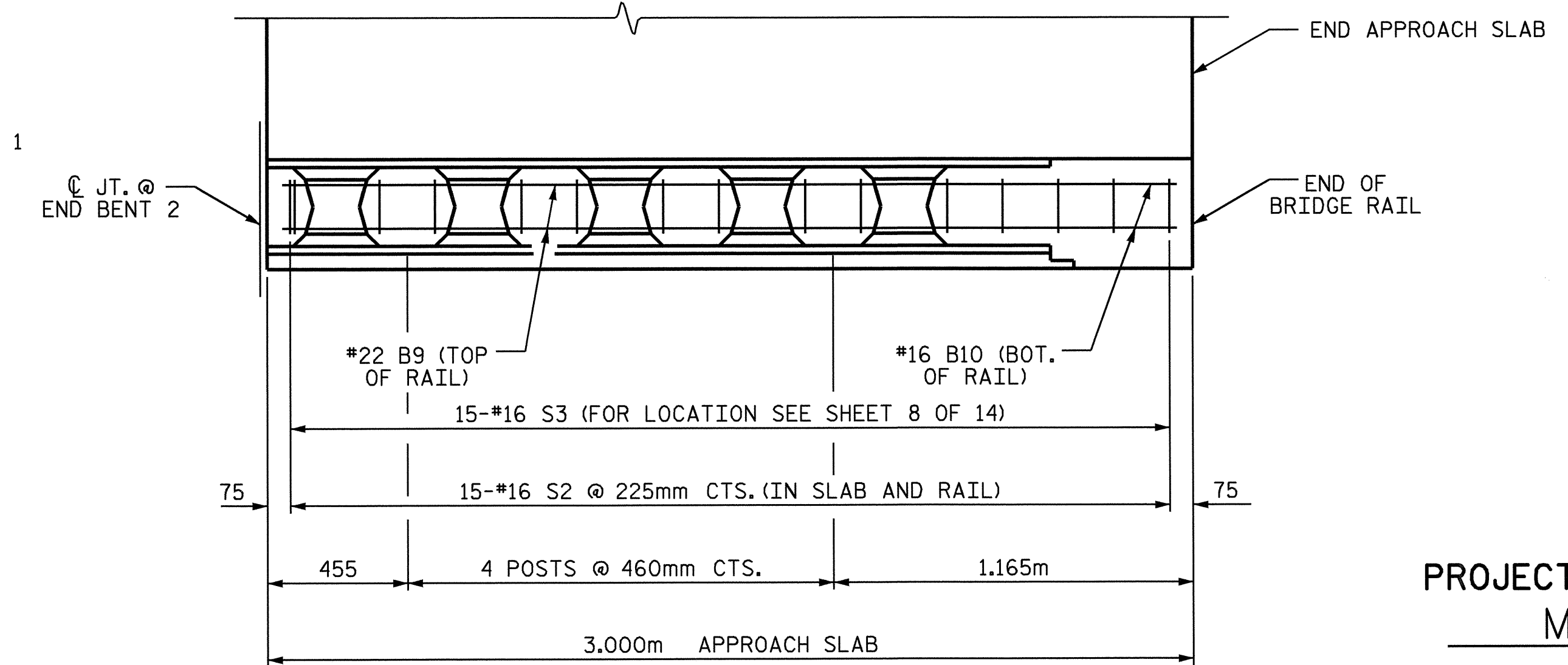
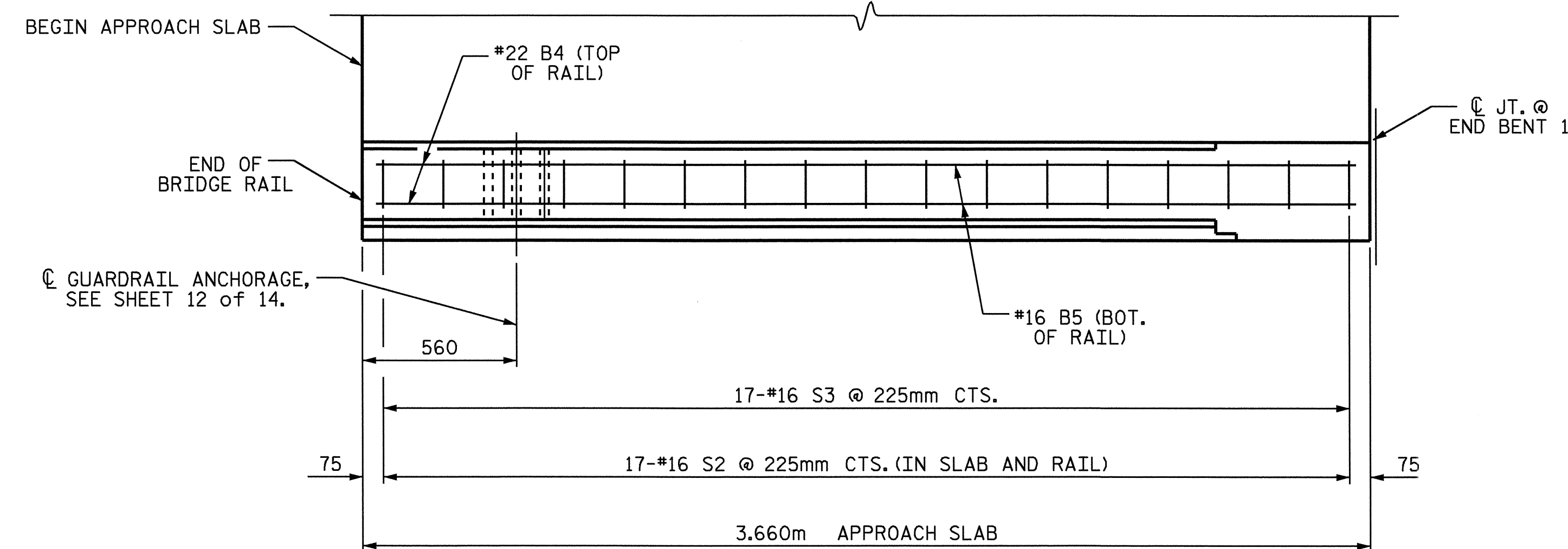
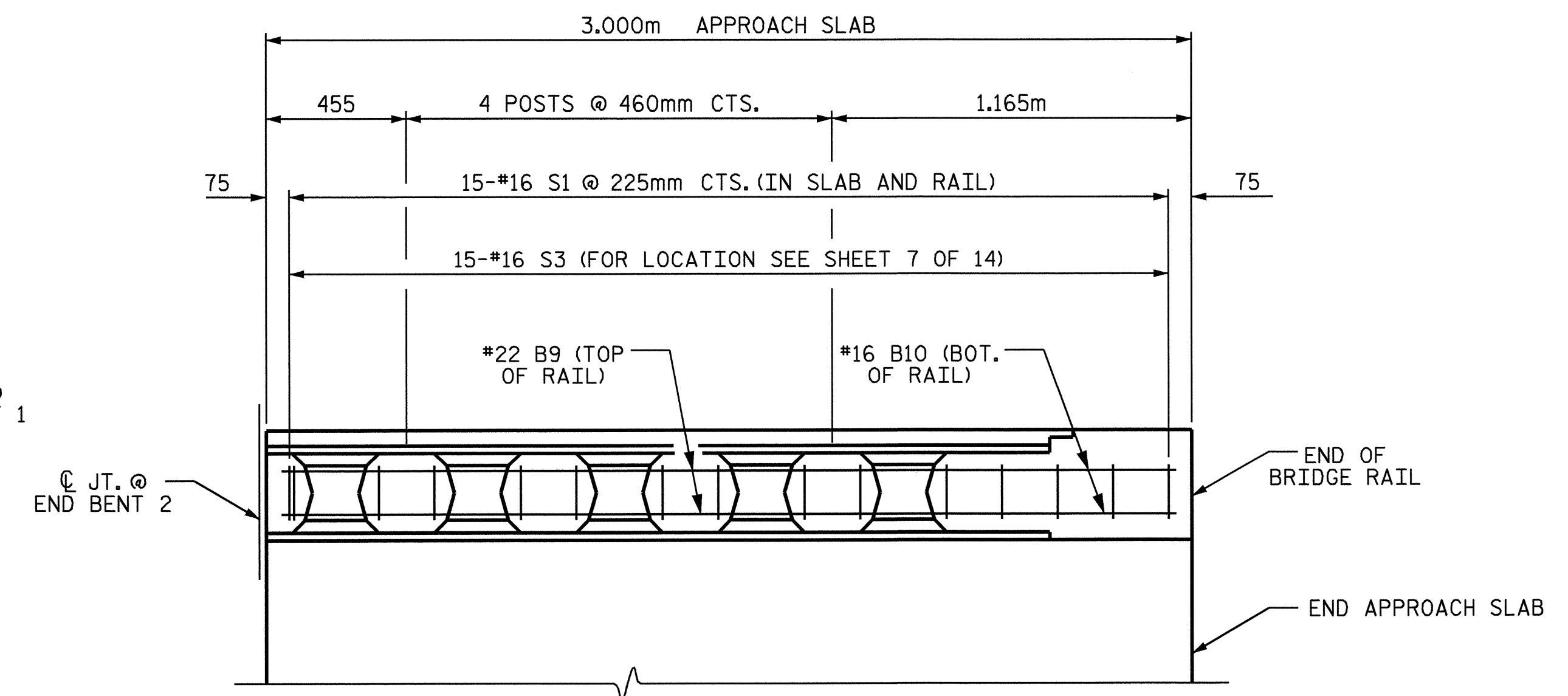
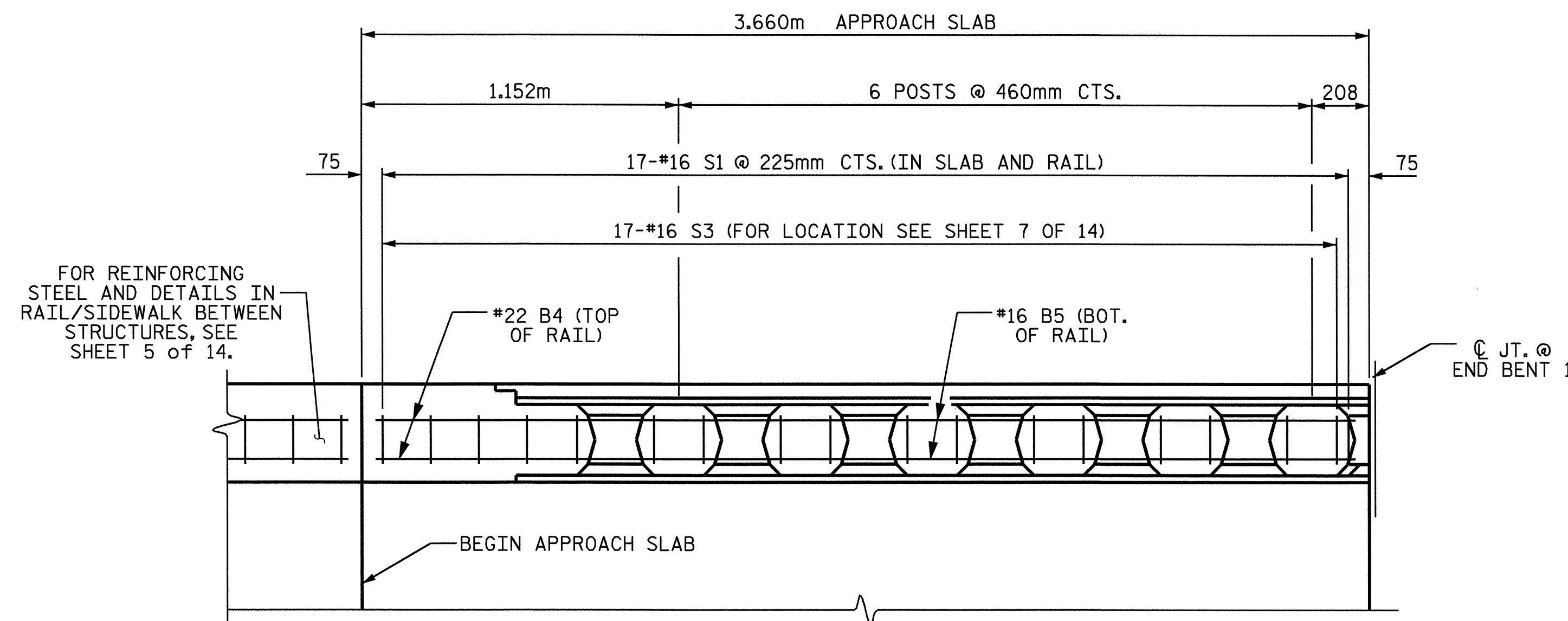

END BENT 1

END BENT 2

PLAN OF CLASSIC RAIL @ APPROACH SLABS

PROJECT NO. B-2583
MADISON COUNTY
 STATION: 12+21.750 -L-

SHEET 4 of 14

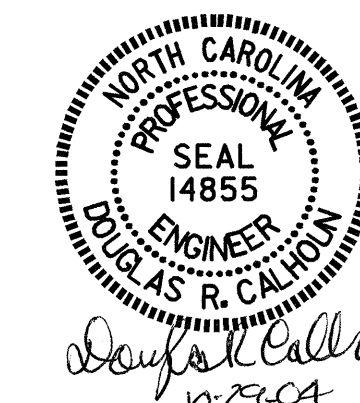

| | | | | | |
|------------------------------|-----|-------|-----|-----|--------------|
| STATE OF NORTH CAROLINA | | | | | |
| DEPARTMENT OF TRANSPORTATION | | | | | |
| RALEIGH | | | | | |
| CLASSIC CONCRETE | | | | | |
| BRIDGE RAIL | | | | | |
| FOR BRIDGE | | | | | |
| APPROACH SLAB | | | | | |
| REVISIONS | | | | | SHEET NO. |
| NO. | BY: | DATE: | NO. | BY: | S-58 |
| 1 | | | 3 | | TOTAL SHEETS |
| 2 | | | 4 | | 112 |

DRAWN BY : T. A. HARRIS DATE : 8/24/04
 CHECKED BY : K. P. SEDAI DATE : 9/14/04

29-OCT-2004 09:46
 W:\squado\b2583\taharris\Microstation\str\b2583.sd.as.01.dgn
 TAHarris