

10-SEP-2003 09:46 c:\p03\c030005\standard\dwg\sig\11\sheet174201.plt on sheet.dgn

STATE OF NORTH CAROLINA DEPT. OF TRANSPORTATION DIVISION OF HIGHWAYS RALEIGH, N.C.

ENGLISH STANDARD DRAWING FOR METAL POLE FOUNDATIONS REINFORCING CAGE DETAILS

SHEET 1 OF 2 1742.01

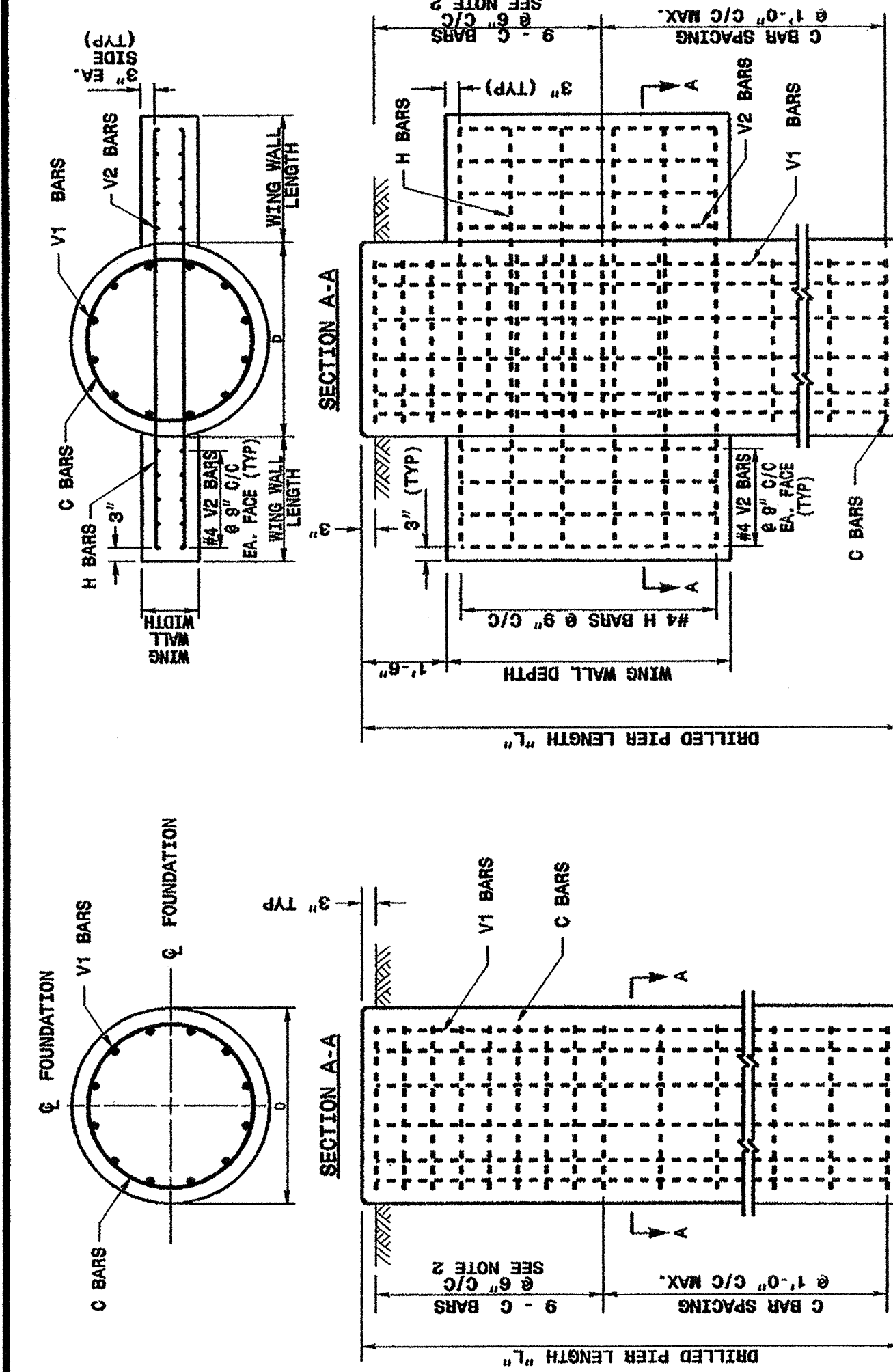

REINFORCING STEEL TABLE FOR STANDARD DRILL PIER SHAFT (42" & 48" DIAMETER)

SHAFT DIA. (in.)	BAR VOLUME (cu. yds.)	No.	Size	Type	Length
42"	.868 X L	V1	#8	STR.	**
		D	#4	STR.	10'-9"
48"	.465 X L	V1	#8	STR.	**
		D	#4	STR.	12'-6"

** See Construction Note No. 1.
*** See Construction Note No. 2.

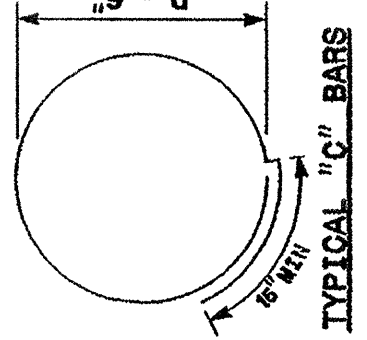

REINFORCING STEEL TABLE FOR STANDARD 42" and 48" DRILL PIER SHAFT WITH TYPE 1 AND TYPE 2 WING WALLS

Wing Wall Type	Drill Pier Shaft Dia. (in.)	Bar No.	Size	Type	Length
TYPE 1	42"	V1	#8	STR.	**
		V2	#4	STR.	2'-6"
		H	#4	STR.	9'-0"
		C	#4	STR.	10'-9"
TYPE 2	42"	V1	#8	STR.	**
		V2	#4	STR.	2'-6"
		H	#4	STR.	9'-0"
		C	#4	STR.	10'-9"
TYPE 2	48"	V1	#8	STR.	**
		V2	#4	STR.	2'-6"
		H	#4	STR.	9'-0"
		C	#4	STR.	12'-6"

** See Construction Note No. 1.
*** See Construction Note No. 2.

WING WALL DETAILS

Wing Wall Type	Wing Wall Width (ft.)	Wing Wall Depth (ft.)	Concrete Volume (Cu. Yds.)
TYPE 1	1'-6"	1'-0"	3'-0"
TYPE 2	3'-0"	1'-0"	6'-0"
			1'-2"

** See Construction Note No. 1.
*** See Construction Note No. 2.

STATE OF NORTH CAROLINA DEPT. OF TRANSPORTATION DIVISION OF HIGHWAYS RALEIGH, N.C.

ENGLISH STANDARD DRAWING FOR METAL POLE FOUNDATIONS REINFORCING CAGE DETAILS

SHEET 1 OF 2 1742.01

- NOTES
1. THE NUMBER OF C-BARS IS BASED ON FOUNDATION DEPTH. SEE FOUNDATION SELECTION TABLES.
 2. CIRCULAR TIE REINFORCING RINGS MAY BE VERTICALLY ADJUSTED BY +/- 3" AT A DEPTH BETWEEN 2'-0" AND 3'-0" TO FACILITATE THE INSTALLATION OF ELECTRICAL CONDUIT ENTERING IN THE CAGE.
 3. THE LENGTH OF V1-BARS IS BASED ON FOUNDATION DEPTH. SEE FOUNDATION SELECTION TABLES.
 4. THE QUANTITIES FOR STEEL AND CONCRETE SHOWN IN THE WING WALL DETAILS CHART REFLECTS THE AMOUNT OF MATERIAL FOR PAIR OF WING WALLS (2 WING WALLS PER DRILL PIER SHAFT).
 5. CONCRETE DRILL PIER SHAFT VOLUME (CU. YDS.):
FOR 42" DIA. = .868X L
FOR 48" DIA. = .465X L
 6. DEFORM REINFORCING STEEL TO CONFORM TO ASTM A615 GRADE 60. TIES MAY BE DEFORMED OR PLAIN.
 7. CAST CONCRETE AGAINST UNDISTURBED SOIL.
 8. DO NOT ERECT TRAFFIC SIGNAL STRUCTURES BEFORE THE CONCRETE IN THE FOUNDATION HAS ATTAINED A MINIMUM COMPRESSIVE STRENGTH OF 3000 PSI.
 9. MAKE PROVISIONS FOR DRAINAGE OF WATER FROM INSIDE OF THE METAL SUPPORT.
 10. FOR OTHER DETAILS REGARDING CONSTRUCTION OF CONCRETE FOUNDATION SEE PROJECT SPECIAL PROVISIONS.
 11. IN CASE OF ANY CROSS SLOPES, GRADE AROUND THE FOUNDATION AS FOLLOWS:

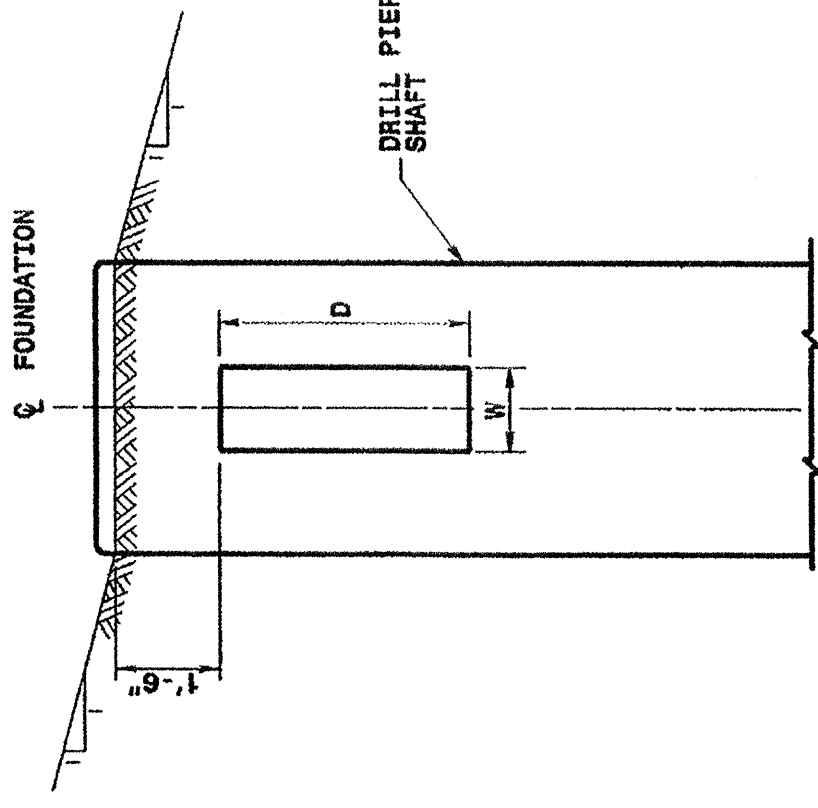

STATE OF NORTH CAROLINA DEPT. OF TRANSPORTATION DIVISION OF HIGHWAYS RALEIGH, N.C.

ENGLISH STANDARD DRAWING FOR METAL POLE FOUNDATIONS INSTALLATION DETAILS

SHEET 2 OF 2 1742.01

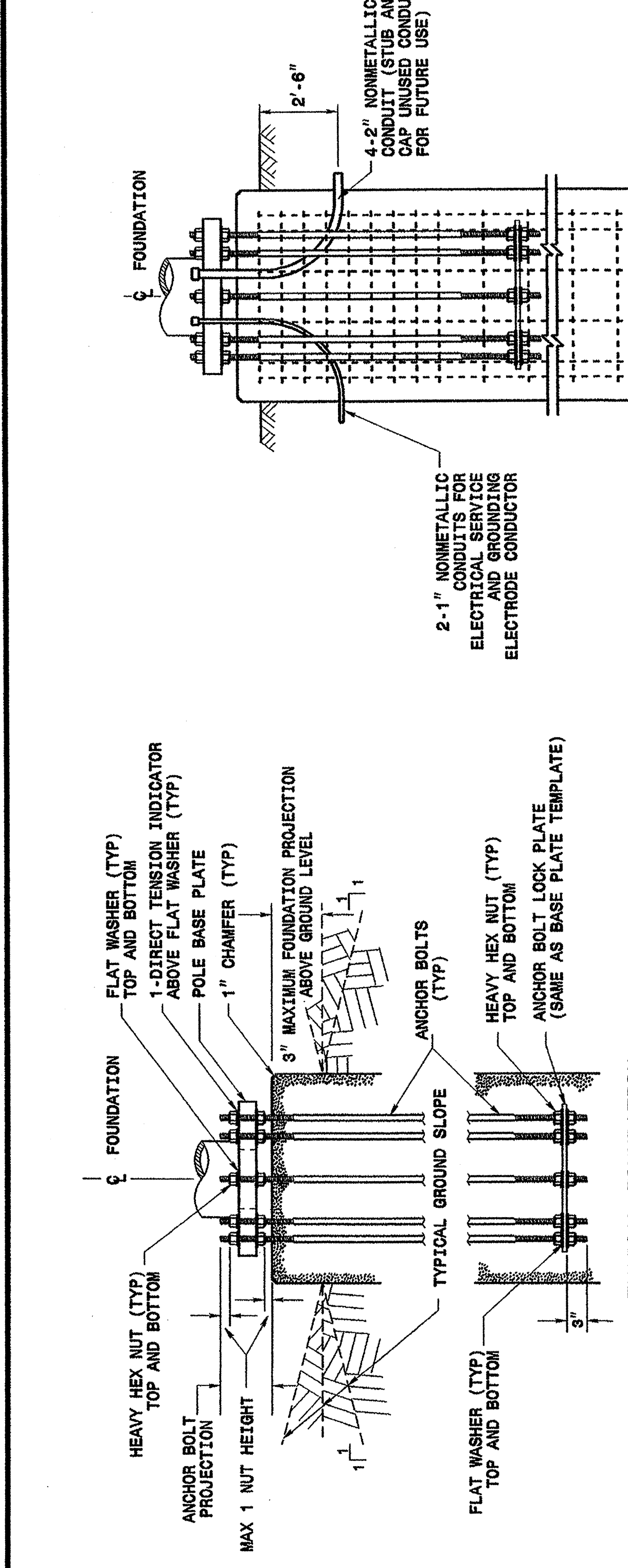

TYPICAL FOUNDATION ANCHOR BOLT DETAILS REINFORCING CAGE NOT SHOWN FOR CLARITY

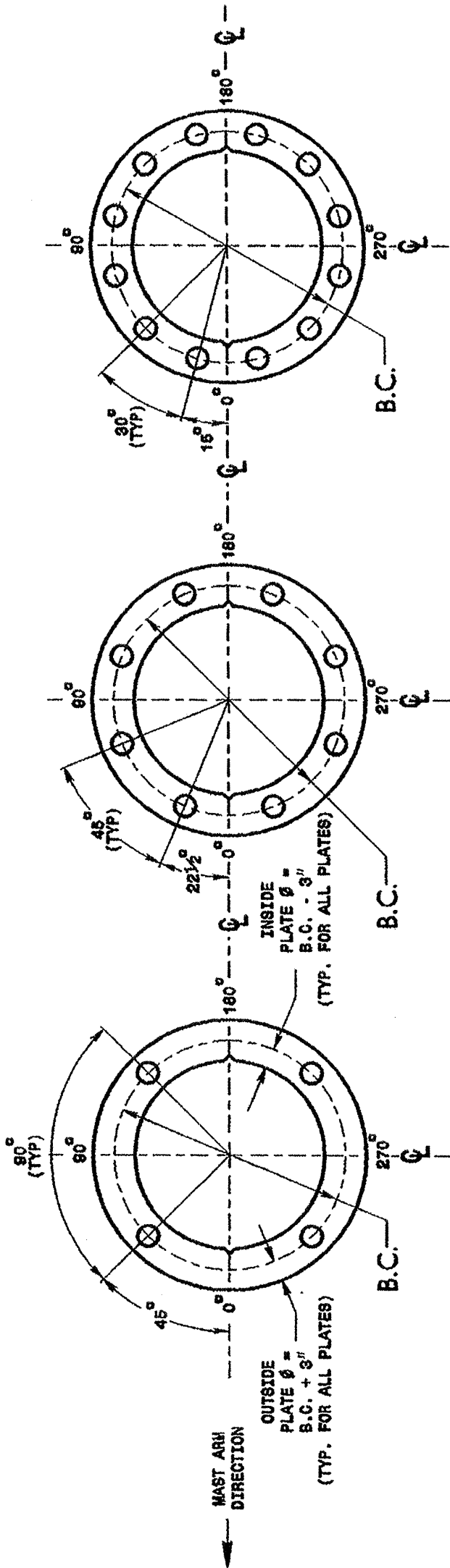

FOR 4 BOLT BASE PLATE
FOR 8 BOLT BASE PLATE
FOR 12 BOLT BASE PLATE
CONSTRUCT TEMPLATES AND PLATES FROM 9/8" THICK STEEL. GALVANIZING IS NOT REQUIRED.
BASE PLATE TEMPLATE AND ANCHOR BOLT LOCK PLATE DETAILS

STATE OF NORTH CAROLINA DEPT. OF TRANSPORTATION DIVISION OF HIGHWAYS RALEIGH, N.C.

ENGLISH STANDARD DRAWING FOR METAL POLE FOUNDATIONS INSTALLATION DETAILS

SHEET 2 OF 2 1742.01

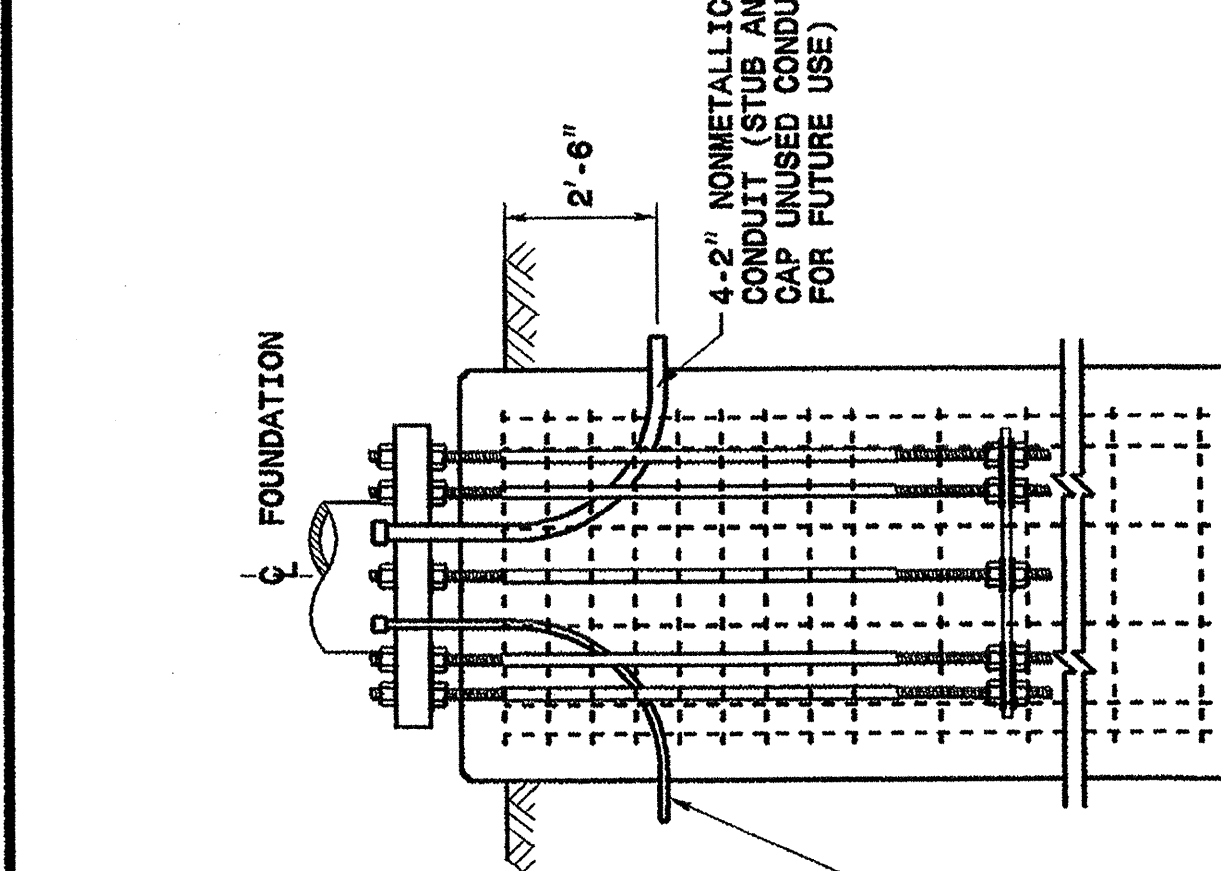

TYPICAL FOUNDATION CONDUIT DETAILS

<p>Structural Engineer</p> <p>Signature: <i>D. Sarthar</i> DATE: 9.12.03</p>	<p>Electrical Engineer</p> <p>Signature: <i>Milton J. Dean</i> DATE: 9/18/03</p>
<p>Standard Drawings</p> <p>Traffic Management and Signal Systems Unit 122 N. McDowell St., Raleigh, NC 27603</p>	
<p>See Plate for Title</p>	
<p>Original: 2002 Standards</p>	