

STATE OF NORTH CAROLINA  
DEPT. OF TRANSPORTATION  
DIVISION OF HIGHWAYS  
RALEIGH, N.C.

ENGLISH DETAIL DRAWING FOR  
**TEMPORARY 47" WOVEN WIRE FENCE**  
WITH WOOD POST

SHEET 1 OF 1  
**866D02**

NOTE: SEE STANDARD DRAWING 862.02 FOR CONSTRUCTION OF FENCE  
(WOOD POST HAVE BEEN SHORTENED 6" AND BARBED WIRE HAS BEEN DELETED)

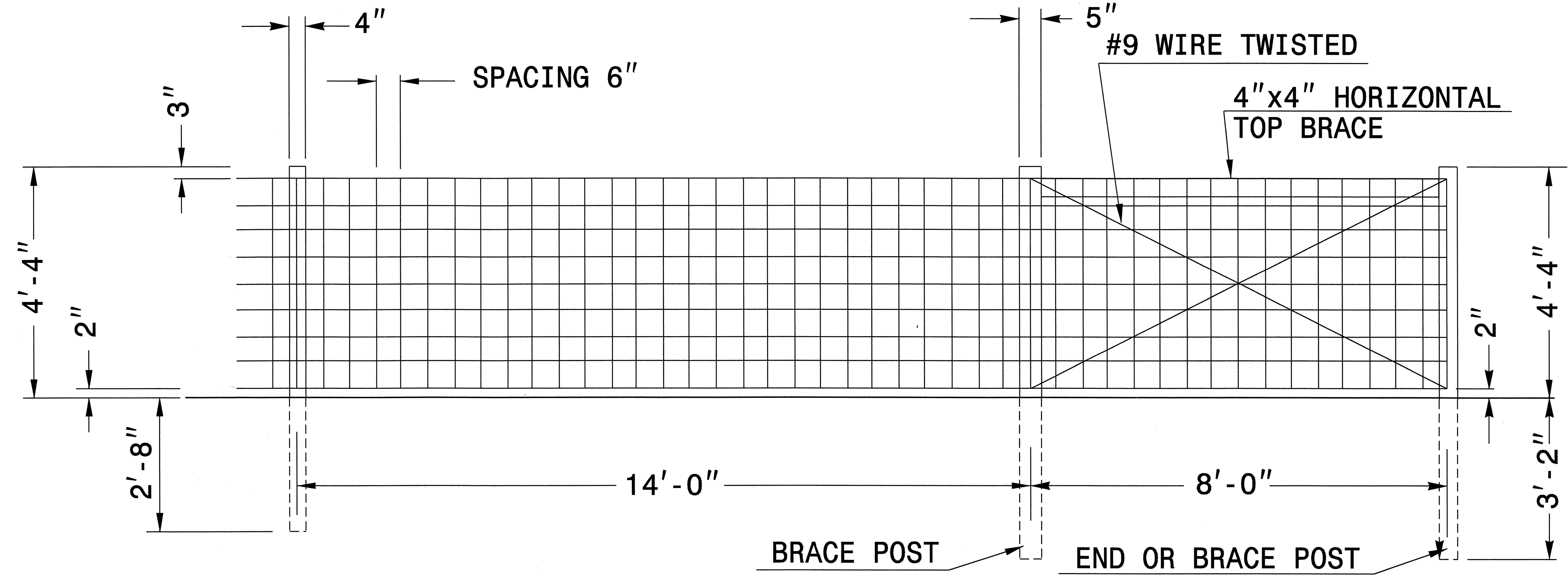

**TEMPORARY 47" WOVEN WIRE FENCE**

STATE OF NORTH CAROLINA  
DEPT. OF TRANSPORTATION  
DIVISION OF HIGHWAYS  
RALEIGH, N.C.

ENGLISH DETAIL DRAWING FOR  
**TEMPORARY 47" WOVEN WIRE FENCE**  
WITH WOOD POST

SHEET 1 OF 1  
**866D02**

29-OCT-2003 14:18  
W:\Special\Detail\std\std\std\std\Fence\866d02.dgn  
erfordard 11/05/2003

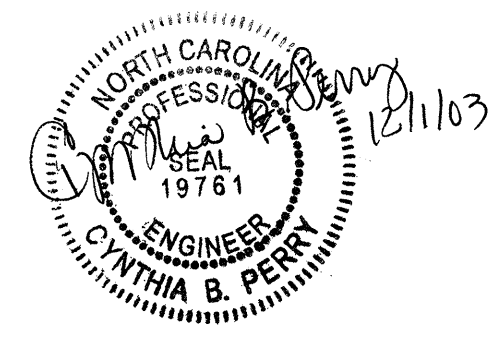

DESIGN SERVICES UNIT  
STANDARDS AND SPECIAL DESIGN  
Office 919-250-4128 FAX 919-250-4119

**SEE PLATE FOR TITLE**

ORIGINAL BY: E.E. WARD DATE: 10-29-03  
MODIFIED BY: DATE:  
CHECKED BY: DATE: 10-03  
FILE SPEC.: W:\Special\Detail\std\std\std\std\Fence\866d02.dgn