

8/17/99

PROJECT REFERENCE NO.	SHEET NO.
1-2102	EC-13/CONST.8
RW SHEET NO.	8
ROADWAY DESIGN ENGINEER	HYDRAULICS ENGINEER

SCOTT H. FLEMING
AND WIFE
GAYLE A. FLEMING
DB 214 PG 3886
PB 24 PG 30

HOWARD CARVIU
AND WIFE
CYNTHIA J. CARVIU
DB 198 PG 854
PB 24 PG 30

JAMES WALTER ETCHISON
AND WIFE
DAHLGREN C. ETCHISON
DB 1229 PG 196
PB 24 PG 30

ROBERT B. SUTTON JR.
AND WIFE
VICKIE S. SUTTON
DB 1362 PG 235
PB 24 PG 30

J. STERLING WHITE
AND WIFE
LUCIE M. WHITE
DB 1827 PG 855
PB 25 PG 74

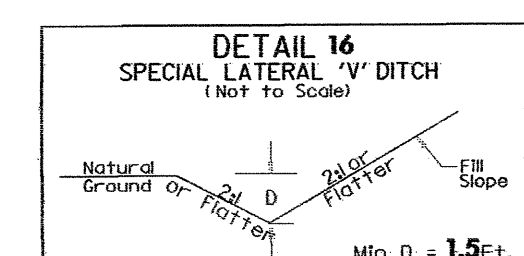
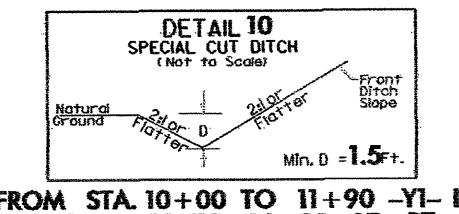
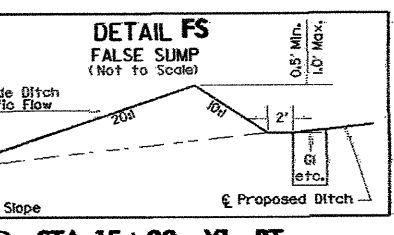

RAMP "C"
PIs Sta 4+08.46
Δs = 1' 25' 56.6"
Ls = 200.00'
LT = 133.34'
ST = 66.67'

-Y3-
PI Sta 11+53.31
Δs = 3' 51' 03.9" (RT)
D = 38' 11' 49.9"
L = 91.24'
T = 47.08'
R = 150.00'

RAMP "C"
PI Sta 5+85.60
Δs = 3' 09' 51.5" (RT)
D = 1' 25' 56.6"
L = 220.91'
T = 110.48'
R = 4,000.00'

RAMP "C"
PIs Sta 7+62.70
Δs = 1' 25' 56.6"
Ls = 200.00'
LT = 133.34'
ST = 66.67'

RAMP "B"
PIs Sta 1+33.35
Δs = 2' 32' 47.3"
Ls = 200.00'
LT = 133.35'
ST = 66.68'

RAMP "B"
PIs Sta 4+93.30
Δs = 14' 51' 13.4" (LT)
D = 2' 32' 47.3"
L = 583.30'
T = 293.30'
R = 2,250.00'

-Y2-
PI Sta 10+97.83
Δs = 25' 33' 11.3" (LT)
D = 38' 11' 49.9"
L = 66.90'
T = 34.01'
R = 150.00'

CURTIS R. LITTLE
AND WIFE
LYNNE M. LITTLE
DB 1998 PG 2784
PB 25 PG 74

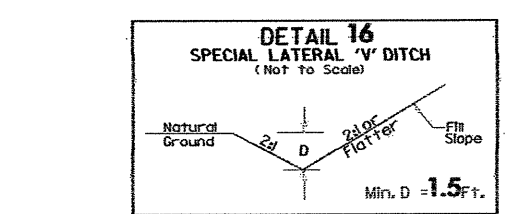

FROM STA. 4+35 TO 7+50 RMP-B-LT
STA. 5+40 TO 8+00 RMP-B-RT

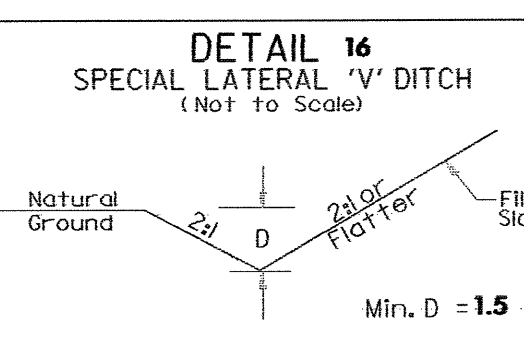

FROM STA. 25+50 TO 28+20 -Y1- LT
STA. 25+12 TO 27+00 -Y1- RT

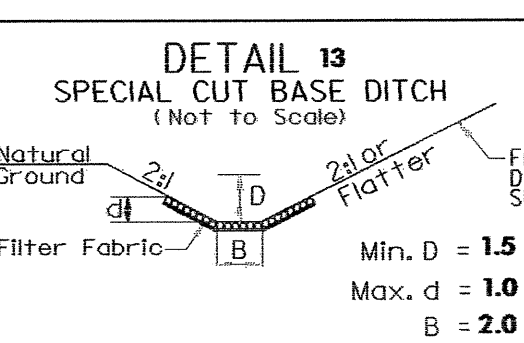

FROM STA. 24+40 TO 25+50 -Y1- LT
EST 40 TONS
EST 61 S.Y. F.F.

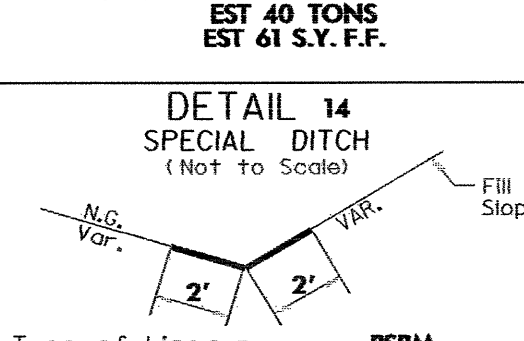

FROM STA. 2+00 TO 3+00 RMP-A-RT
STA. 1+00 TO 2+50 RMP-A-LT
EST. 125 S.Y. PSRM

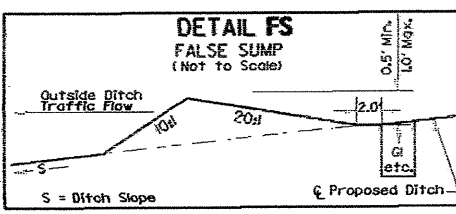

STA. 17+25 -140EP- LT
STA. 21+25 -140EP- LT

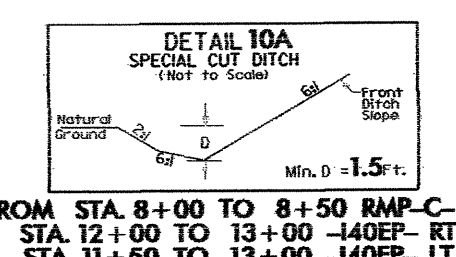

FROM STA. 8+00 TO 8+50 RMP-C-RT
STA. 12+00 TO 13+00 -140EP- RT
STA. 11+50 TO 13+00 -140EP- LT

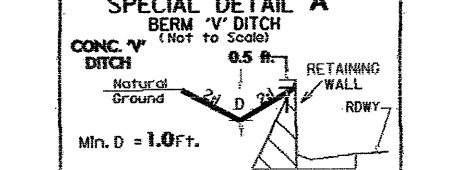

FROM STA. 1+50 TO 5+65 RMP-C-RT
SEE STD. #850.01
CONCRETE PAVED DITCH

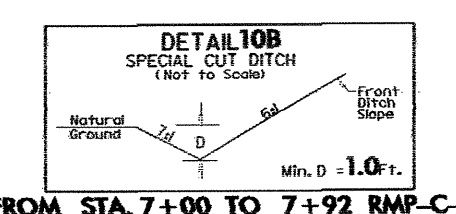

FROM STA. 7+00 TO 7+92 RMP-C-LT

14-Jul-2004 17:31
C:\Users\james\Documents\1-2102\ps6REV.psh
james