

UTILITIES BY OTHERS

NOTE:
ALL PROPOSED UTILITY WORK
SHOWN ON THIS SHEET WILL
BE DONE BY OTHERS

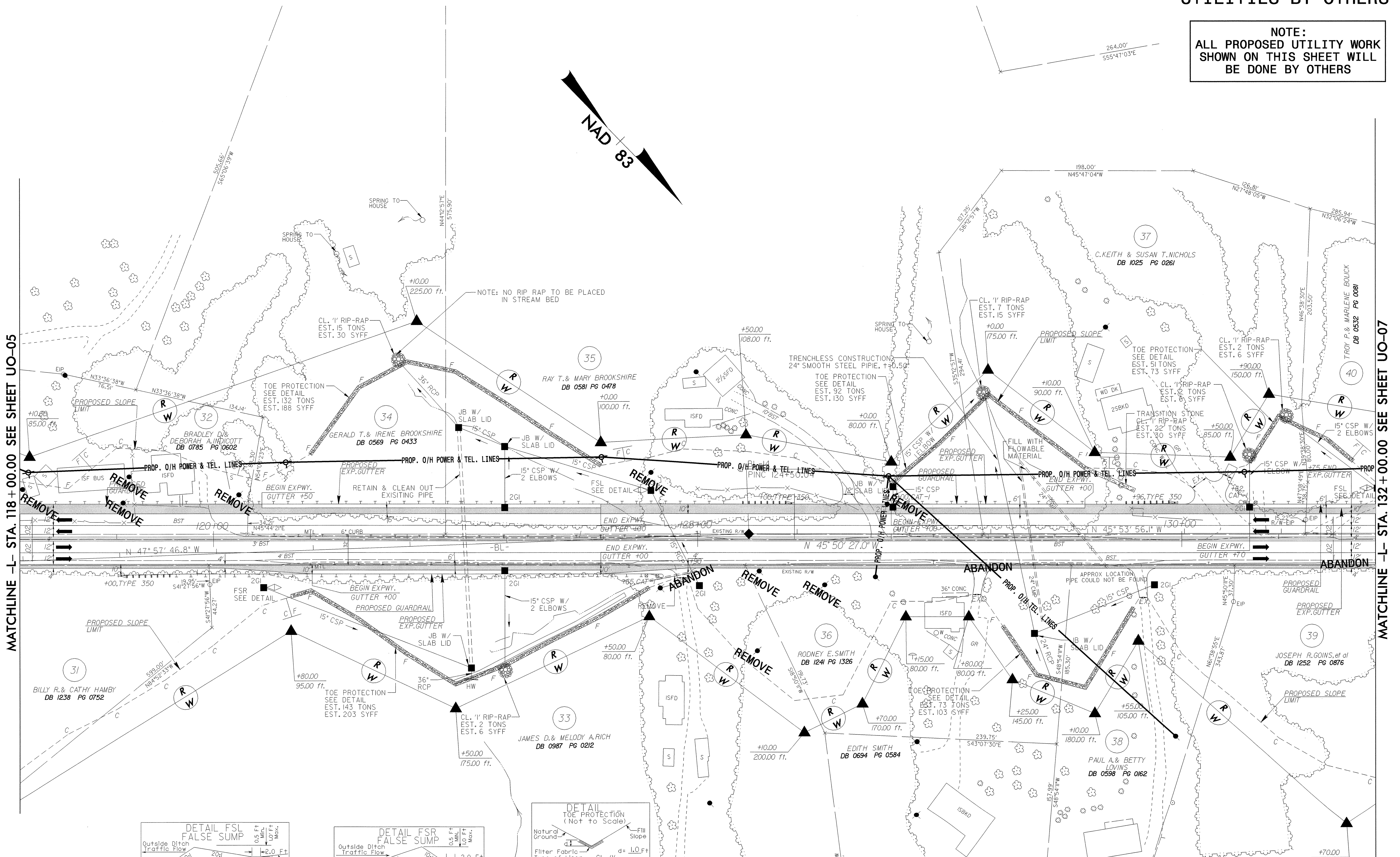
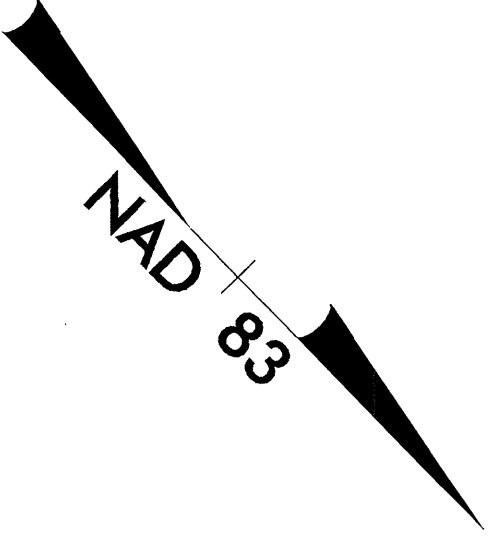

MATCHLINE -L- STA. 118+00.00 SEE SHEET UO-05

MATCHLINE -L- STA. 132+00.00 SEE SHEET UO-07

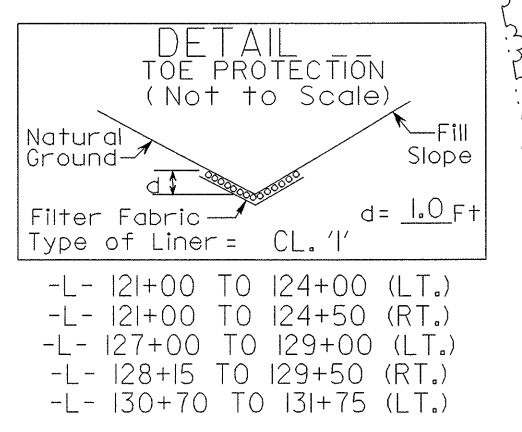
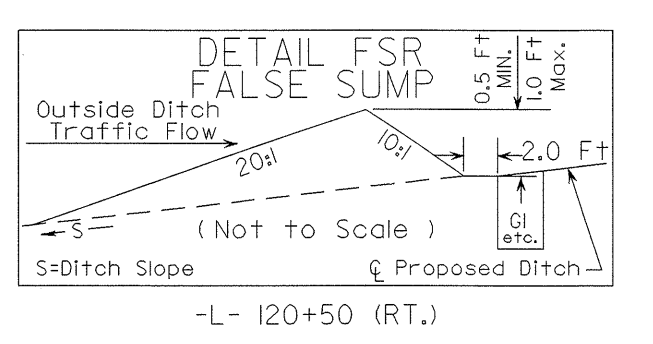
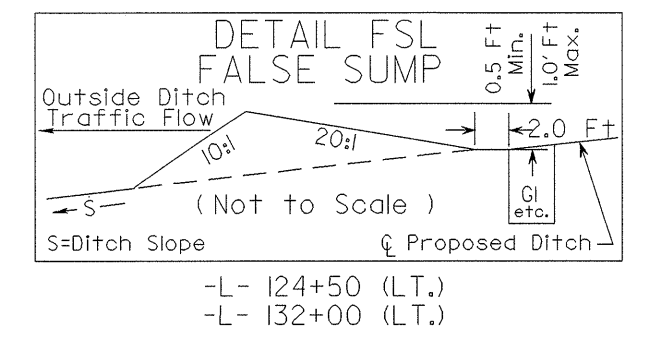

- NOTES:
1. DRIVEWAY RETURN RADII ARE 10' UNLESS OTHERWISE SHOWN
 2. ALL CSP WILL BE ROD LUG AND GASKET CONNECTOR
 3. ALL U/G TELEPHONE LOCATED AS MARKED BY PRO-MARK ON JULY 17 AND 18, 2000

REFERENCES:
FOR -L- PROFILE SEE SHEET 41

8/17/99
CL:\SEP-2004\15-40\14\X\Fc\N\R-2237b_ut_UO_06psh_13.dgn
CL:\SEP-2004\15-40\14\X\Fc\N\R-2237b_ut_UO_06psh_13.dgn
CL:\SEP-2004\15-40\14\X\Fc\N\R-2237b_ut_UO_06psh_13.dgn