

EXTERIOR GIRDER

INTERIOR GIRDER

DETAIL OF REQUIRED OVERHANG FALSEWORK BRACING SYSTEM

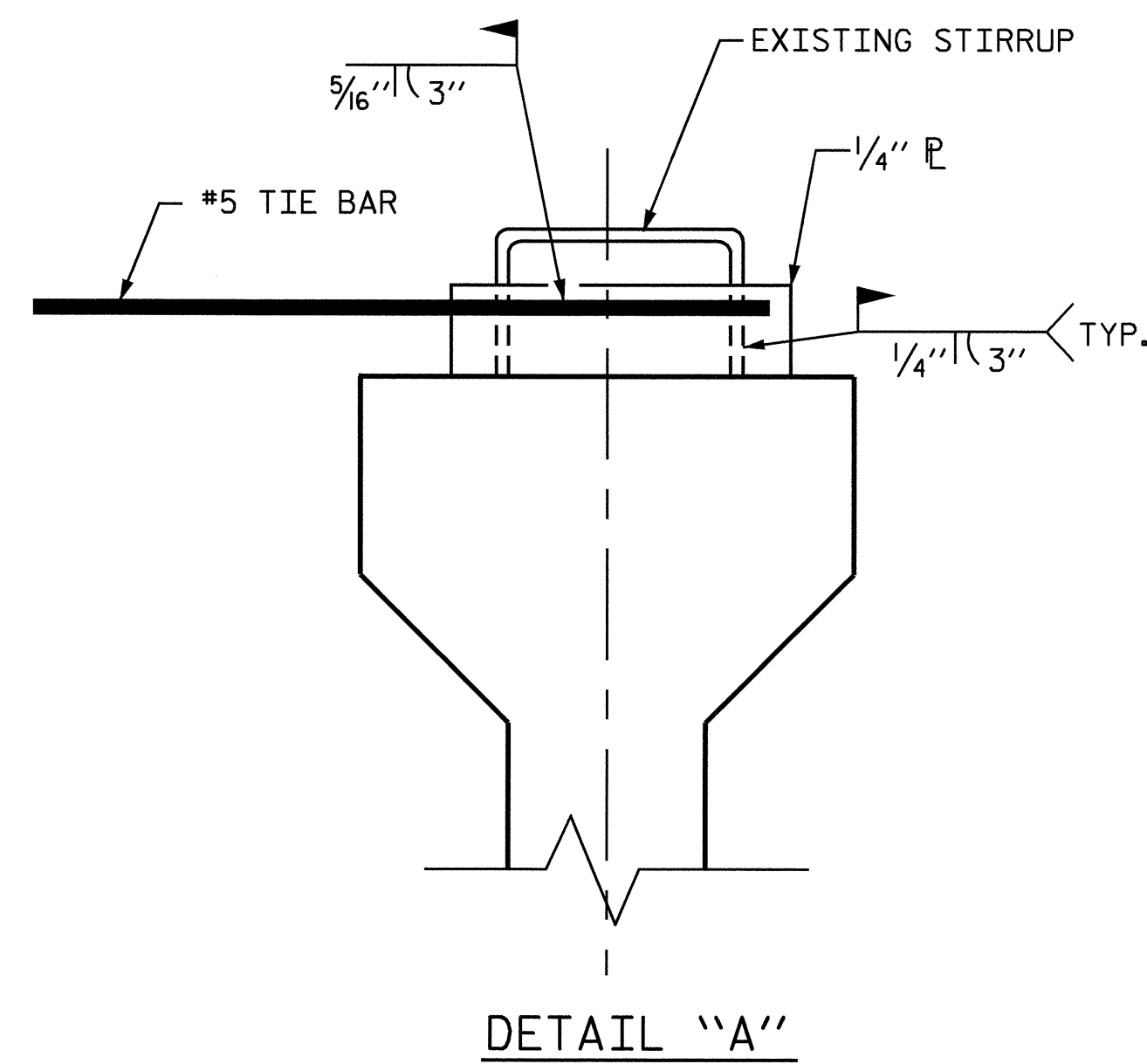

DETAIL "A"

NOTES:

EACH #5 TIE BAR SHALL BE WELDED TO ONE STIRRUP LOOP AS SHOWN IN DETAIL "A". #5 TIE BARS SHALL BE WELDED TO TWO ADJACENT STIRRUPS OF THE EXTERIOR GIRDER AND THE ADJACENT INTERIOR GIRDER BETWEEN PERMANENT DIAPHRAGMS. WELD STEEL PLATES IN BETWEEN THE TIE BARS AND THE STIRRUP LOOP. WELDING TWO TIE BARS TO THE SAME STIRRUP LOOP SHALL NOT BE PERMITTED.

MAXIMUM SPACING BETWEEN THE BRACING (TIE BARS-TIMBER STRUT) IS 8'-6" CTS. #5 TIE BARS SHALL BE LOCATED OVER A TIMBER STRUT.

INSTALL TIE BARS AND TIMBER STRUTS PRIOR TO PLACEMENT OF CONCRETE OR SCREED WEIGHT ONTO THE OVERHANG FALSEWORK.

PROJECT NO. R-2562C
BLADEN COUNTY
 STATION: 178+79.500 -L- REV.

SHEET 3 OF 3

STATE OF NORTH CAROLINA
 DEPARTMENT OF TRANSPORTATION
 RALEIGH
 STANDARD OVERHANG FALSEWORK
 AASHTO TYPES
 III, IV, V, AND VI
 (LEFT LANE)



Chang-Chuan V. Chao
 10-18-2004

DRAWN BY: R. WRIGHT 06/04 DATE : _____
 CHECKED BY: V. CHAO 06/04 DATE : _____

18-OCT-2004 14:54
 W:\sqadd\B08\FOR VICTOR\R2562C_OverHangSheets.dgn
 rwwright

REVISIONS						SHEET NO.
NO.	BY:	DATE:	NO.	BY:	DATE:	5-34
1			3			TOTAL SHEETS
2			4			68