

**NOTES**

- STIRRUPS IN CAP MAY BE SHIFTED AS NECESSARY TO CLEAR ANCHOR BOLTS.
- FOR EPOXY PROTECTIVE COATING, SEE SPECIAL PROVISIONS.
- PIPE DRAINS MAY BE SHIFTED SLIGHTLY AS NECESSARY TO CLEAR REINFORCING STEEL AND ANCHOR BOLTS.
- BACKWALL SHALL BE PLACED BEFORE APPLYING THE EPOXY PROTECTIVE COATING.
- THE TOP SURFACE AREAS OF THE END BENT CAPS SHALL BE CURED IN ACCORDANCE WITH THE STANDARD SPECIFICATIONS EXCEPT THAT THE MEMBRANE CURING COMPOUND METHOD SHALL NOT BE USED.
- THE TOP SURFACE OF THE CAP EXCEPT THE BRIDGE SEAT BUILDUPS SHALL BE SLOPED TRANSVERSELY FROM THE FILL FACE TO THE BACK FACE AT THE RATE OF 2%.
- THE CONTRACTOR MAY PROPOSE AN ALTERNATE METHOD FOR PLUGGING THE STEEL PIPE PILE, SUBJECT TO APPROVAL BY ENGINEER.
- THE CONTRACTOR SHALL PROVIDE FOR INSTALLATION OF THE 4" DIAMETER DRAIN PIPE THROUGH THE WING WALL AS REQUIRED FOR REINFORCED BRIDGE APPROACH FILLS. SEE ROADWAY PLANS. REINFORCING STEEL IN WING WALL MAY BE SHIFTED AS NECESSARY TO CLEAR THE DRAIN PIPE.
- FOR PIPE INSERT DETAILS, SEE SUPERSTRUCTURE POT BEARINGS DETAIL SHEET.

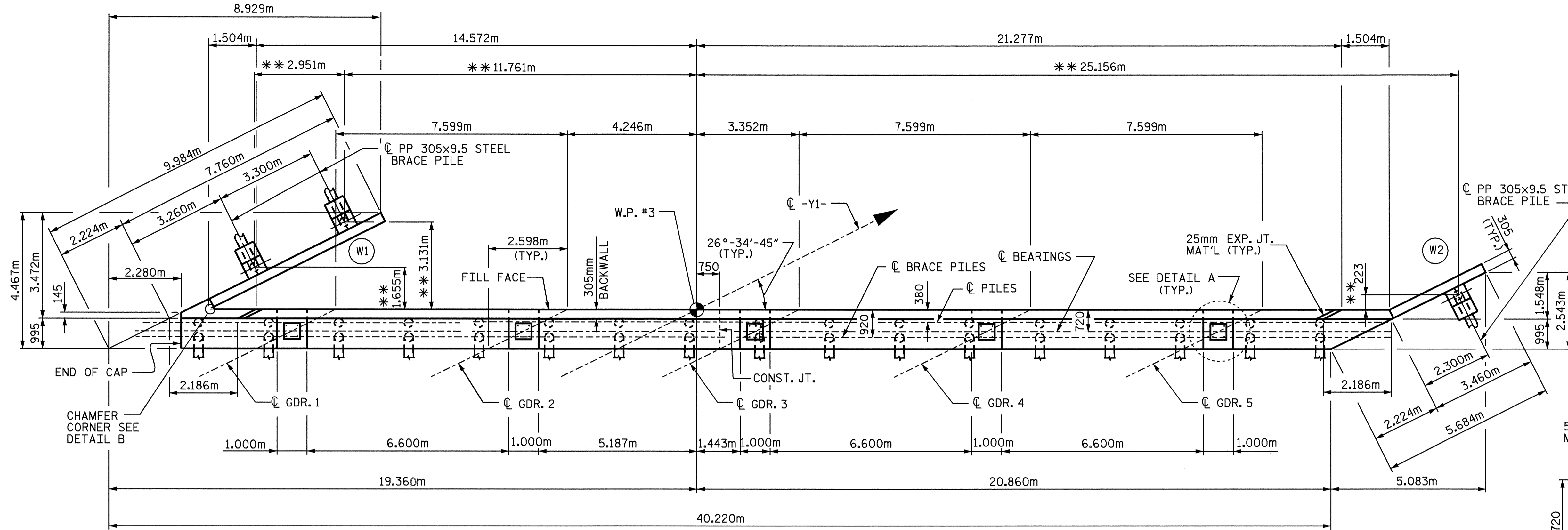

**PLAN**

\*\* DIMENSIONS LOCATING WINGWALL PILES ARE SHOWN TO THE PILES CENTERLINE AT BOTTOM OF CAP

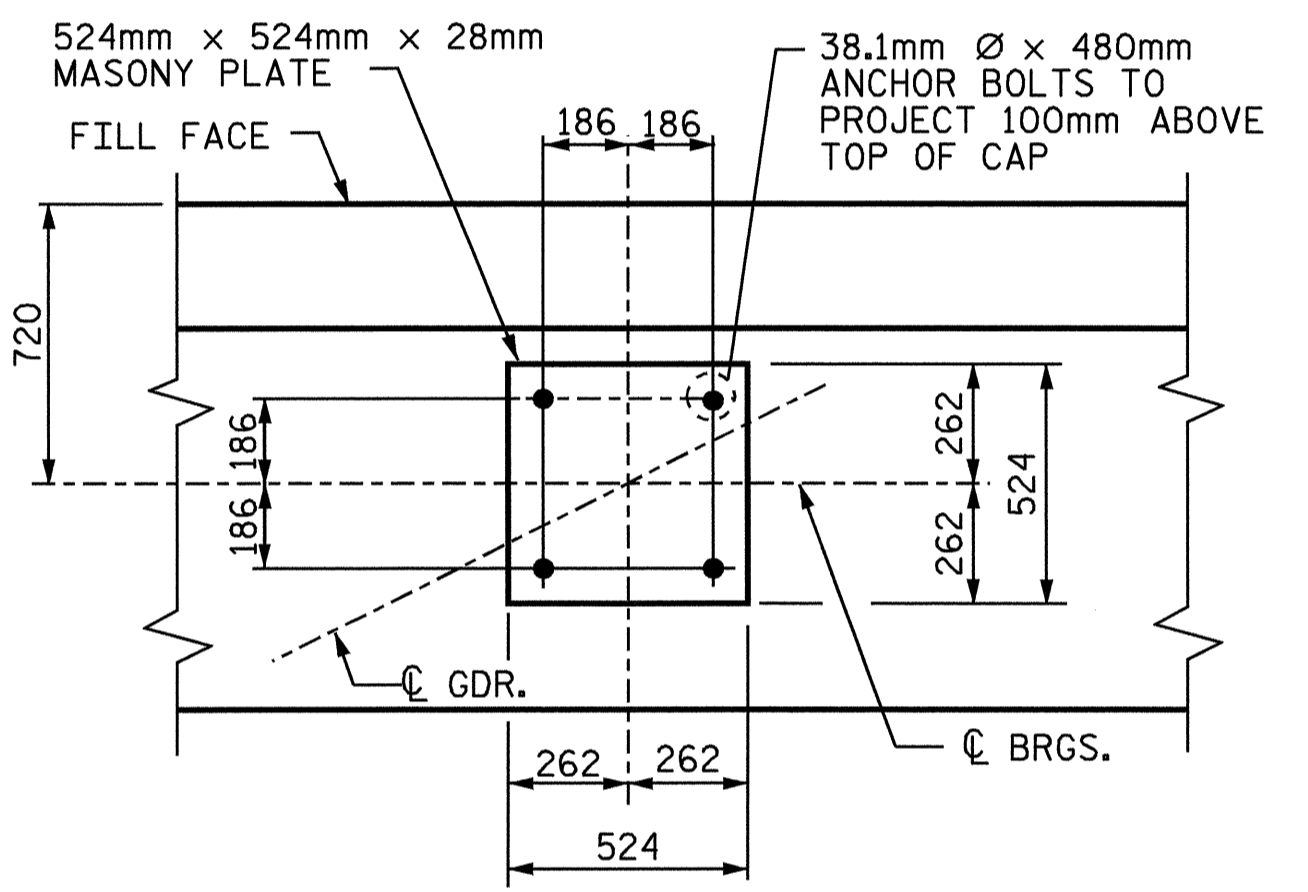

**DETAIL A**

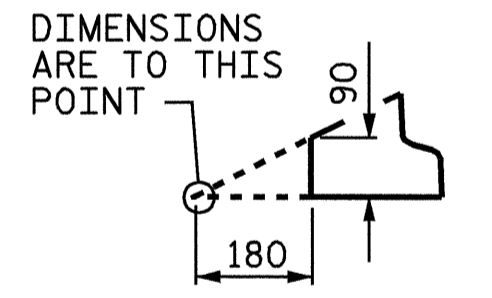

**DETAIL B**  
(CHAMFER CORNER)

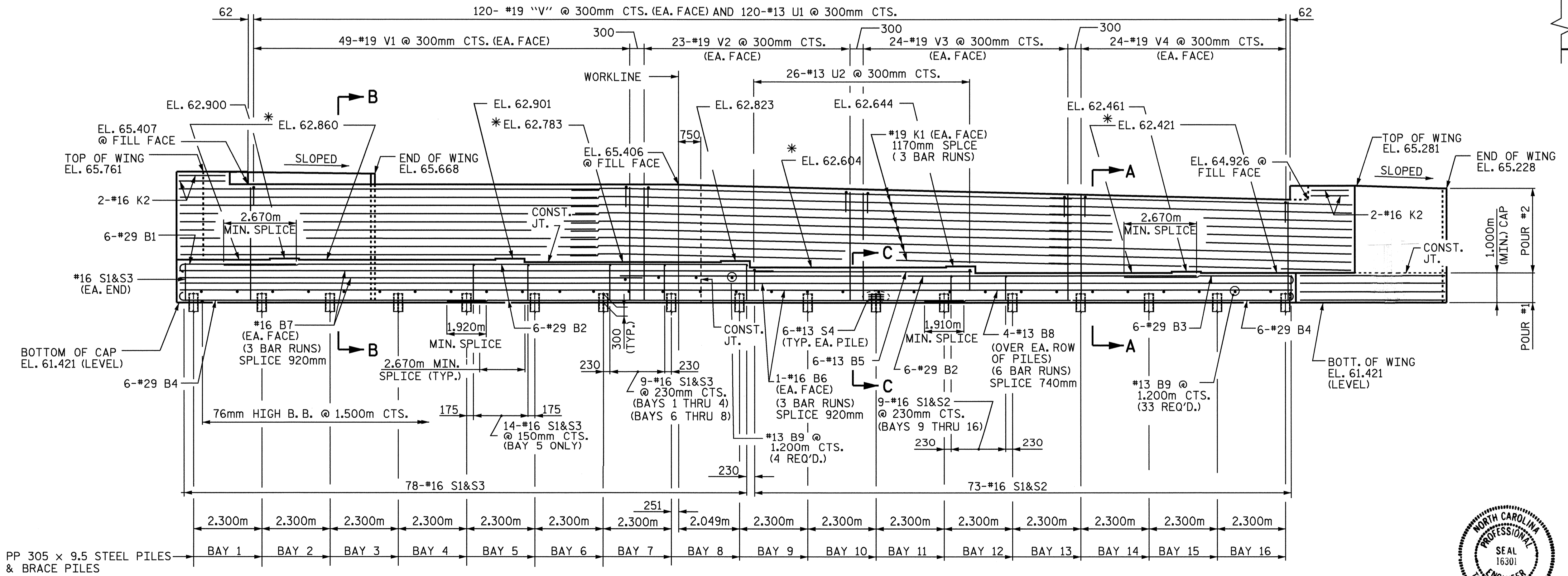

**ELEVATION**

\* FOR LOCATION OF ELEVATION BETWEEN BRIDGE SEAT BUILDUPS, SEE SECTIONS A-A AND B-B, SHEET 3 OF 3

PROJECT NO. R-513A  
ROBESON COUNTY  
 STATION: 18+64.065 -L-

SHEET 1 OF 3

STATE OF NORTH CAROLINA  
 DEPARTMENT OF TRANSPORTATION  
 RALEIGH

**SUBSTRUCTURE  
 END BENT 2**



REVISIONS						SHEET NO.	
NO.	BY:	DATE:	NO.	BY:	DATE:	S-28	
1			3			TOTAL SHEETS	
2			4			172	

DRAWN BY : N. Q. TRAN DATE : 5-20-03  
 CHECKED BY : M. A. ALLEN DATE : 3-04