

TYPICAL SECTION

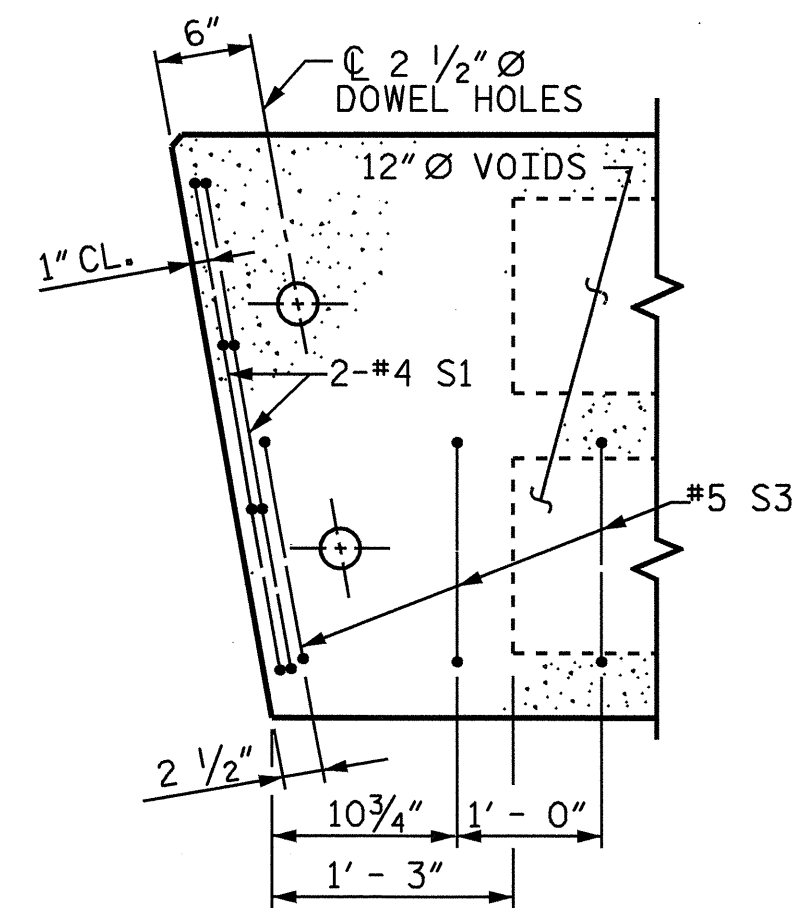

PART PLAN-EXTERIOR SECTION

NOTE: EXTERIOR SECTION SHOWN-INTERIOR SECTION SIMILAR EXCEPT OMIT S3 BARS.

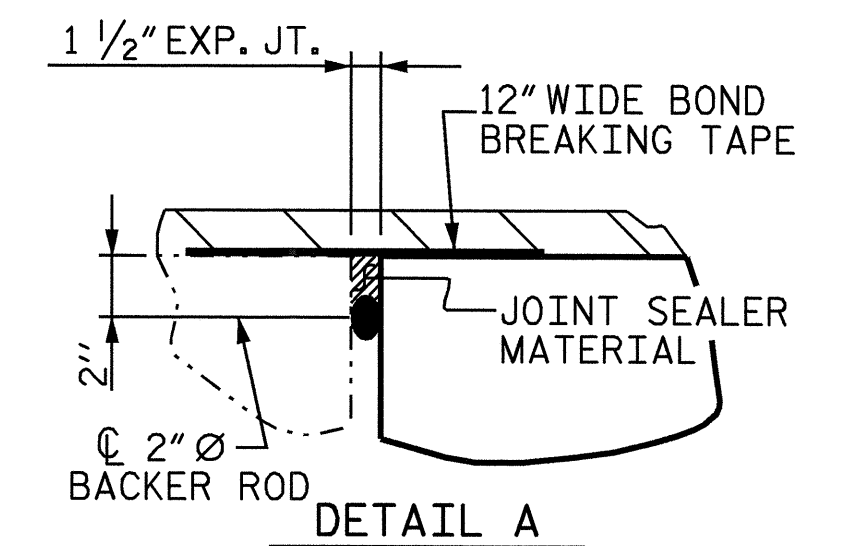

DETAIL A

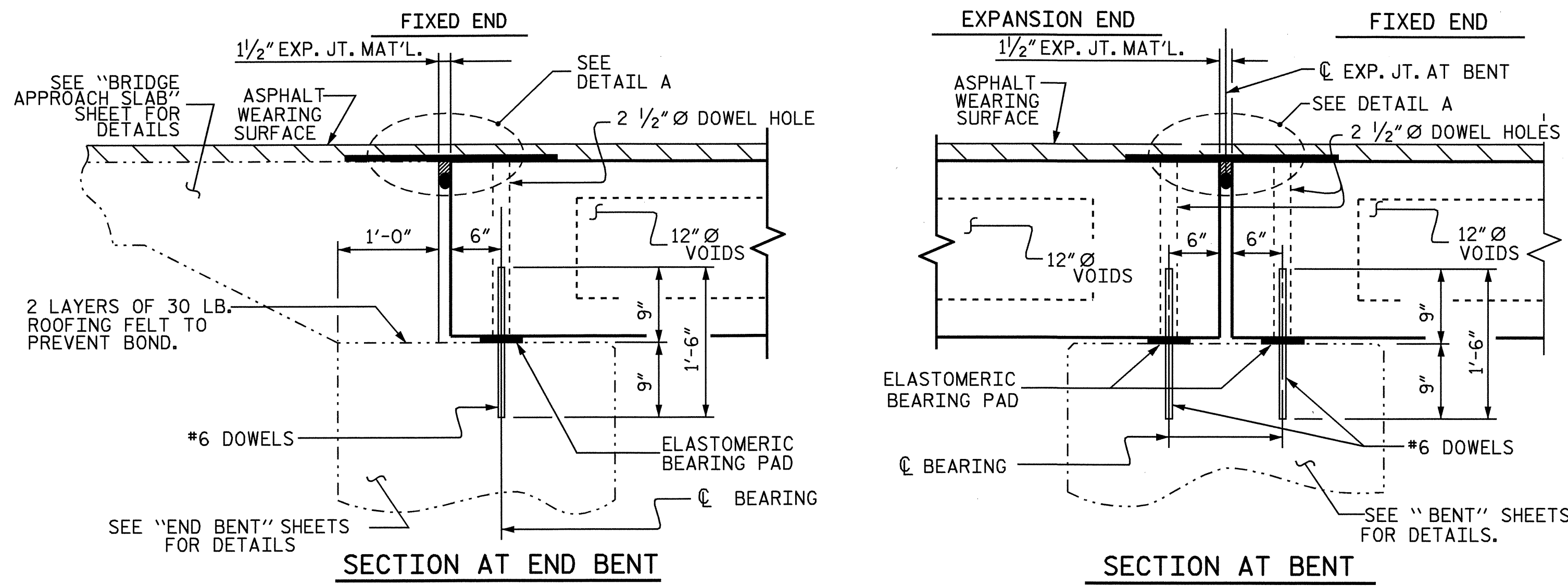

SECTION AT END BENT

SECTION AT BENT

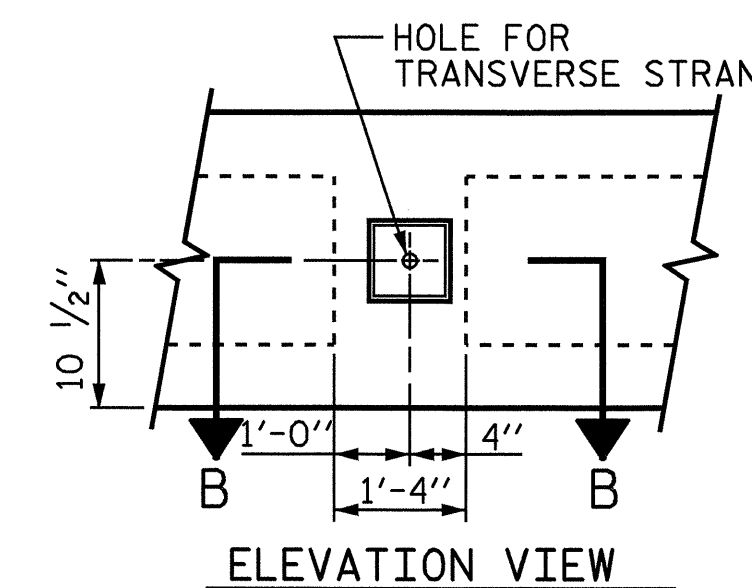

ELEVATION VIEW

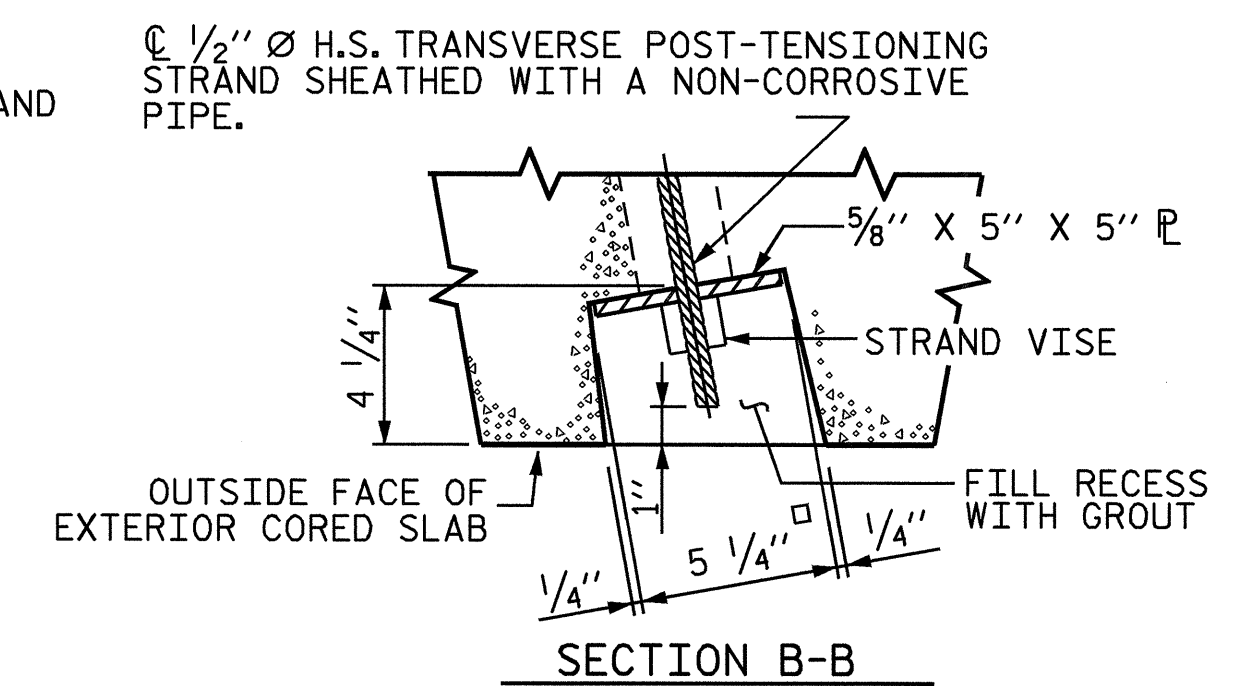

SECTION B-B

GRAUTED RECESS AT END OF POST-TENSIONED STRAND-CORED SLABS

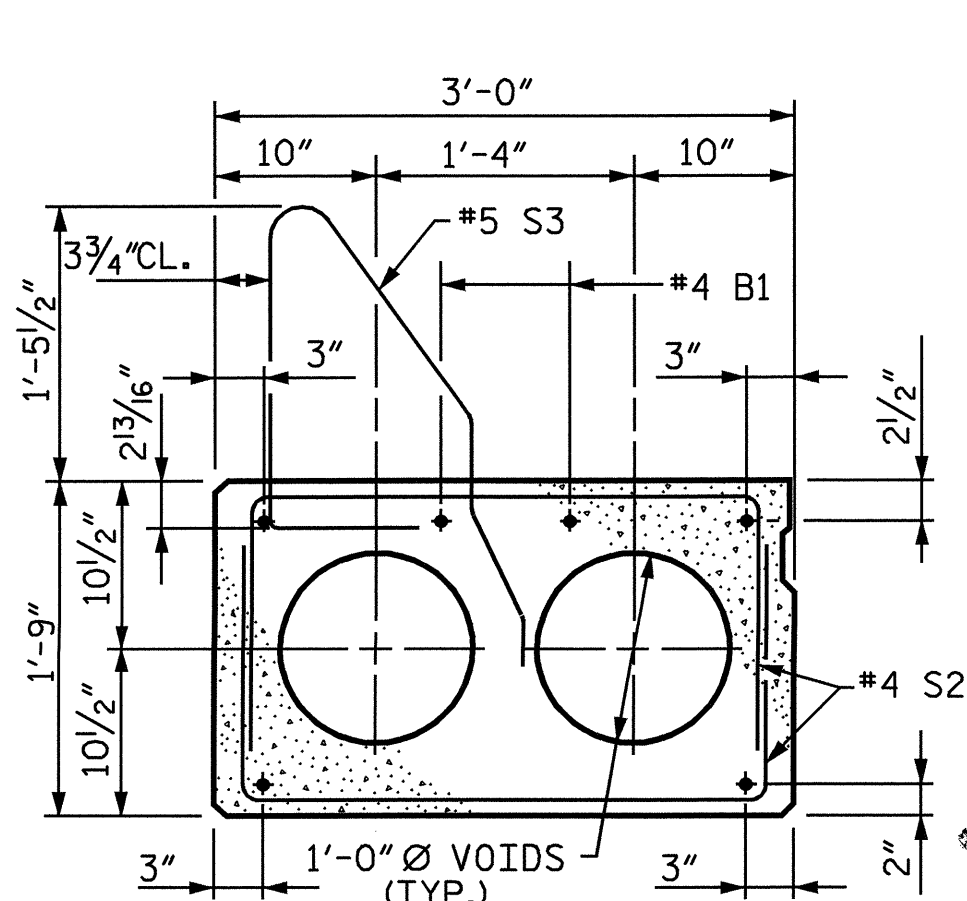

EXTERIOR SLAB SECTION

(FOR PRESTRESSED STRAND LAYOUT, SEE INTERIOR SLAB SECTION.)

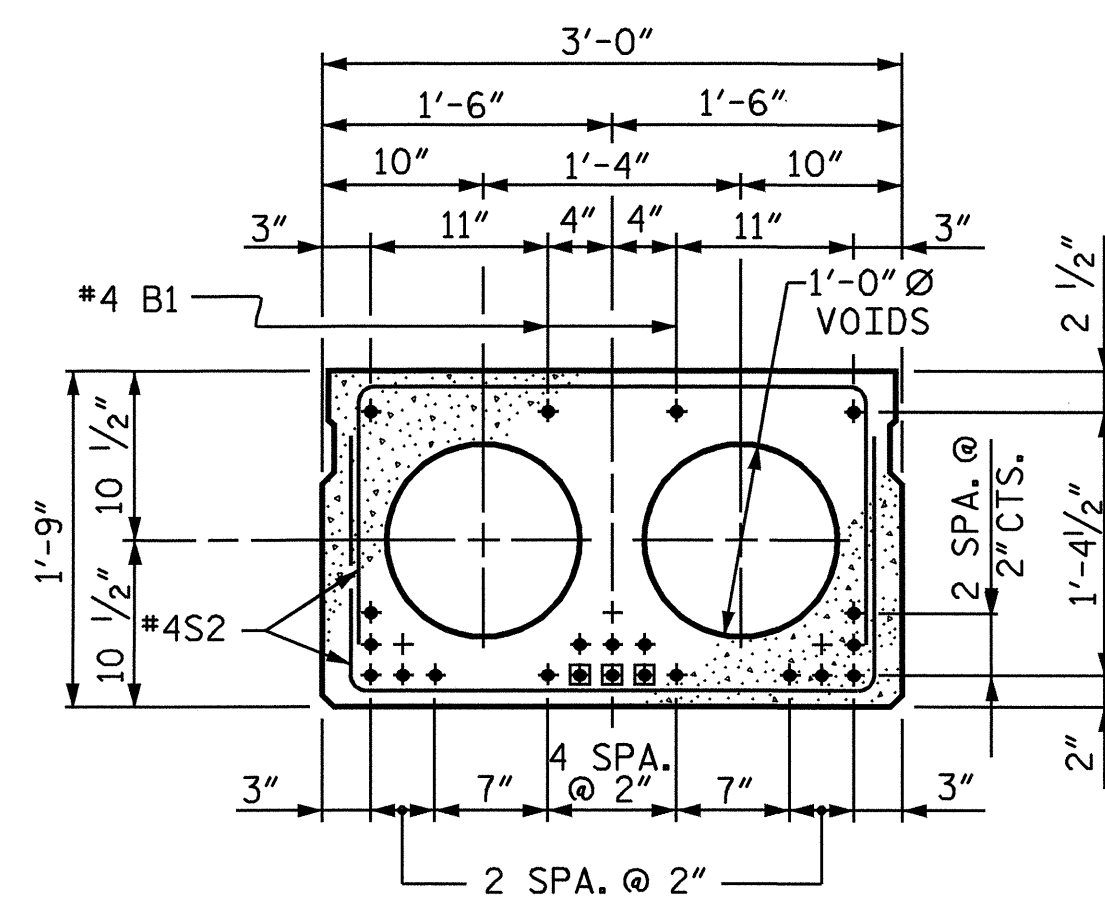

**INTERIOR SLAB SECTION
1/2" Ø LOW RELAXATION STRAND LAYOUT**

■ BOND SHALL BE BROKEN ON THESE STRANDS FOR A DISTANCE OF 4'-0" FROM END OF CORED SLAB UNIT, SEE STANDARD SPECIFICATIONS ARTICLE 1078-7.

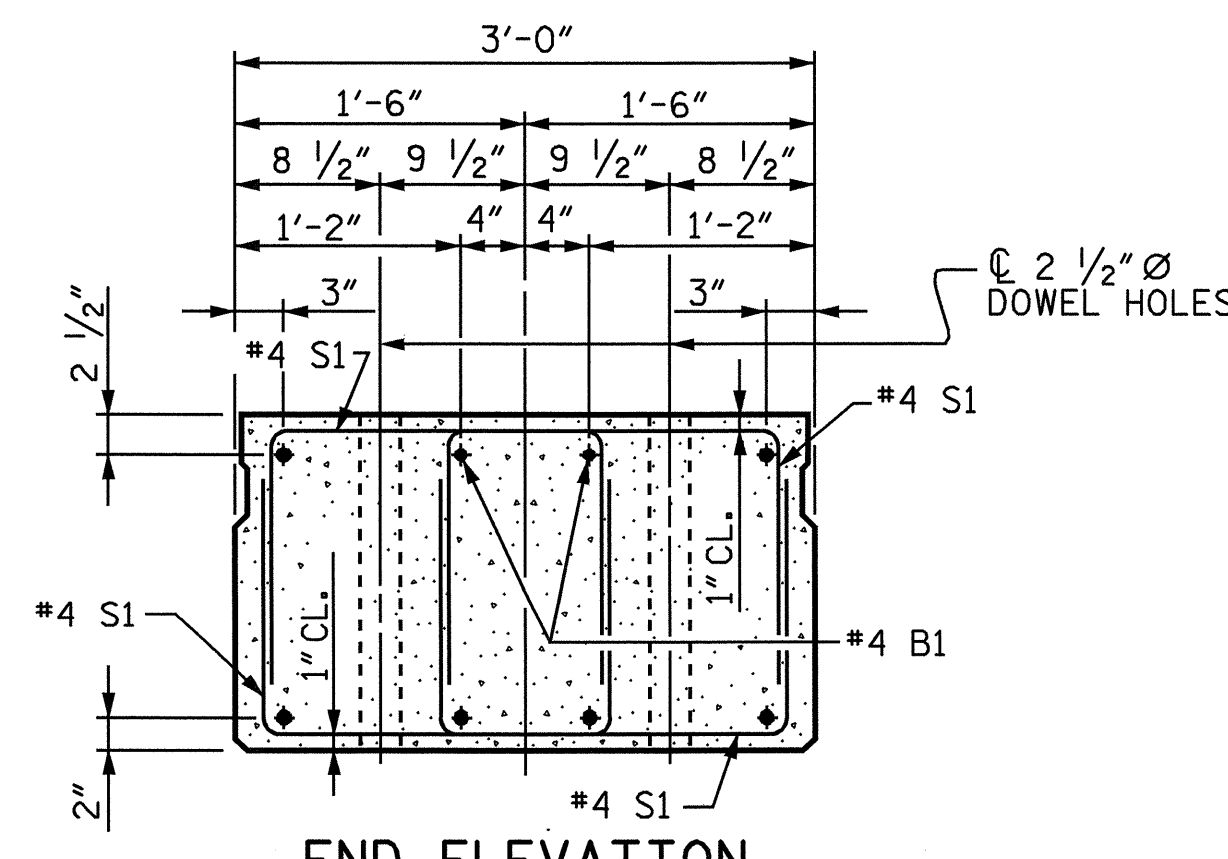

END ELEVATION

SHOWING PLACEMENT OF DOUBLE STIRRUPS AND LOCATION OF DOWEL HOLES. (STRAND LAYOUT NOT SHOWN.) INTERIOR SLAB SECTION SHOWN-EXTERIOR SLAB SECTION SIMILAR EXCEPT SHEAR KEY LOCATION.

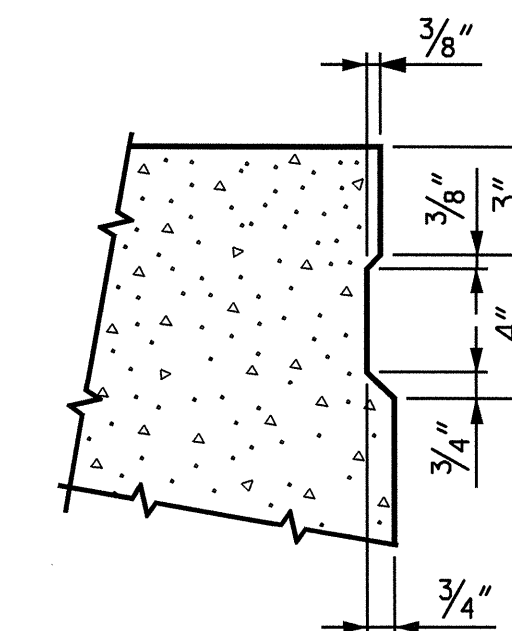

SHEAR KEY DETAIL

NOTE: OMIT SHEAR KEY ON OUTSIDE FACE OF EXTERIOR CORED SLABS.

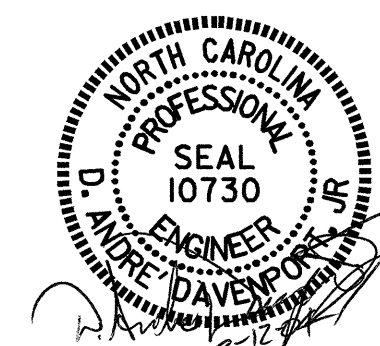

PROJECT NO. B-3879
NASH COUNTY
 STATION: 22+61.00-L-

SHEET 1 OF 6

STATE OF NORTH CAROLINA DEPARTMENT OF TRANSPORTATION RALEIGH					
3'-0" X 1'-9" PRESTRESSED CONCRETE CORED SLAB UNIT					
REVISIONS					
NO.	BY:	DATE:	NO.	BY:	DATE:
1			3		
2			4		
					SHEET NO. S-4
					TOTAL SHEETS 20

DRAWN BY: H. T. BARBOUR DATE: 3/6/04
 CHECKED BY: D. A. DAVENPORT DATE: 3/18/04