

FROM -L- STA 10+35 LT to -L- STA 11+00 LT
Front Slope: 4:1 to 6:1
W = 12'

FROM -L- STA 10+35 RT to -L- STA 12+70 RT
Front Slope: 4:1 to 6:1
W = 12'

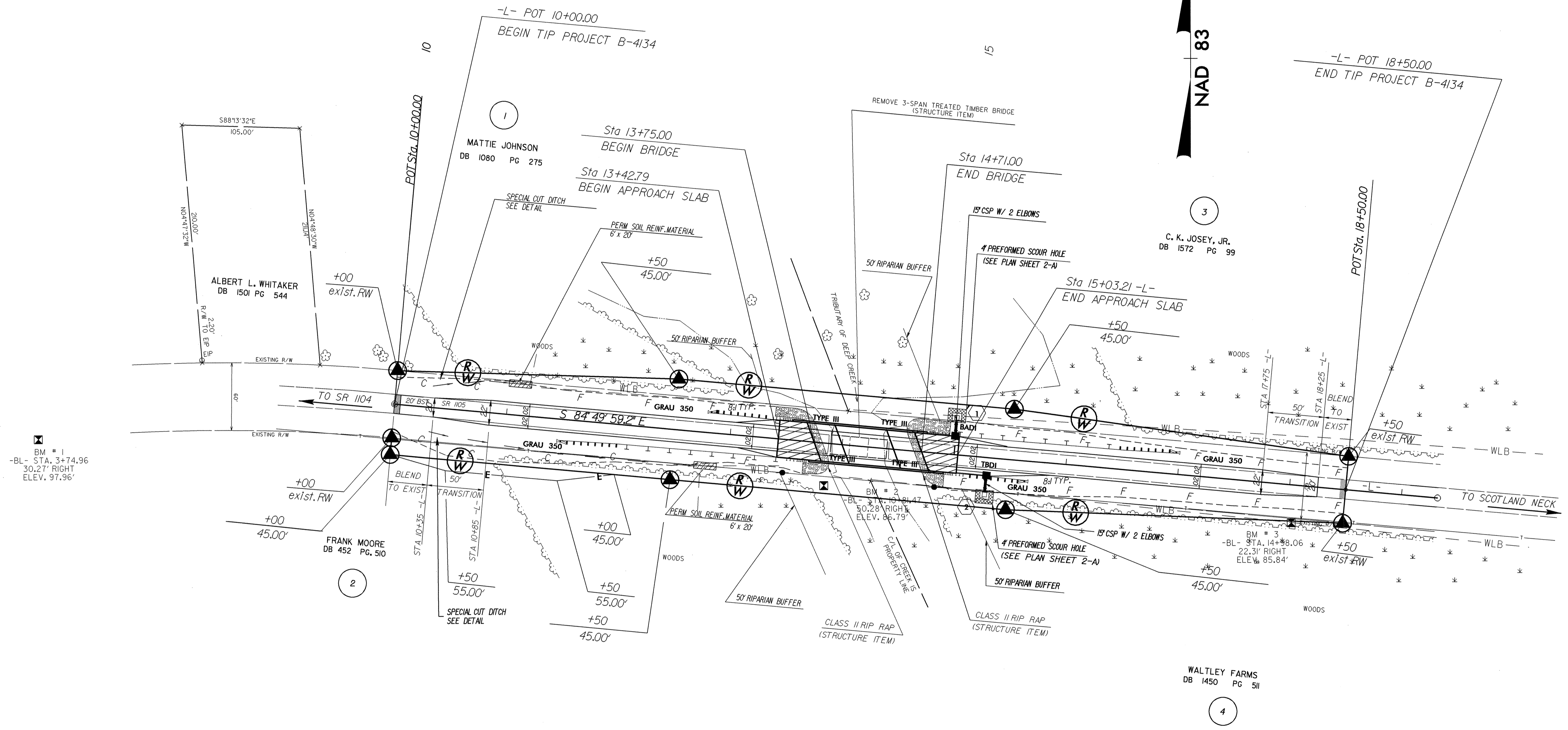
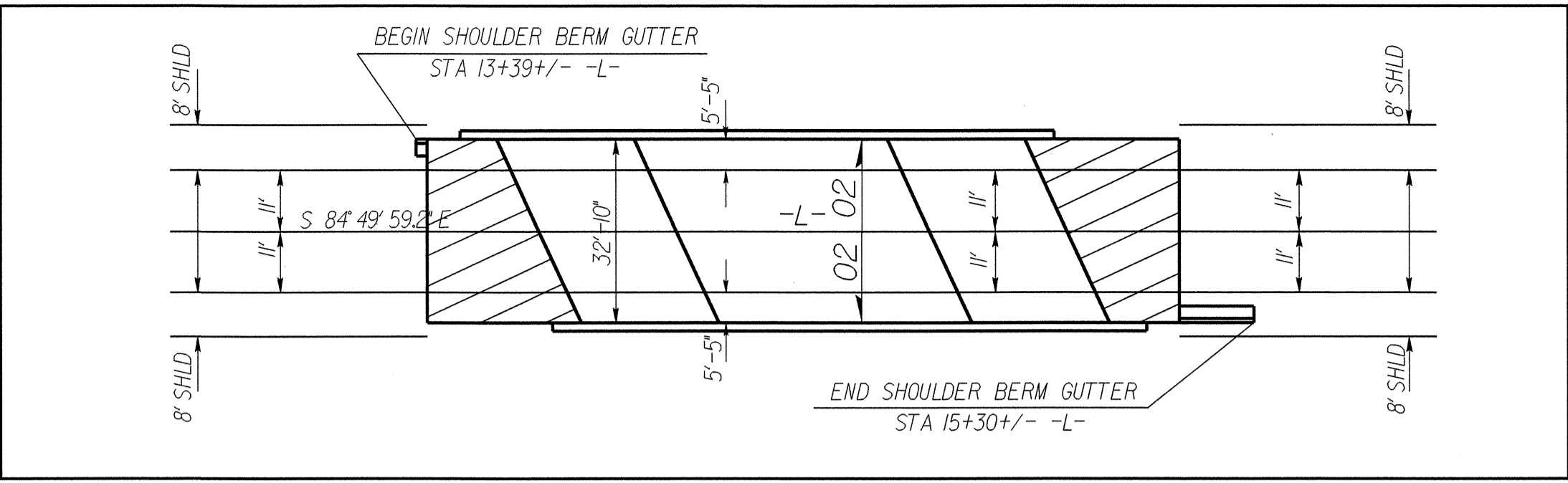

BM # 1
-BL- STA. 3+74.96
30.27' RIGHT
ELEV. 97.96'

WALTLEY FARMS
DB 1450 PG 511

SEE PLAN SHEET 5 FOR -L- PROFILE
SEE STRUCTURE PLAN SHEETS S-1 THRU S-23

5/14/99
3-AUG-2004 14:18
\\Scheffle\proj\B-4134\plans\B-4134_rdy_psh4.ms1100%.dgn
maddal..._B-4134_rdy_psh4.ms1100%.dgn