

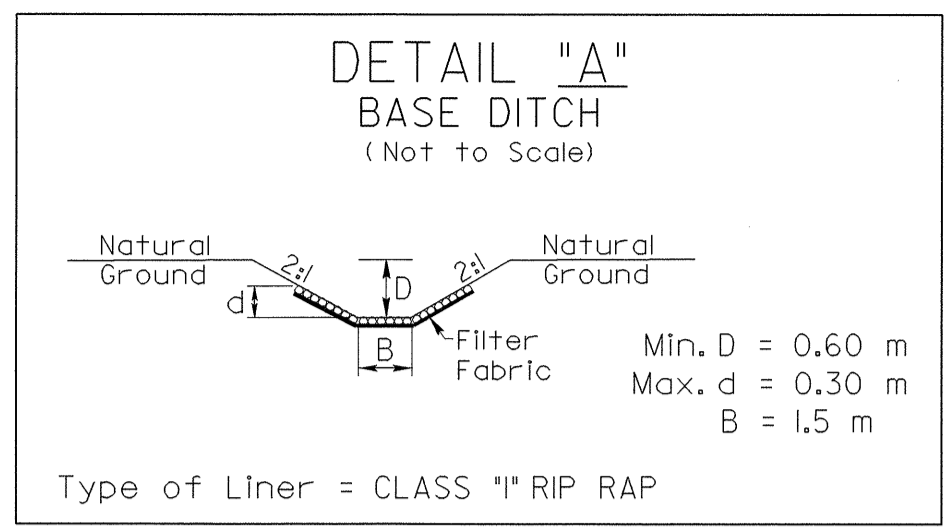

PROJECT REFERENCE NO. R-2568B		SHEET NO. 2-F
ROADWAY DESIGN ENGINEER	HYDRAULICS ENGINEER	

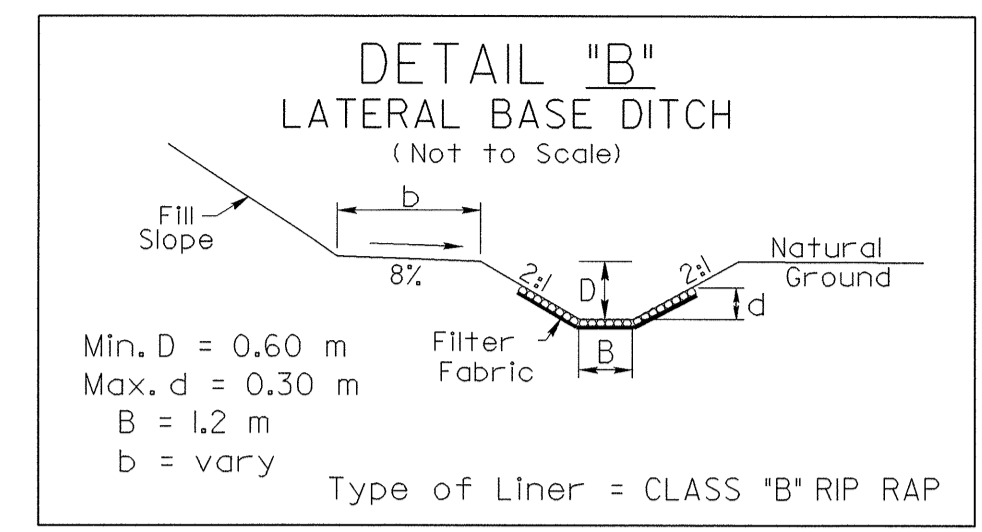

-L- STA.23+60 TO -L- STA.23+70 (LT.)



-RTLNI- STA.25+40 TO -RTLNI- STA.25+80 (RT.)

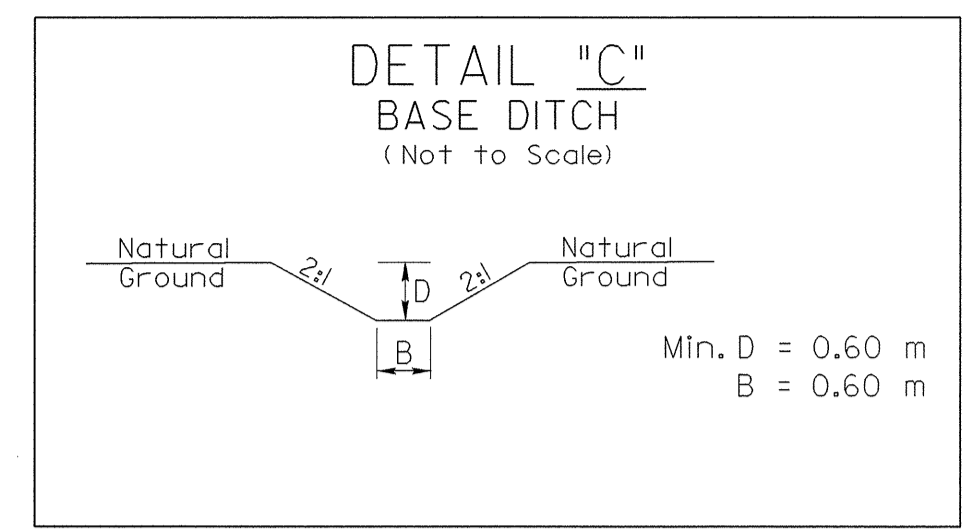

-L- STA.28+60 TO -L- STA.28+77 (LT.)  
-L- STA.65+35 (LT.)

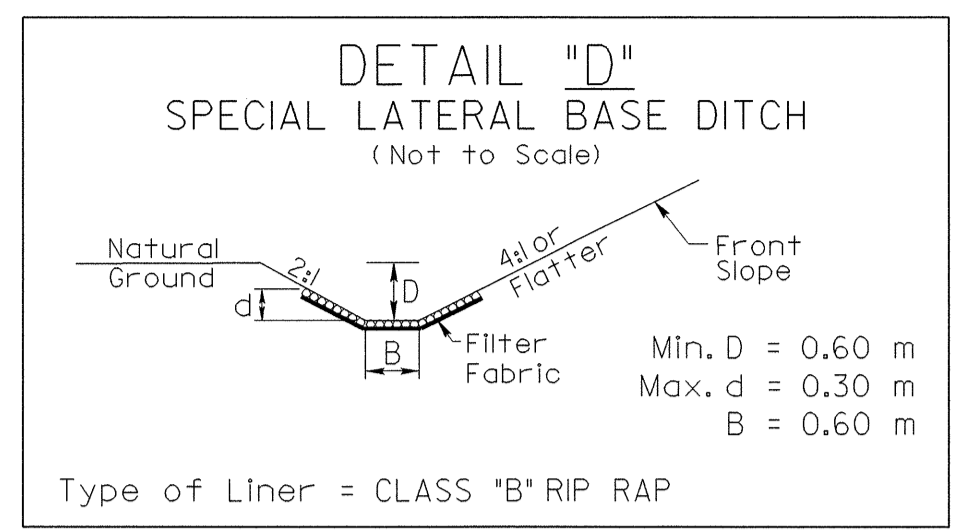

-L- STA.29+40 TO -L- STA.29+60 (RT.) Reverse Detail  
-L- STA.41+20 TO -L- STA.41+60 (LT.)  
-L- STA.75+20 TO -RTLNI- STA.76+00 (LT.)

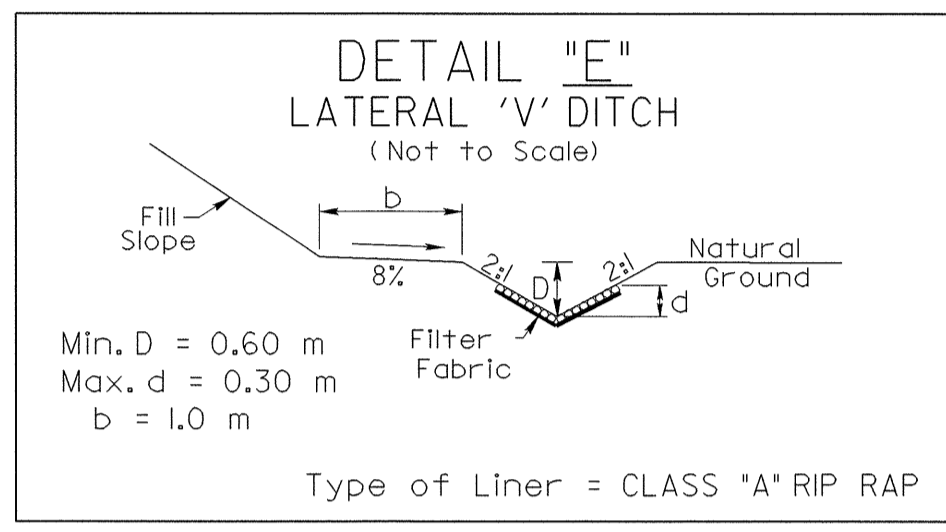

-Y- STA.10+40 TO -Y- STA.10+60 (RT.)  
-L- STA.34+00 TO -L- STA.34+40 (RT.)  
-L- STA.55+65 TO -L- STA.55+80 (RT.)

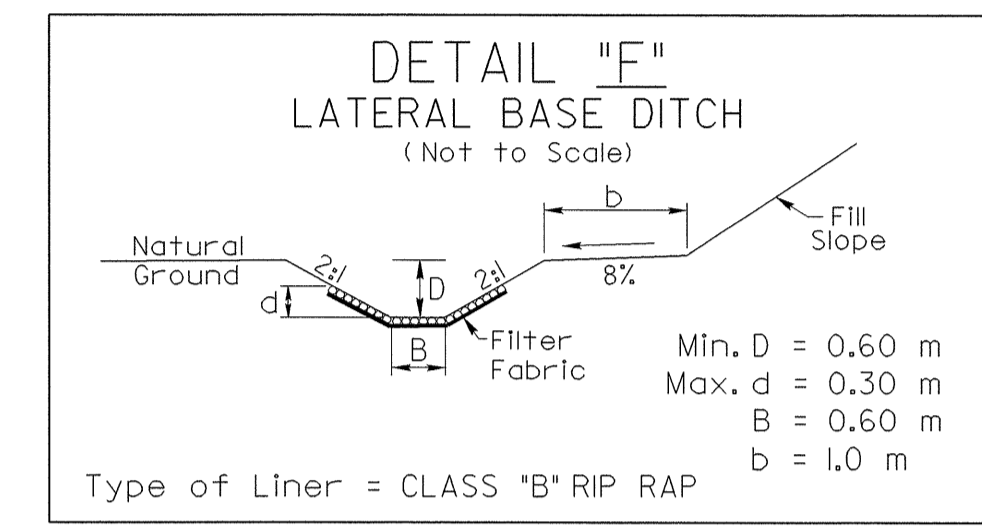

-L- STA.30+00 TO -L- STA.30+20 (RT.) Reverse Detail  
-L- STA.53+60 TO -L- STA.54+00 (LT.)  
-L- STA.75+20 TO -L- STA.75+40 (RT.) Reverse Detail  
-RTLNI- STA.76+00 TO -RTLNI- STA.76+40 (LT.)

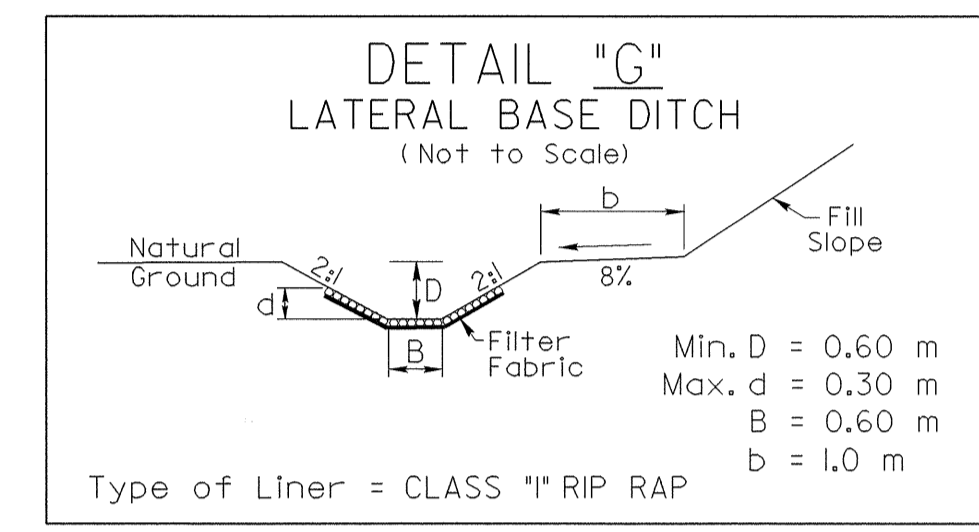

-L- STA.30+20 TO -L- STA.30+60 (RT.) Reverse Detail  
-L- STA.40+20 TO -L- STA.40+40 (RT.) Reverse Detail  
-L- STA.48+40 TO -L- STA.48+80 (LT.)

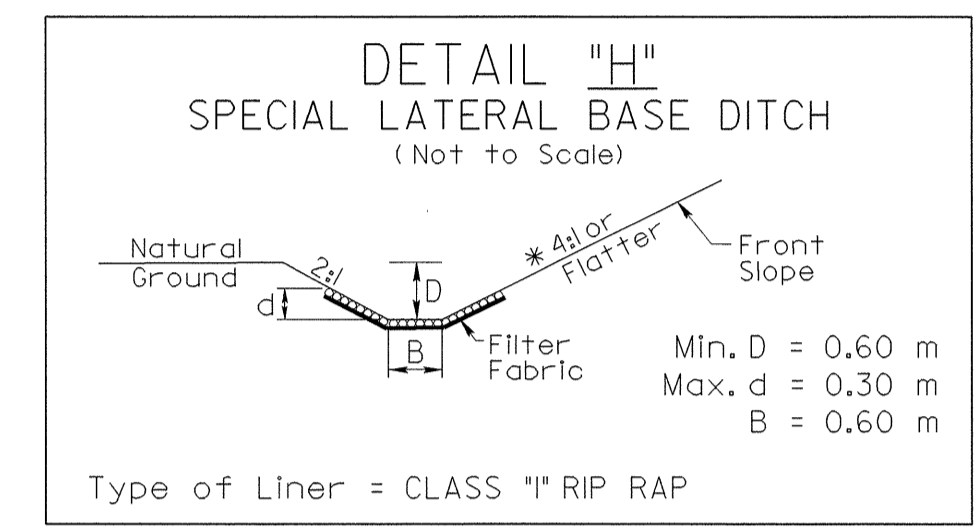

-L- STA.30+00 TO -L- STA.30+20 (LT.)  
\* -L- STA.39+60 TO -L- STA.40+20 (RT.) Reverse Detail (2:1 Slope)  
-L- STA.44+00 TO -L- STA.44+60 (RT.) Reverse Detail

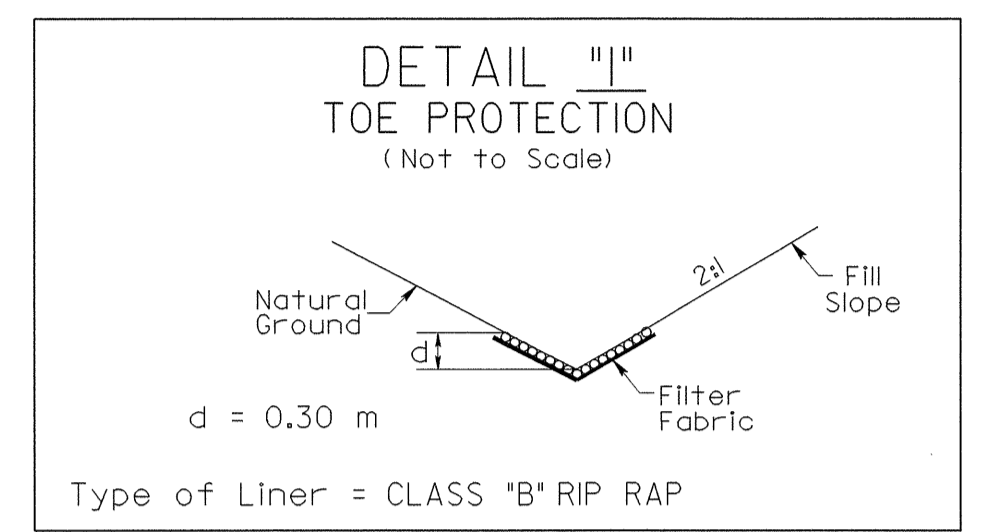

-L- STA.33+40 TO -L- STA.34+00 (RT.)  
-L- STA.33+80 TO -L- STA.34+20 (LT.)  
-L- STA.41+60 TO -L- STA.42+00 (LT.)  
-L- STA.43+70 TO -L- STA.44+40 (LT.)  
-L- STA.48+90 TO -L- STA.49+15 (RT.)  
-L- STA.50+60 TO -L- STA.51+60 (RT.)  
-L- STA.56+80 TO -L- STA.57+20 (RT.)  
-L- STA.65+00 TO -L- STA.65+60 (RT.)  
-L- STA.66+00 TO -L- STA.66+40 (RT.)

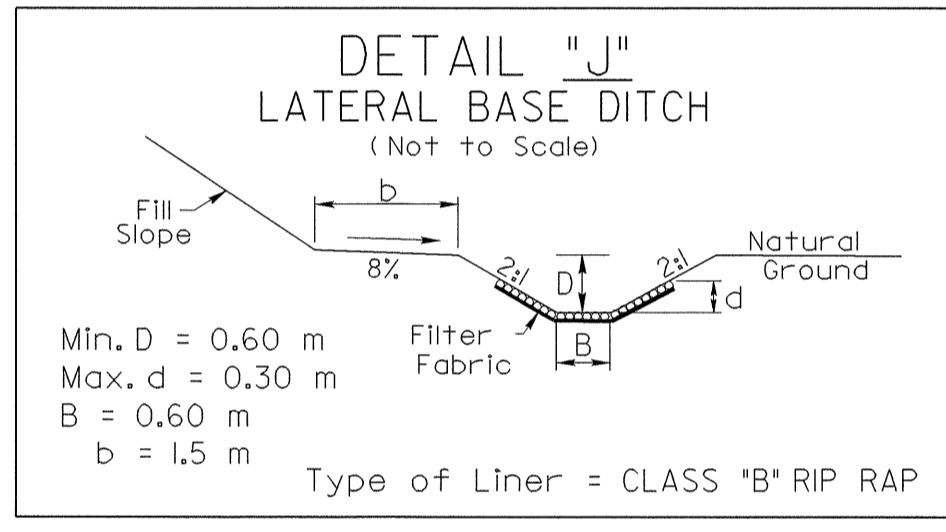

-L- STA.36+80 TO -L- STA.37+10 (RT.)  
-L- STA.60+27 TO -L- STA.60+40 (RT.)

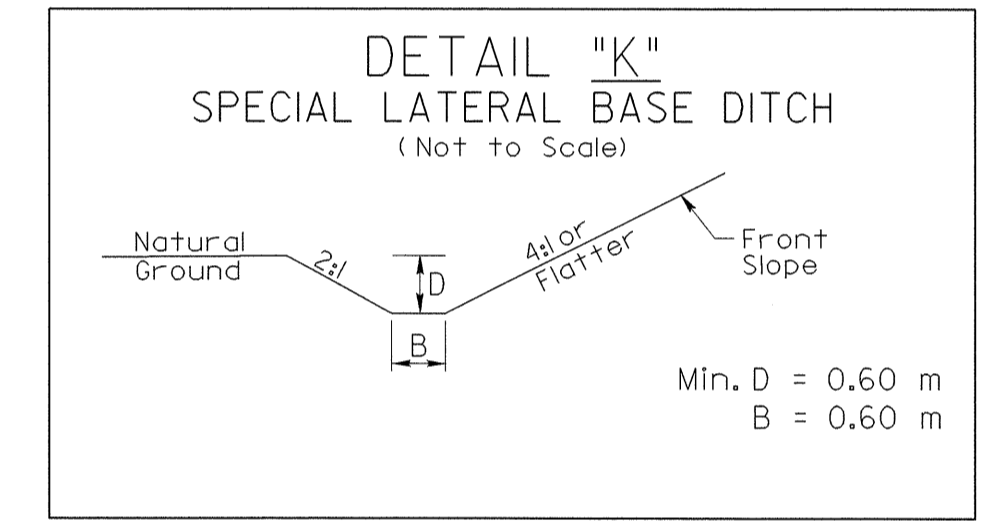

-L- STA.39+00 TO -L- STA.40+00 (LT.)  
-L- STA.61+60 TO -L- STA.63+00 (LT.)

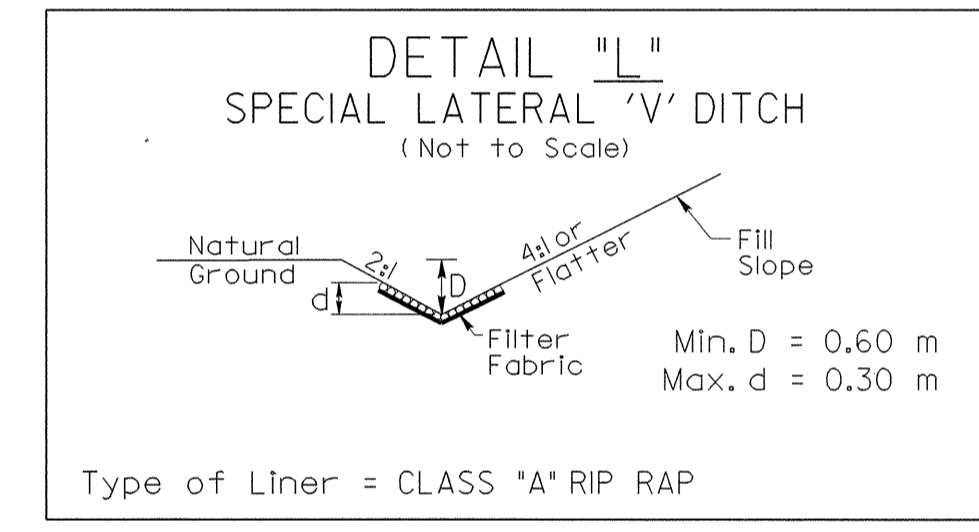

-L- STA.43+80 TO -L- STA.44+00 (RT.) Reverse Detail  
-L- STA.55+80 TO -L- STA.56+80 (RT.) Reverse Detail  
-L- STA.60+20 TO -L- STA.60+40 (LT.)  
-L- STA.67+40 TO -L- STA.67+80 (RT.) Reverse Detail  
-L- STA.71+25 TO -L- STA.71+80 (RT.) Reverse Detail  
-RTLNI- STA.75+40 TO -RTLNI- STA.76+00 (RT.) Reverse Detail

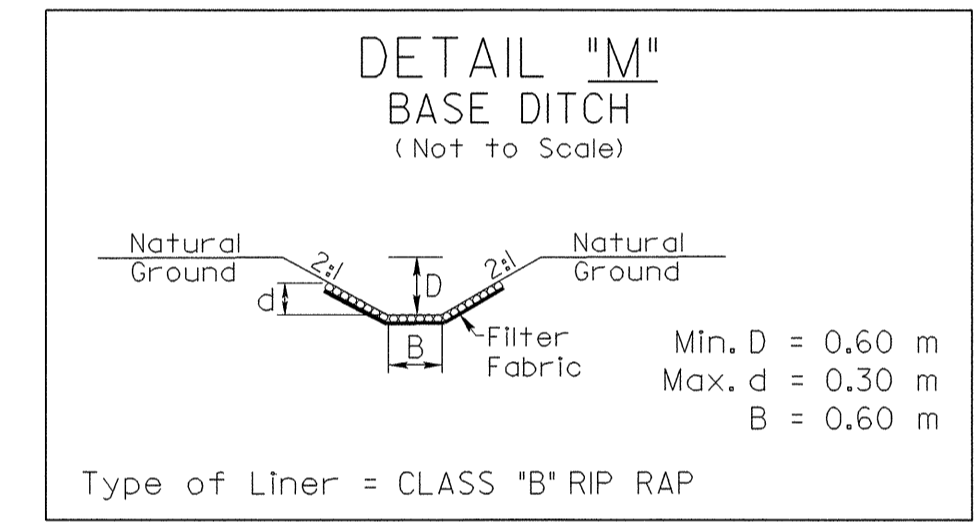

-L- STA.46+20 (LT.)  
-RTLNI- STA.78+22 TO -RTLNI- STA.78+30 (RT.)

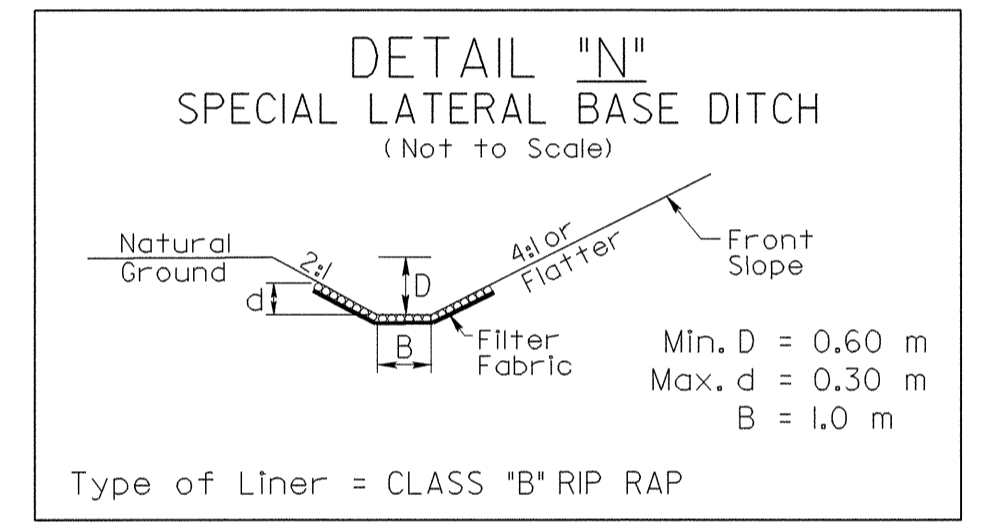

-L- STA.46+20 TO -L- STA.46+70 (LT.)

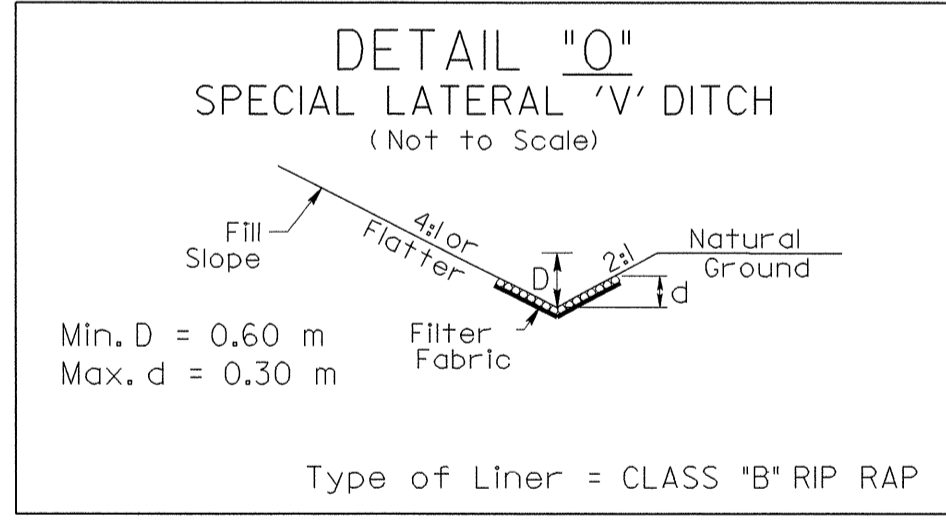

-L- STA.46+80 TO -L- STA.47+40 (RT.)  
-YI2- STA.10+28 TO -YI2- STA.10+60 (RT.)  
-RTLNI- STA.78+30 TO -RTLNI- STA.78+40 (RT.)

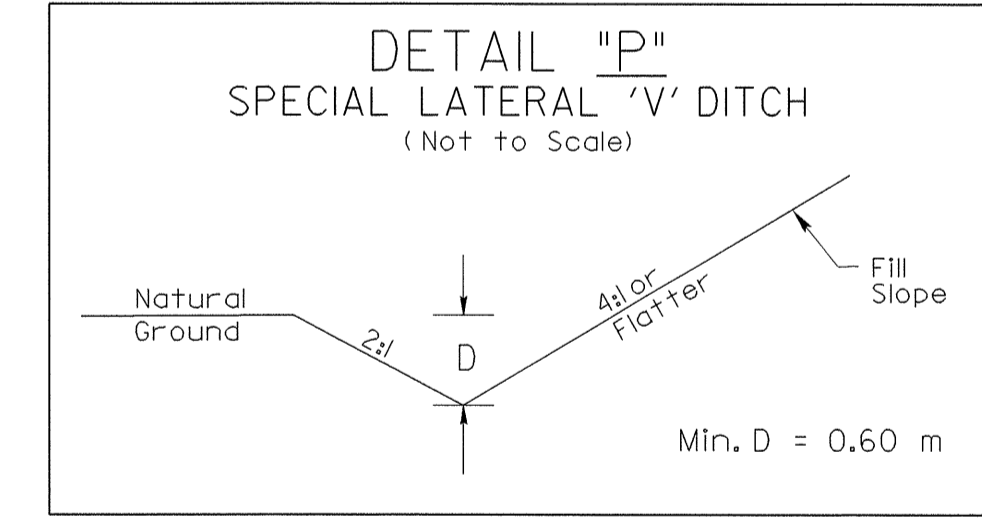

-L- STA.37+00 TO -L- STA.37+20 (LT.)  
-L- STA.47+40 TO -L- STA.47+80 (RT.) Reverse Detail

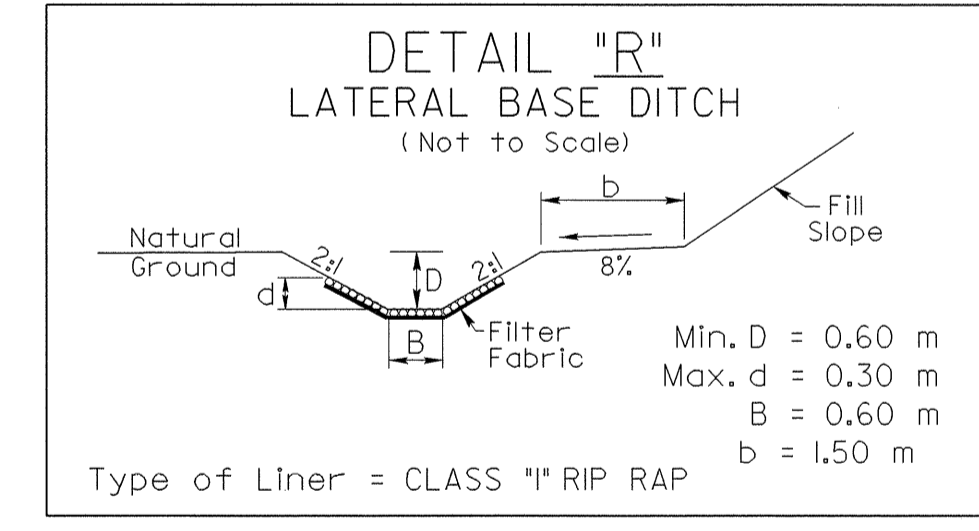

-L- STA.50+67 TO -L- STA.51+40 (LT.)

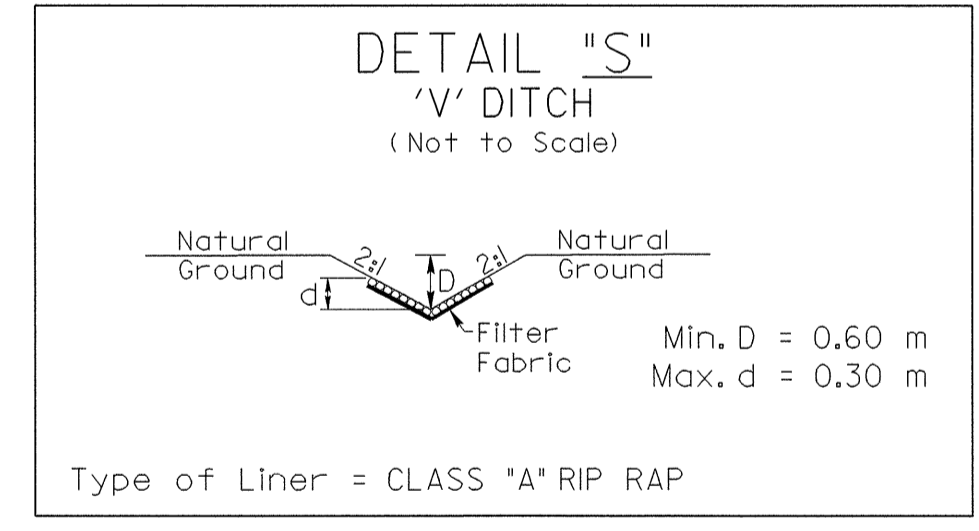

-YI0- STA.10+60 TO -YI0- STA.10+80 (RT.)  
-L- STA.74+60 TO -L- STA.74+80 (LT.)  
-YII- STA.12+85 TO -YII- STA.12+95 (LT. & RT.)

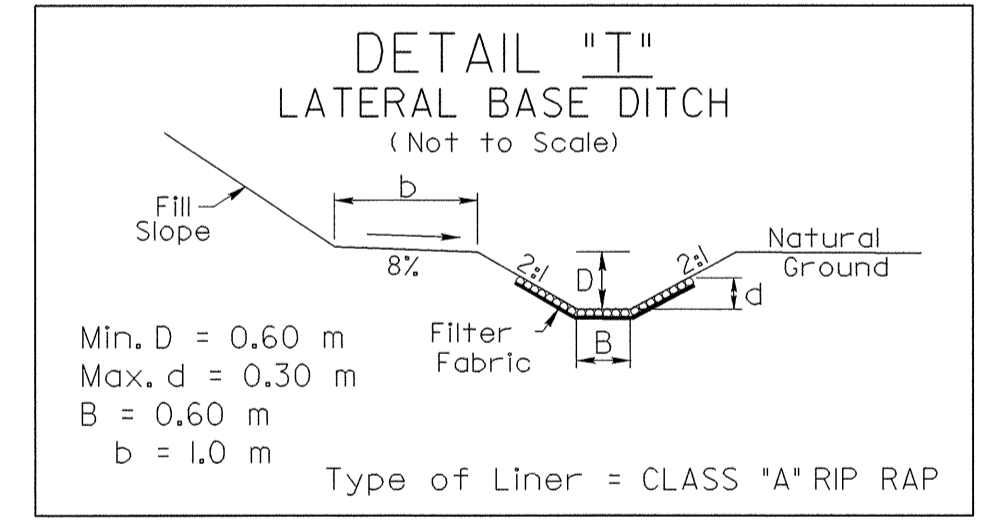

-YI0- STA.10+80 TO -YI0- STA.10+90 (RT.)

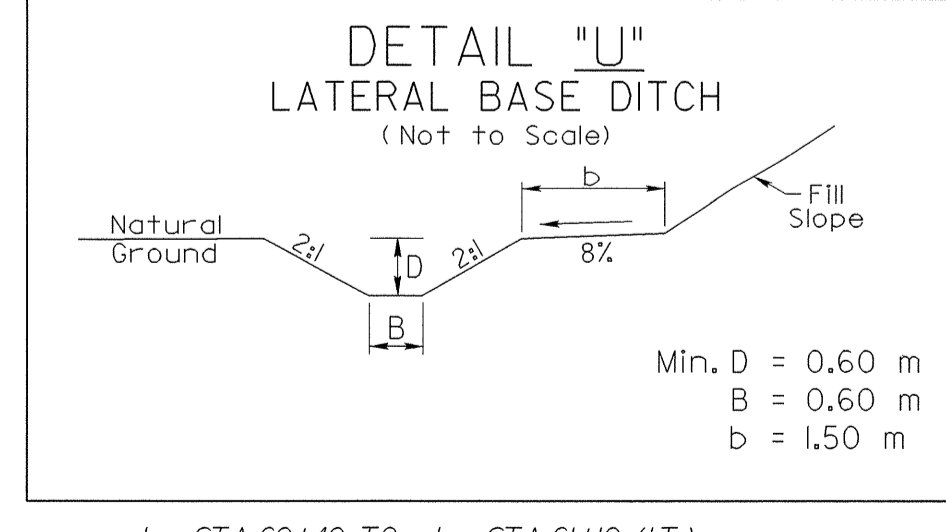

-L- STA.60+40 TO -L- STA.61+10 (LT.)  
-L- STA.60+40 TO -L- STA.61+10 (RT.) Reverse Detail

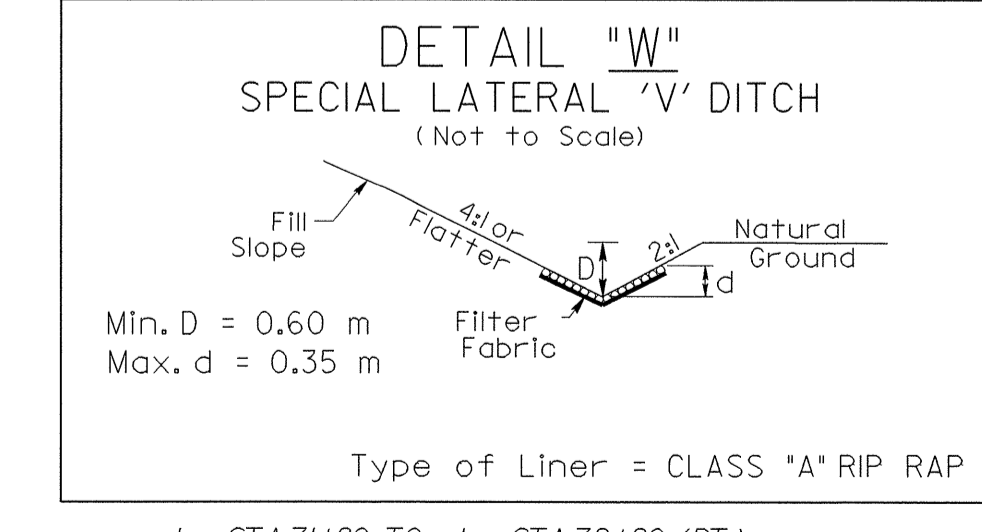

-L- STA.71+80 TO -L- STA.72+20 (RT.)  
-L- STA.73+80 TO -L- STA.74+80 (RT.)

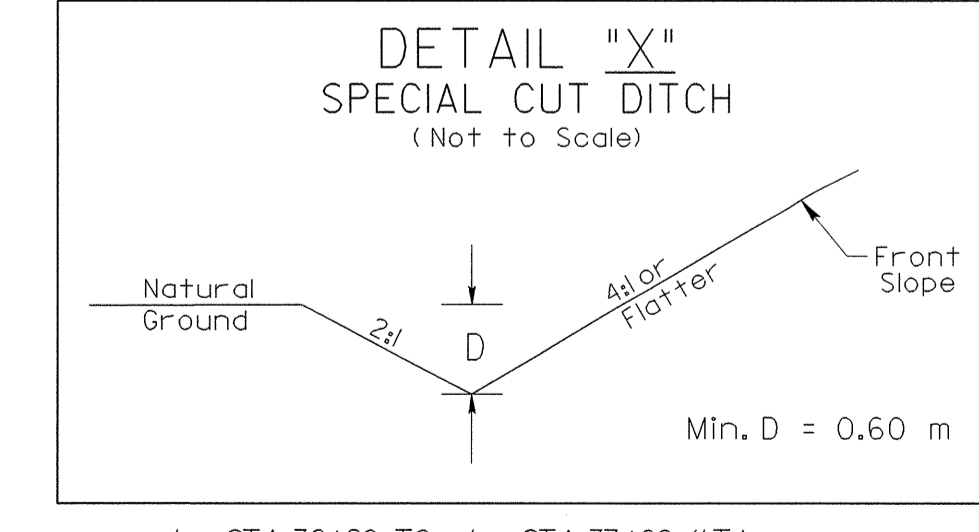

-L- STA.36+80 TO -L- STA.37+00 (LT.)  
-L- STA.51+60 TO -L- STA.52+40 (RT.) Reverse Detail  
-RTLNI- STA.78+40 TO -RTLNI- STA.79+00 (RT.) Reverse Detail  
-Y- STA.12+20 TO -Y- STA.12+60 (LT.)

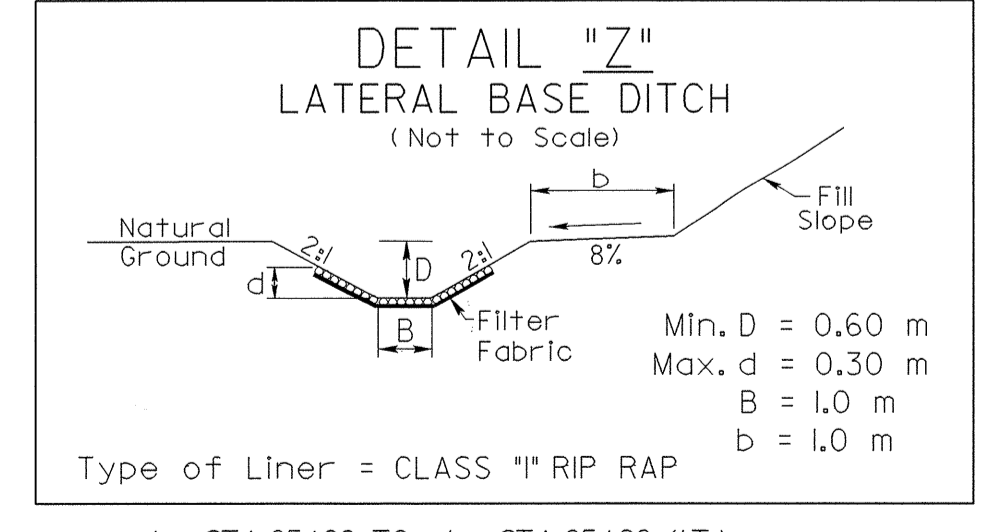
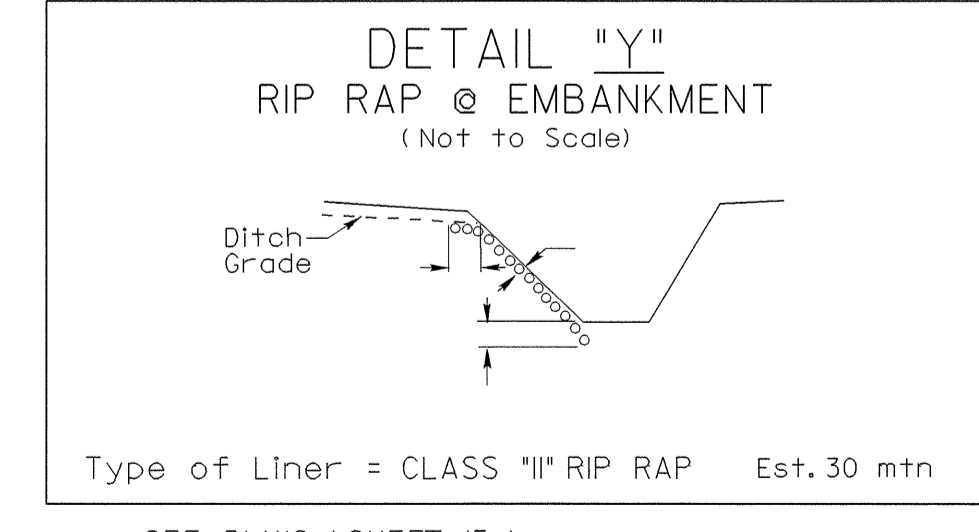

-L- STA.65+00 TO -L- STA.65+20 (LT.)