

**NOTES**

STIRRUPS IN CAP MAY BE SHIFTED AS NECESSARY TO CLEAR ANCHOR BOLTS.

FOR EPOXY PROTECTIVE COATING, SEE SPECIAL PROVISIONS.

PIPE DRAINS MAY BE SHIFTED SLIGHTLY AS NECESSARY TO CLEAR REINFORCING STEEL AND ANCHOR BOLTS.

BACKWALL SHALL BE PLACED BEFORE APPLYING THE EPOXY PROTECTIVE COATING.

THE TOP SURFACE OF THE CAP EXCEPT THE BRIDGE SEAT BUILDUPS SHALL BE SLOPED TRANSVERSELY FROM THE FILL FACE TO THE BACK FACE AT THE RATE OF 2%.

\* FOR LOCATION OF ELEVATIONS BETWEEN BRIDGE SEAT BUILDUPS, SEE SECTION A-A & SECTION B-B, SHEET 3 OF 3.

THE TOP SURFACE AREAS OF THE END BENT CAPS SHALL BE CURED IN ACCORDANCE WITH THE STANDARD SPECIFICATIONS EXCEPT THE MEMBRANE CURING COMPOUND METHOD SHALL NOT BE USED.

CONCRETE DISPLACED BY CONCRETE PILES HAS BEEN DEDUCTED FROM THE TOTAL CONCRETE QUANTITY.

THE CONTRACTOR SHALL PROVIDE FOR INSTALLATION OF THE 102mm DIAMETER DRAIN PIPE THROUGH THE WING WALL AS REQUIRED FOR REINFORCED BRIDGE APPROACH FILLS, SEE THE ROADWAY PLANS. REINFORCING STEEL IN THE WING WALL MAY BE SHIFTED AS NECESSARY TO CLEAR THE DRAIN PIPE.

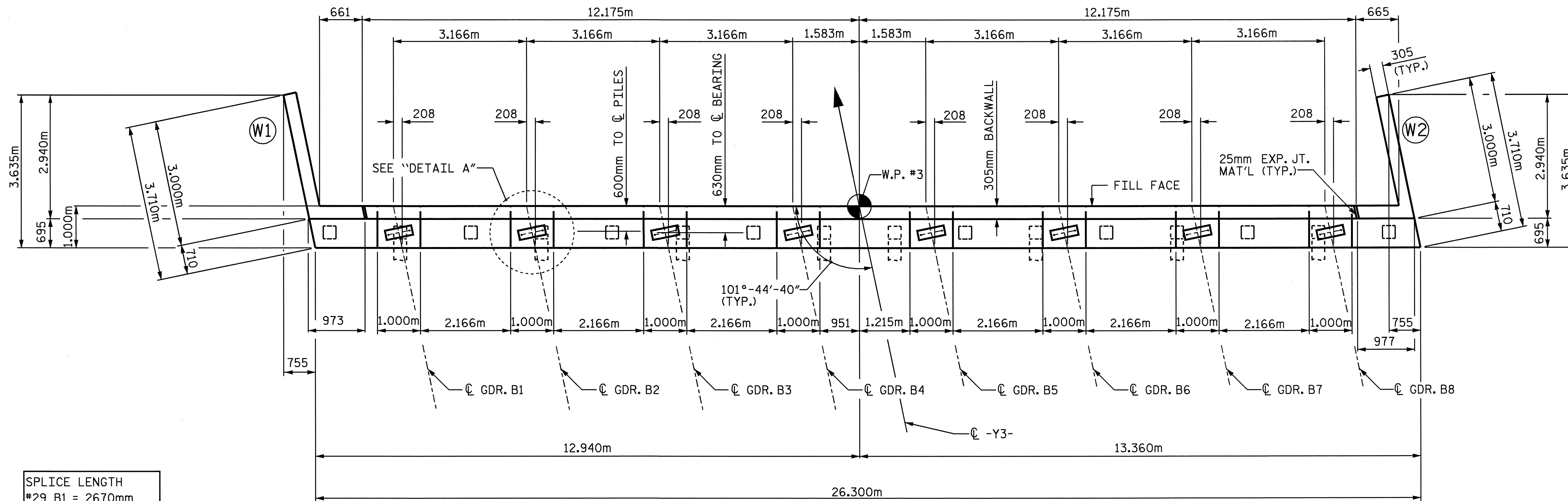

**SPLICE LENGTH**

#29 B1	= 2670mm
#29 B2	= 1910mm
#16 B3	= 920mm
#13 B4	= 740mm
#13 K1	= 740mm

**PLAN**

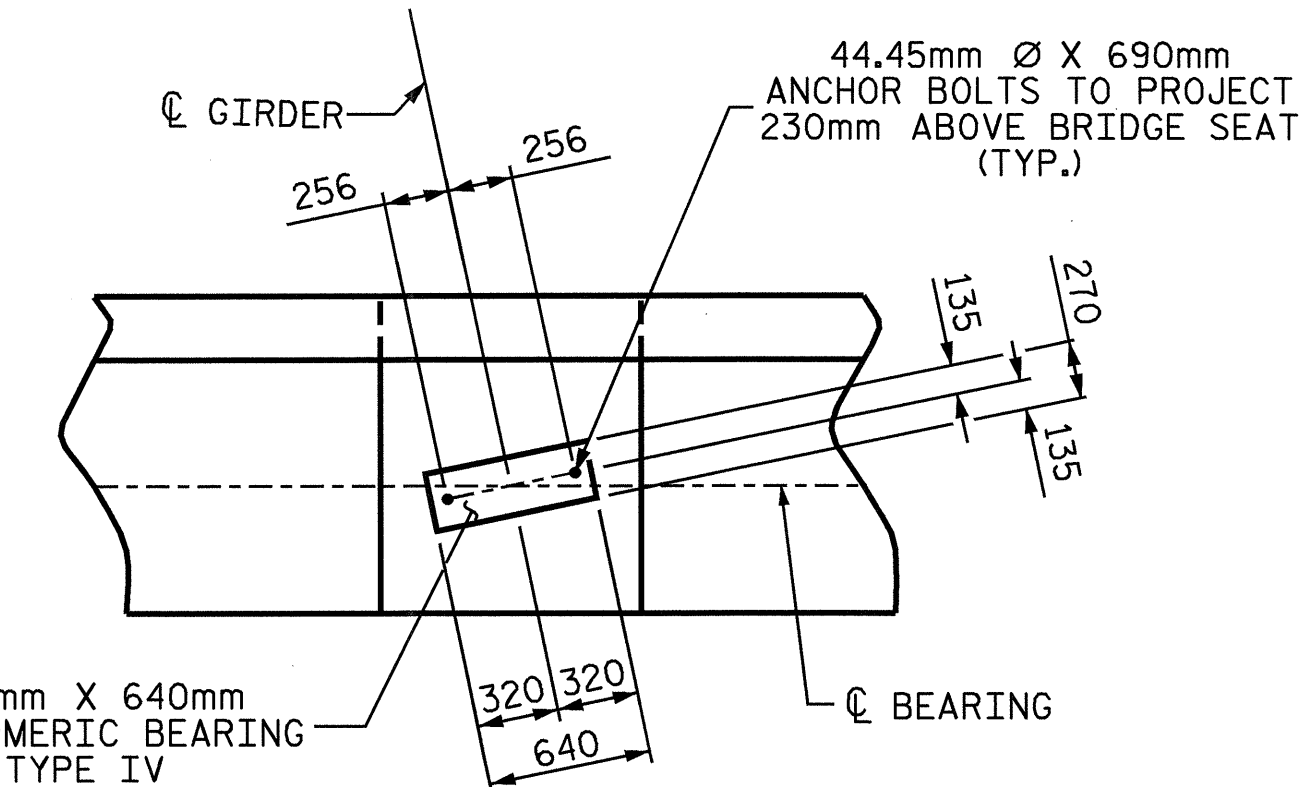

**DETAIL A**  
(TYP. EA. GIRDER)

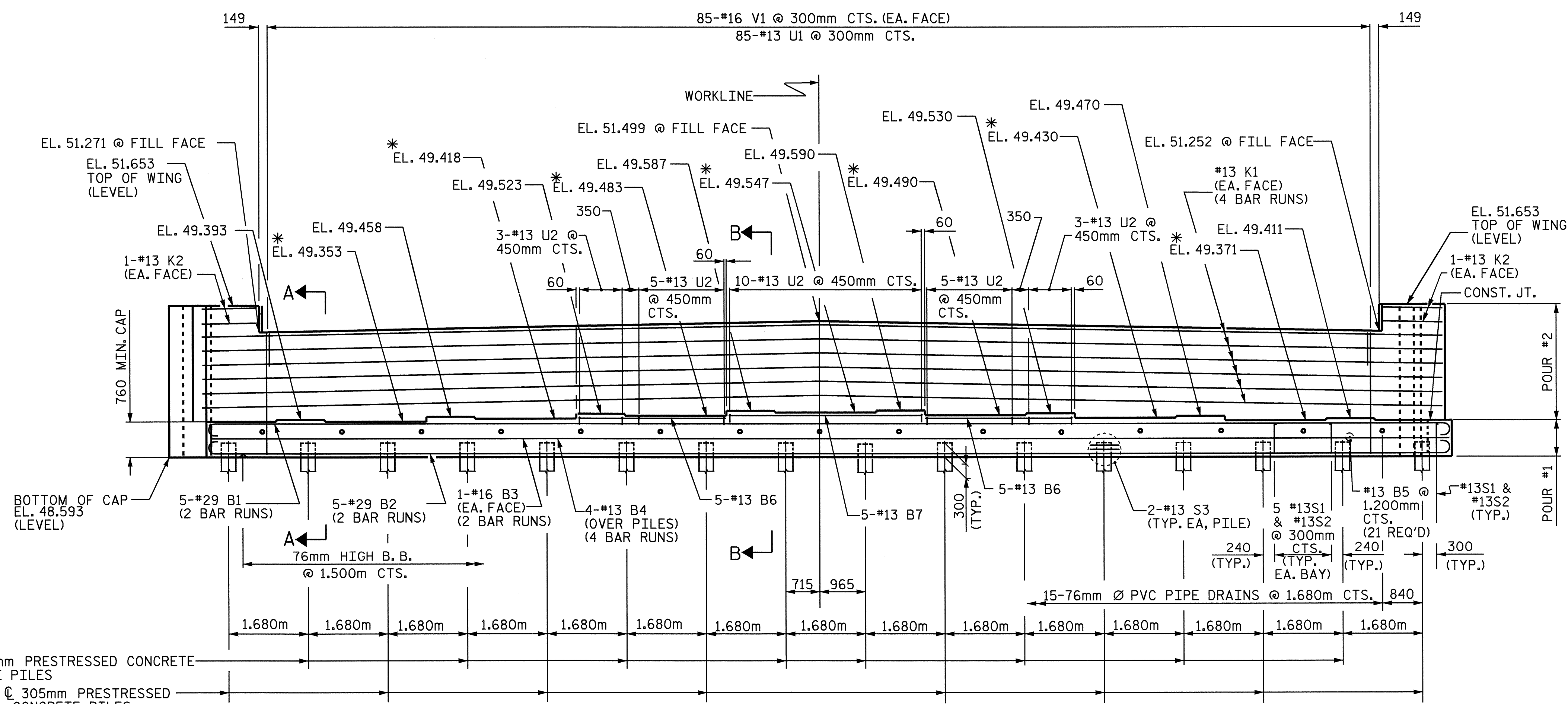

**ELEVATION**

PROJECT NO. **R-513C**  
**ROBESON** COUNTY  
 STATION: **298+57.237 -L-**

SHEET 1 OF 3

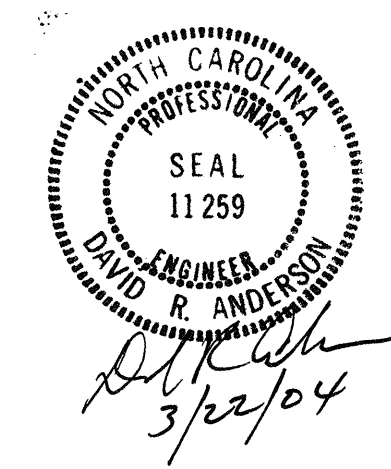

STATE OF NORTH CAROLINA  
 DEPARTMENT OF TRANSPORTATION  
 RALEIGH

**SUBSTRUCTURE**  
**END BENT 2**

REVISIONS						SHEET NO.
NO.	BY:	DATE:	NO.	BY:	DATE:	5-271
1			3			TOTAL SHEETS
2			4			312

DRAWN BY: S. M. RASHIDI DATE: 8/01/02  
 CHECKED BY: K. P. SEDAI DATE: 8/16/02