

NOTES

WHEN COMPRESSION JOINT SEAL OR EVAZOTE JOINT SEAL IS REQUIRED, THE JOINT IN THE DECK SHALL BE SAWED PRIOR TO THE CASTING OF BARRIER RAIL.

ALL REINFORCING STEEL IN BARRIER RAILS SHALL BE EPOXY COATED.

THE #16S3 THRU #16S4 BARS SHALL BE INSTALLED, USING AN ADHESIVE ANCHORING SYSTEM, AFTER SAWING THE JOINT. FOR ADHESIVELY ANCHORED ANCHOR BOLTS OR DOWELS, SEE SPECIAL PROVISIONS. THE YIELD LOAD FOR THE #16 S3 THRU #16 S6 BARS IS 82.7 KN. FIELD TESTING FOR THE ADHESIVE BONDING SYSTEM IS NOT REQUIRED.

VERTICAL GROOVED CONTRACTION JOINTS, 12mm IN DEPTH, SHALL BE TOOLED IN ALL EXPOSED FACES OF THE BARRIER RAIL AND IN ACCORDANCE WITH ARTICLE 825-10(B) OF THE STANDARD SPECIFICATIONS. A JOINT SHALL BE LOCATED AT EACH THIRD POINT BETWEEN BARRIER RAIL EXPANSION JOINTS. ONLY ONE JOINT IS REQUIRED AT MIDPOINT OF BARRIER RAIL SEGMENTS LESS THAN 6.100m IN LENGTH AND NO JOINTS ARE REQUIRED FOR THOSE SEGMENTS LESS THAN 3.500m IN LENGTH.

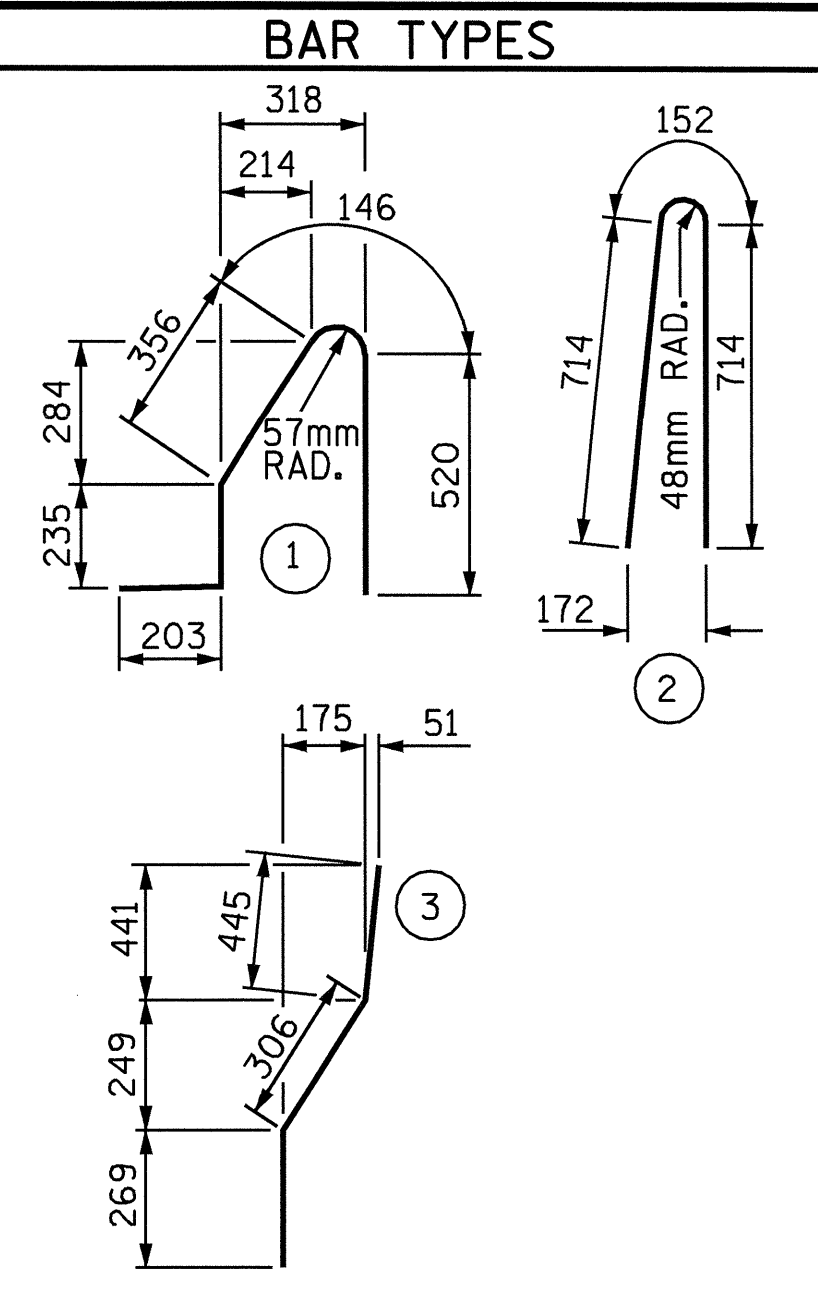

ALL BAR DIMENSIONS ARE OUT TO OUT

BILL OF MATERIAL

FOR CONCRETE BARRIER RAIL ONLY

BAR	NO.	SIZE	TYPE	LENGTH	WEIGHT
* B1	28	#16	STR	4580	199
* B2	84	#16	STR	8000	1043
* B3	28	#16	STR	4340	189
* S1	418	#16	1	1460	947
* S2	418	#16	2	1580	1025
* S3	12	#16	3	1020	19
* S4	12	#16	STR	960	18

* EPOXY COATED REINFORCING STEEL 3440 kg

CLASS AA CONCRETE 30.5 CU. METER

CONCRETE BARRIER RAIL 129.3 METERS

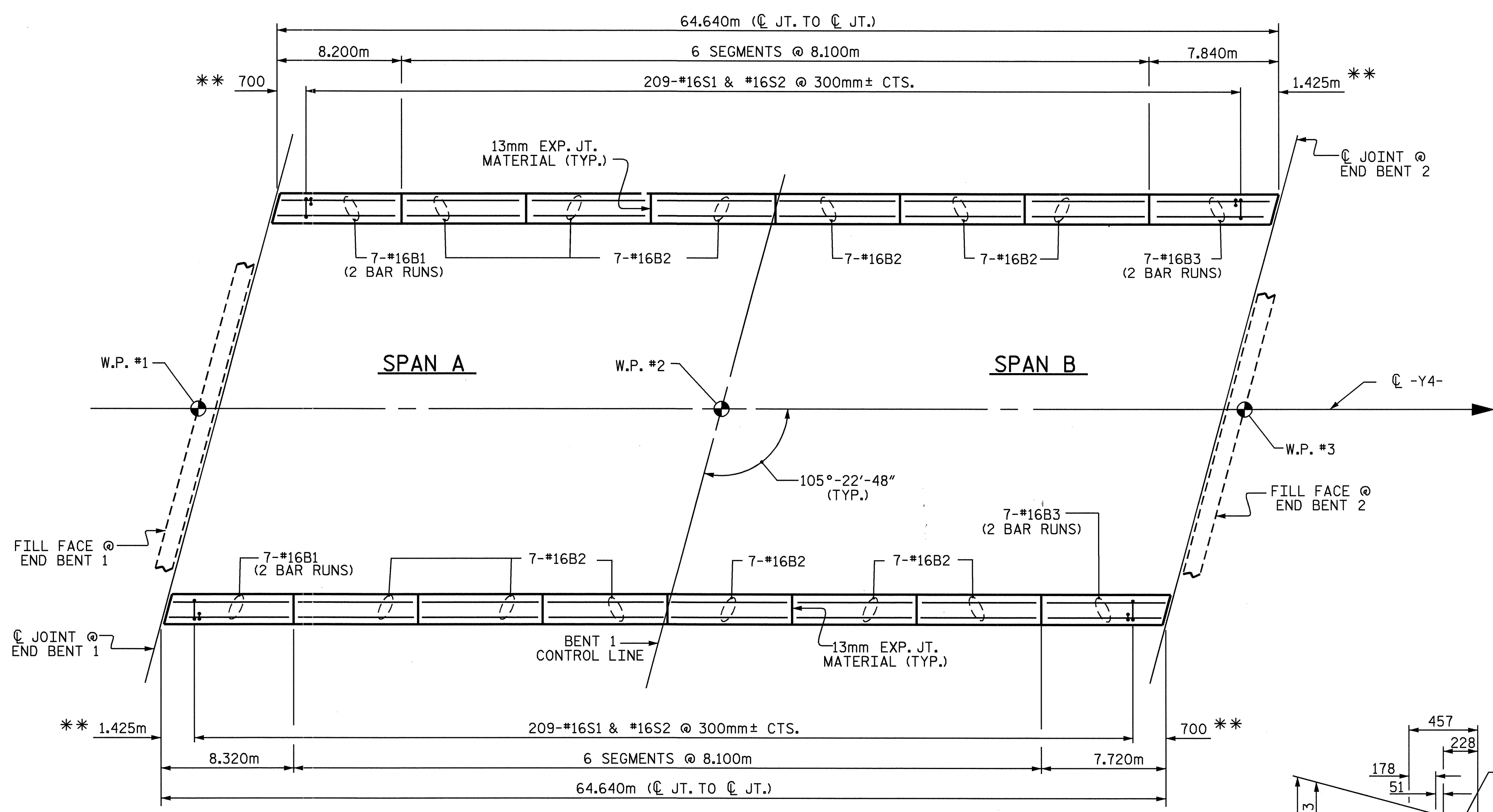

PLAN OF BARRIER RAIL

** SEE PLAN FOR END OF BARRIER RAIL FOR ADDITIONAL "S" BARS NOT SHOWN IN PLAN.

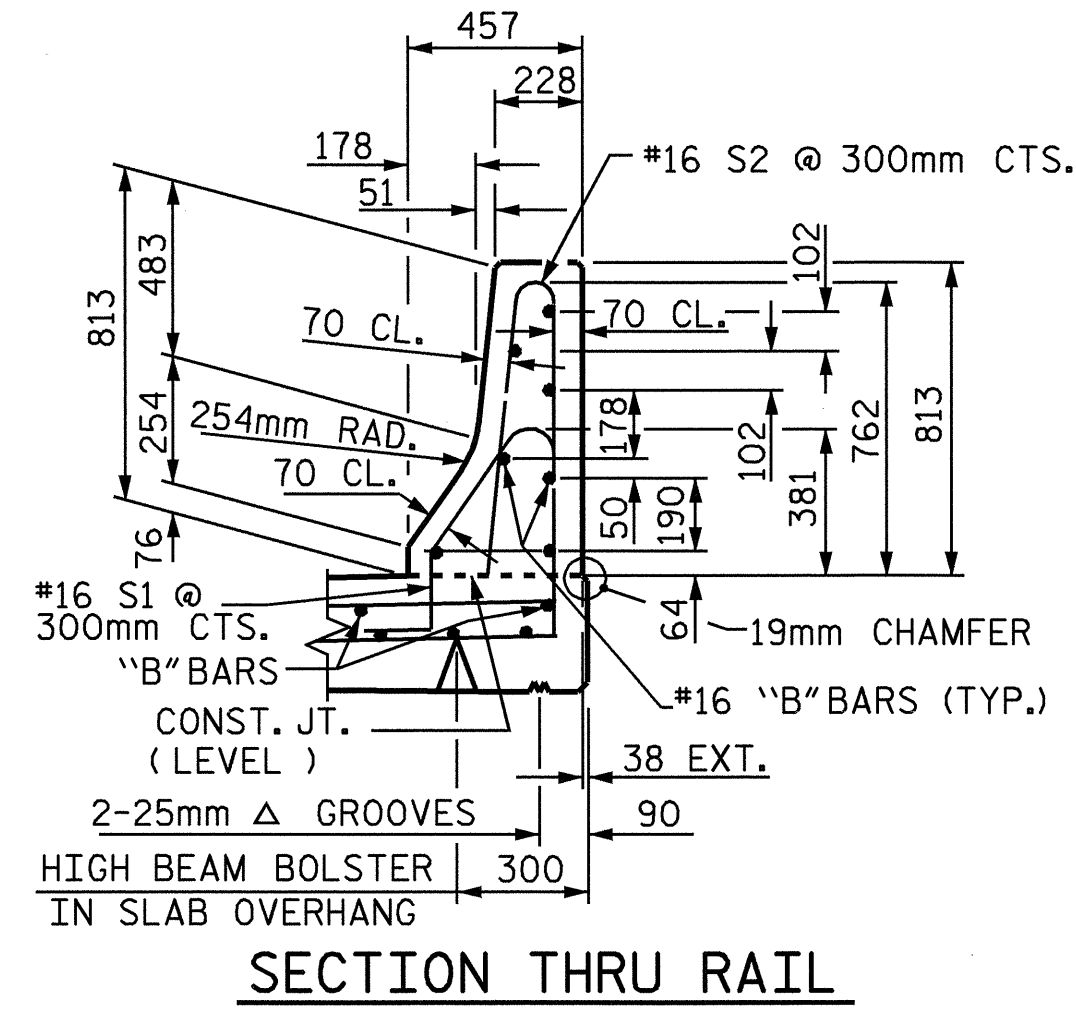

SECTION THRU RAIL

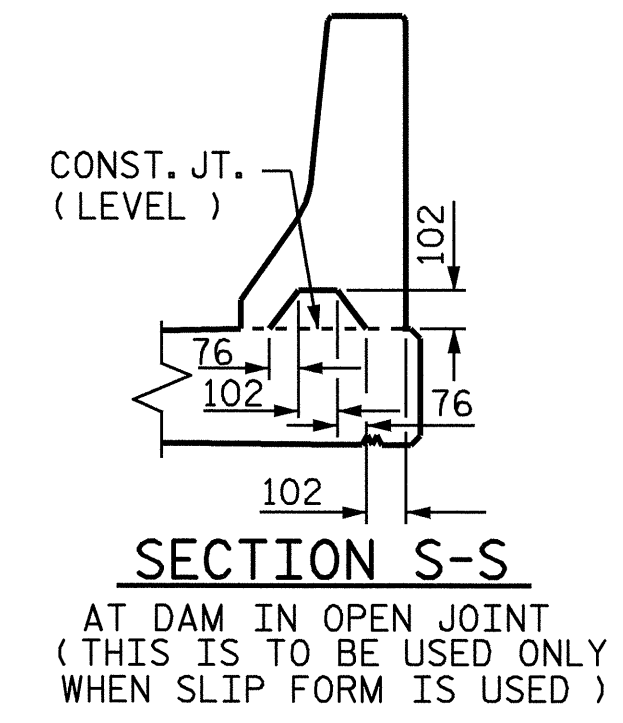

SECTION S-S

AT DAM IN OPEN JOINT (THIS IS TO BE USED ONLY WHEN SLIP FORM IS USED)

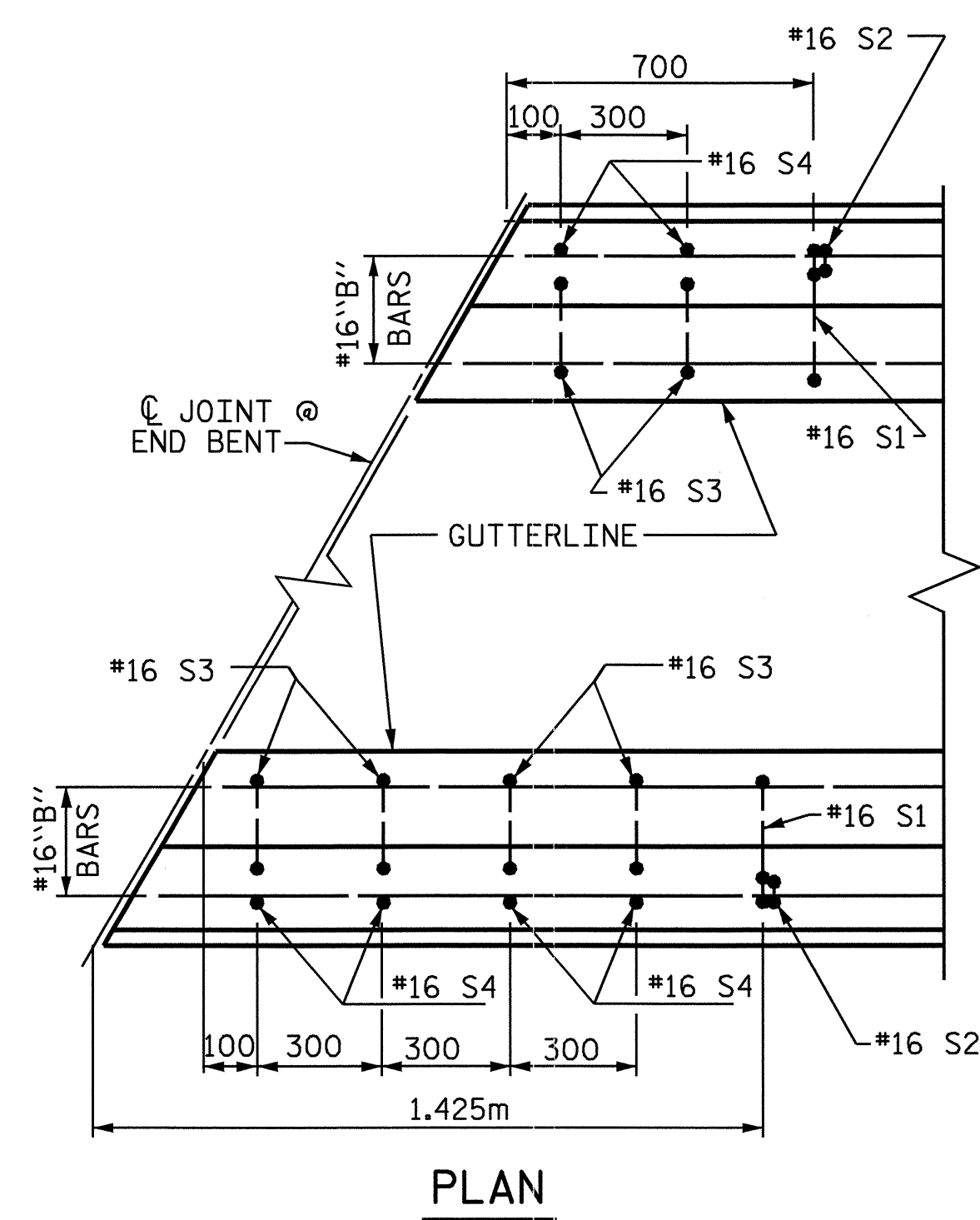

PLAN

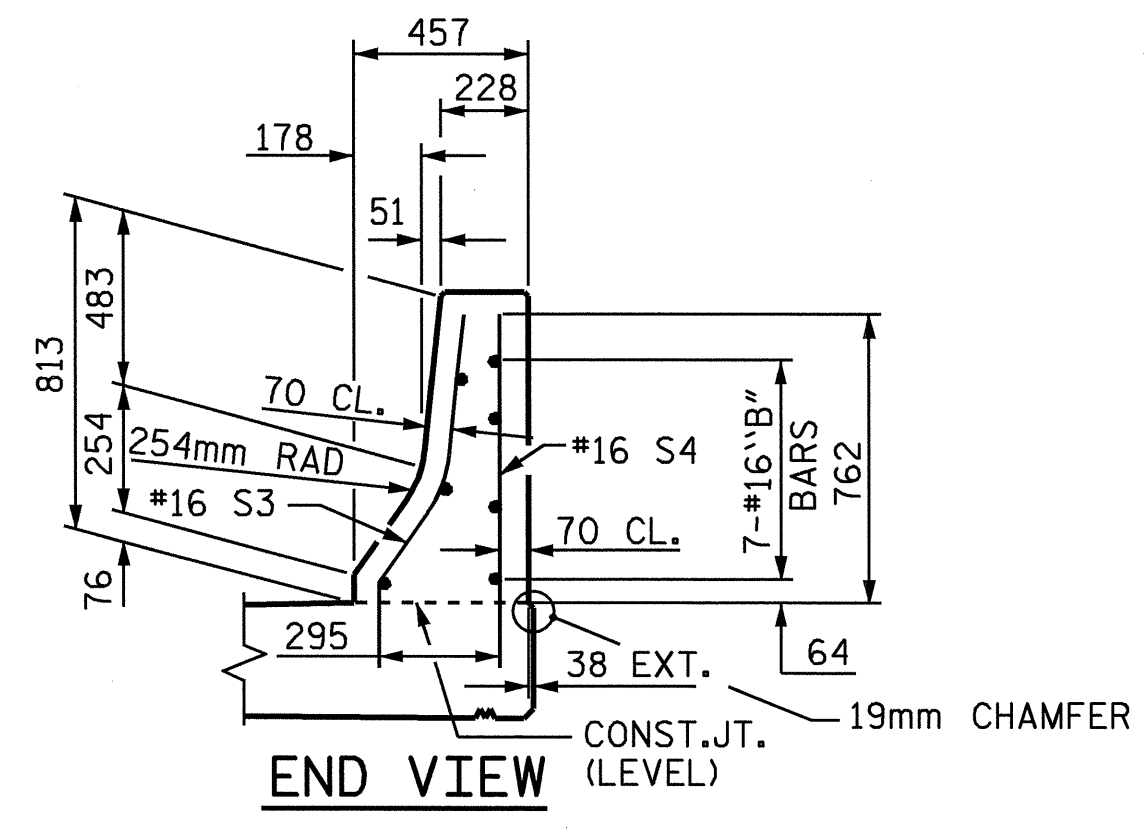

END VIEW

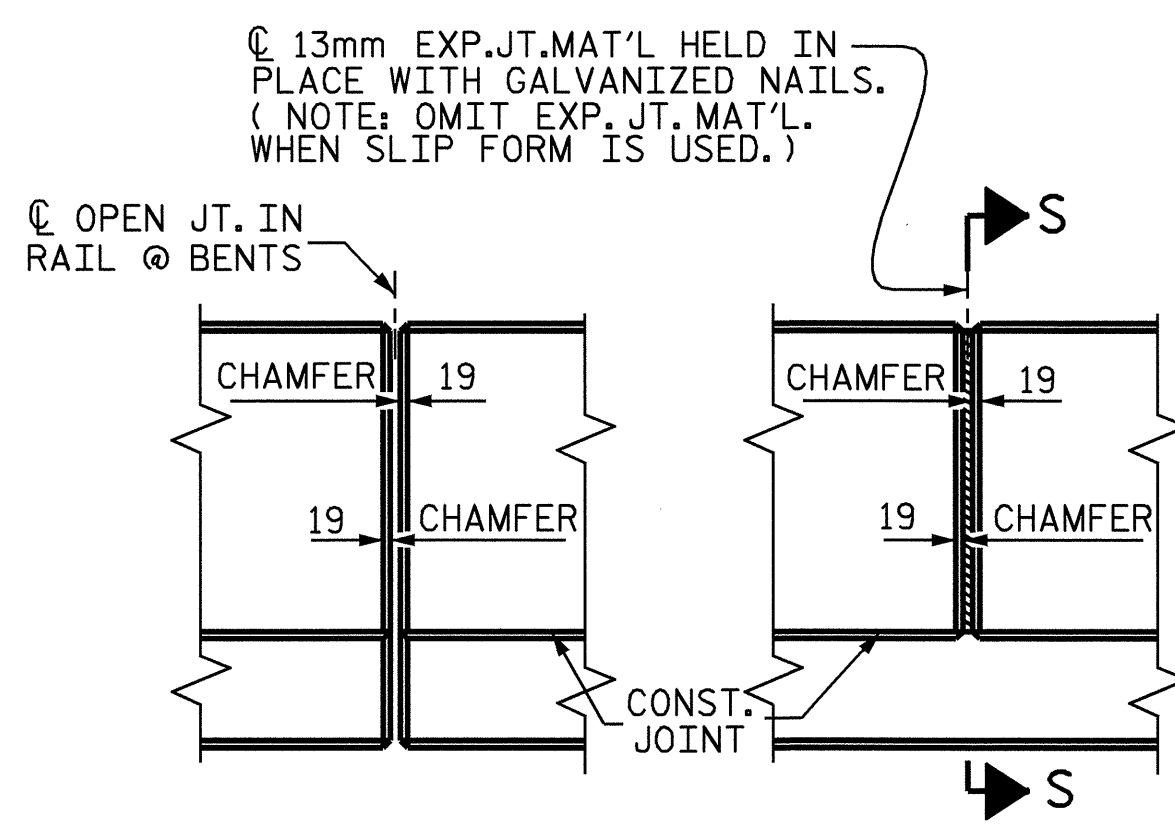

ELEVATION AT EXPANSION JOINTS

BARRIER RAIL DETAILS

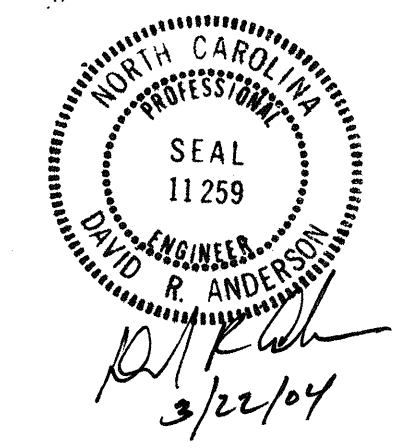

PROJECT NO. R-513C
ROBESON COUNTY
 STATION: 318+10.648 -L-

STATE OF NORTH CAROLINA
 DEPARTMENT OF TRANSPORTATION
 RALEIGH
**STANDARD
 CONCRETE
 BARRIER RAIL**

ASSEMBLED BY : N. Q. TRAN	DATE : JUN. 2001
CHECKED BY : T.A. WALTER	DATE : 10-24-02
DRAWN BY : ARB 5/87	REV. 5/16/97 EEM/RGW
CHECKED BY : SJD 9/87	REV. 7/17/98 RWW/LES
	REV. 8/16/99 RWW/LES

BARRIER RAIL - END OF RAIL DETAILS

REVISIONS						SHEET NO.
NO.	BY:	DATE:	NO.	BY:	DATE:	TOTAL SHEETS
1			3			5-295
2			4			312