

**GIRDER ELEVATION**

\*\* THE TOP OF THE GIRDER IN THE REGION OF LINK SLAB SHALL BE SMOOTH AND FREE OF SHEAR STUDS. NO WELDING OF THE FORMS OR FALSEWORK TO TOP FLANGE WILL BE PERMITTED IN THIS REGION.

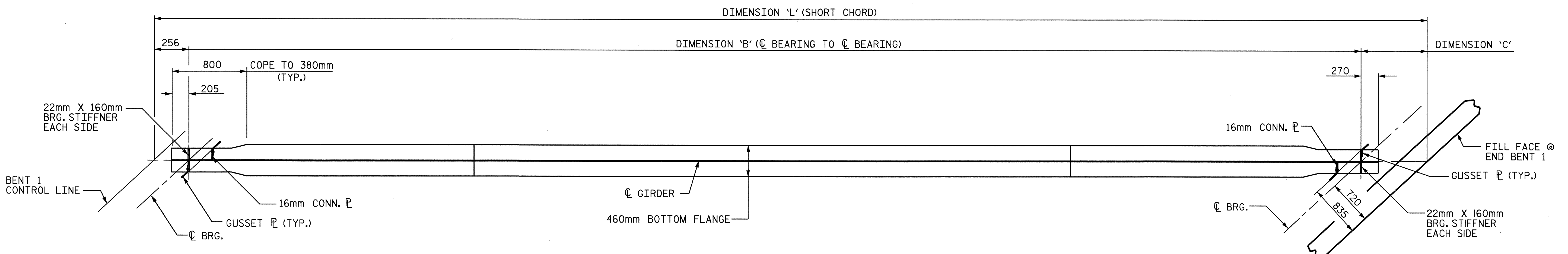

**BOTTOM FLANGE DETAIL**

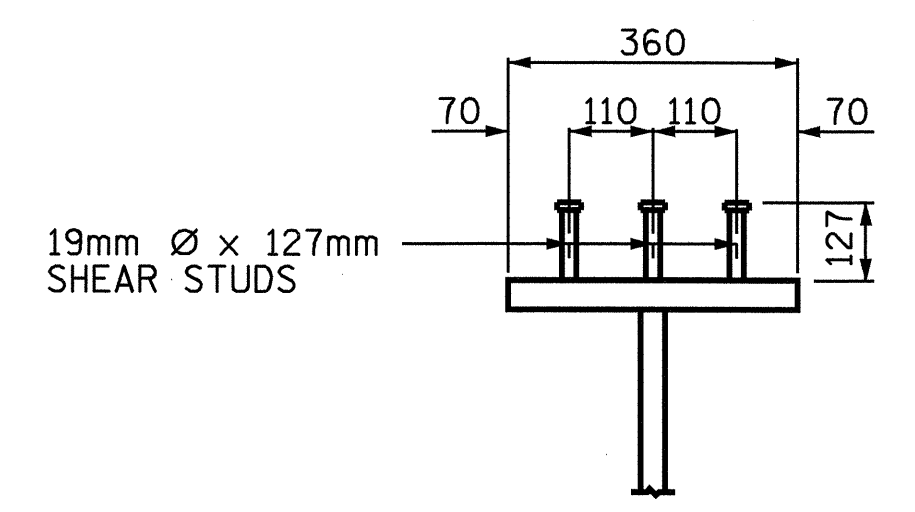

**SHEAR STUD DETAIL**

DIMENSIONS						
GRD. NO.	L	A	B	C	D	E
B1	38.821	38.022	37.547	1.019	21.962	0.052
B2	38.920	38.117	37.642	1.022	22.057	0.147
B3	39.019	38.214	37.739	1.024	22.154	0.244
B4	39.120	38.312	37.837	1.027	22.252	0.342

PROJECT NO. R-513BB  
ROBESON COUNTY  
 STATION: 209+17.263 -L-

SHEET 2 OF 3

STATE OF NORTH CAROLINA  
 DEPARTMENT OF TRANSPORTATION  
 RALEIGH  
**SUPERSTRUCTURE  
 STRUCTURAL STEEL  
 DETAILS  
 SPAN "B"**

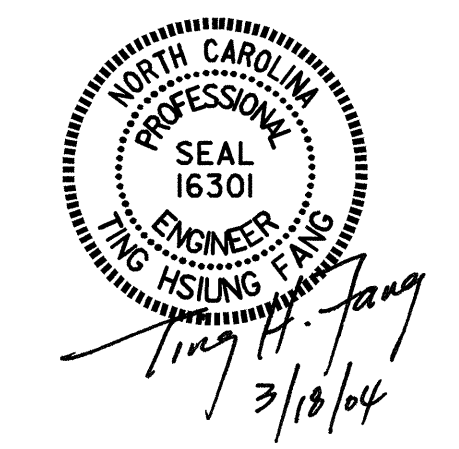

DRAWN BY: N. Q. TRAN DATE: 7/30/03  
 CHECKED BY: M. A. ALLEN DATE: 2-04

REVISIONS					SHEET NO.
NO.	BY:	DATE:	NO.	DATE:	S-42
1			3		TOTAL SHEETS
2			4		312