

NOTES

CONCRETE DESIGN DATA : f'c = 34.5 MPa; fc = 13.8 MPa

IMPACT IN HANDLING = 50%

THE TRANSFER OF LOAD FROM THE ANCHORAGES TO THE PILE SHALL BE DONE WHEN THE CONCRETE HAS REACHED A COMPRESSIVE STRENGTH OF NOT LESS THAN 24.1 MPa.

IN DRIVING PILES, A METHOD APPROVED BY THE ENGINEER SHALL BE USED, WHEREBY THE HEAD OF THE PILE IS NOT DAMAGED.

PROPOSED DEVICES FOR LIFTING PILES, RECESS DETAILS, AND PATCHING MATERIAL SHALL BE DETAILED IN SHOP DRAWINGS. AFTER ATTACHMENTS HAVE BEEN REMOVED, OPENINGS SHALL BE REPAIRED SUCH THAT THE APPEARANCE OF THE PILE IS UNIFORM.

WHERE CAST - IN - PLACE LIFTING DEVICES ARE NOT USED, PICK-UP POINTS TO BE INDICATED WITH A BLACK MARK 50mm WIDE.

ALL PRESTRESSING STRANDS SHALL BE 7-WIRE LOW RELAXATION GRADE 270 STRANDS AND SHALL CONFORM TO AASHTO M203M EXCEPT FOR SAMPLING REQUIREMENTS WHICH SHALL BE IN ACCORDANCE WITH STANDARD SPECIFICATIONS.

THE CONTRACTOR MAY USE EITHER OF THE FOLLOWING STRAND CONFIGURATIONS:

SIZE	GRADE	NUMBER OF STRANDS	AREA mm ²	ULTIMATE STRENGTH KN	APPLIED PRESTRESS FORCE KN
12.70	270	4	98.71	183.7 PER STRAND	137.8 PER STRAND
12.70	270	5	98.71	183.7 PER STRAND	137.8 PER STRAND

THE SLIP-FORM METHOD OF CASTING PILES WILL NOT BE PERMITTED.

IF STRAND STRESS IS RELIEVED BY BURNING, THE STRANDS SHALL BE BURNED IN PAIRS, EXCEPT WHERE 5 STRANDS ARE USED THE LAST STRAND MAY BE BURNED SINGLY, ACCORDING TO BURNING PATTERNS SHOWN. NOT MORE THAN 4 STRANDS MAY BE BURNED AT ANY ONE SECTION BEFORE THE SAME STRANDS ARE BURNED AT BOTH ENDS OF THE BED AND BETWEEN EACH PAIR OF PILES IN THE BED.

BUILD-UPS SHALL BE 'CLASS A' CONCRETE WITH 20% ADDITIONAL CEMENT. NO DRIVING OF THE BUILT-UP PILE WILL BE PERMITTED UNTIL THE CONCRETE HAS REACHED A COMPRESSIVE STRENGTH OF 20.7 MPa AND UNTIL A PERIOD OF SEVEN DAYS HAS ELAPSED SINCE CASTING OF THE BUILD-UP.

ALL CORNERS TO BE CHAMFERED 19mm.

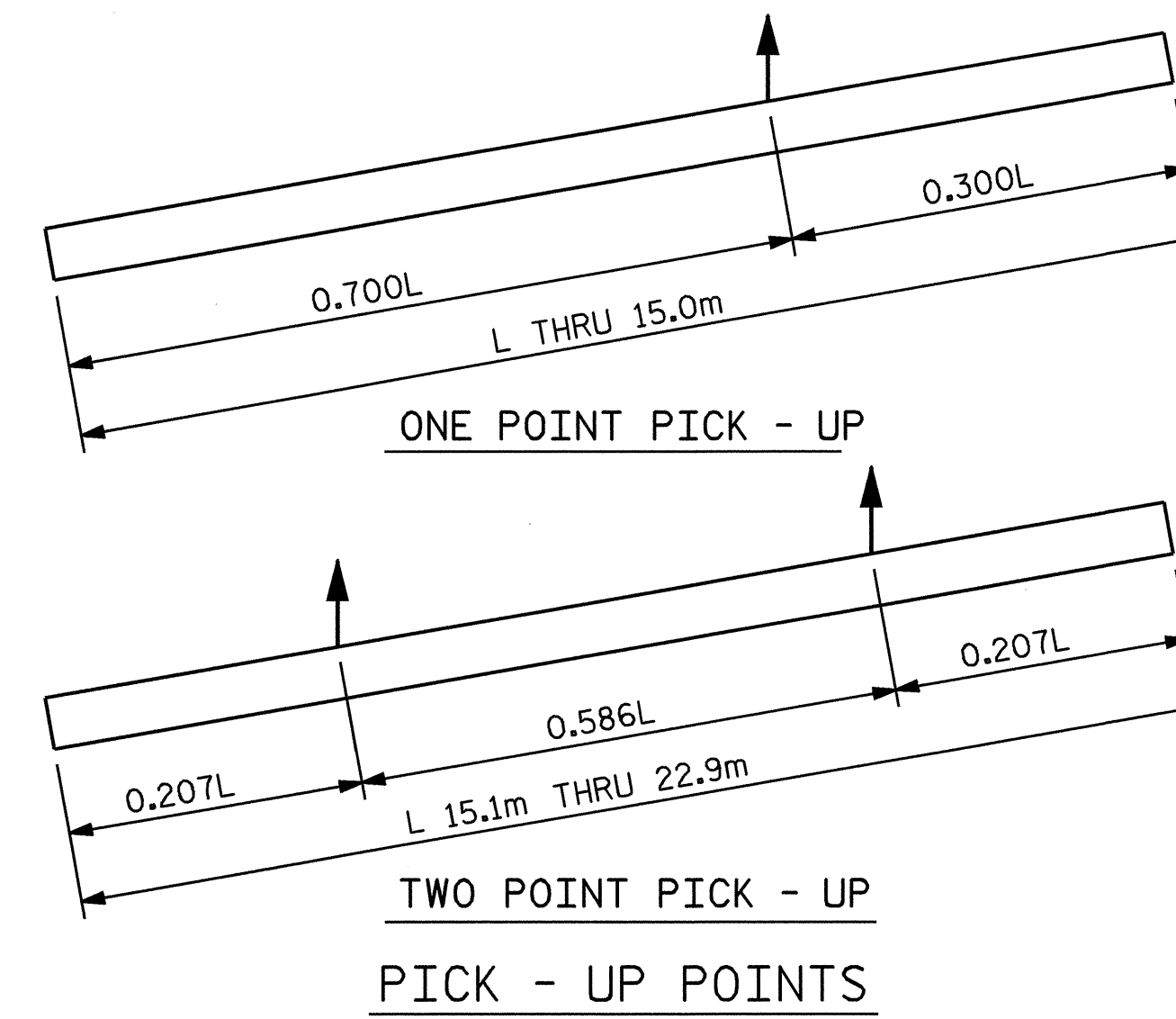

QUANTITIES FOR ONE 305mm PRESTRESSED PILE

LENGTH m	CONCRETE m ³	PILE WT. kg	ONE PICK-UP POINT		TWO PICK-UP POINT	
			0.300L m	0.700L m	0.207L m	0.586L m
7.5	0.70	1680	2.25	5.25		
9.0	0.84	2020	2.70	6.30		
10.5	0.98	2350	3.15	7.35		
12.0	1.12	2690	3.60	8.40		
13.5	1.26	3030	4.05	9.45		
15.0	1.40	3360	4.50	10.50		
16.5	1.53	3680			3.42	9.67
18.0	1.67	4010			3.73	10.55
19.5	1.81	4350			4.04	11.43
21.0	1.95	4690			4.35	12.31
22.5	2.09	5020			4.66	13.19

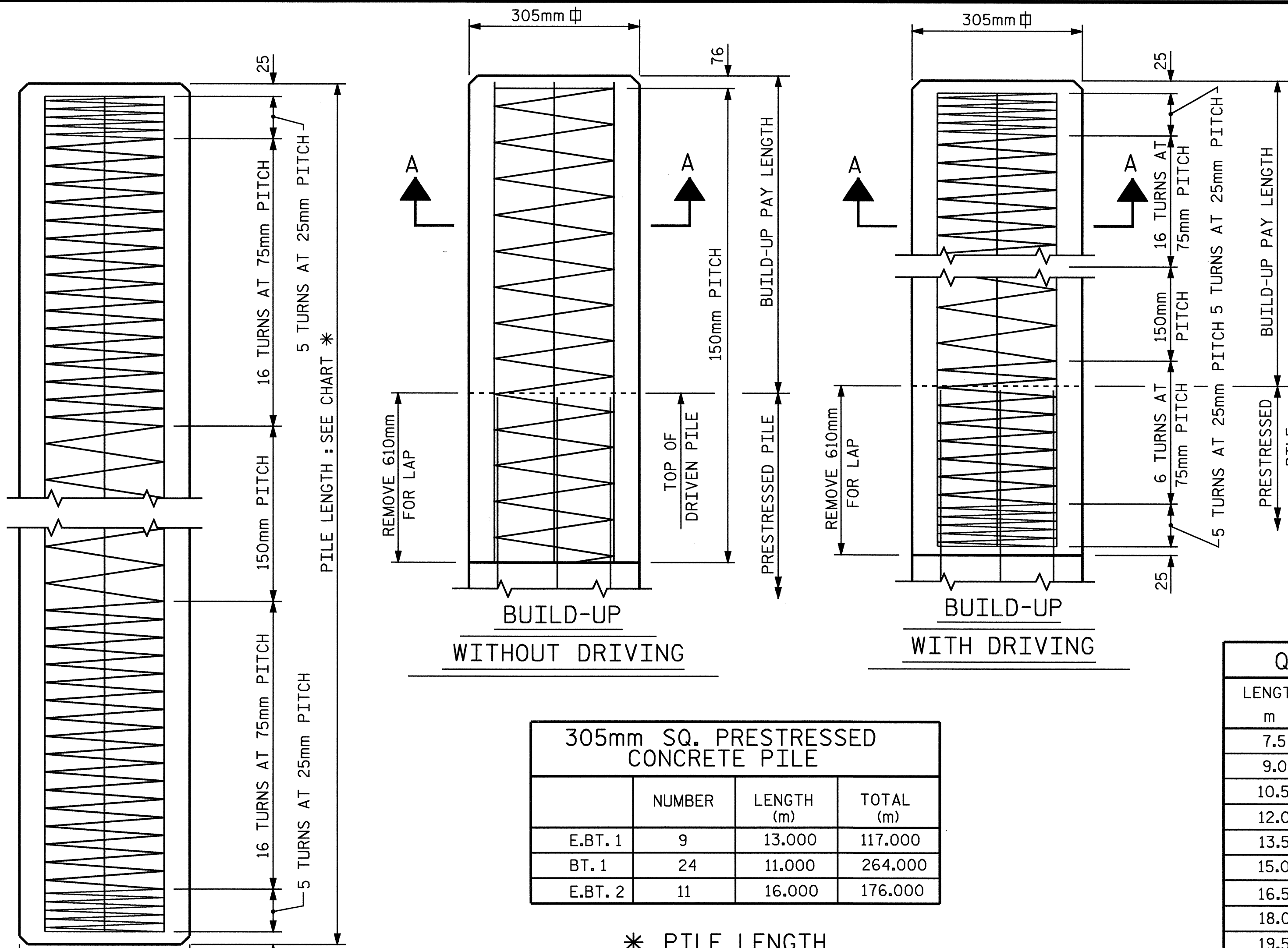

305mm SQ. PRESTRESSED CONCRETE PILE

	NUMBER	LENGTH (m)	TOTAL (m)
E.BT. 1	9	13.000	117.000
BT. 1	24	11.000	264.000
E.BT. 2	11	16.000	176.000

* PILE LENGTH

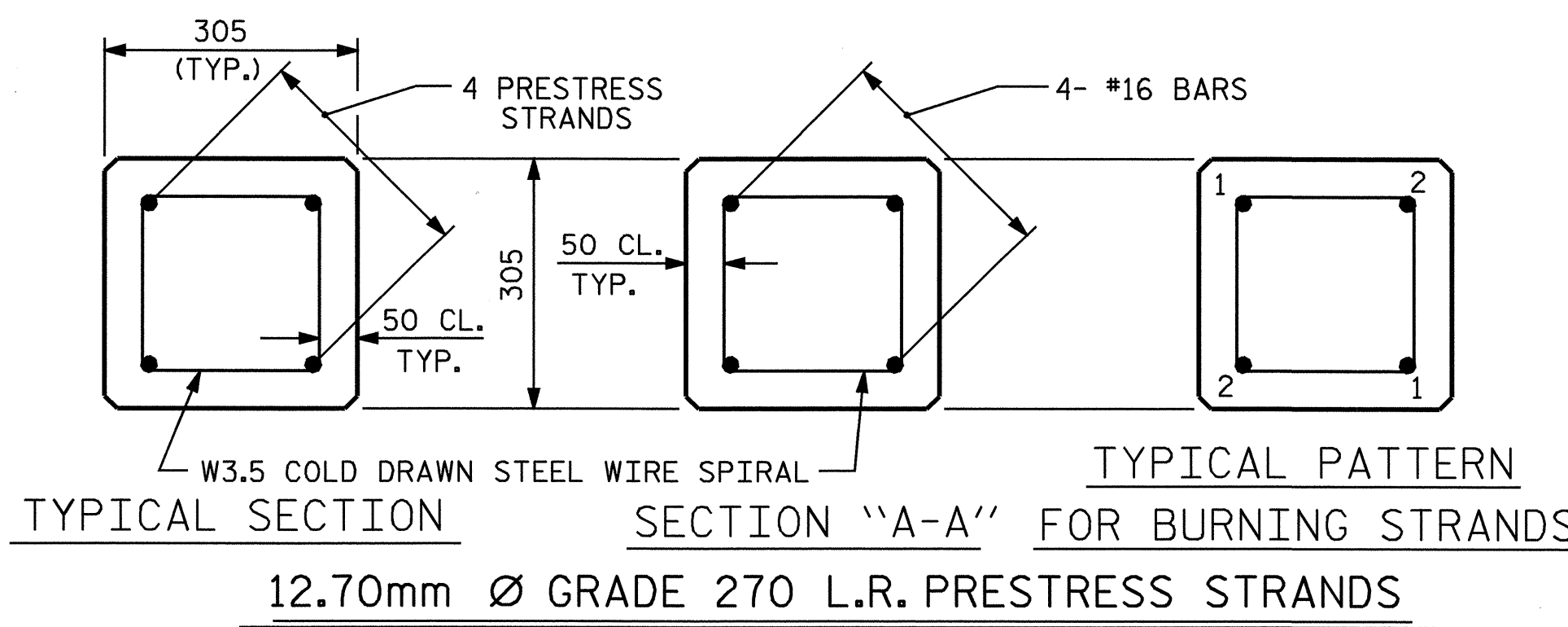
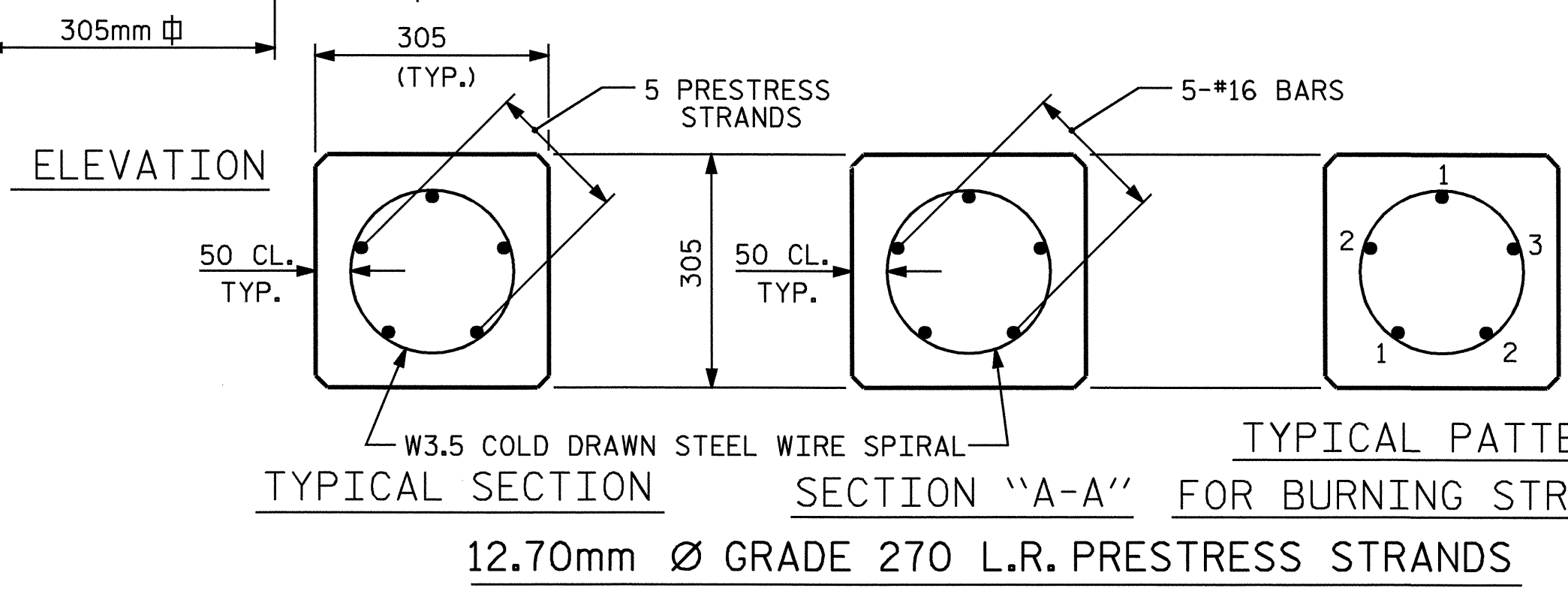

PROJECT NO. R-513C
ROBESON COUNTY
 STATION: 271+08.001 -L-

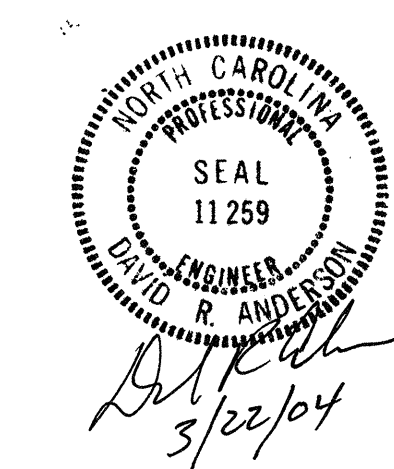

STATE OF NORTH CAROLINA
 DEPARTMENT OF TRANSPORTATION
 RALEIGH

SUBSTRUCTURE
305mm SQ. PRESTRESSED
CONCRETE PILE

REVISIONS						SHEET NO.
NO.	BY:	DATE:	NO.	BY:	DATE:	TOTAL SHEETS
1			3			5-123
2			4			312

ASSEMBLED BY : S. M. RASHIDI	DATE : 2/25/04
CHECKED BY : N. TRAN	DATE : 2/25/04
DRAWN BY : FCJ 7/88	REV. 5/16/97 EEM/RGW
CHECKED BY : CRK 3/89	REV. 7/17/98 RWW/LES
	REV. 8/16/99 RWW/LES