

AREA III EXISTING US 74

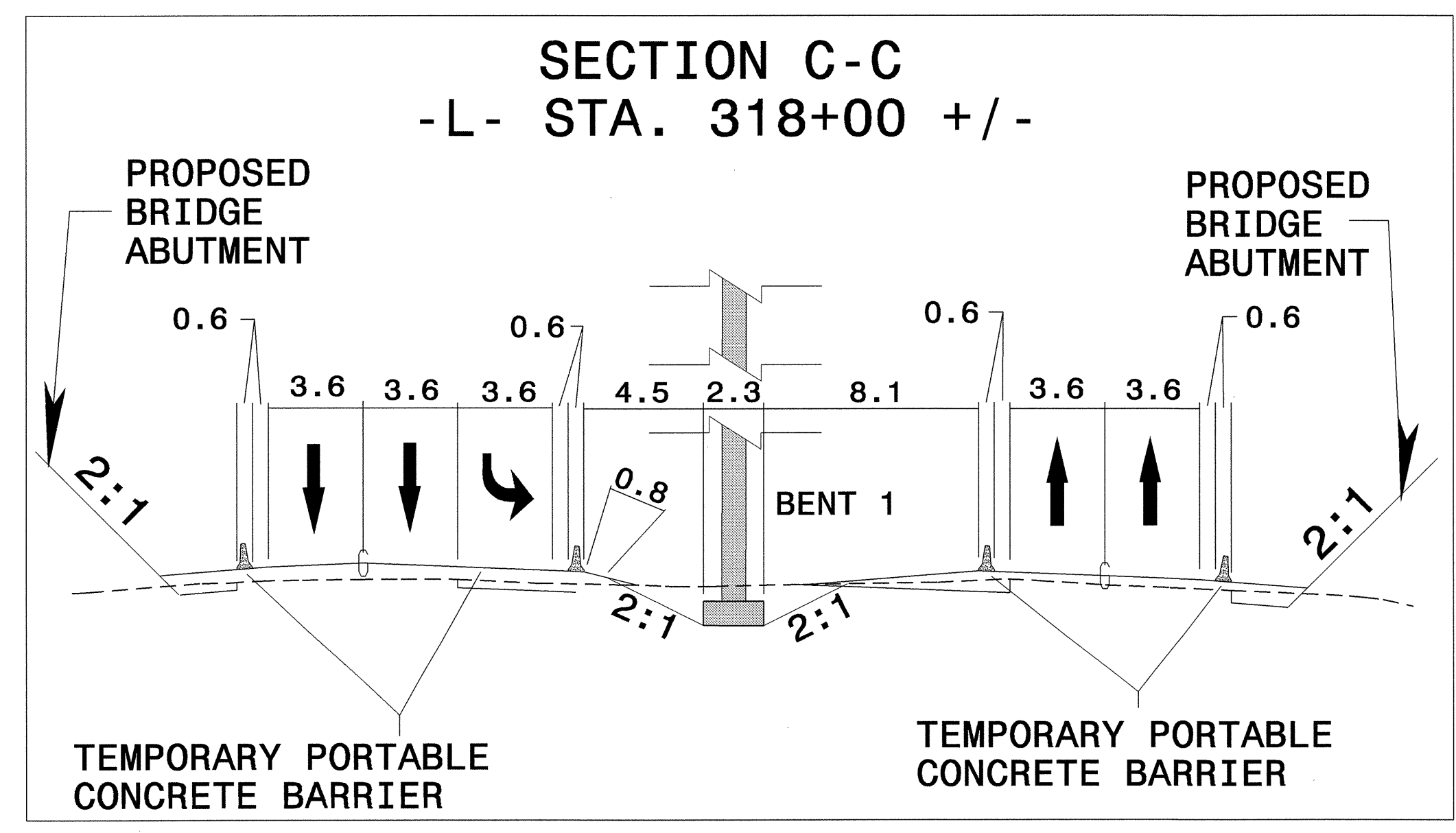

PROJ. REFERENCE NO. R-0513BB/C	SHEET NO. TCP-30B
-----------------------------------	----------------------

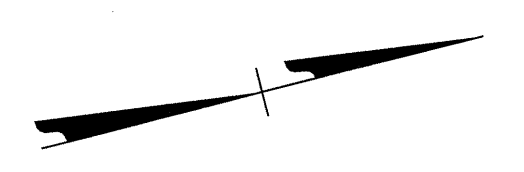
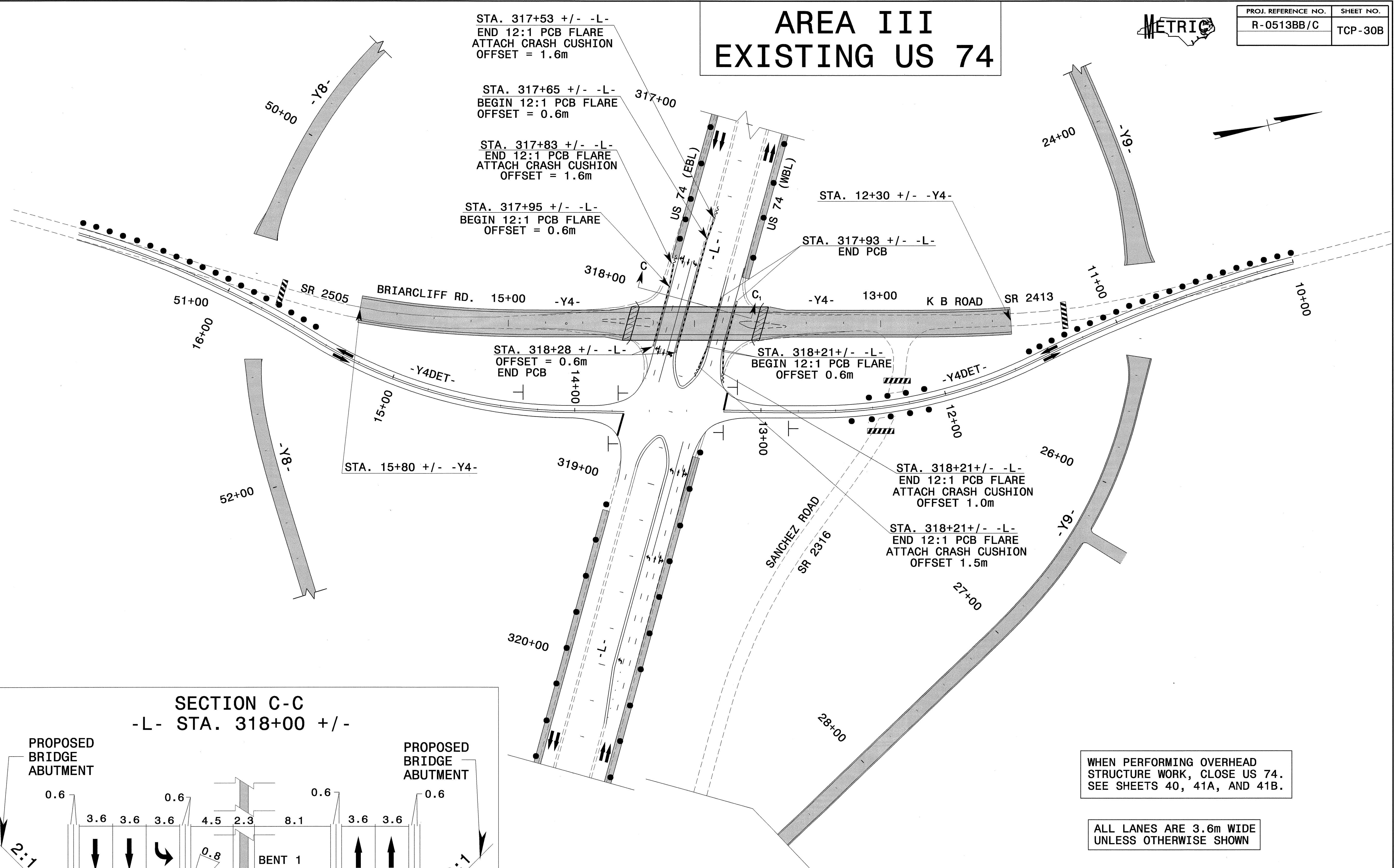

WHEN PERFORMING OVERHEAD
STRUCTURE WORK, CLOSE US 74.
SEE SHEETS 40, 41A, AND 41B.

ALL LANES ARE 3.6m WIDE
UNLESS OTHERWISE SHOWN

24-JUN-2004 16:34
 F:\TCP\FINAL TCP\SR513C.TC.TCP030B.dgn
 msteelman AT TETC21231

APPROVED: *John S. Kite Jr.* DATE: 6/25/04

SEAL

PHASE I -L- / -Y4- CONSTRUCTION

SCALE: 1:1000		REVISIONS
DATE: 2-04		
DWG. BY: MHS		
DESIGN BY: MHS		
REVIEWED BY: CLM		

CADD FILE: R513C TC Y4 SH10B.DGN