

TYPICAL SECTION

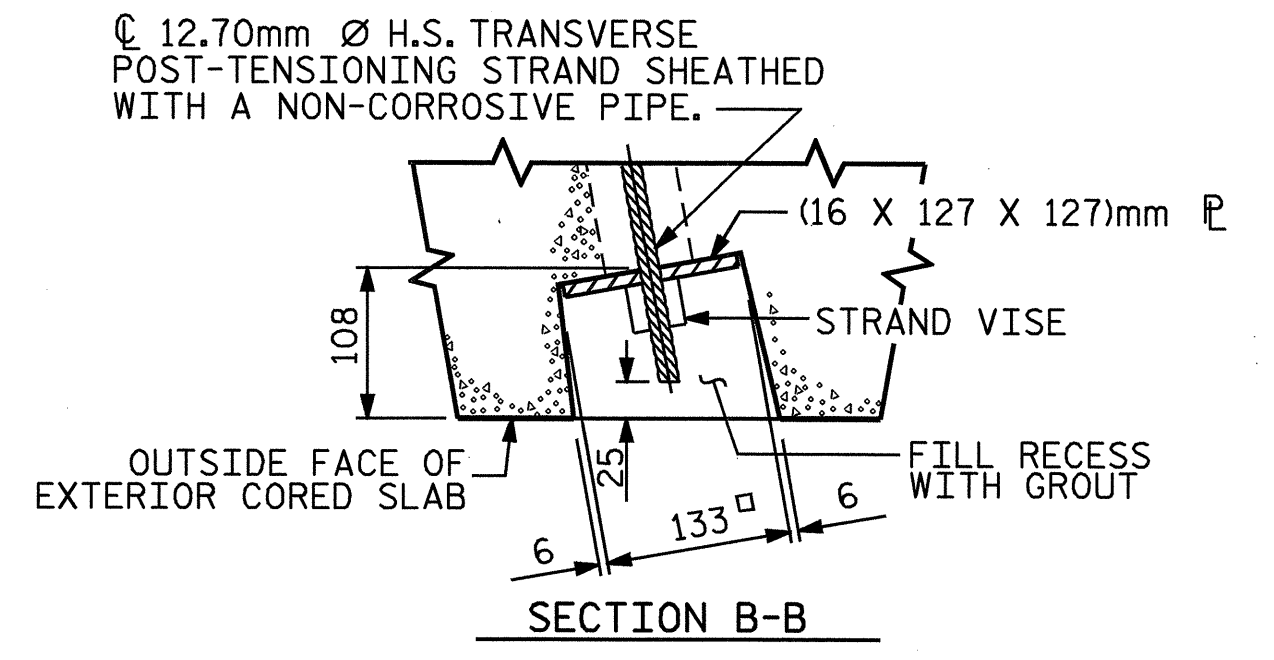

GROUPED RECESS AT END OF POST-TENSIONED STRAND CORED SLABS

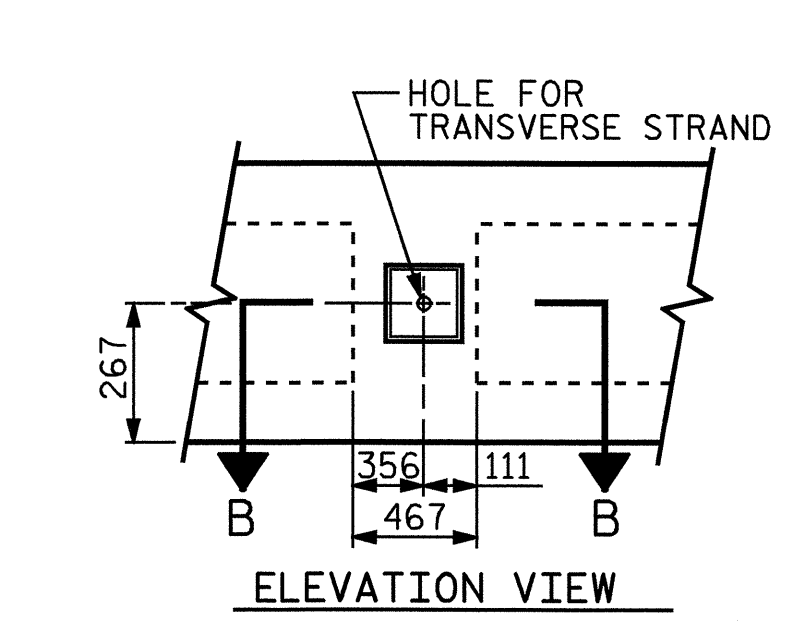
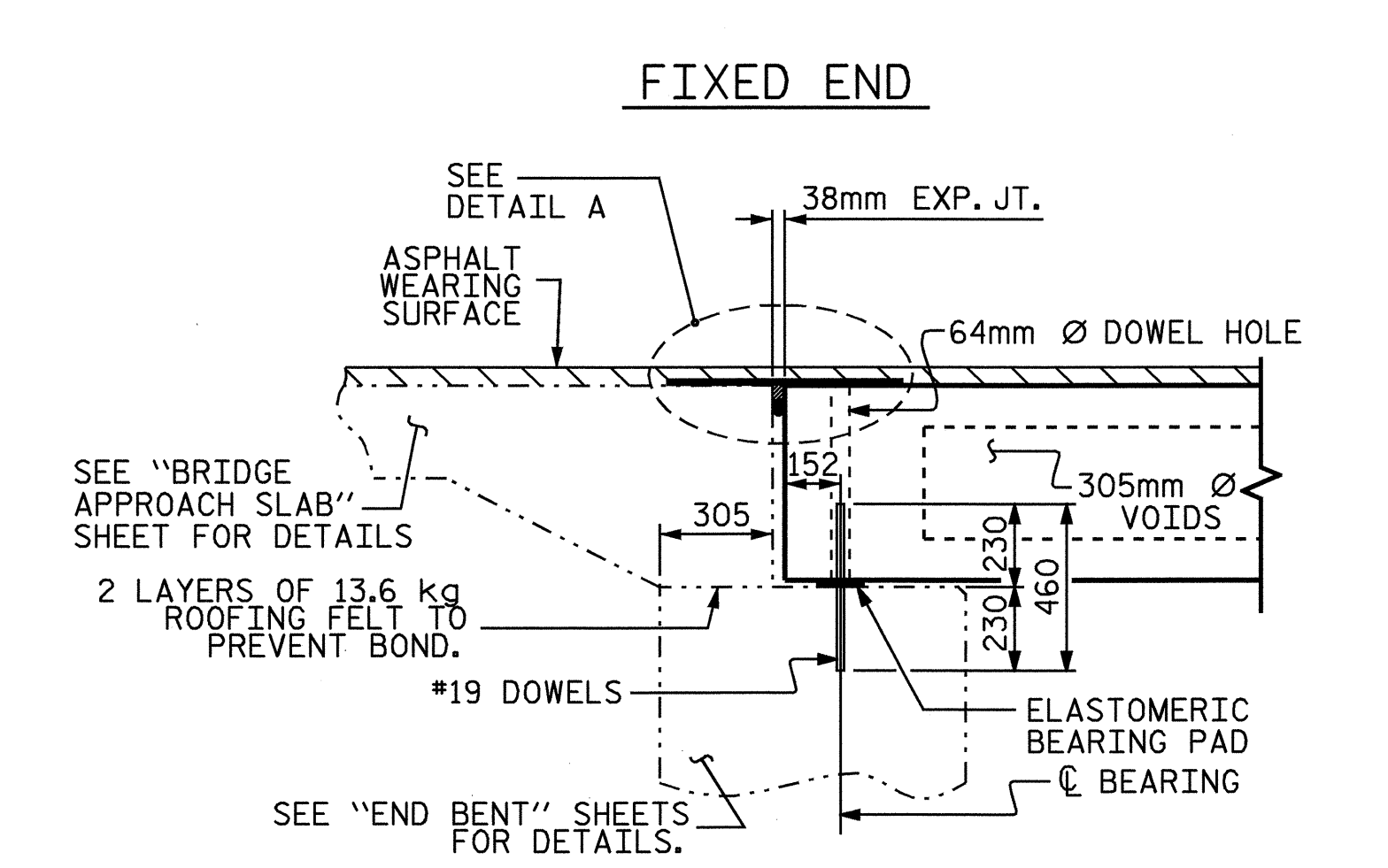

SECTION AT END BENT

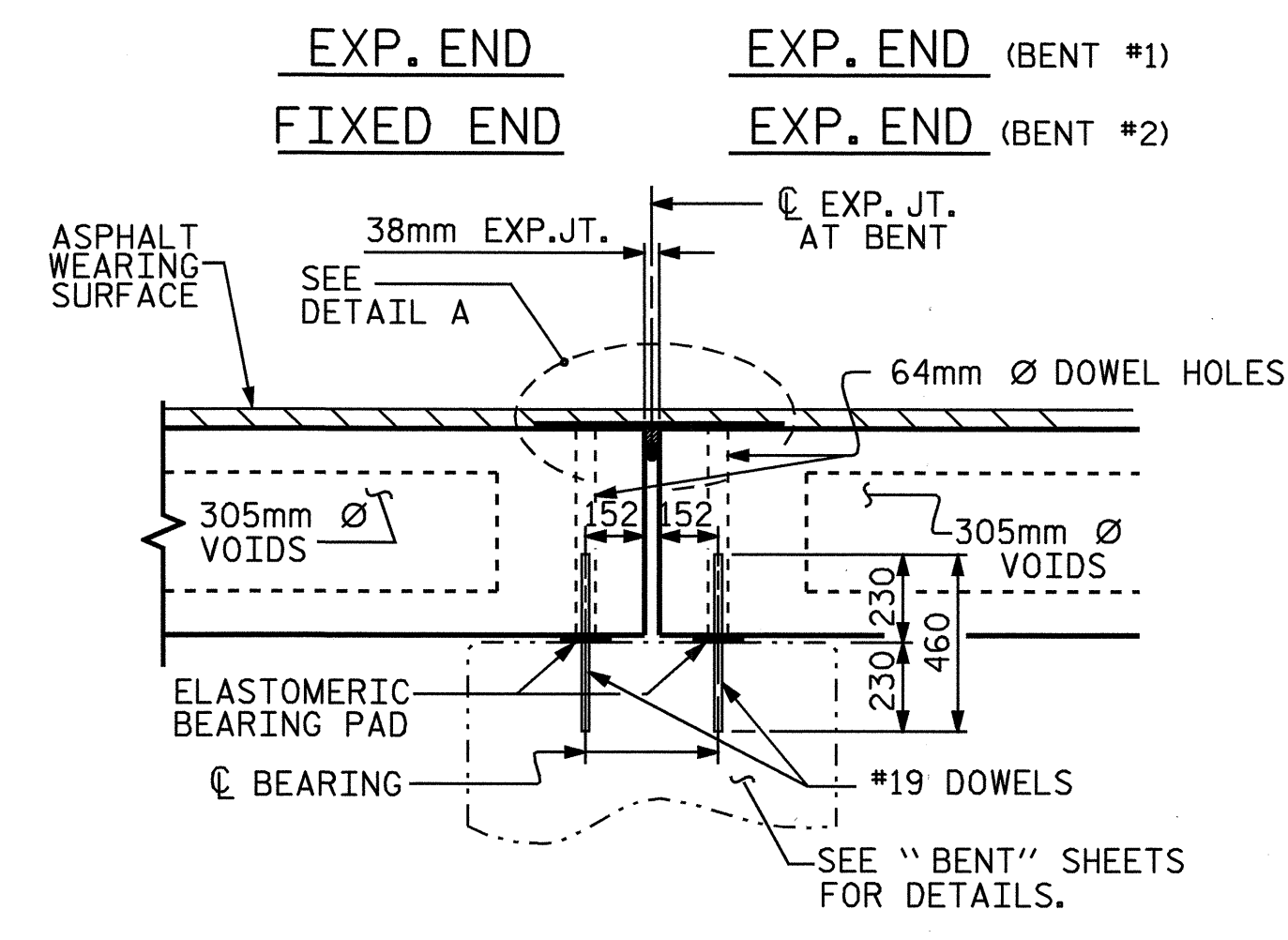

SECTION AT BENT

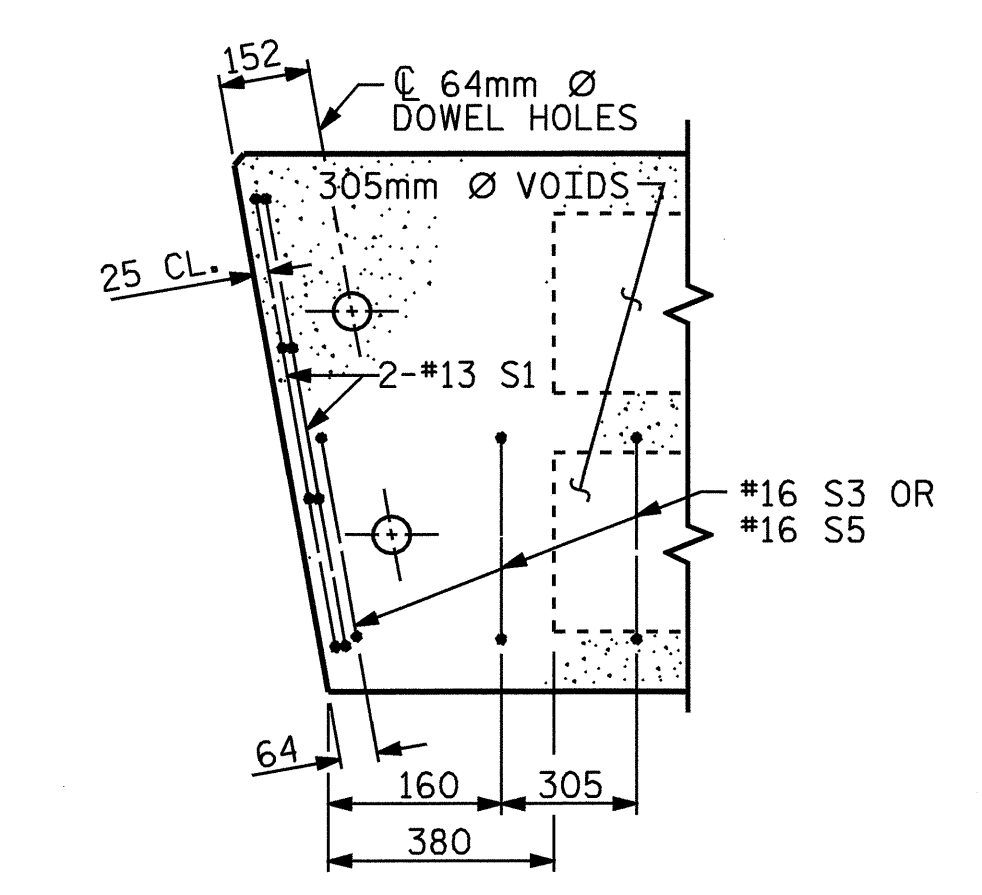

PART PLAN-EXTERIOR SECTION  
NOTE: EXTERIOR SECTION SHOWN-INTERIOR SECTION SIMILAR EXCEPT OMIT S3 BARS.

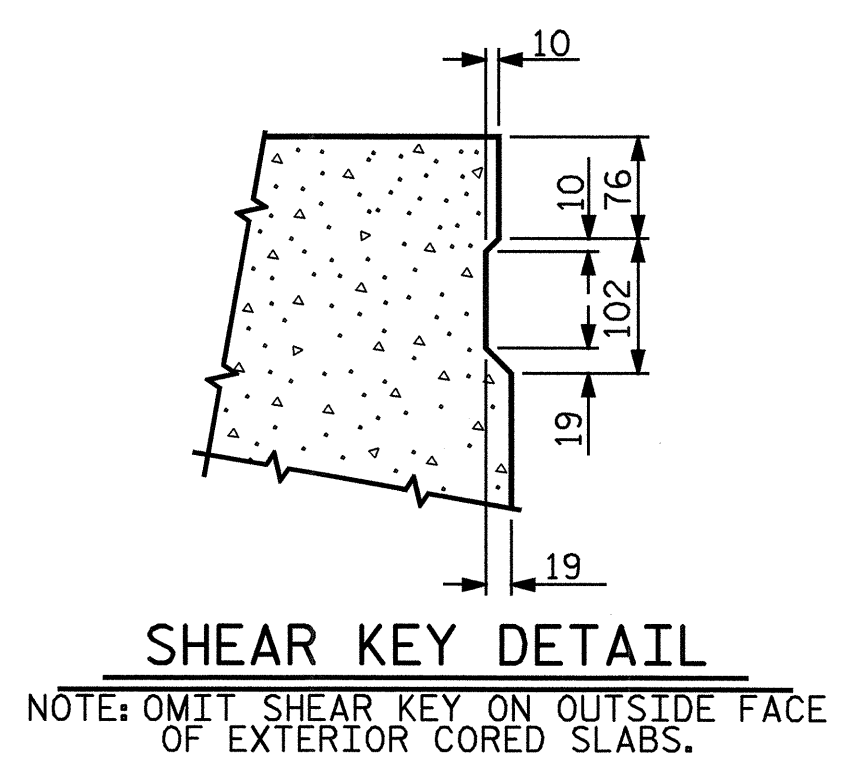

SHEAR KEY DETAIL  
NOTE: OMIT SHEAR KEY ON OUTSIDE FACE OF EXTERIOR CORED SLABS.

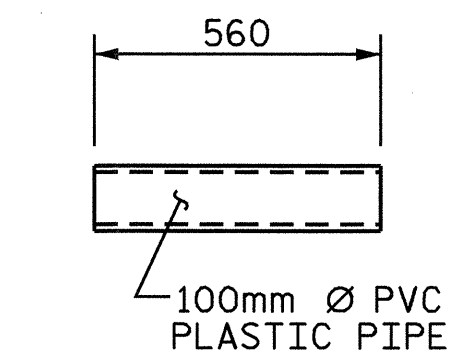

DRAIN DETAIL  
(24 REQUIRED)

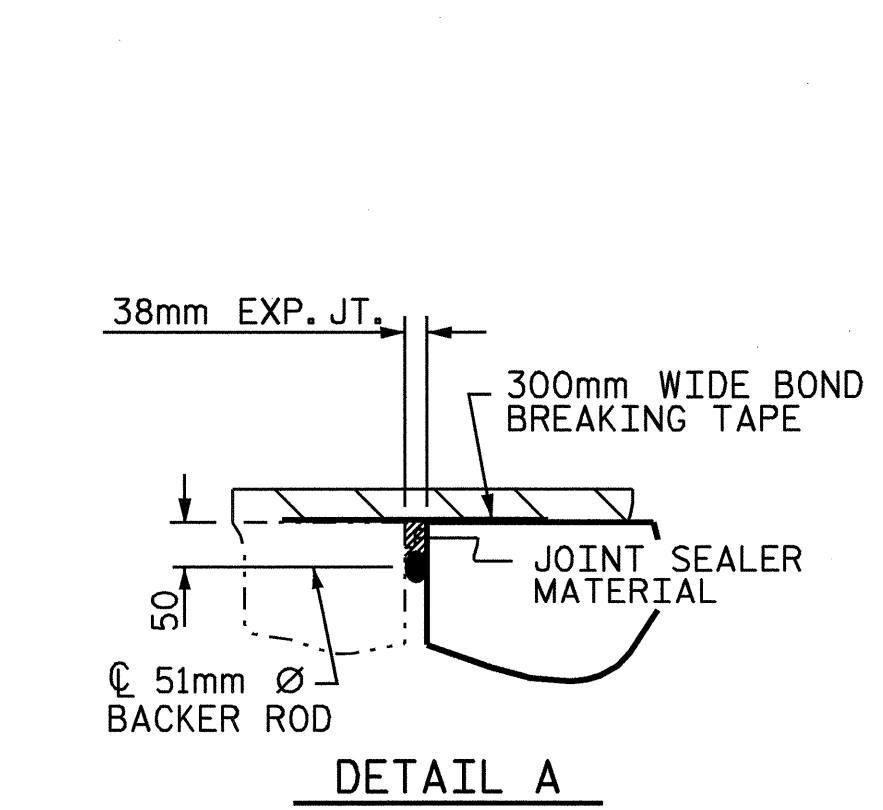

DETAIL A

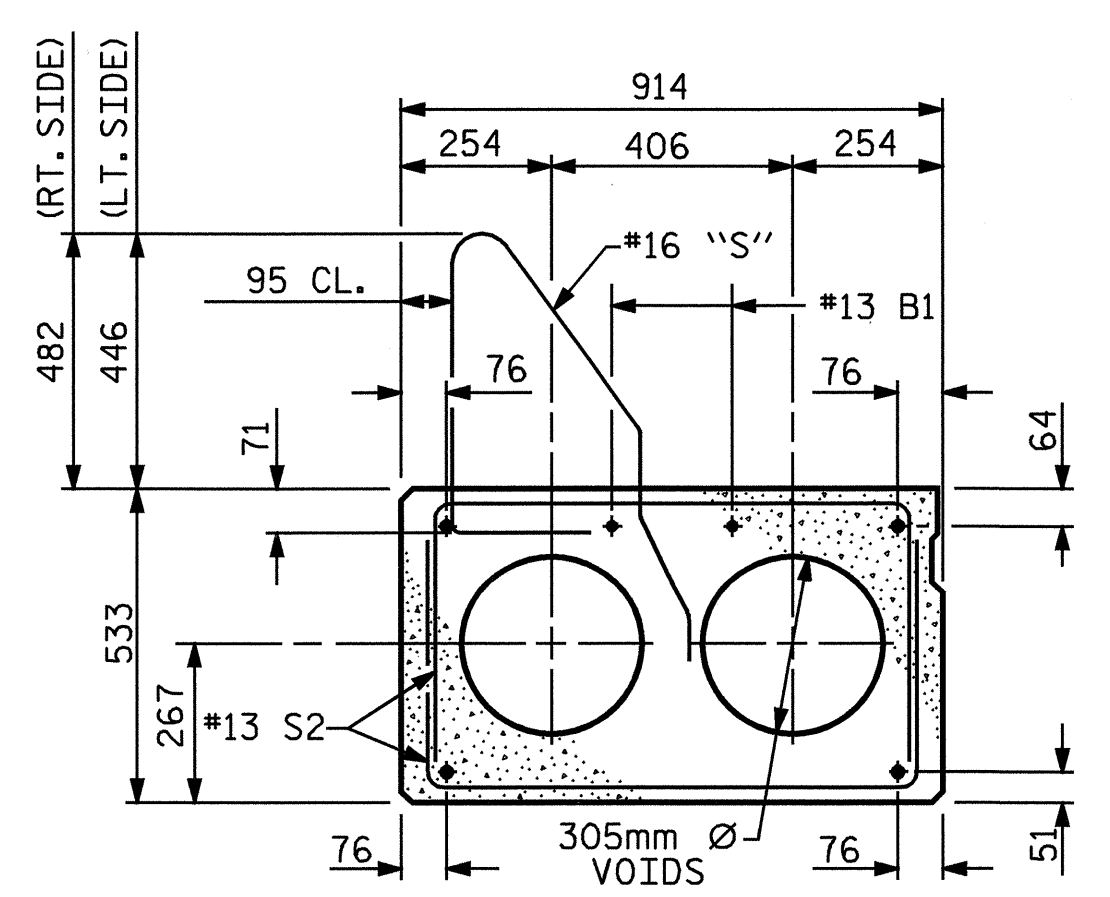

EXTERIOR SLAB SECTION

(FOR PRESTRESSED STRAND LAYOUT, SEE INTERIOR SLAB SECTION.)

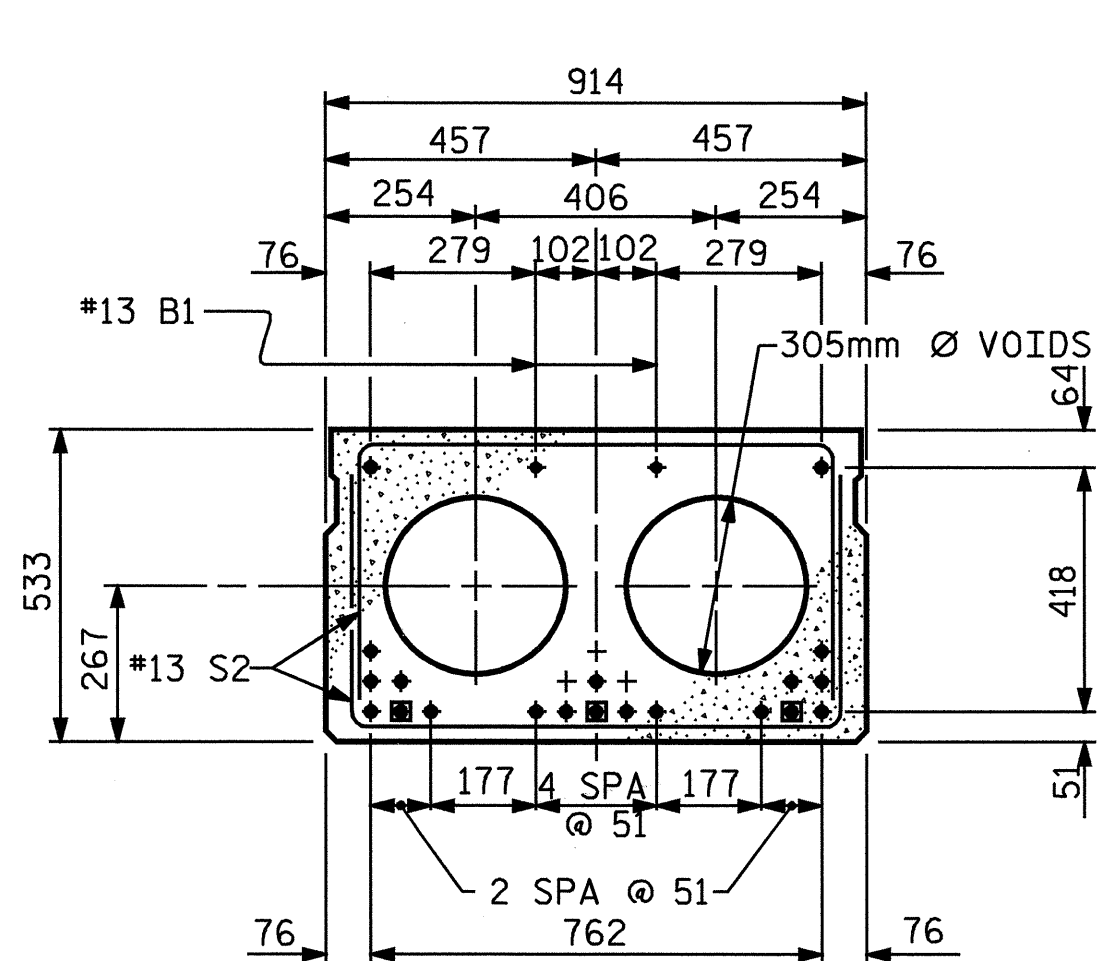

INTERIOR SLAB SECTION

BOND SHALL BE BROKEN ON THESE STRANDS FOR A DISTANCE OF FOUR FEET FROM END OF CORED SLAB UNIT. SEE STANDARD SPECIFICATIONS ARTICLE 1078-7.

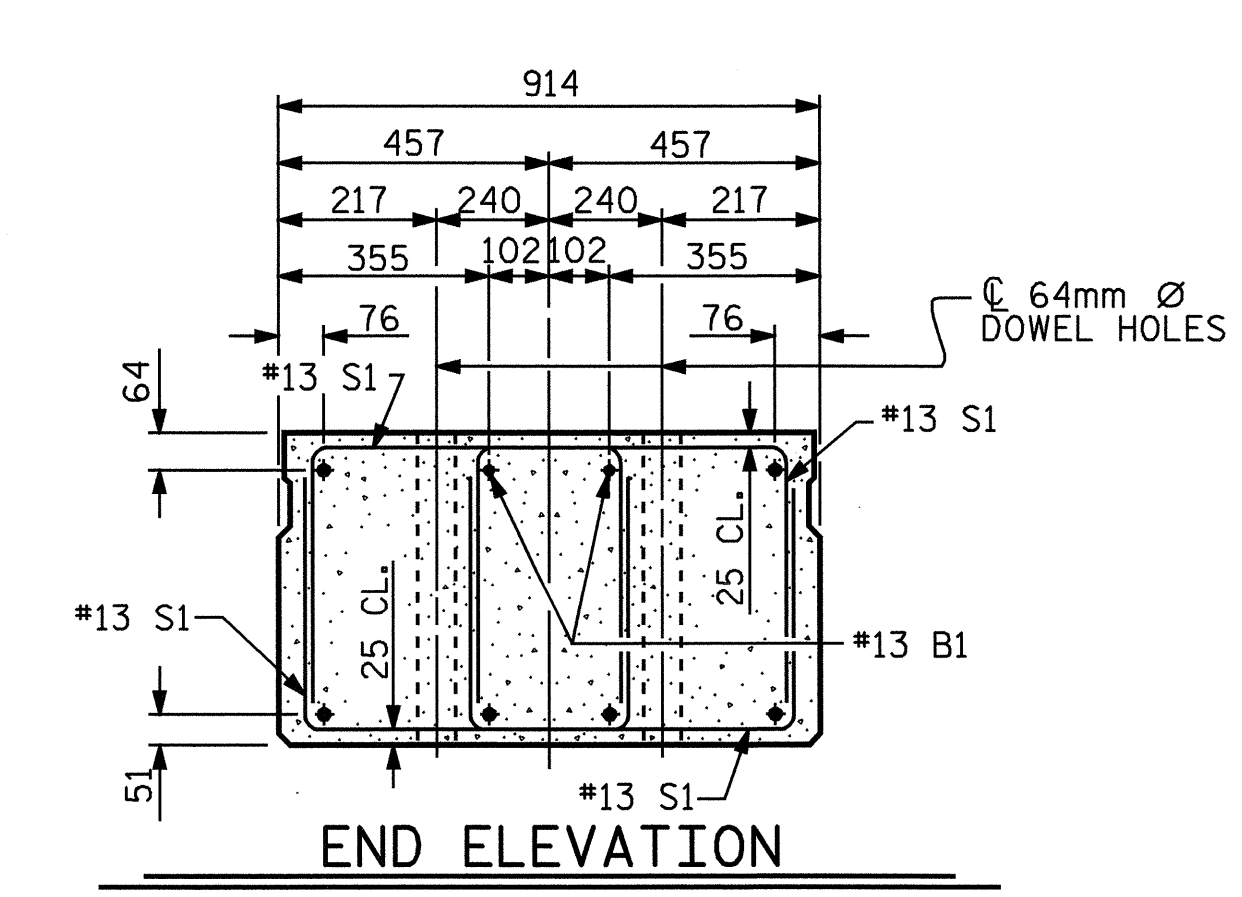

END ELEVATION

SHOWING PLACEMENT OF DOUBLE STIRRUPS AND LOCATION OF DOWEL HOLES (STRAND LAYOUT NOT SHOWN). INTERIOR SLAB SECTION SHOWN-EXTERIOR SLAB SECTION SIMILAR EXCEPT SHEAR KEY LOCATION.

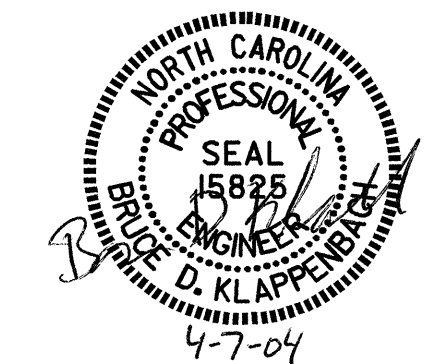

PROJECT NO. R-2514A  
ON SLOW COUNTY  
STATION: 182+87.400-L-MED

SHEET 1 OF 5

STATE OF NORTH CAROLINA  
DEPARTMENT OF TRANSPORTATION  
RALEIGH  
914mm X 533mm  
PRESTRESSED CONCRETE  
CORED SLAB UNIT  
(LEFT LANE)

REVISIONS						SHEET NO. S-4
NO.	BY:	DATE:	NO.	BY:	DATE:	
1			3			TOTAL SHEETS 46
2			4			

DRAWN BY: M. G. SHAIKH DATE: 3-7-03  
CHECKED BY: D. A. GLADDEN DATE: 4-28-03