

NOTES

STIRRUPS IN CAP MAY BE SHIFTED AS NECESSARY TO CLEAR DOWELS.

PIPE DRAINS MAY BE SHIFTED SLIGHTLY AS NECESSARY TO CLEAR REINFORCING STEEL AND DOWELS.

THE LATERAL GUIDE AT EACH END OF THE CAP IS NOT TO BE POURED UNTIL AFTER THE CORED SLAB UNITS ARE IN PLACE.

THE CONTRACTOR SHALL PROVIDE FOR INSTALLATION OF THE 102mm DIAMETER DRAIN PIPE THROUGH THE WING WALL AS REQUIRED FOR REINFORCED BRIDGE APPROACH FILLS, SEE THE ROADWAY PLANS. REINFORCING STEEL IN THE WING WALL MAY BE SHIFTED AS NECESSARY TO CLEAR THE DRAIN PIPE.

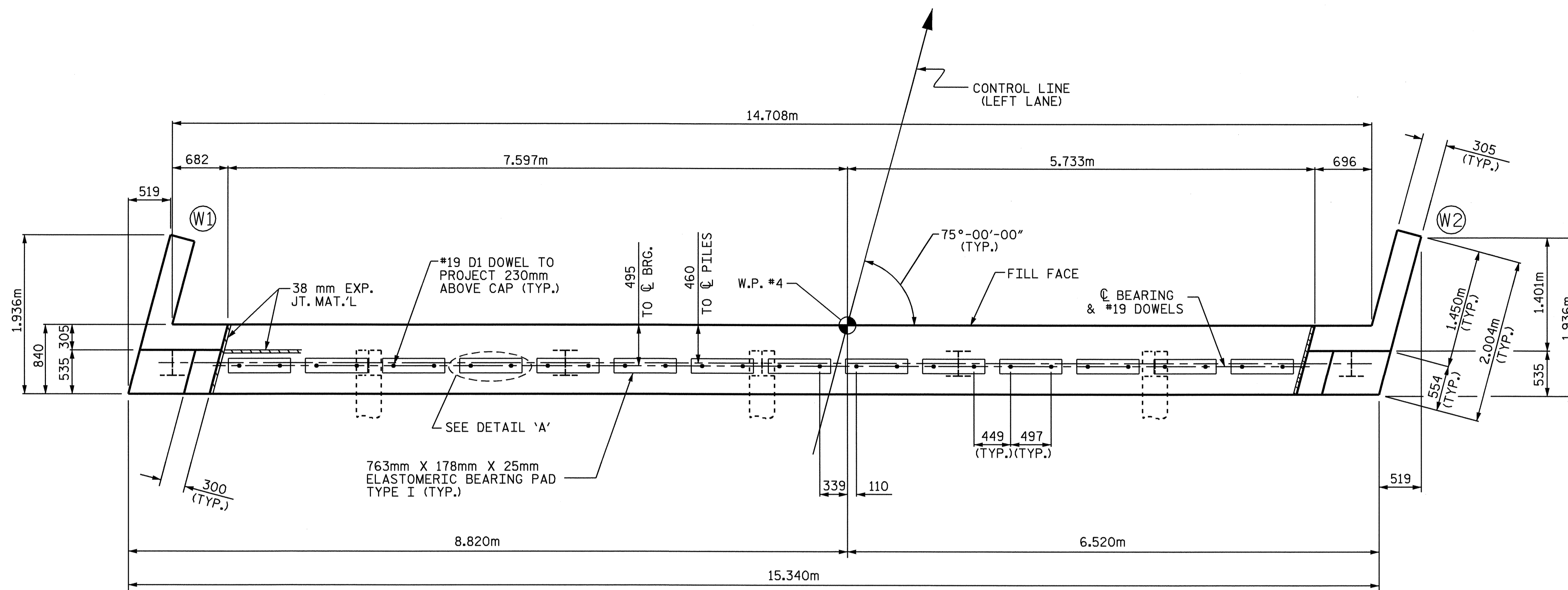

PLAN

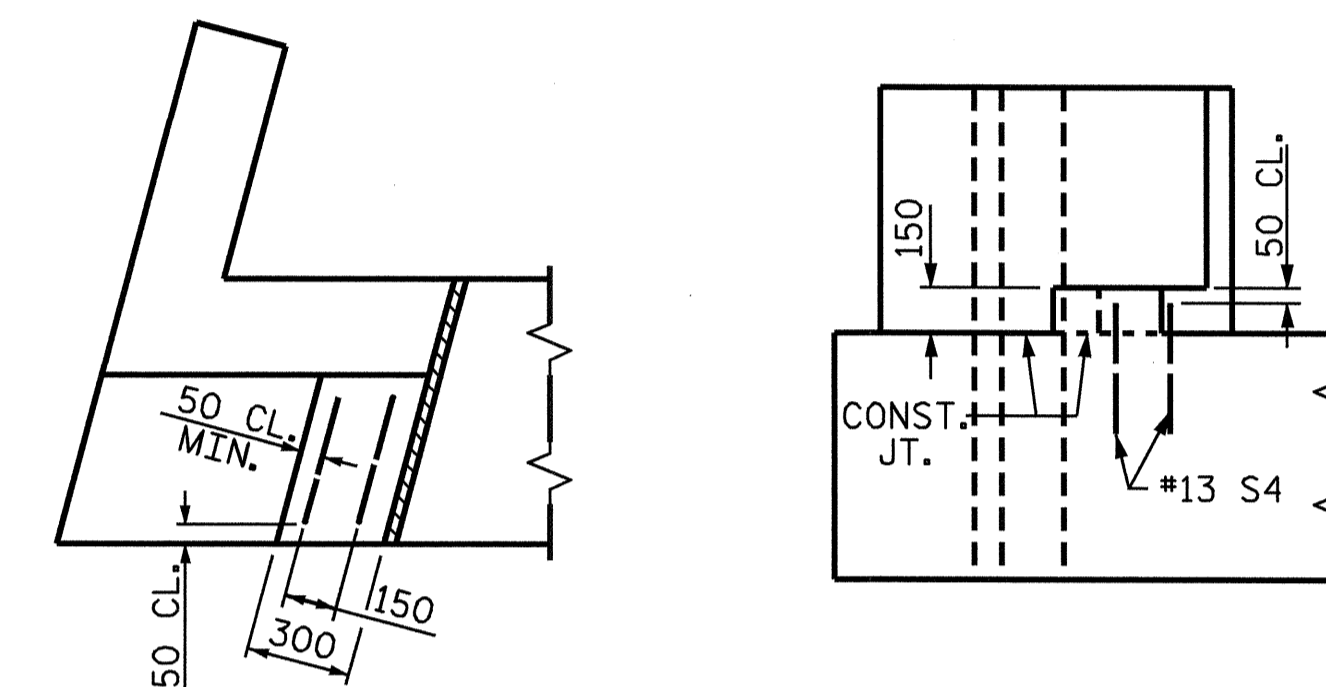

PLAN

ELEVATION

LATERAL GUIDE DETAILS

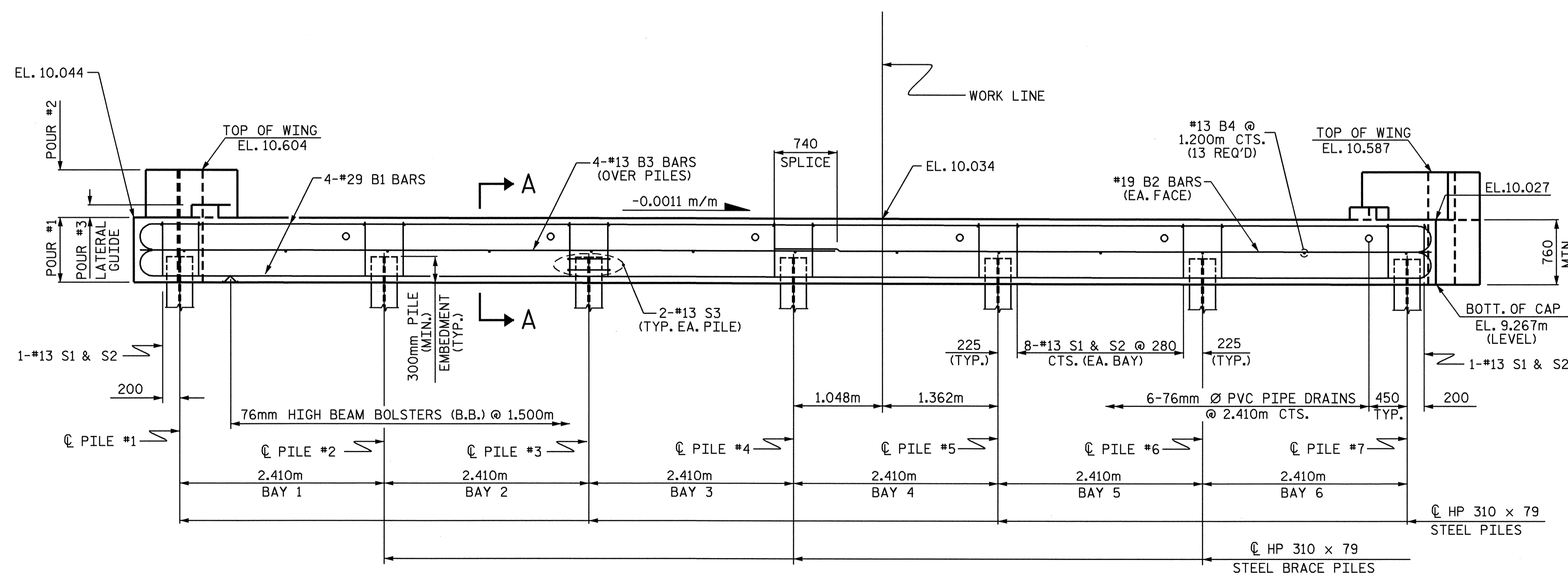

ELEVATION

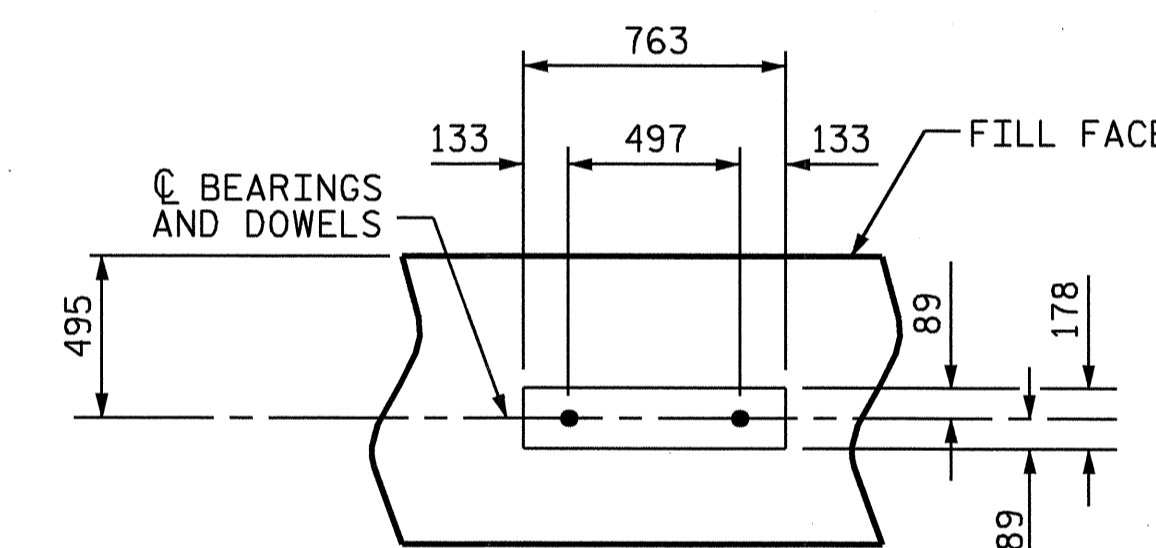

DETAIL "A"

PROJECT NO. R-2514A
ONSLOW COUNTY
 STATION: 182+87.40 -L- MED.

SHEET 1 OF 3

STATE OF NORTH CAROLINA
 DEPARTMENT OF TRANSPORTATION
 RALEIGH

**SUBSTRUCTURE
 END BENT #2
 (LEFT LANE)**

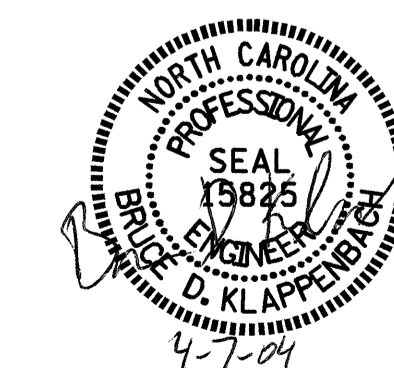

REVISIONS					SHEET NO. S-16
NO.	BY:	DATE:	NO.	DATE:	
1			3		TOTAL SHEETS 46
2			4		

DRAWN BY : J.B. WILSON DATE : 10/03
 CHECKED BY : G.M. Patterson DATE : 11/03

07-APR-2004 10:46
 W:\squad\N2514A\Str1and2\jwilson\Microstation\R-2514A.sd_E*2.01.dgn
 jwilson