

**SECTION THRU CAP**

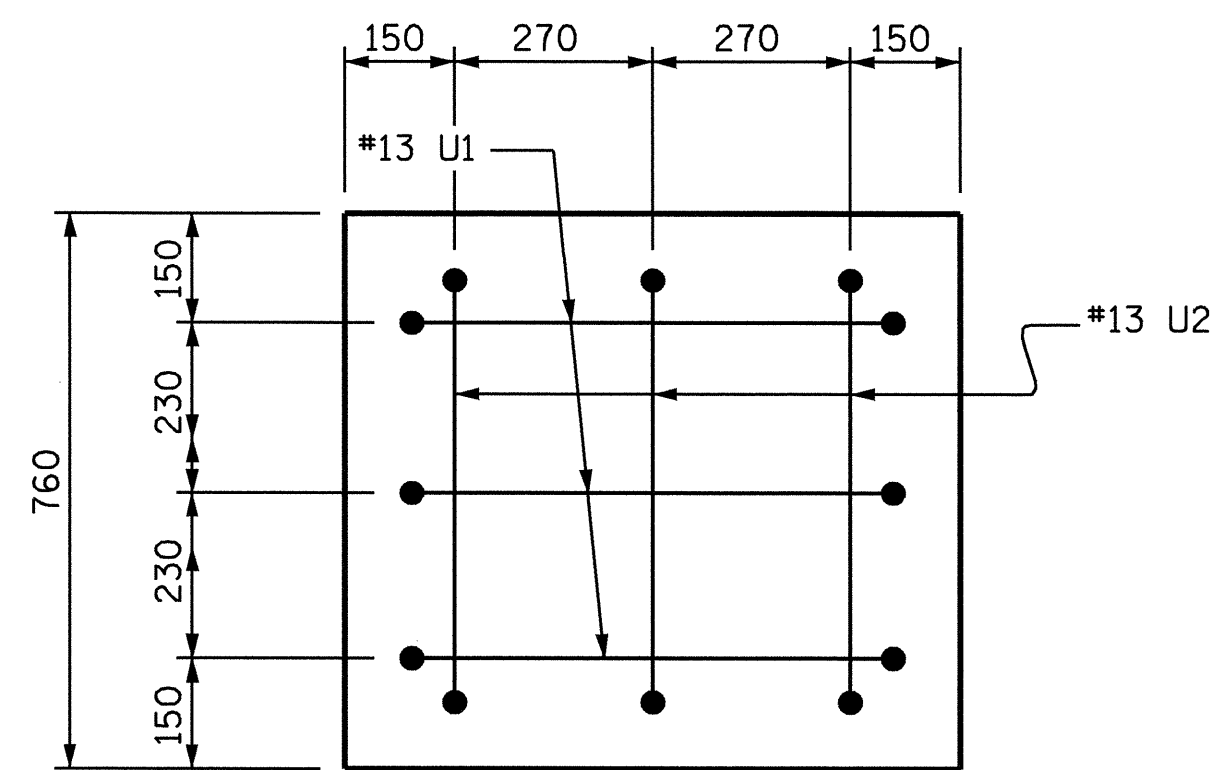

**VIEW "X-X"**

BAR TYPES		BILL OF MATERIAL																																																																																										
		<p><b>BENT #1</b></p> <table border="1"> <thead> <tr> <th>BAR NO.</th> <th>SIZE</th> <th>TYPE</th> <th>LENGTH</th> <th>WEIGHT</th> </tr> </thead> <tbody> <tr><td>B1</td><td>4</td><td>#32</td><td>1</td><td>14940</td><td>383</td></tr> <tr><td>B2</td><td>4</td><td>#32</td><td>STR</td><td>14120</td><td>362</td></tr> <tr><td>B3</td><td>16</td><td>#13</td><td>STR</td><td>7440</td><td>118</td></tr> <tr><td>B4</td><td>16</td><td>#13</td><td>STR</td><td>740</td><td>12</td></tr> <tr><td>D1</td><td>56</td><td>#19</td><td>STR</td><td>460</td><td>58</td></tr> <tr><td>S1</td><td>54</td><td>#16</td><td>2</td><td>2320</td><td>194</td></tr> <tr><td>S2</td><td>16</td><td>#13</td><td>3</td><td>1980</td><td>31</td></tr> <tr><td>S3</td><td>2</td><td>#13</td><td>4</td><td>780</td><td>2</td></tr> <tr><td>S4</td><td>2</td><td>#13</td><td>4</td><td>840</td><td>2</td></tr> <tr><td>S5</td><td>2</td><td>#13</td><td>4</td><td>900</td><td>2</td></tr> <tr><td>S6</td><td>2</td><td>#13</td><td>4</td><td>980</td><td>2</td></tr> <tr><td>U1</td><td>6</td><td>#13</td><td>4</td><td>1300</td><td>8</td></tr> <tr><td>U2</td><td>6</td><td>#13</td><td>4</td><td>1200</td><td>7</td></tr> <tr><td>U3</td><td>2</td><td>#29</td><td>4</td><td>2920</td><td>30</td></tr> </tbody> </table>		BAR NO.	SIZE	TYPE	LENGTH	WEIGHT	B1	4	#32	1	14940	383	B2	4	#32	STR	14120	362	B3	16	#13	STR	7440	118	B4	16	#13	STR	740	12	D1	56	#19	STR	460	58	S1	54	#16	2	2320	194	S2	16	#13	3	1980	31	S3	2	#13	4	780	2	S4	2	#13	4	840	2	S5	2	#13	4	900	2	S6	2	#13	4	980	2	U1	6	#13	4	1300	8	U2	6	#13	4	1200	7	U3	2	#29	4	2920	30
BAR NO.	SIZE	TYPE	LENGTH	WEIGHT																																																																																								
B1	4	#32	1	14940	383																																																																																							
B2	4	#32	STR	14120	362																																																																																							
B3	16	#13	STR	7440	118																																																																																							
B4	16	#13	STR	740	12																																																																																							
D1	56	#19	STR	460	58																																																																																							
S1	54	#16	2	2320	194																																																																																							
S2	16	#13	3	1980	31																																																																																							
S3	2	#13	4	780	2																																																																																							
S4	2	#13	4	840	2																																																																																							
S5	2	#13	4	900	2																																																																																							
S6	2	#13	4	980	2																																																																																							
U1	6	#13	4	1300	8																																																																																							
U2	6	#13	4	1200	7																																																																																							
U3	2	#29	4	2920	30																																																																																							
		<table border="1"> <tbody> <tr><td>U1</td><td>700</td></tr> <tr><td>U2</td><td>600</td></tr> <tr><td>U3</td><td>680</td></tr> <tr><td>S6</td><td>380</td></tr> <tr><td>S5</td><td>300</td></tr> <tr><td>S4</td><td>240</td></tr> <tr><td>S3</td><td>180</td></tr> </tbody> </table>		U1	700	U2	600	U3	680	S6	380	S5	300	S4	240	S3	180																																																																											
U1	700																																																																																											
U2	600																																																																																											
U3	680																																																																																											
S6	380																																																																																											
S5	300																																																																																											
S4	240																																																																																											
S3	180																																																																																											
		<table border="1"> <tbody> <tr><td>U1, U2 &amp; S3 THRU S6</td><td>1120</td></tr> <tr><td>U3</td><td>300</td></tr> </tbody> </table>		U1, U2 & S3 THRU S6	1120	U3	300																																																																																					
U1, U2 & S3 THRU S6	1120																																																																																											
U3	300																																																																																											
		<p>REINFORCING STEEL = 1211 KG</p>																																																																																										
<p>ALL BAR DIMENSIONS ARE OUT TO OUT</p>		<p>CLASS "A" CONCRETE BREAKDOWN</p> <table border="1"> <tbody> <tr><td>POUR #1 (CAP)</td><td>= 9.1</td><td>m<sup>3</sup></td></tr> <tr><td>POUR #2 (LATERAL GUIDE)</td><td>= 0.1</td><td>m<sup>3</sup></td></tr> <tr><td>CLASS "A" CONCRETE TOTAL</td><td>= 9.2</td><td>m<sup>3</sup></td></tr> </tbody> </table>		POUR #1 (CAP)	= 9.1	m <sup>3</sup>	POUR #2 (LATERAL GUIDE)	= 0.1	m <sup>3</sup>	CLASS "A" CONCRETE TOTAL	= 9.2	m <sup>3</sup>																																																																																
POUR #1 (CAP)	= 9.1	m <sup>3</sup>																																																																																										
POUR #2 (LATERAL GUIDE)	= 0.1	m <sup>3</sup>																																																																																										
CLASS "A" CONCRETE TOTAL	= 9.2	m <sup>3</sup>																																																																																										
<p>HP 310 X 79 STEEL PILES</p> <p>NO. 8 120.0 m</p>		<p>GALVANIZING STEEL PILES LUMP SUM</p>																																																																																										

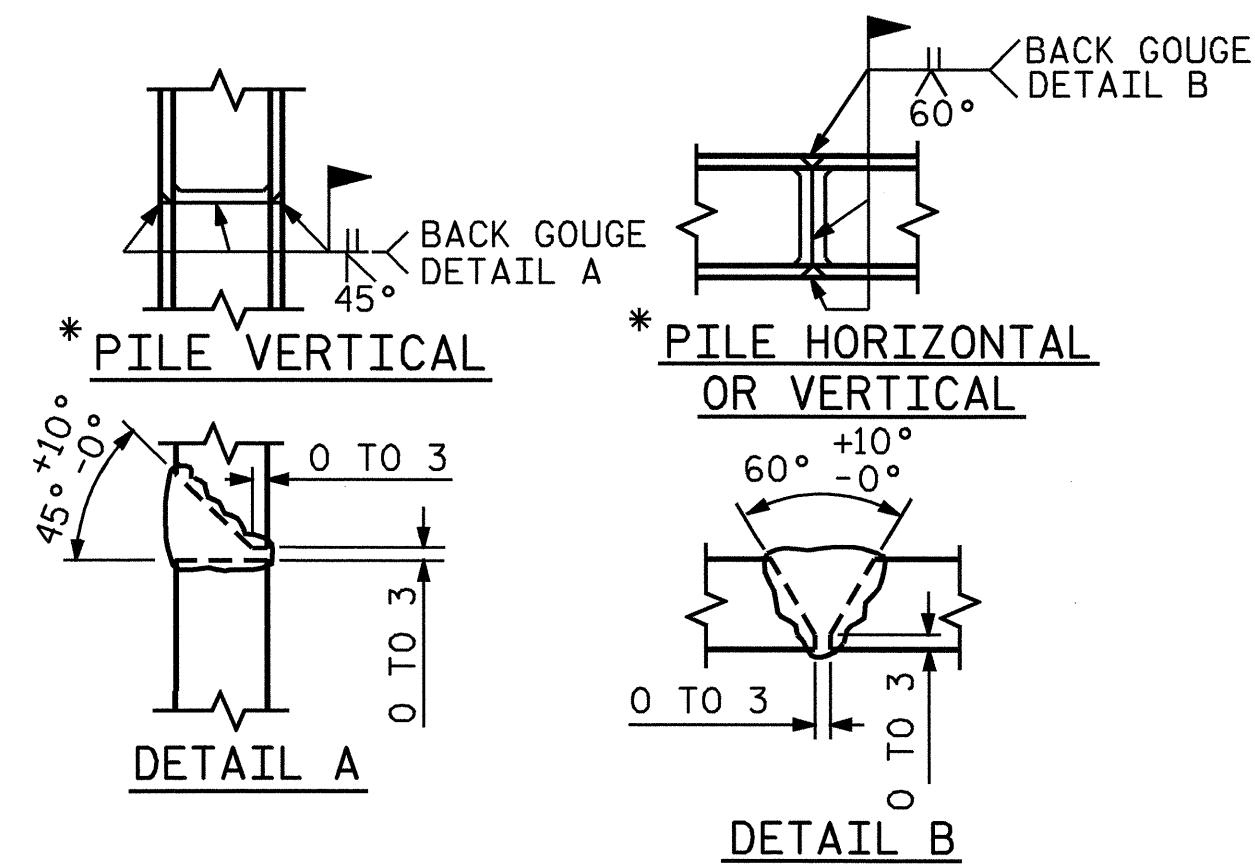

**PILE SPLICE DETAILS**

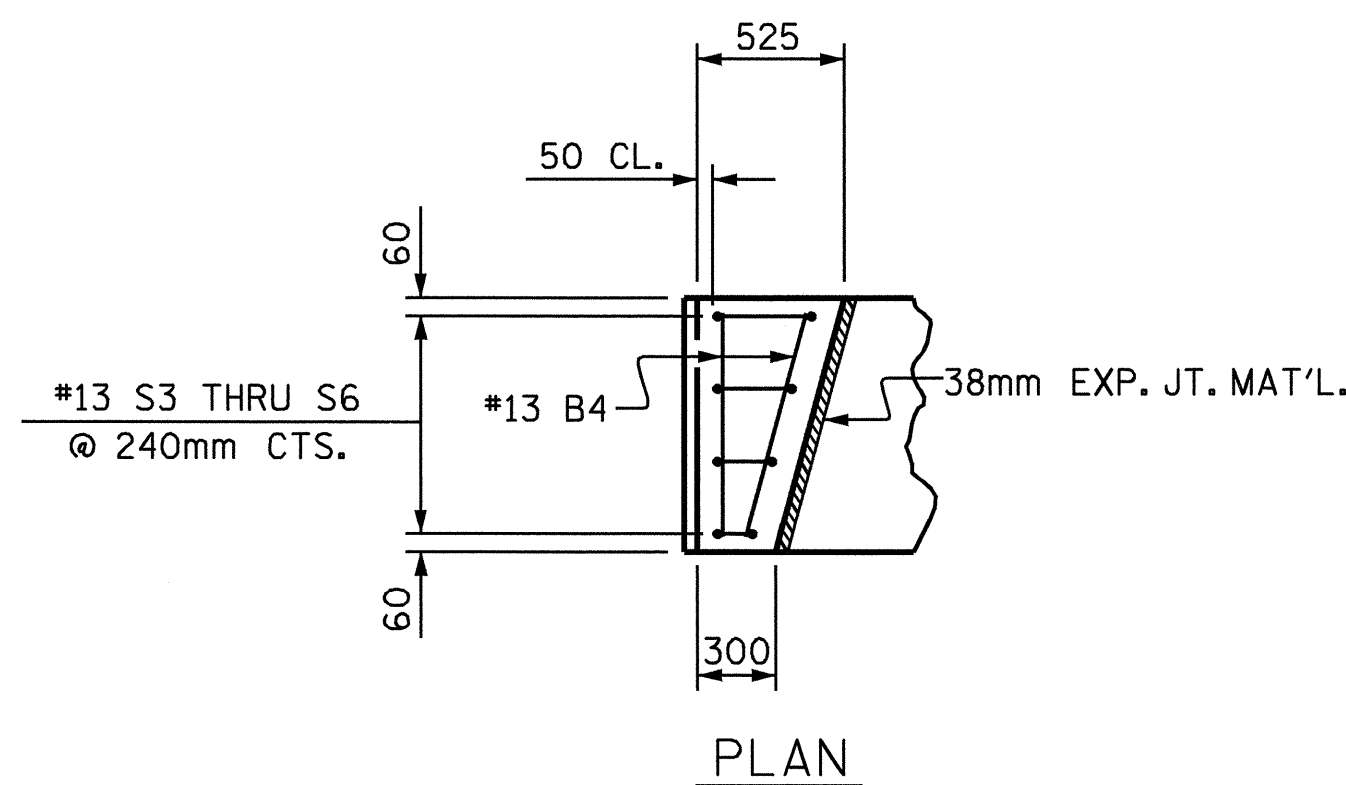

**PLAN**

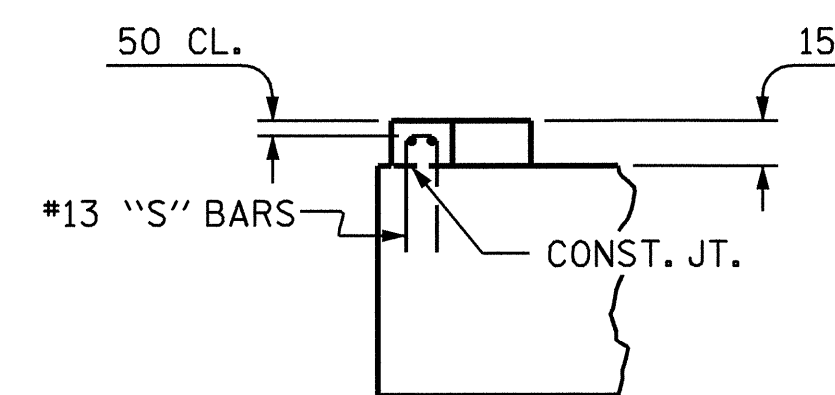

**ELEVATION**

**LATERAL GUIDE DETAILS**

PROJECT NO. R-2514A  
 ONSLOW COUNTY  
 STATION: 182+87.400-L-MED

SHEET 2 OF 2

STATE OF NORTH CAROLINA  
 DEPARTMENT OF TRANSPORTATION  
 RALEIGH

SUBSTRUCTURE  
 BENT #1  
 RIGHT LANE

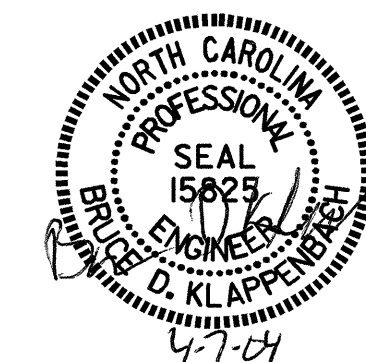

DRAWN BY: D. A. GLADDEN DATE: 10-31-03  
 CHECKED BY: G.M. Patterson DATE: 12-09-03

07-APR-2004 11:43  
 W:\squad\N2514a\Strland2\dgladden\Microstation\xr2514A\_sd.Bl\_02.dgn  
 dgladden

REVISIONS				SHEET NO.	
NO.	BY:	DATE:	NO.	BY:	DATE:
1			3		
2			4		

STR. #2