

PP 18 X 0.50 STEEL PILE
 (OPEN END)

NOTES

STEEL PILES SHALL MEET THE REQUIREMENTS OF ASTM A252 GRADE 2 AND SHALL BE GALVANIZED IN ACCORDANCE WITH THE STANDARD SPECIFICATIONS. THE DRIVING PLATE, IF REQUIRED, MAY BE GALVANIZED.

THE CONCRETE IN THE PLUG SHALL BE CLASS A CONCRETE.

STEEL PILES SHALL BE EXAMINED FOR DAMAGE OR COLLAPSE AFTER BEING DRIVEN AND PRIOR TO PLACING REINFORCING STEEL AND CONCRETE IN THE TOP OF THE PILE. REJECTED PILES SHALL BE REMOVED OR THE CONTRACTOR SHALL SUBMIT A PROPOSAL TO REPAIR THE PILE.

PILE SPLICES SHALL BE IN ACCORDANCE WITH THE STANDARD SPECIFICATIONS AND AWS D1.1. A MAXIMUM OF 2 PILE SPLICES PER PILE IS ALLOWED.

THE CONTRACTOR WILL NOT BE REQUIRED TO REMOVE THE SOIL FROM WITHIN THE PILES AFTER DRIVING UNLESS IT IS NECESSARY TO OBTAIN THE MINIMUM CONCRETE PLUG.

THE PILES SHALL BE DEWATERED TO THE SATISFACTION OF THE ENGINEER TO THE EXTENT NECESSARY TO OBTAIN THE MINIMUM CONCRETE PLUG WITHOUT FOULING THE CONCRETE.

THE CONCRETE PLUG WITHIN THE PILES SHALL BE FORMED SUCH THAT NO MOVEMENT OF THE REINFORCING STEEL OR CONCRETE OCCURS EITHER DURING OR AFTER THE CONCRETE PLACEMENT. THE CONCRETE PLUG SHALL BE CAST AND SHALL OBTAIN A MINIMUM COMPRESSIVE STRENGTH OF 1500 PSI PRIOR TO PLACING THE CONCRETE IN THE BENT CAP.

THE REINFORCING STEEL AND CLASS A CONCRETE ARE CONSIDERED INCIDENTAL TO THE CONTRACT UNIT PRICE BID PER LINEAR FOOT FOR PP 18 X 0.50 STEEL PILES.

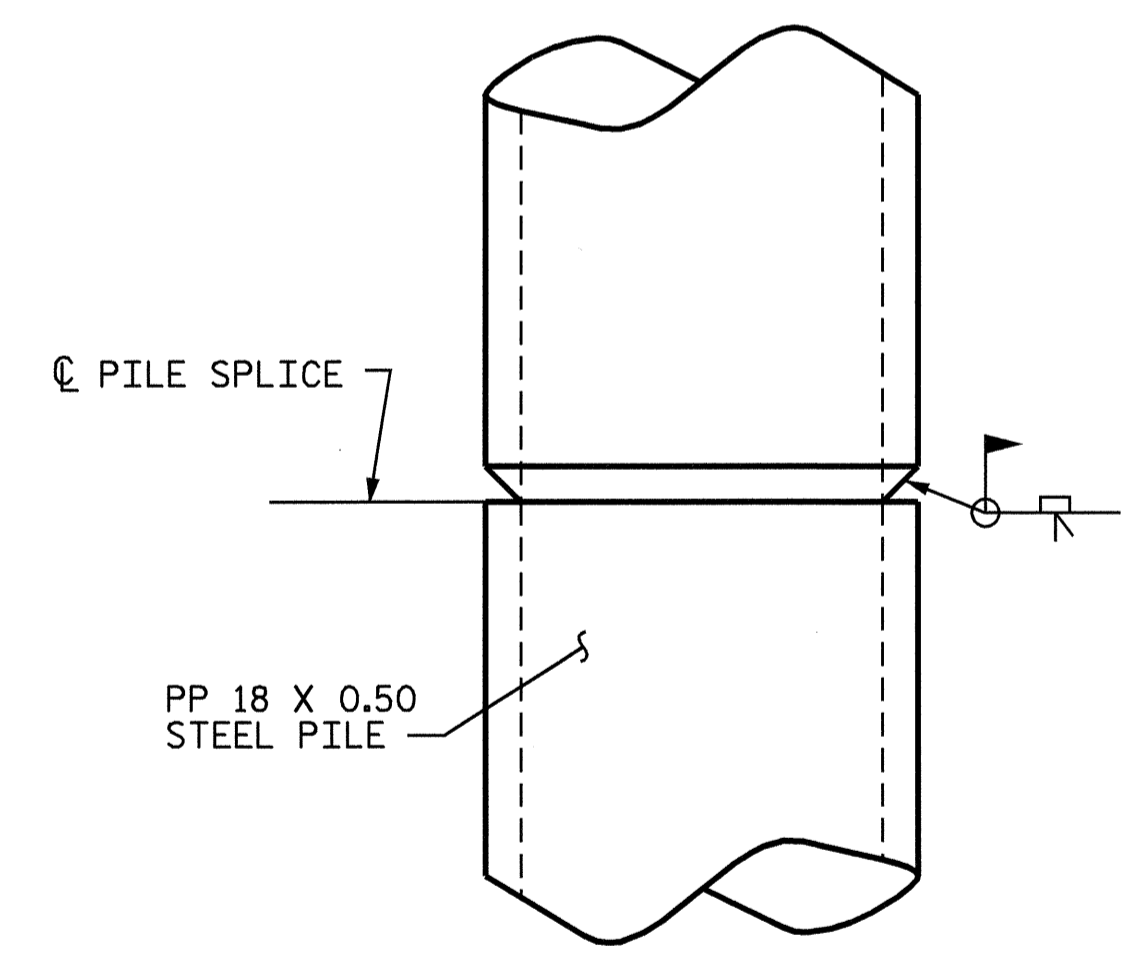

BILL OF MATERIAL FOR ONE
 PP 18 X 0.50 STEEL PILE

BAR	NO.	SIZE	TYPE	LENGTH	WEIGHT
S1	6	#4	1	4'-5"	18
V1	8	#5	2	6'-8"	56
REINFORCING STEEL					74 LBS.
CLASS A CONCRETE					
5'-0" MINIMUM PLUG					0.3 C.Y.

BAR TYPES

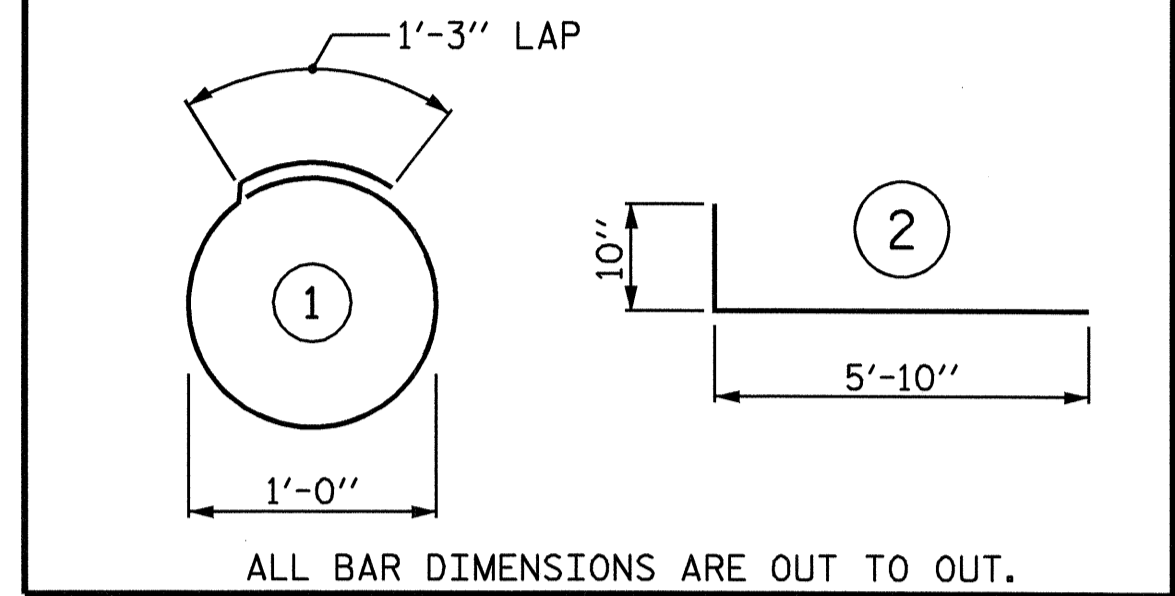

PROJECT NO. B-3470
HAYWOOD COUNTY
 STATION: 15+18.00 -L-

STATE OF NORTH CAROLINA
 DEPARTMENT OF TRANSPORTATION
 RALEIGH
 STANDARD
 18" STEEL PIPE PILE

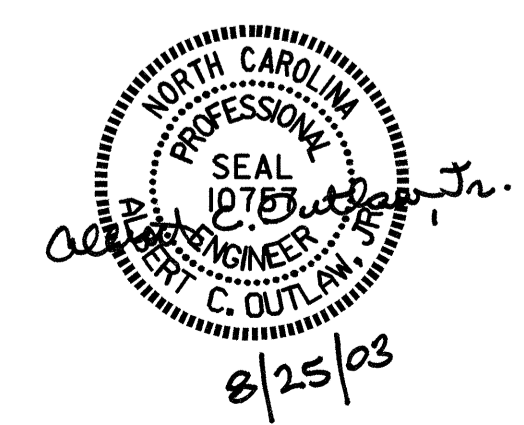

ASSEMBLED BY : P. C. BREWER	DATE : 7/1/03
CHECKED BY : S. B. WILLIAMS	DATE : 7/14/03
DRAWN BY : RWW I/01	REV. 7/10/01 RWW/LES
CHECKED BY : LES I/01	REV. 5/7/03 RWW/JTE

REVISIONS						SHEET NO. S-15
NO.	BY:	DATE:	NO.	BY:	DATE:	
1			3			TOTAL SHEETS 22
2			4			