

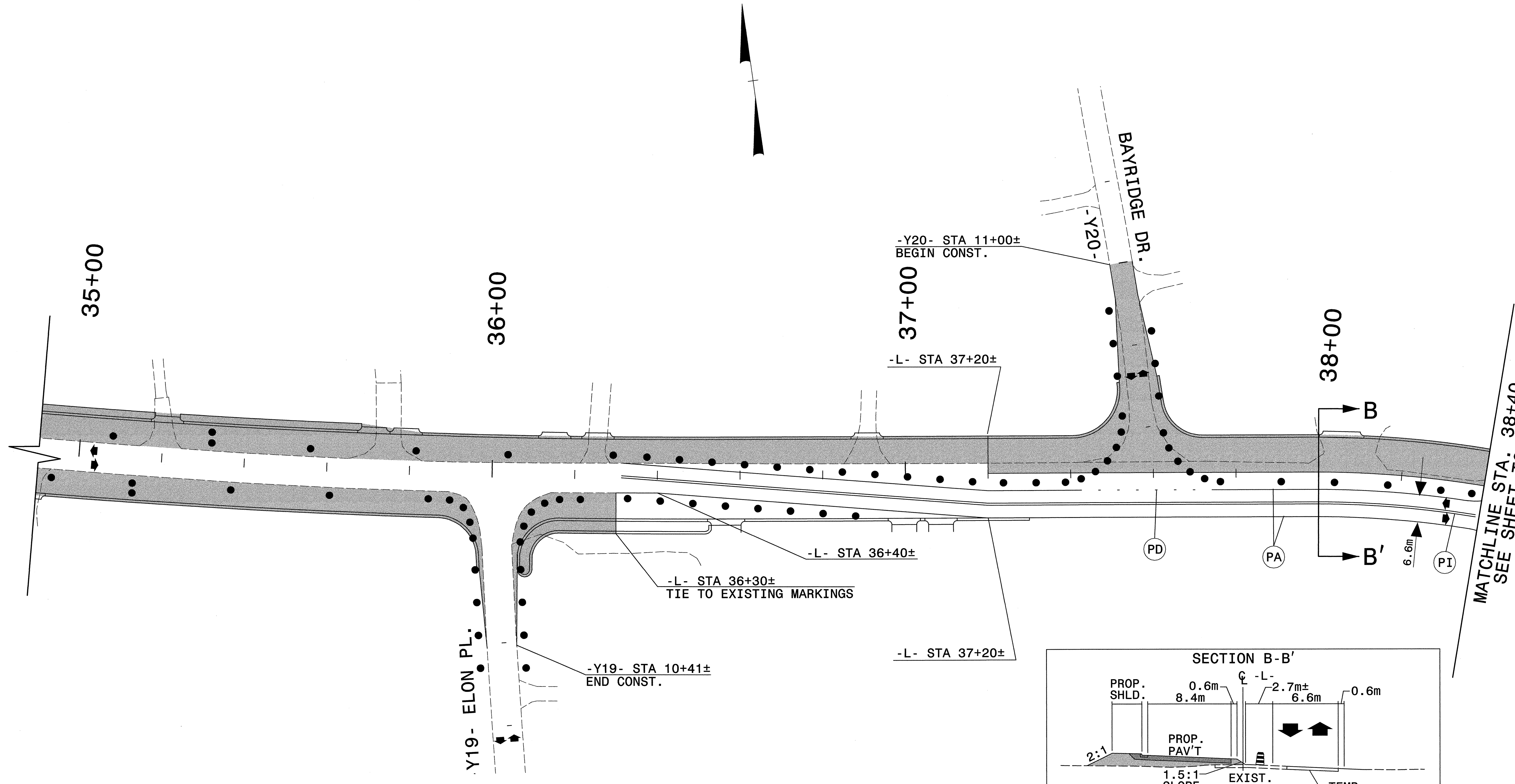

PROJ. REFERENCE NO.	SHEET NO.
U-2717	TCP-16

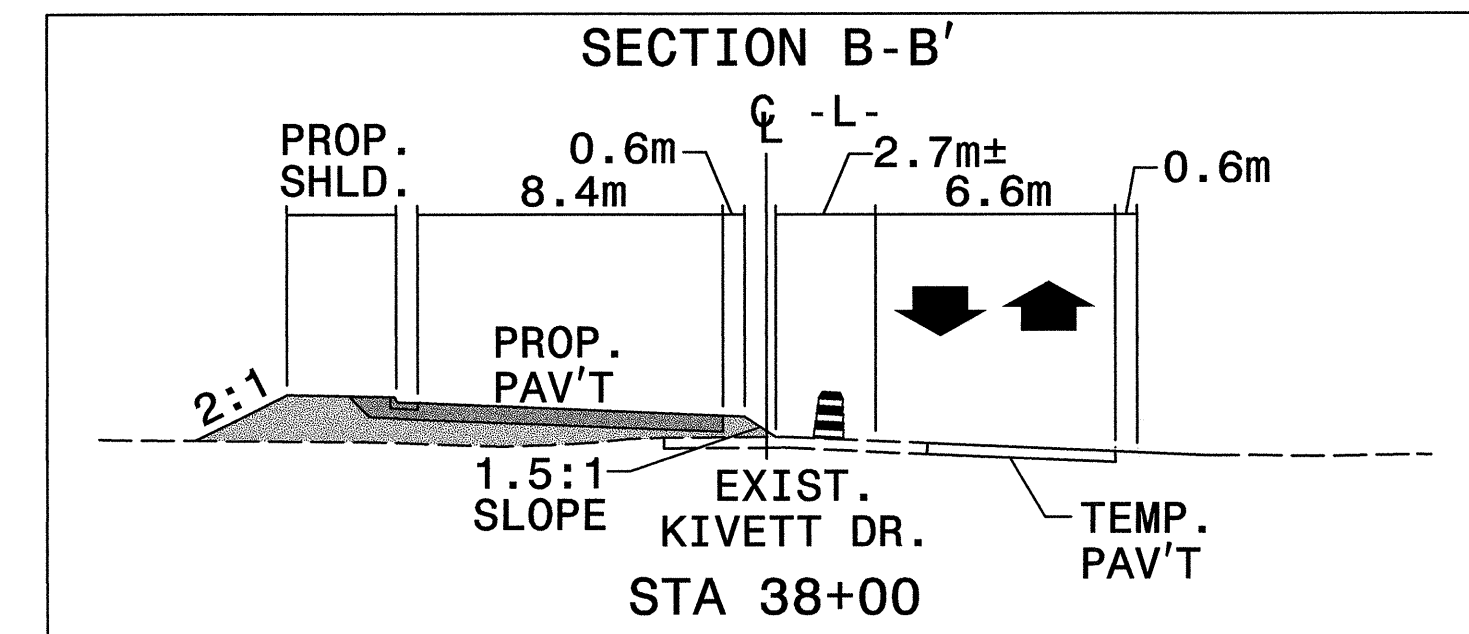

MATCHLINE STA: 38+40
SEE SHEET TCP-17



Plans prepared by:
KO & ASSOCIATES, P.C.
Consulting Engineers
101 SCHAUB DR., SUITE #202
RALEIGH, N.C. 27606
For Division of Highways

APPROVED: *Michael Rzepa* DATE: 6-18-04

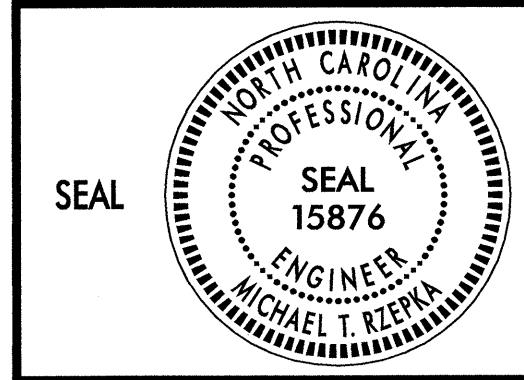

PHASE II DETAIL

SCALE: NONE
DATE: 6-04
DWG. BY: MTR
DESIGN BY: MTR
REVIEWED BY: MSA

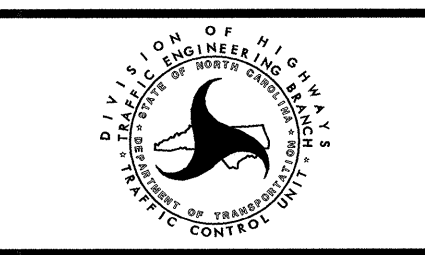

REVISIONS	

p:\mtr\1100-2717\1001\plans\02\3wz.dgn
 06/02/2004 11:59:45 AM