

03-AUG-2004 09:55 B:\wedeking - AT 10196338

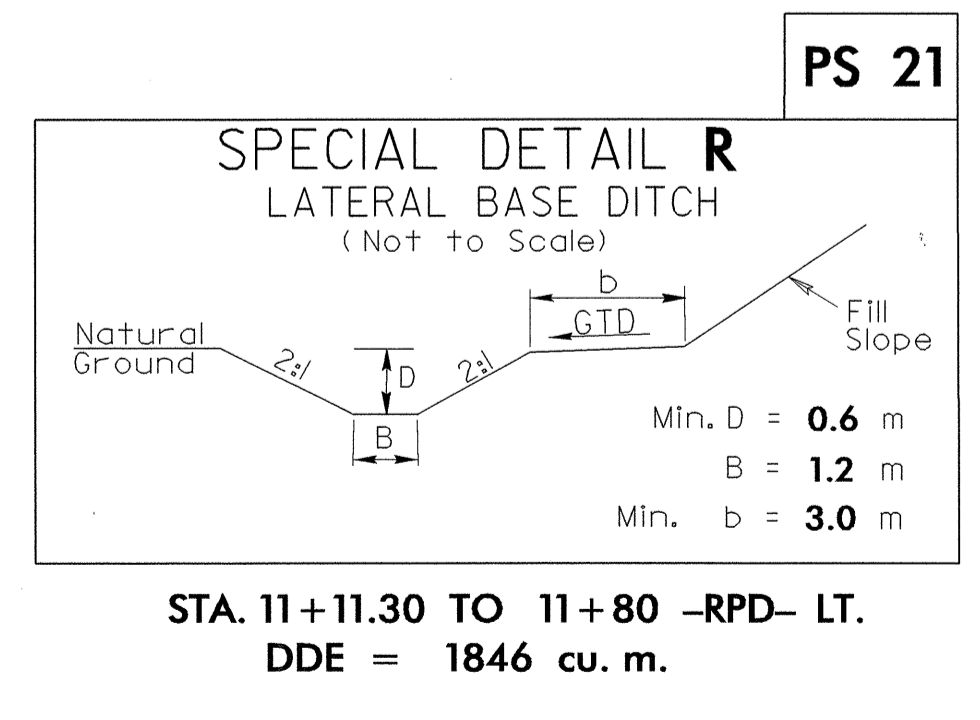
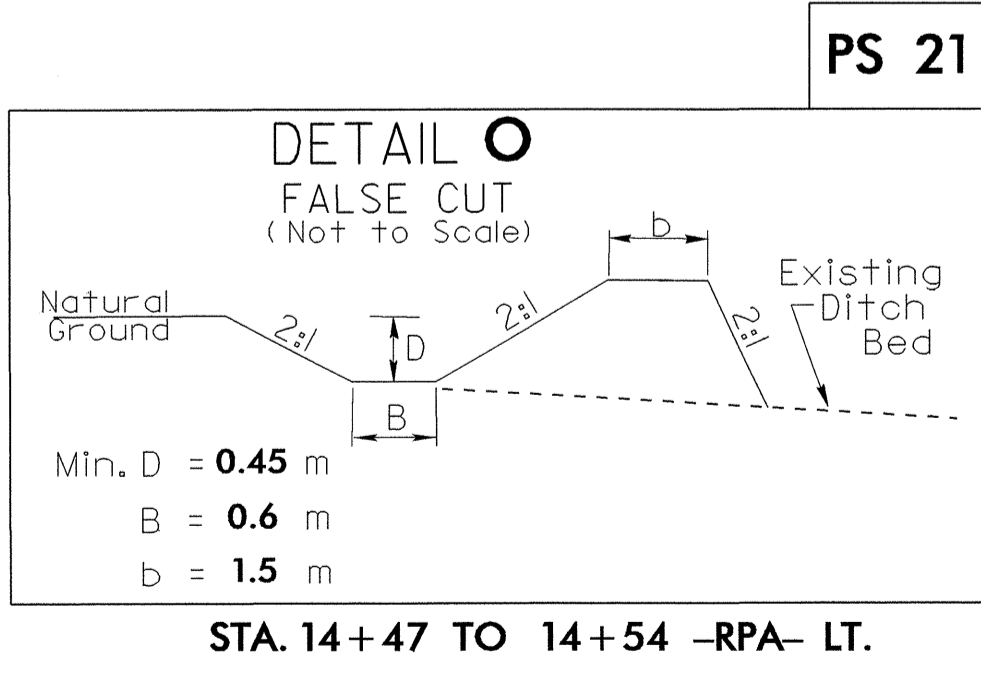
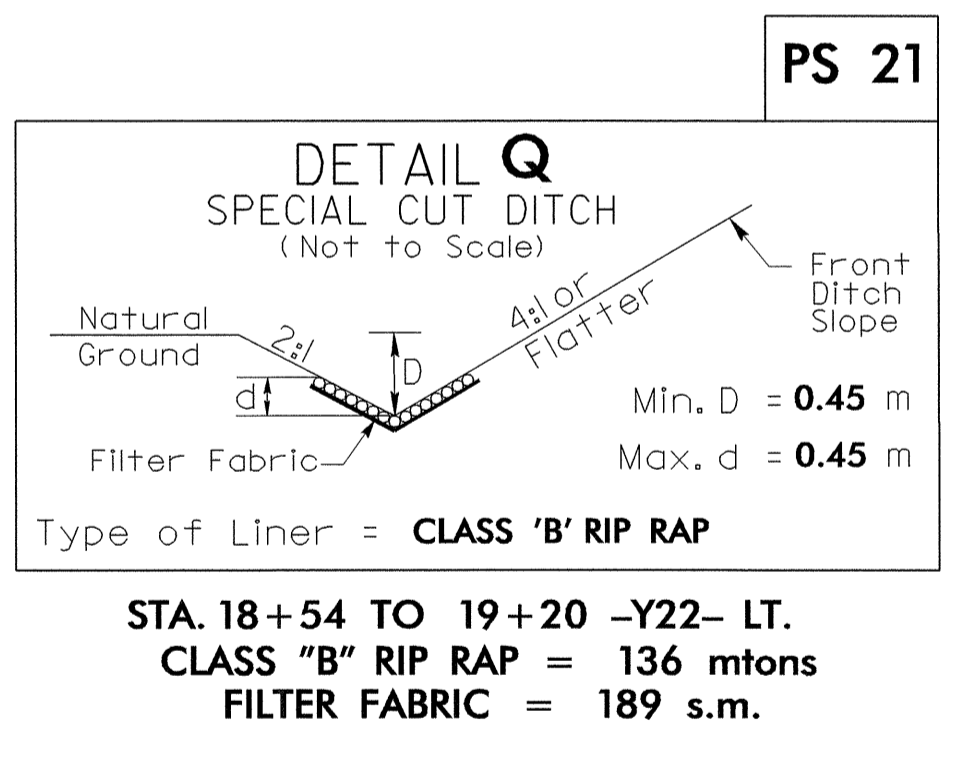
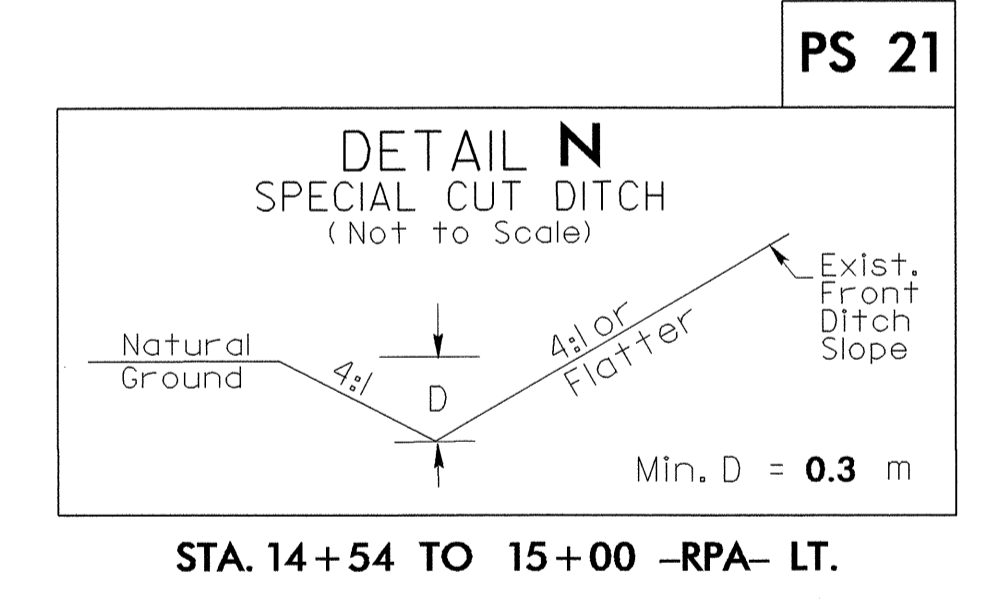
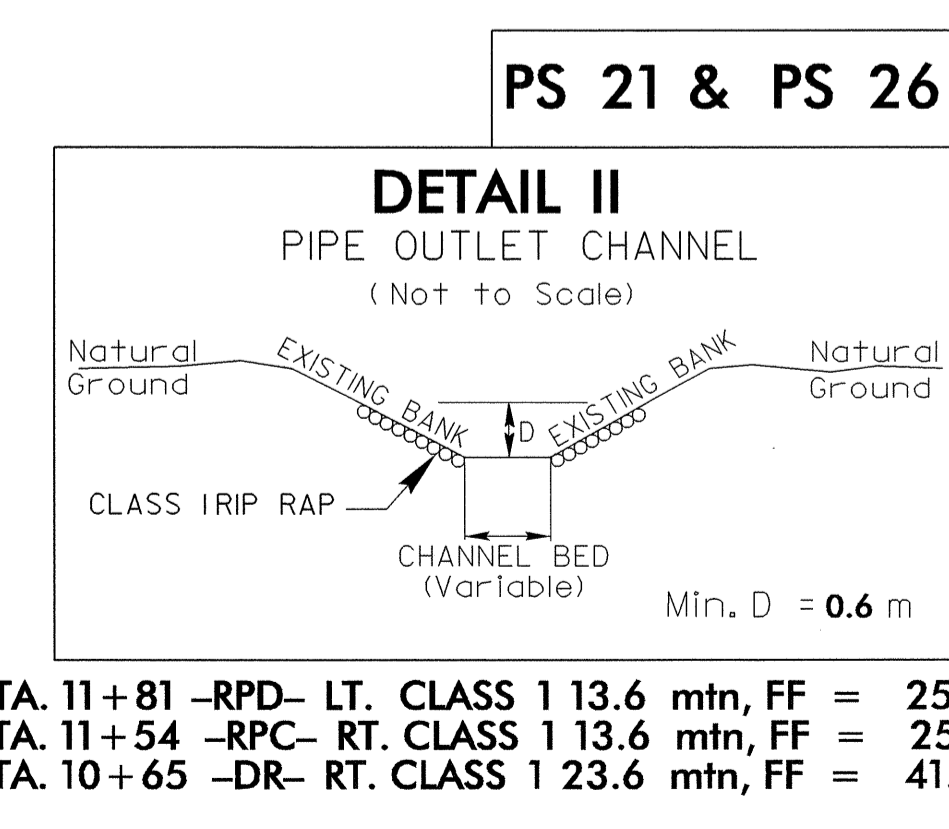
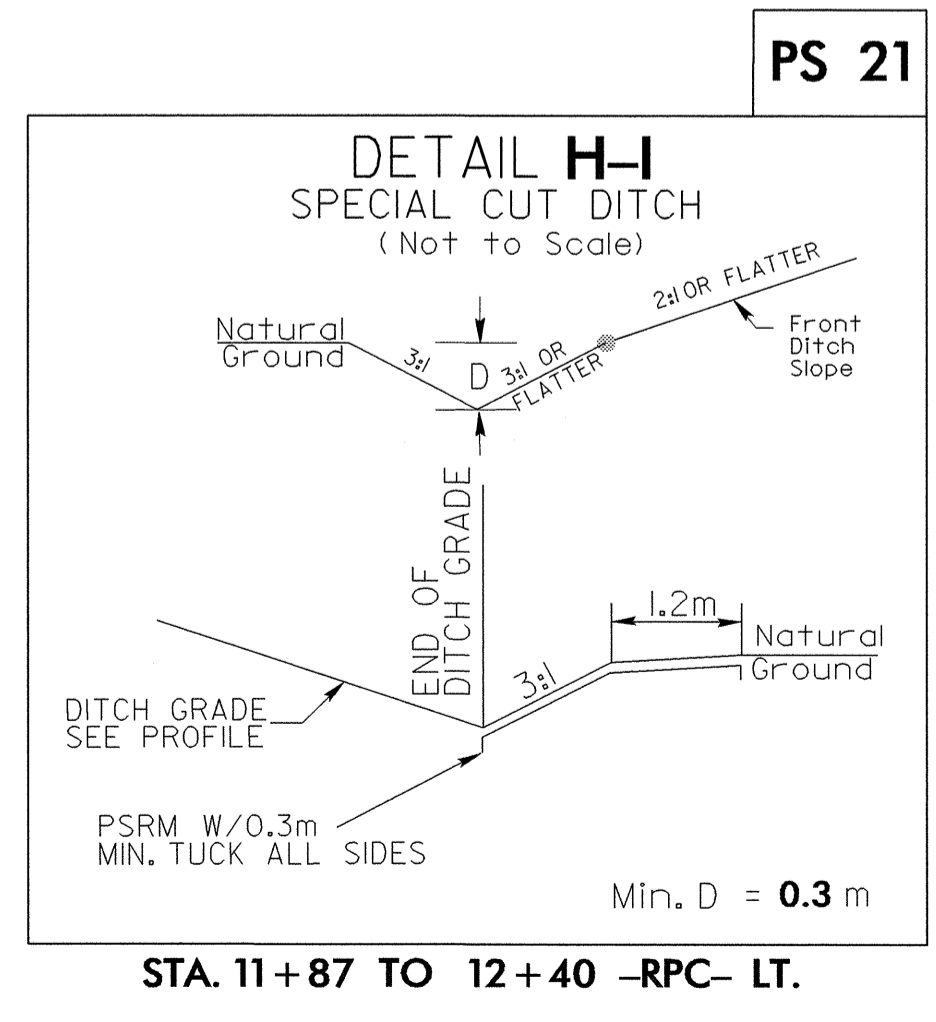
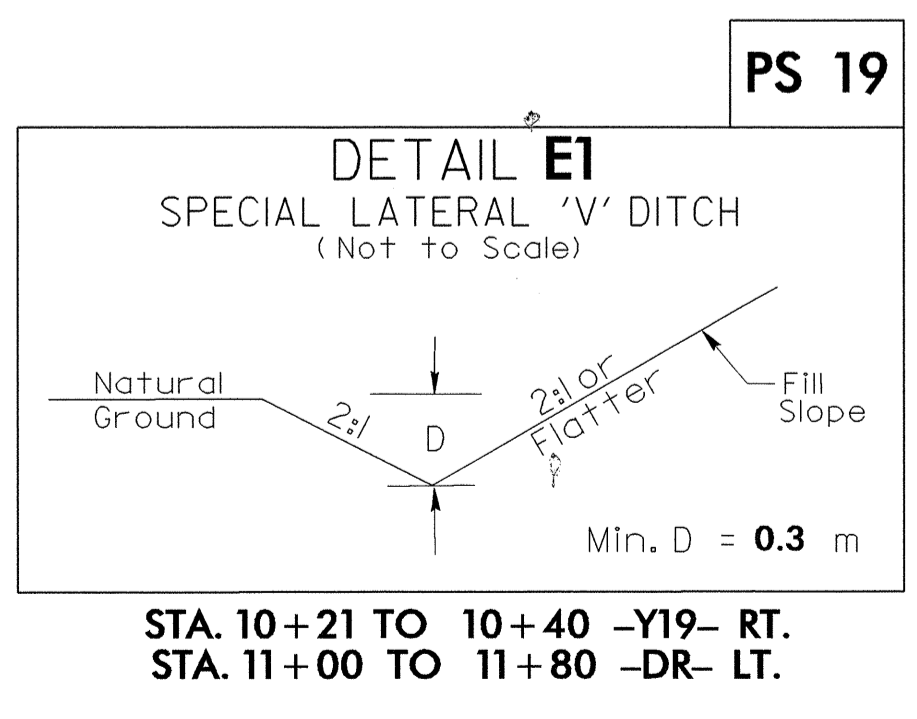
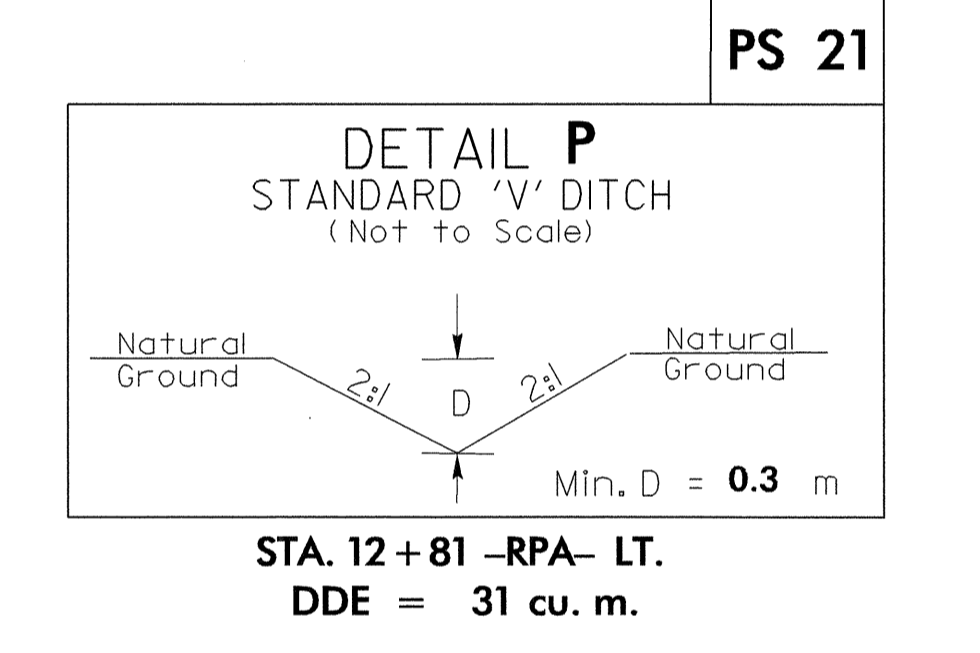
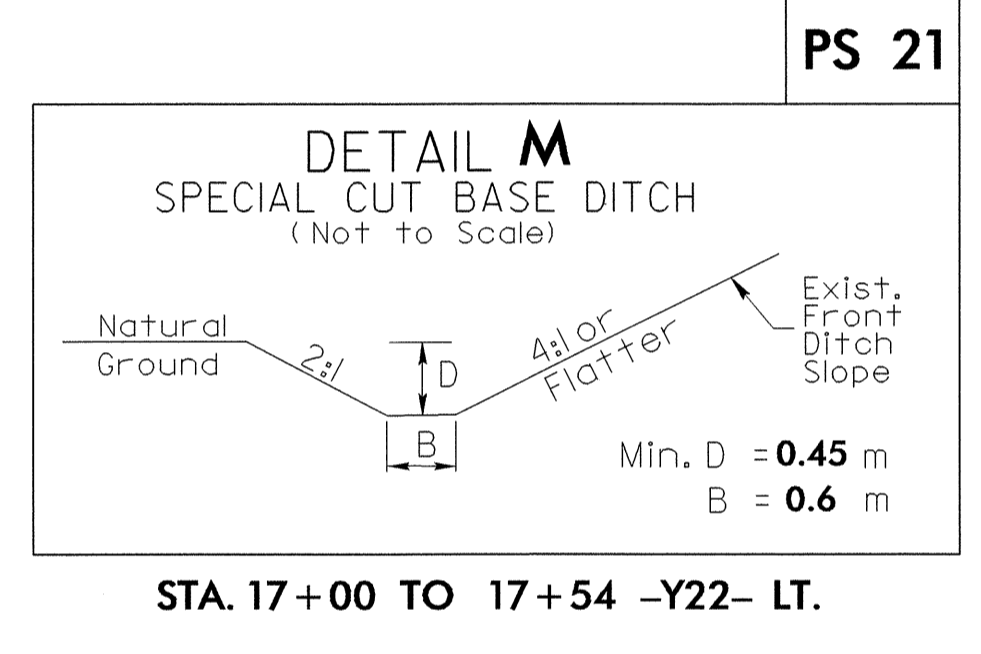
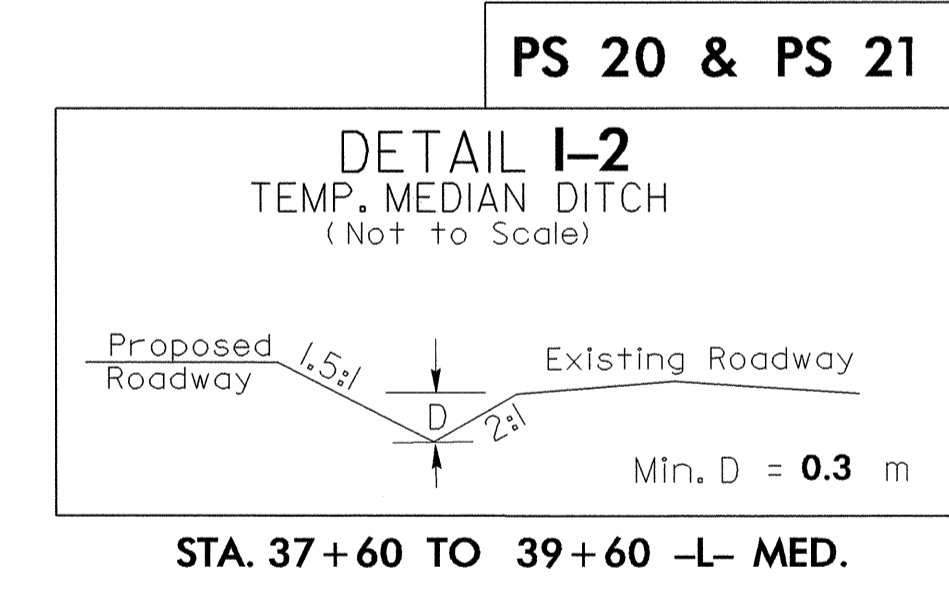
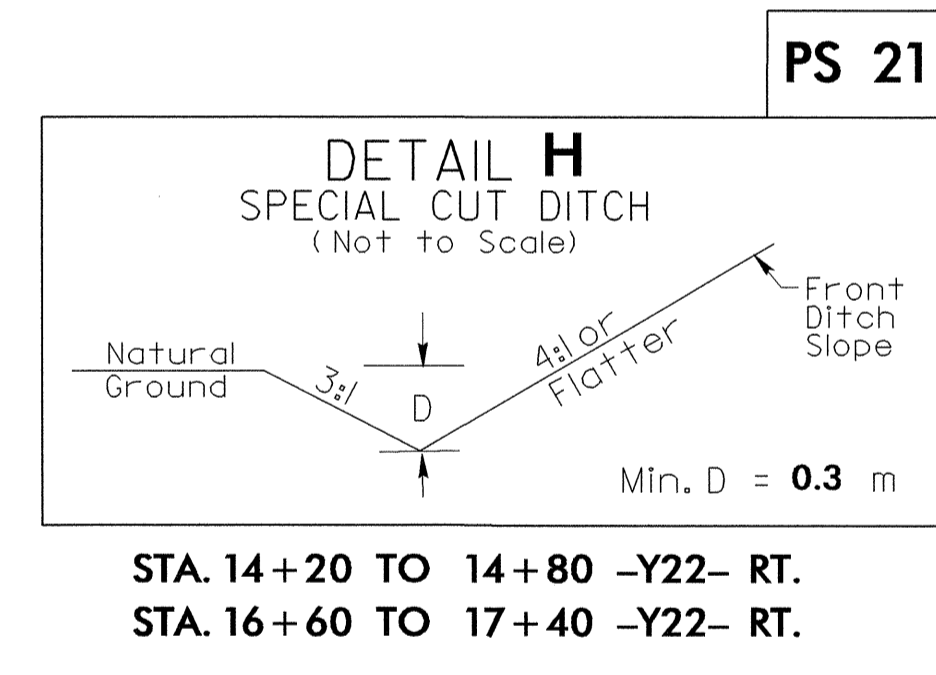
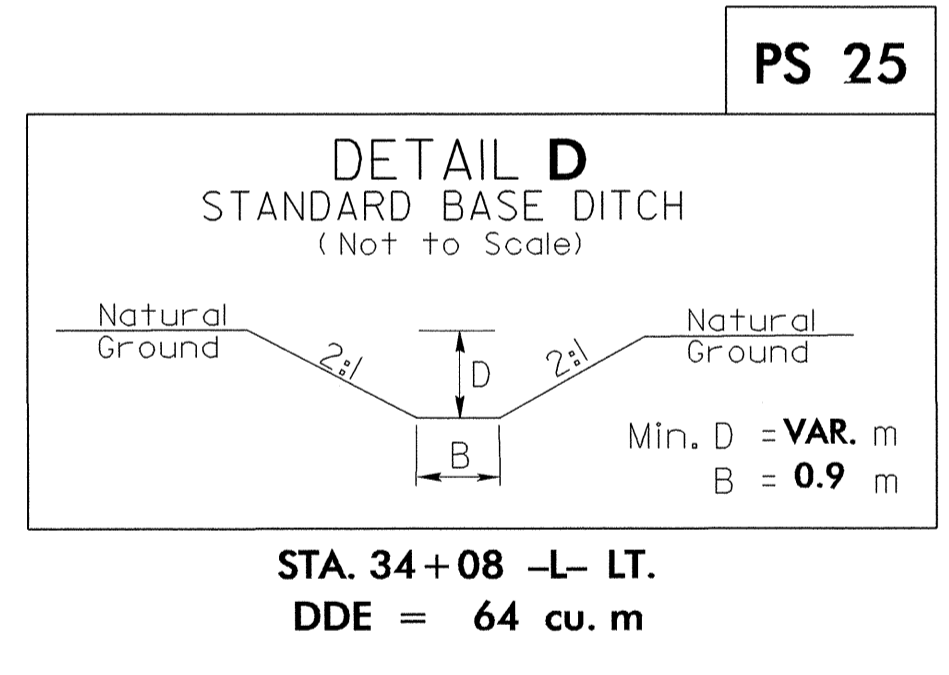
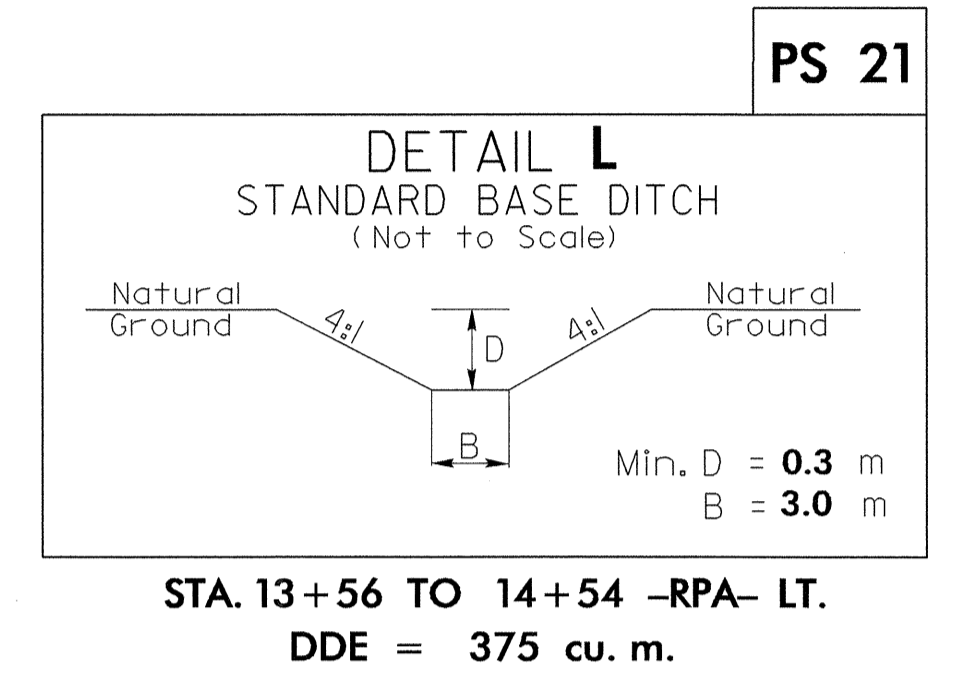
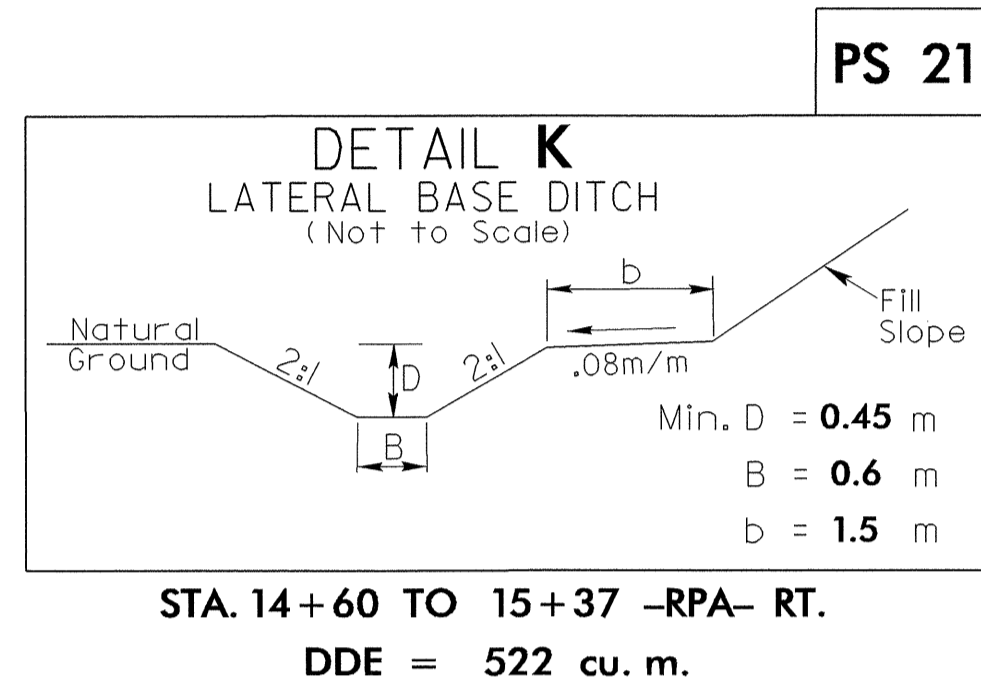
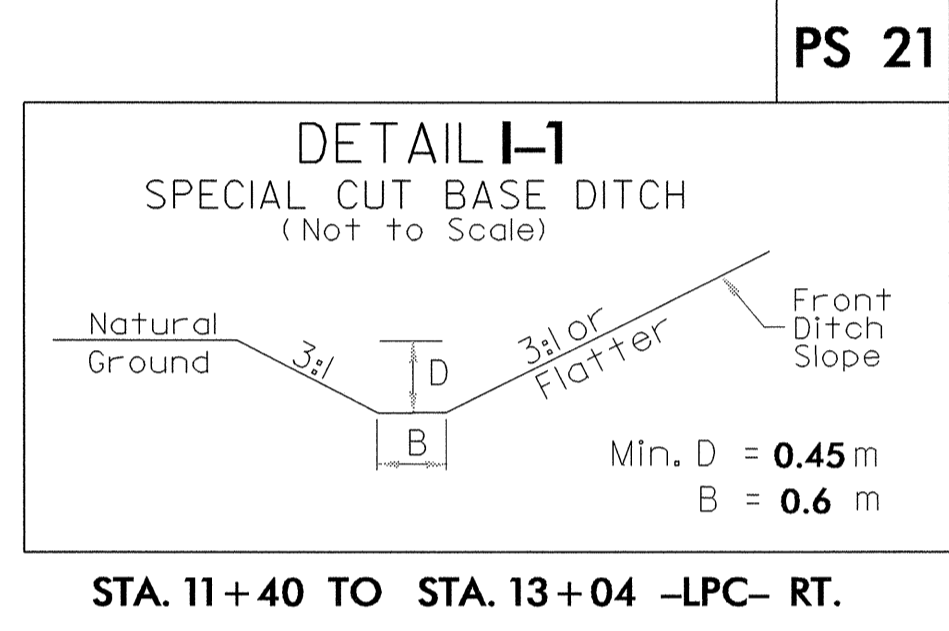
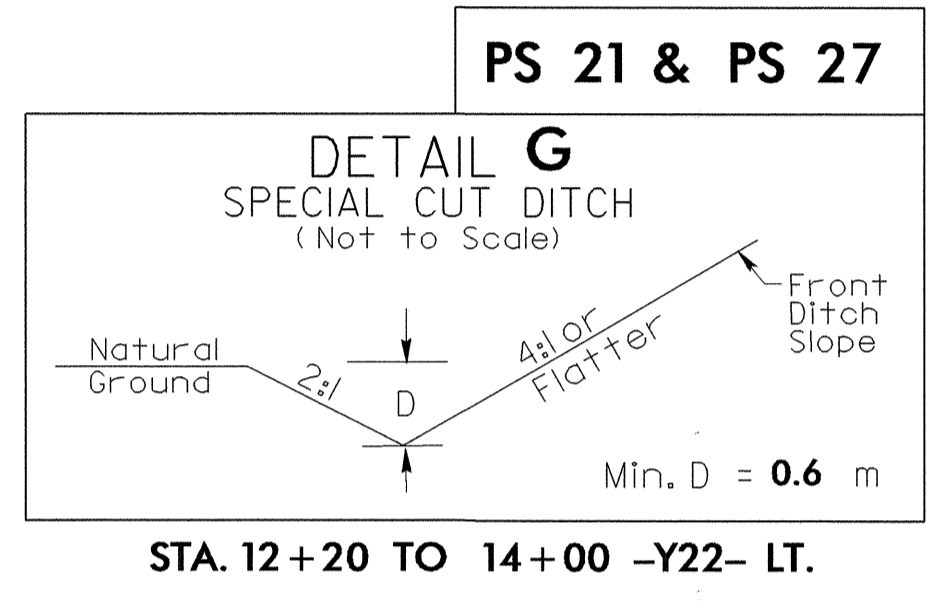
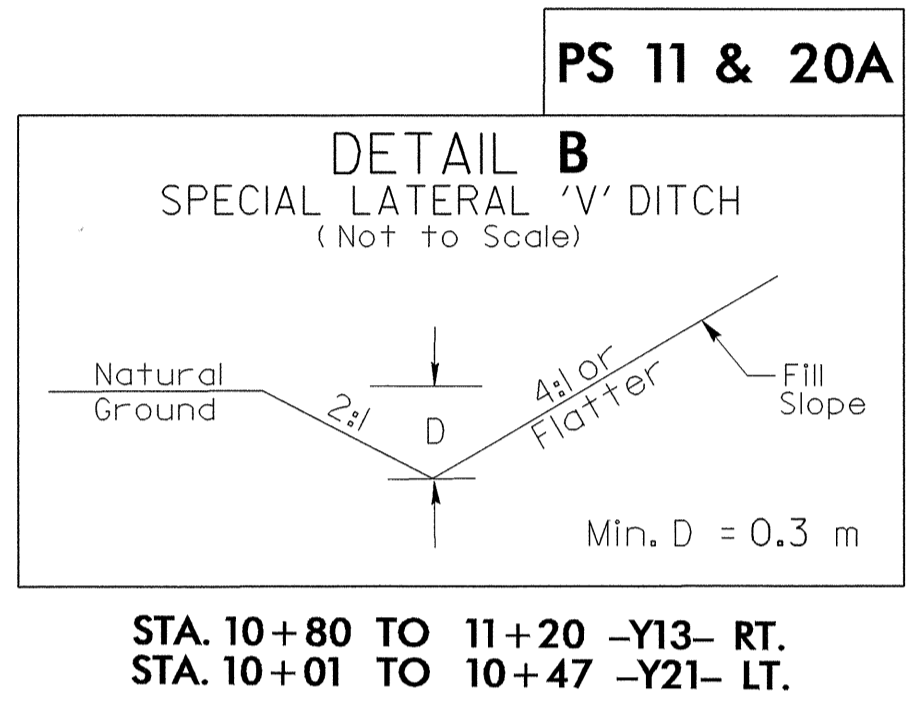
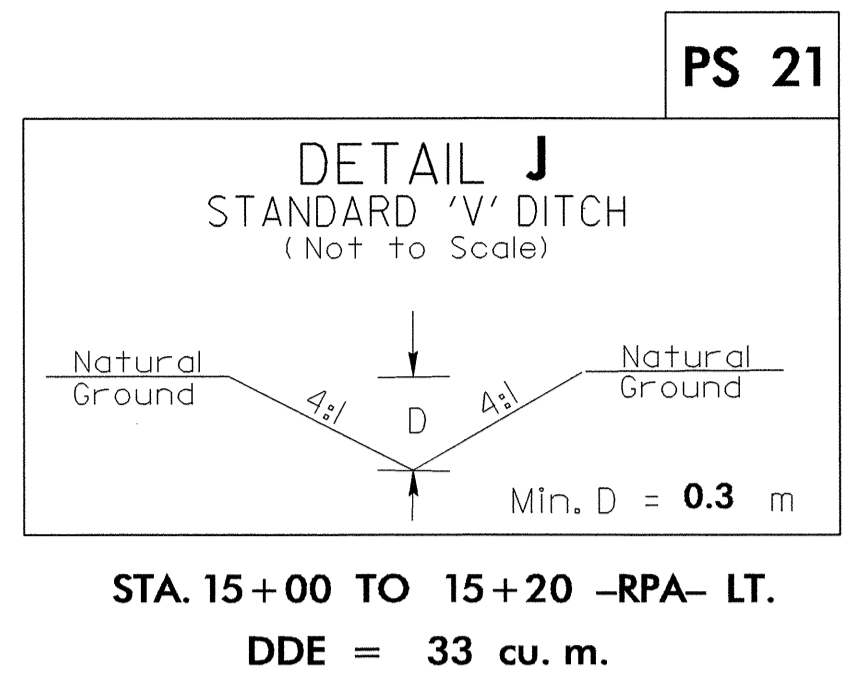
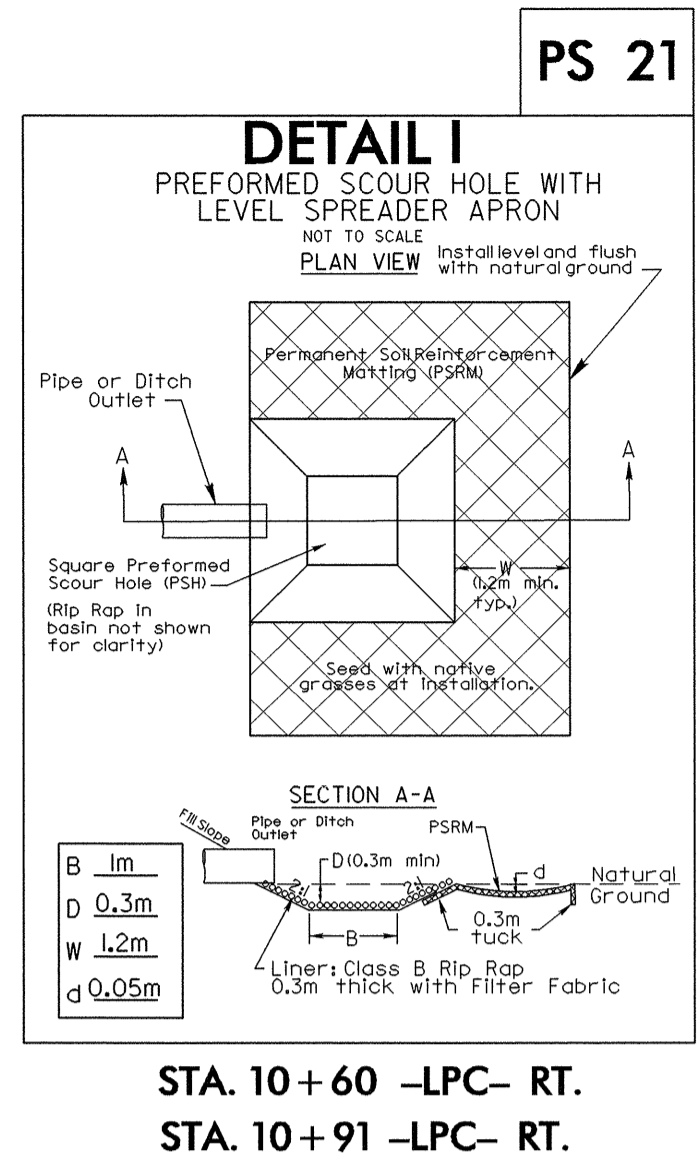
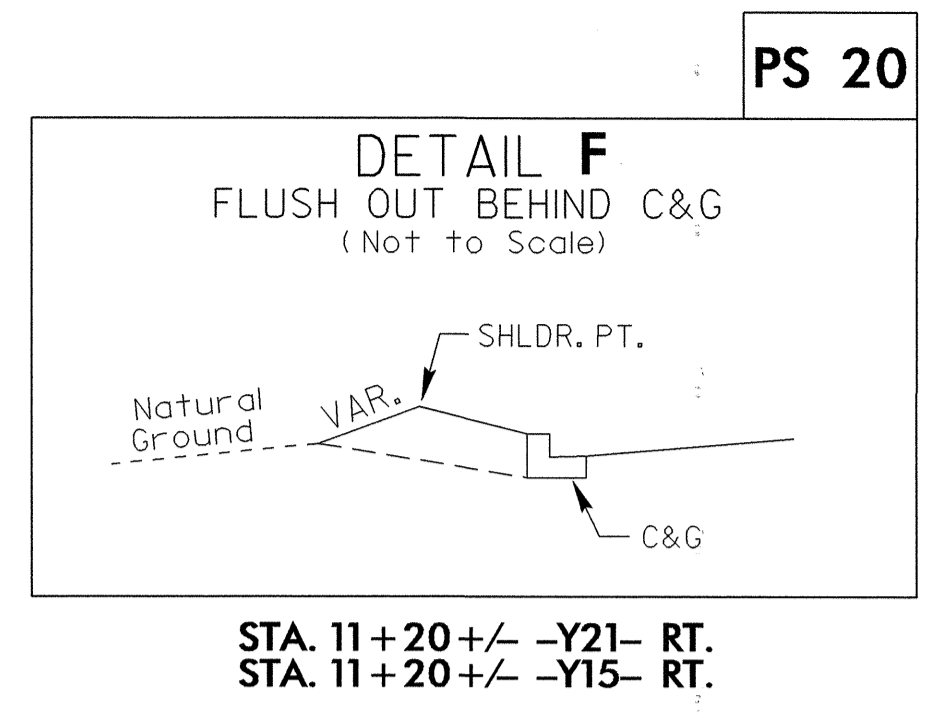
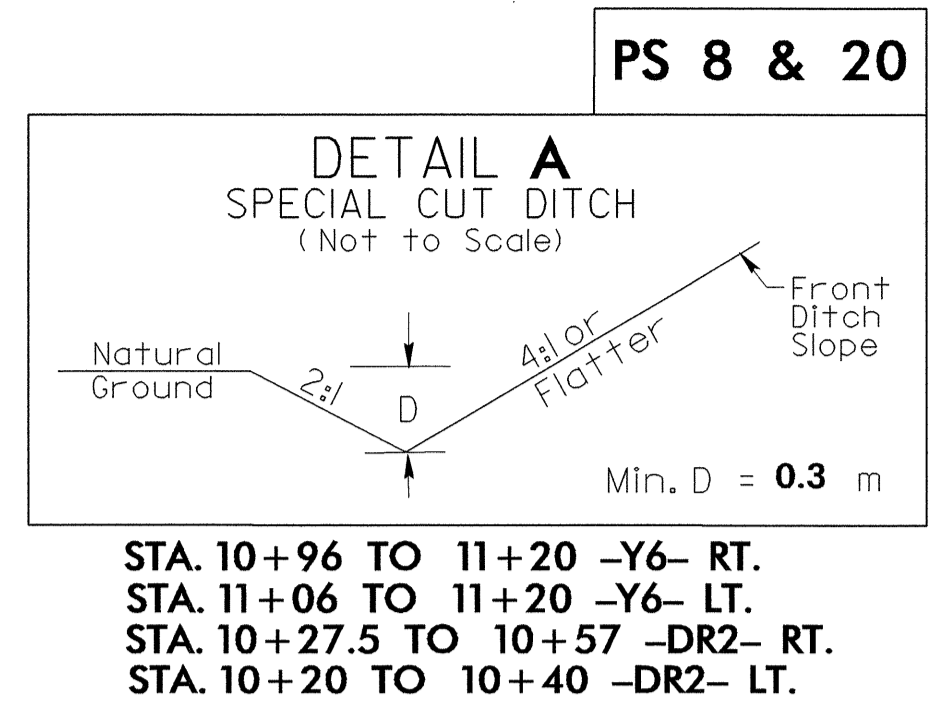

PROJECT REFERENCE NO. U-2717 SHEET NO. 2-E

ROADWAY DESIGN ENGINEER URBAN & PAVEMENT DESIGN ENGINEER

**METRIC**

SEAL 14493 SEAL 19860

PS = PLAN SHEET