



STATE OF NORTH CAROLINA
DEPARTMENT OF TRANSPORTATION

MICHAEL F. EASLEY
GOVERNOR

LYNDO TIPPETT
SECRETARY

August 1, 2007

U. S. Army Corps of Engineers
Regulatory Field Office
6508 Falls of Neuse Road
Raleigh, NC 27615

ATTN: Mr. Monte Matthews
NCDOT Coordinator

SUBJECT: **Clean Water Act Section 404 and 401 Individual Permit Applications** for the Proposed Visitor Center-Rest Station in Wilkes County. Federal Project No. NHS-421(32), WBS Element 36401.1.1, T.I.P. No. K-4703, Division 11.

REFERENCE: Nationwide Permit 23 Application, dated May 21, 2007.

Dear Mr. Matthews:

The North Carolina Department of Transportation (NCDOT) proposes to construct a new rest station in Wilkes County. The proposed project is located to the North of US 421 between NC Highway 115 and NC Highway 18.

The purpose of this letter is to revise the permit application submitted May 21, 2007, submit the final design, and to request approval for an USACE CWA Section 404 Individual Permit and a Section 401 Water Quality Certification. Included in this application package are the following: (1) ENG Form 4345, (2) property owner address labels, (3) North Carolina Ecosystem Enhancement Program (EEP) acceptance letter, (4) permit drawings, (5) a set of half size plans, and (6) a copy of a letter from SHPO.

PROJECT SCHEDULE

For construction purposes, the proposed rest area will be constructed in one section. This project has a let date of November 20, 2007 and a review date of October 2, 2007.

Purpose and Need: The main purpose of the proposed project is to replace the old rest station bypassed by the construction on the new US 421.

Summary of Impacts: The proposed project is in the Yadkin River Basin, Hydrologic Unit 03040101. Impacts on jurisdictional areas from the proposed project consist of a total of 657 feet of stream impacts.

Summary of Mitigation:

The project has been designed to avoid and minimize impacts to jurisdictional areas throughout the NEPA and design processes. However, project impacts will necessitate compensatory mitigation for the unavoidable impacts. Detailed descriptions of these actions are presented in the mitigation portion of this application. The Ecosystem Enhancement Program (EEP) will provide compensatory mitigation for 576 feet of stream impacts. Mitigation is not proposed for 81 feet of stream impacts at Site 1A due to the lack of sufficient aquatic habitat as determined during a site visit with the agencies on July 5, 2007.

NEPA DOCUMENT STATUS

A Programmatic Categorical Exclusion (CE) was approved by the Federal Highway Administration (FHWA) on February 24, 2006 for K-4703. The PCE has been revised by NCDOT and was sent to FHWA for approval and signature. When the document is signed a copy will be sent to the regulatory agencies.

INDEPENDENT UTILITY

The subject project is in compliance with 23 CFR Part 771.111(f) which lists the Federal Highway Administration (FHWA) characteristics of independent utility of a project:

- (1) The project connects logical termini and is of sufficient length to address environmental matters on a broad scope;
- (2) The project is usable and a reasonable expenditure, even if no additional transportation improvements are made in the area;
- (3) The project does not restrict consideration of alternatives for other reasonably foreseeable transportation improvements.

ALTERNATIVES CONSIDERED

Two alternative sites were evaluated for this project, Site 2 and Site 3. Site 3 was chosen as the preferred alternative for the following reasons.

- Site #2 would not provide enough spacing to provide a safe weaving area between the on-ramp from NC 115 and the off-ramp to the rest area.
- Construction of the off-ramp for Site 2 would require filling of the pond.

RESOURCE STATUS

Wetlands:

No wetlands occur within the project area.

Streams:

Stream impacts occur at 4 sites. Impacts to streams occur within HUC 03040101 of the Yadkin River Basin. Table 1 is a list of surface water impacts including stream name, type of structure, amount of impacts, mitigation required, DWQ stream index number, and DWQ classification. No designated Outstanding Resource Waters (ORW), High Quality Waters (HQW), Water Supply I (WS-I), Water Supply II (WS-II) or 303(d)

waters occur within 1.0 miles of the project study area. No waters classified trout waters by the NC Wildlife Resources Commission will be impacted by this project.

Table 1 – K-4703 Surface Water Impacts

Site	Stream Name and Intermittent (I) or Perennial (P)	Structure/ Size Type	Permanent Impacts	Mitigation Required	DWQ Index number	DWQ Class
1	UT1A to Little Cub Creek(P)	48" CSP	115	115	12-41-1-(2)	C
1	UT1B to Little Cub Creek(I)	8" CSP	81	0	12-41-1-(2)	C
2	UT2 to Little Cub Creek(P)	8" to 36" CSP	278	278	12-41-1-(2)	C
3	UT3 to Little Cub Creek(P)	60	124	124	12-41-1-(2)	C
4	UT4 to Little Cub Creek(P)	42	59	59	12-41-1-(2)	C
Total			657	576		

STREAM IMPACT DESCRIPTIONS

A site by site description of wetland and stream impacts is included below. Design details are included on the attached permit drawings and half size plans.

Site 1: The construction of the acceleration lane will require the extension of the existing pipe with a 48-inch corrugated steel pipe. Extension of the pipe will result in approximately 115 feet of impacts to UT 1A. The placement of an 8-inch corrugated steel pipe will also result in 81 feet of stream impacts to UT 1B. Impacts to UT 1B were determined to not require mitigation during the site visit with Monte Matthews of the USACE and Sue Homewood of DWQ on July 5, 2007.

A design that included using a drop inlet box to reduce impacts was evaluated for this site. However, due to two sharp bends in the existing channel, the determination was made that this design would erode the stream banks and would become a long-term maintenance problem.

Site 2: The construction of the exit ramp will require the placement of an 8-inch corrugated steel pipe that will increase in size to a 36-inch corrugated steel pipe in UT 2. Stream impacts will total approximately 278 feet.

Site 3: The construction of the deceleration lane will require the extension of the existing pipe with a 60-inch corrugated metal pipe. Extension of the pipe will result in approximately 124 feet of stream impacts to UT 3. The existing channel makes two sharp bends; therefore the bends will be removed to prevent erosion of the stream banks. NCDOT also proposes to install a constructed riffle, cross vane, rock seal, and natural rock energy dissipator to prevent any erosion of the stream banks downstream of the pipe outlet.

Site 4: The construction of the deceleration lane will require the extension of the existing 42-inch corrugated metal pipe and will result in approximately 59 feet of stream impacts to UT 4. The existing pipe at this site is perched. A riprap protection outlet pad will be used at this site to protect the stream banks.

FEDERALLY-PROTECTED SPECIES

Plants and animals with federal classifications of Endangered, Threatened, Proposed Endangered, and Proposed Threatened are protected under provisions of Section 7 and Section 9 of the Endangered Species Act of 1973, as amended. As of May 10, 2007, the Fish and Wildlife Service (FWS) lists one federally protected species for Wilkes County, the bog turtle. No biological conclusion is required for the bog turtle because it is listed as threatened due to similarity of appearance.

CULTURAL RESOURCES

Historic Architecture:

There are no structures over 50 years of age within the study area; therefore the project would not impact any historic properties.

Archaeology:

An archaeology survey was conducted for the project and no archaeological sites were identified during this survey. The SHPO concurred that the project would have no impact on any archaeology sites in the attached letter dated March 2006.

FEMA COMPLIANCE

This project will have no impacts on the 100-year floodplain.

UTILITY IMPACTS

There will be no proposed impacts to Waters of the U.S. due to utility construction.

ESSENTIAL FISH HABITAT

The project will not have any impacts on any essential fish habitat.

MITIGATION OPTIONS

The NCDOT is committed to incorporating all reasonable and practicable design features to avoid and minimize jurisdictional impacts, and to provide full compensatory mitigation of all remaining, unavoidable jurisdictional impacts. Avoidance measures were taken during the planning and NEPA compliance stages; minimization measures were incorporated as part of the project design.

Avoidance:

Avoidance has been employed to the maximum extent practical. All wetland areas not affected by the project will be protected from unnecessary encroachment.

General avoidance measures incorporated into the project design

- No Staging of construction equipment or storage of construction supplies will be allowed in wetlands or near surface waters.
- No borrow or waste areas will be located in wetland areas without a permit from the USACE.

Minimization:

Minimization has been employed in the project area to the maximum extent practical. Reduction of fill-slopes at stream/wetland crossings and the selection of alternatives that

will minimize wetland impacts will reduce unnecessary wetland takings.

Project Wide Minimization Measures

- Use of 2:1 side slopes in jurisdictional areas.
- Strict adherence to the procedures contained in Best Management Practices for Protection of Surface Waters, as well as NC Department of Environment and Natural Resources (NCDENR), Division of Land Resources, Land Quality Section's *North Carolina Erosion and Sediment Control Planning and Design Manual* will aid in avoiding and minimizing impacts to water resources and aquatic communities.
- No Erosion control structures will be placed in waters of the U.S.
- Clearing and grubbing activities will be minimized to reduce impacts to riparian buffers.

Site Specific Minimization Measures

- The original design for extending the perched pipe at Site 4 that included a rock energy dissipator, constructed riffle, cross vane, and rock seal has been revised. The design at Site 4 was revised to include a drop inlet box, reducing impacts by 59 feet.

Cost Prohibitive Avoidance and Minimization

To avoid and minimize impacts at Sites 1, 3 and 4, construction of a rock retaining wall or using rock plating with 1:1.5 side slopes on the acceleration and deceleration lanes was evaluated during the design stage of this project. Cost estimates for using rock plating ranged from \$273,000 to \$364,000. Cost estimates for a rock retaining wall were approximately \$1,335,000. Both options were determined to be cost prohibitive.

Compensatory Mitigation:

The construction of the K-4703 will result in 576 ft of stream impacts that will require mitigation within the Yadkin River Basin at a ratio of 1:1, as determined by Monte Matthews of the USACE during the site visit on July 5, 2007.

Based upon the agreements stipulated in the "Memorandum of Agreement Among the North Carolina Department of Environment and Natural Resources, the North Carolina Department of Transportation, and the U.S. Army Corps of Engineers, Wilmington District" (MOA), it is understood that the North Carolina Department of Environment and Natural Resources Ecosystem Enhancement Program (EEP), will assume responsibility for satisfying the federal Clean Water Act compensatory mitigation requirements for NCDOT projects.

The offsetting mitigation will be derived from an inventory of assets already in existence within the same 8-digit cataloguing unit. The Department has avoided and minimized impacts to jurisdictional resources to the greatest extent possible as described above. The remaining, unavoidable impacts to 576 feet of jurisdictional streams will be offset by compensatory mitigation provided by the EEP program as noted in the enclosed EEP confirmation letter.

SUMMARY

Section 404 Permit: Application is hereby made for a Department of the Army Section

404 Individual Permit for the above-described activities for the proposed TIP project K-4703. A copy of this permit application will be posted on the NCDOT website at: <http://www.ncdot.org/doh/preconstruct/pe/neu/permit.html>. NCDOT requests a 15-day public notice period for this project.

Section 401 Permit: Application is hereby made for a 401 Water Quality Certification the DWQ for the above-described activities.

Thank you for your assistance with this project. If you have any questions or need any additional information about this project, please contact Brett Feulner at (919) 715-1488.

Sincerely,



for

Greg Thorpe, P.E., Environmental Management Director
Project Development and Environmental Analysis Branch

GT/bmf

cc: w/attachment

Mr. John Hennessy, NCDWQ (5 Copies)

Ms. Marla Chambers, NCWRC

Mr. Victor Barbour, P.E. Project Services

Dr. David Chang, P.E., Hydraulics

Mr. Michael Pettyjohn, P.E. Division 11 Engineer

Mr. Heath Slaughter, Div 11 DEO

Ms. Marella Buncick, USFWS

Mr. Mark Staley, Roadside Environmental

Mr. Greg Perfetti, P.E., Structure Design

w/o attachment

Mr. Art McMillan, P.E., Highway Design

Mr. Majed Alghandour, P. E., Prog. and TIP

Mr. Ryan White, E.I.T., PDEA

Mr. Todd Jones, NCDOT External Audit Branch

Mr. Jay Bennett, P.E., Roadway Design

Mr. Scott McLendon, USACE, Wilmington

Ms. Beth Harmon, EEP

**APPLICATION FOR DEPARTMENT OF THE ARMY PERMIT
(33 CFR 325)**

OMB APPROVAL NO. 0710-003

Public reporting burden for this collection of information is estimated to average 5 hours per response, including the time for reviewing instructions, Searching existing data sources, gathering and maintaining the data needed, and completing and reviewing the collection of information. Send comments regarding this burden estimate or any other aspect of this collection of information, including suggestions for reducing this burden, to Department of Defense, Washington Headquarters Service Directorate of Information Operations and Reports, 1215 Jefferson Davis Highway, Suite 1204, Arlington VA 22202-4302; and to the Office of Management and Budget, Paperwork Reduction Project (0710-003), Washington, DC 20503. Please **DO NOT RETURN** your form to either of those addresses. Completed applications must be submitted to the District Engineer having jurisdiction over the location of the proposed activity.

PRIVACY ACT STATEMENT

Authority: 33 USC 401, Section 10; 1413, Section 404. Principal Purpose: These laws require permits authorizing activities in, or affecting, navigable waters of the United States; the discharge of dredged or fill material into waters of the United States, and the transportation of dredged material for the purpose of dumping it into ocean waters. Routine uses: Information provided on this form will be used in evaluating the application for a permit. Disclosure: Disclosure of requested information is voluntary. If information is not provided, however, the permit application cannot be processed nor can a permit be issued.

One set of original drawings or good reproducible copies which show the location and character of the proposed activity must be attached to this application (see sample drawings and instructions) and be submitted to the District Engineer having jurisdiction over the proposed activity. An application that is not completed in full will be returned.

(ITEMS 1 THRU 4 TO BE FILLED BY THE CORPS)

1. APPLICATION NO.	2. FIELD OFFICE CODE	3. DATE RECEIVED	4. DATE APPLICATION COMPLETED
--------------------	----------------------	------------------	-------------------------------

(ITEMS BELOW TO BE FILLED BY APPLICANT)

5. APPLICANT'S NAME NCDOT	8. AUTHORIZED AGENT'S NAME & TITLE (an agent is not required)
6. APPLICANT'S ADDRESS 1598 Mail Service Center Raleigh, NC 27699	9. AGENT'S ADDRESS
7. APPLICANT'S PHONE NUMBERS WITH AREA CODE a. Residence b. Business 919-715-1488	10. AGENT'S PHONE NUMBERS WITH AREA CODE a. Residence b. Business

11. STATEMENT OF AUTHORIZATION

I hereby authorize _____ to act in my behalf as my agent in the processing of this application and to furnish, upon request, supplemental information in support of this permit application.

APPLICANT'S SIGNATURE

DATE

NAME, LOCATION, AND DESCRIPTION OF PROJECT OR ACTIVITY

12. PROJECT NAME OR TITLE (see instructions) K-4703- US 421 Rest Station	
13. NAME OF WATERBODY, IF KNOWN (if applicable) UTs to Little Cub Creek	14. PROJECT STREET ADDRESS (if applicable)
15. LOCATION OF PROJECT Wilkes COUNTY NC STATE	
16. OTHER LOCATION DESCRIPTIONS, IF KNOWN (see instructions)	

17. DIRECTIONS TO THE SITE

The project is located north of US 421 between NC Highway 115 and NC Highway 18

18. NATURE OF ACTIVITY (Description of project, include all features)

Construction of a new rest area

19. PROJECT PURPOSE (Describe the reason or purpose of the project, see instructions)

To replace the one closed with the construction of New US 421

USE BLOCKS 20-22 IF DREDGED AND/OR FILL MATERIAL IS TO BE DISCHARGED

20. REASON(S) FOR DISCHARGE

Extension of three existing pipes and placement of one new pipe for the construction of acceleration and deceleration lanes to access the proposed rest area.

21. TYPE(S) OF MATERIAL BEING DISCHARGED AND THE AMOUNT OF EACH TYPE IN CUBIC YARDS

Corrugated steel pipes

22. SURFACE AREA IN ACRES OF WETLANDS OR OTHER WATERS FILLED (see instructions)

657 feet of stream impacts

23. IS ANY PORTION OF THE WORK ALREADY COMPLETE? YES NO IF YES, DESCRIBE THE WORK

24. ADDRESSES OF ADJOINING PROPERTY OWNERS, LESSEES, ETC. WHOSE PROPERTY ADJOINS THE WATERBODY (If more than can be entered here, please attach a supplemental list)

Lester Wilfong, Jr
252 E Edgewood Mill Road
Wilkesboro, NC 28697

Bessie Harris, et al
C/O Mary Smith
675 Camp Joe Harris Rd
N. Wilkesboro, NC 28659

James Wilson Harris
1195 Camp Joe Harris Rd.
N. Wilkesboro, NC 28659

25. LIST OF OTHER CERTIFICATIONS OR APPROVALS/DENIALS RECEIVED FROM OTHER FEDERAL, STATE, OR LOCAL AGENCIES FOR WORK DESCRIBED IN THIS APPLICATION

AGENCY	TYPE APPROVAL*	IDENTIFICATION NUMBER	DATE APPLIED	DATE APPROVED	DATE DENIED
--------	----------------	-----------------------	--------------	---------------	-------------

* Would include but is not restricted to zoning, building and flood plain permits.

26. Application is hereby made for a permit or permits to authorize the work described in this application. I certify that the information in this application is complete and accurate. I further certify that I possess the authority to undertake the work described herein or am acting as the duly authorized agent of the applicant.

SIGNATURE OF APPLICANT

DATE

SIGNATURE OF AGENT

DATE

The application must be signed by the person who desires to undertake the proposed activity (applicant) or it may be signed by a duly authorized agent if the statement in block 11 has been filled out and signed.

18 U.S.C. Section 1001 provides that: Whoever, in any manner within the jurisdiction of any department or agency of the United States knowingly and willfully falsifies, conceals, or covers up any trick, scheme, or disguises a material fact or makes any false, fictitious, or fraudulent statements or representations or makes or uses any false writing or document knowing same to contain any false, fictitious or fraudulent statements or entry, shall be fined not more than \$10,000 or imprisoned not more than five years or both.

Lester Wilfong, Jr.
252 E. Edgewood Mill Road
Wilkesboro, NC 28697

James Wilson Harris
1195 Camp Joe Harris Road
N. Wilkesboro, NC 28659

Bessie Harris, et al
C/O Mary Smith
675 Camp Joe Harris Rd.
N. Wilkesbor, NC 28659



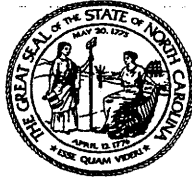

North Carolina Department of Cultural Resources
State Historic Preservation Office

Peter B. Sandbeck, Administrator

Michael F. Easley, Governor
Lisbeth C. Evans, Secretary
Jeffrey J. Crow, Deputy Secretary

Office of Archives and History
Division of Historical Resources
David Brook, Director

March 30, 2006

MEMORANDUM

TO: Greg Thorpe, Ph.D., Director
Project Development and Environmental Analysis Branch
NCDOT Division of Highways

FROM: Peter Sandbeck *for Peter Sandbeck*

SUBJECT: Categorical Exclusion for New Rest Area to Replace Bypassed Rest Area on Old US 421,
K-4703, Wilkes County, ER 05-0302

Thank you for your letter of March 3, 2006, transmitting the Categorical Exclusion (CE) for the above project. We believe the CE adequately addresses our concerns for historic resources.

The above comments are made pursuant to Section 106 of the National Historic Preservation Act and the Advisory Council on Historic Preservation's Regulations for Compliance with Section 106 codified at 36 CFR Part 800.

Thank you for your cooperation and consideration. If you have questions concerning the above comment, please contact Renee Gledhill-Earley, environmental review coordinator, at 919/733-4763. In all future communication concerning this project, please cite the above-referenced tracking number.

cc: Mary Pope Furr, NCDOT
Matt Wilkerson, NCDOT

	Location	Mailing Address	Telephone/Fax
ADMINISTRATION	507 N. Blount Street, Raleigh NC	4617 Mail Service Center, Raleigh NC 27699-4617	(919)733-4763/733-8653
RESTORATION	515 N. Blount Street, Raleigh NC	4617 Mail Service Center, Raleigh NC 27699-4617	(919)733-6547/715-4801
SURVEY & PLANNING	515 N. Blount Street, Raleigh, NC	4617 Mail Service Center, Raleigh NC 27699-4617	(919)733-6545/715-4801

See Sheet 1-A For Index of Sheets
See Sheet 1-B For Conventional Symbols

STATE OF NORTH CAROLINA
DIVISION OF HIGHWAYS

WILKES COUNTY

LOCATION: NEW REST AREA - NORTHBOUND US 421
WEST OF NC 115

TYPE OF WORK: GRADING, PAVING, AND DRAINAGE

STATE	STATE PROJECT REFERENCE NO.	SHEET NO.	TOTAL SHEETS
N.C.	K-4703	1	
STATE PROJ. NO.	F.A. PROJ. NO.	DESCRIPTION	
36401.1.1	NHS-421(32)	PE	

**WETLAND PERMIT
DRAWINGS 01/09/07**

TIP PROJECT: K-4703

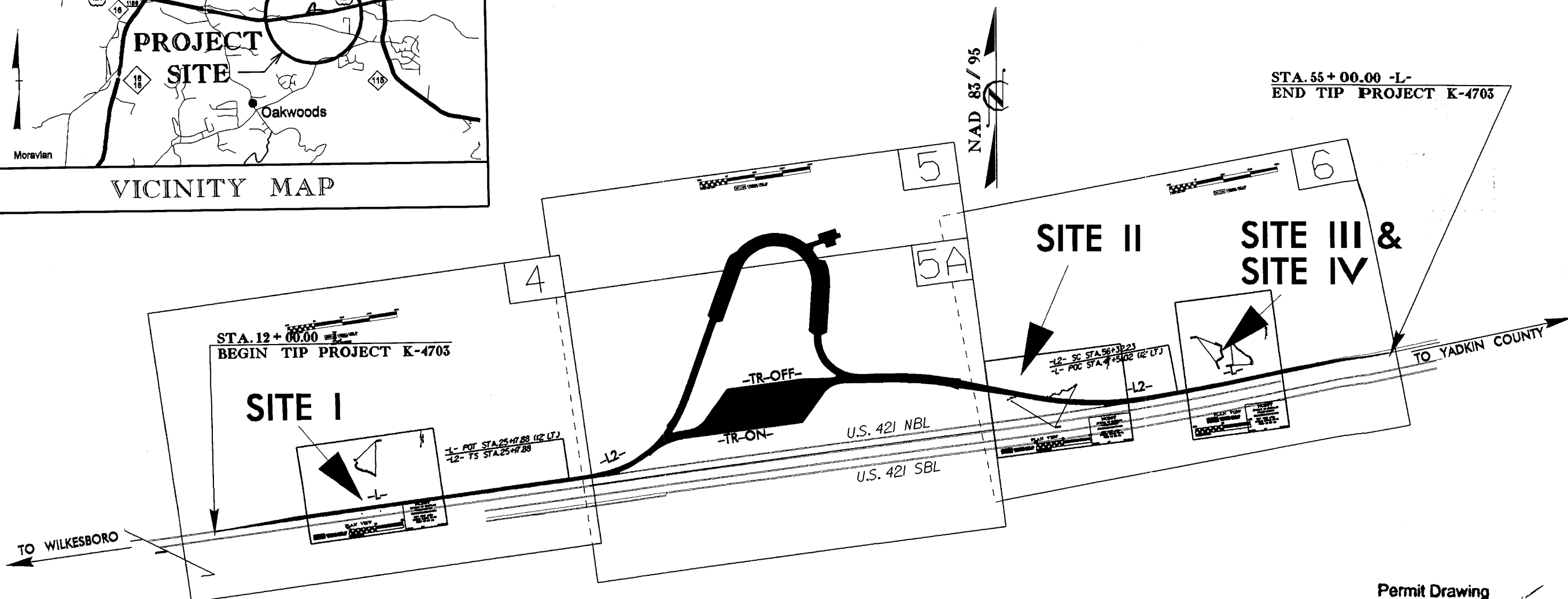
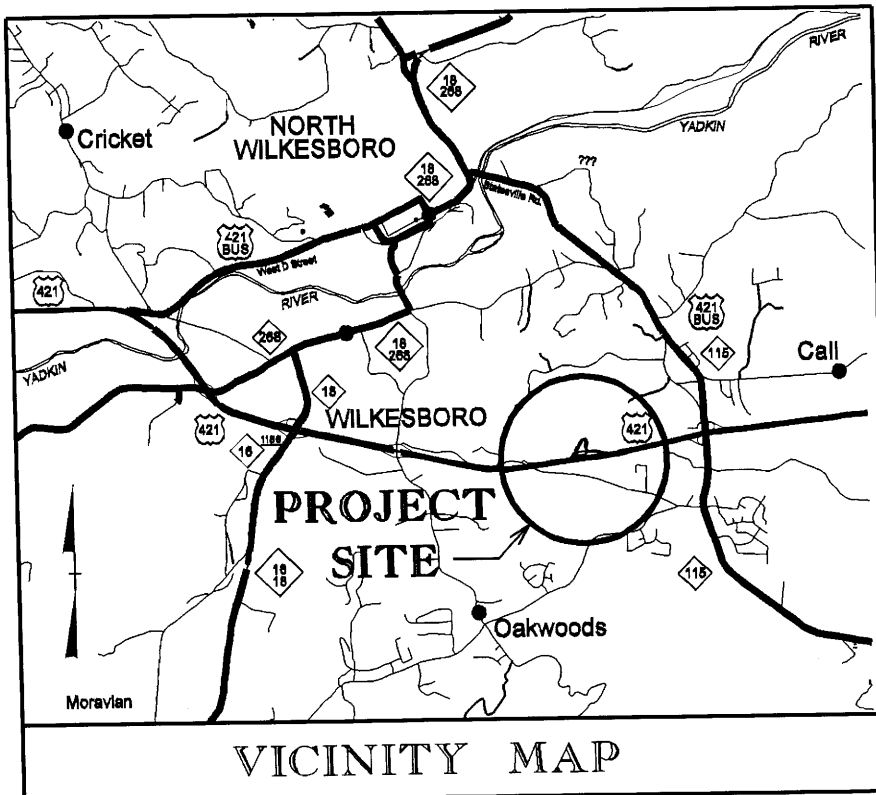

THIS PROJECT IS NOT WITHIN ANY MUNICIPAL BOUNDARIES
NOTE: CLEARING ON THIS PROJECT SHOULD BE PERFORMED TO THE LIMITS ESTABLISHED BY METHOD _____

Permit Drawing
Sheet 1 of 15

09-APR-2007 13:52
P:\highways\p1000\k4703\rdly_tsh.dgn

CONTRACT: C201679

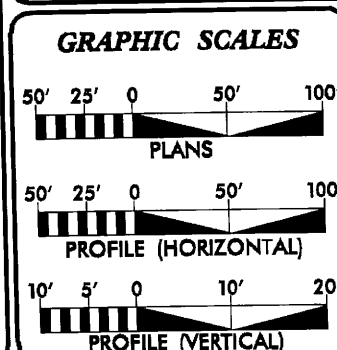

DESIGN DATA

ADT 2007 =	1000
ADT 2030 =	1500
DHV =	11 %
D =	100 %
T =	32 % *
V =	20MPH
FUNC. CLASS. =	REST AREA
* TTST 28%	DUAL 4%

PROJECT LENGTH

LENGTH ROADWAY TIP PROJECT K-4703 =	0.981 MILES
TOTAL LENGTH OF TIP PROJECT K-4703 =	0.981 MILES

Prepared in the Office of:
DIVISION OF HIGHWAYS
1000 Birch Ridge Dr.
Raleigh, NC 27610

2006 STANDARD SPECIFICATIONS	
RIGHT OF WAY DATE:	ROGER D. THOMAS, P.E. PROJECT ENGINEER
NA	
LETTING DATE:	MICHAEL W. LITTLE, P.E. PROJECT DESIGN ENGINEER
SEPTEMBER 18, 2007	

HYDRAULICS ENGINEER

SIGNATURE: _____ P.E.

ROADWAY DESIGN ENGINEER

SIGNATURE: _____ P.E.

PRELIMINARY PLANS
DO NOT USE FOR CONSTRUCTION

INCOMPLETE PLANS
DO NOT USE FOR B.B.K. ADJUSTMENTS

**DIVISION OF HIGHWAYS
STATE OF NORTH CAROLINA**

STATE HIGHWAY DESIGN ENGINEER

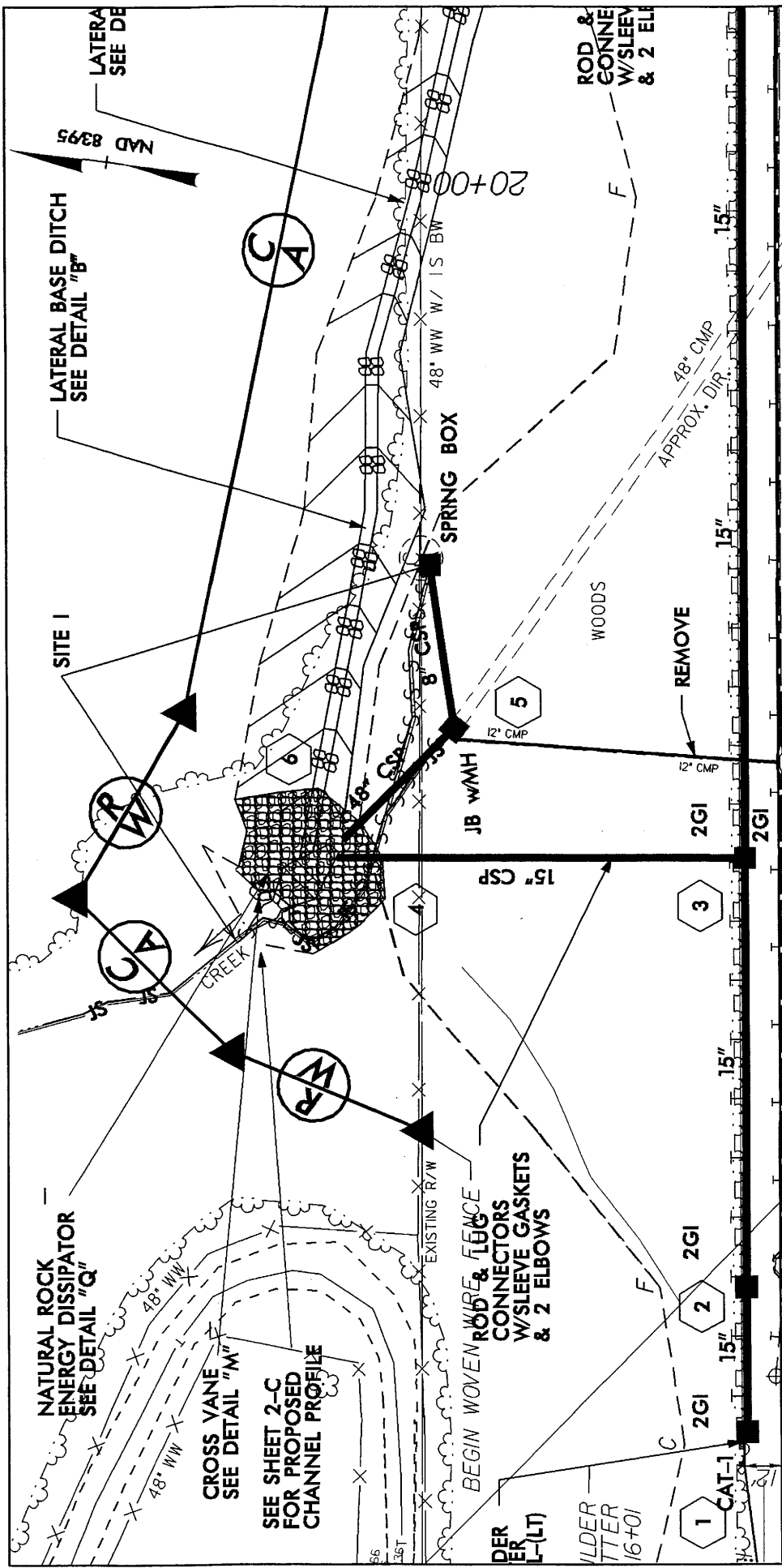

NCDOT
 DIVISION OF HIGHWAYS
 WILKES COUNTY
 PROJECT: 36-401.11 (K-4703)
 NEW REST AREA
 NORTH BOUND US 421
 WEST OF NC 115

REV. 05/21/07
 04/09/07

SHEET 2 OF 15

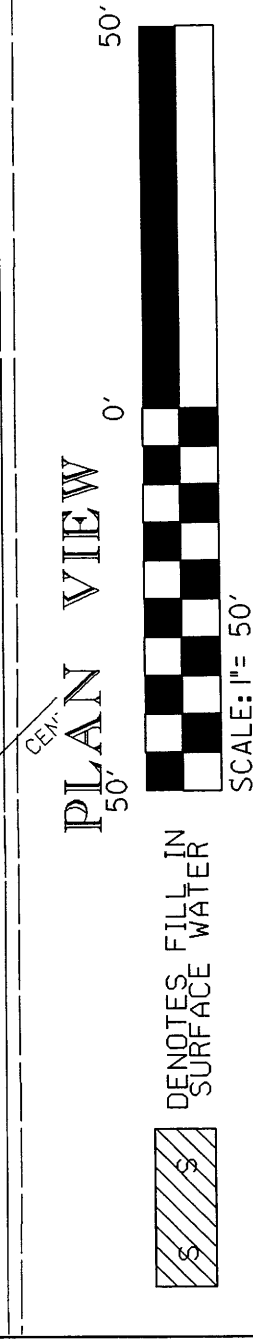

 DENOTES FILL IN SURFACE WATER
 SURFACE WATER

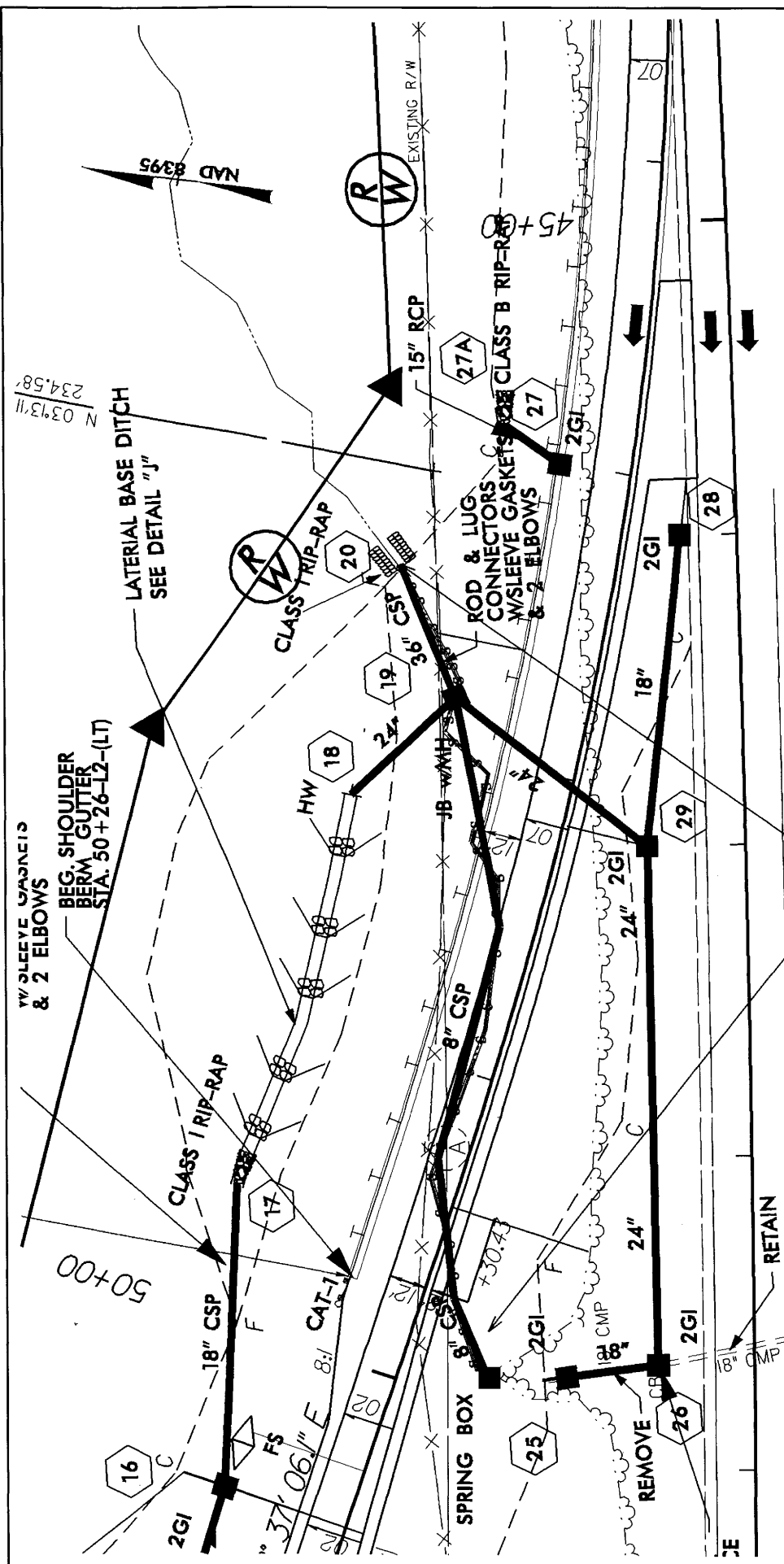

NCDOT
 DIVISION OF HIGHWAYS
 WILKES COUNTY
 PROJECT: 36-401.1.1 (K-4703)
 NEW REST AREA
 NORTH BOUND US 421
 WEST OF NC 115

SHEET 2 OF 15
 04/09/07

LATERAL BASE DITCH
 SEE DETAIL "J"

CLASS 1 RIP-RAP
 CLASS 2 RIP-RAP
 CLASS B RIP-RAP

1/2" SLEEVE ELBOWS & 2 ELBOWS
 BEG. SHOULDER BERM GUTTER STA. 50+26-L2-(LT)

15" RCP
 18" CSP
 24" CSP
 36" CSP
 8" CSP
 24" 2GI
 18" 2GI
 24" 2GI
 18" 2GI

ROD & LUG CONNECTORS W/SLEEVE GASKETS & 2 ELBOWS

SPRING BOX
 REMOVE
 RETAIN

18" CMP
 APPROX. DIR.

SITE II
 PLAN VIEW
 SCALE: 1" = 50'
 DENOTES FILL IN SURFACE WATER

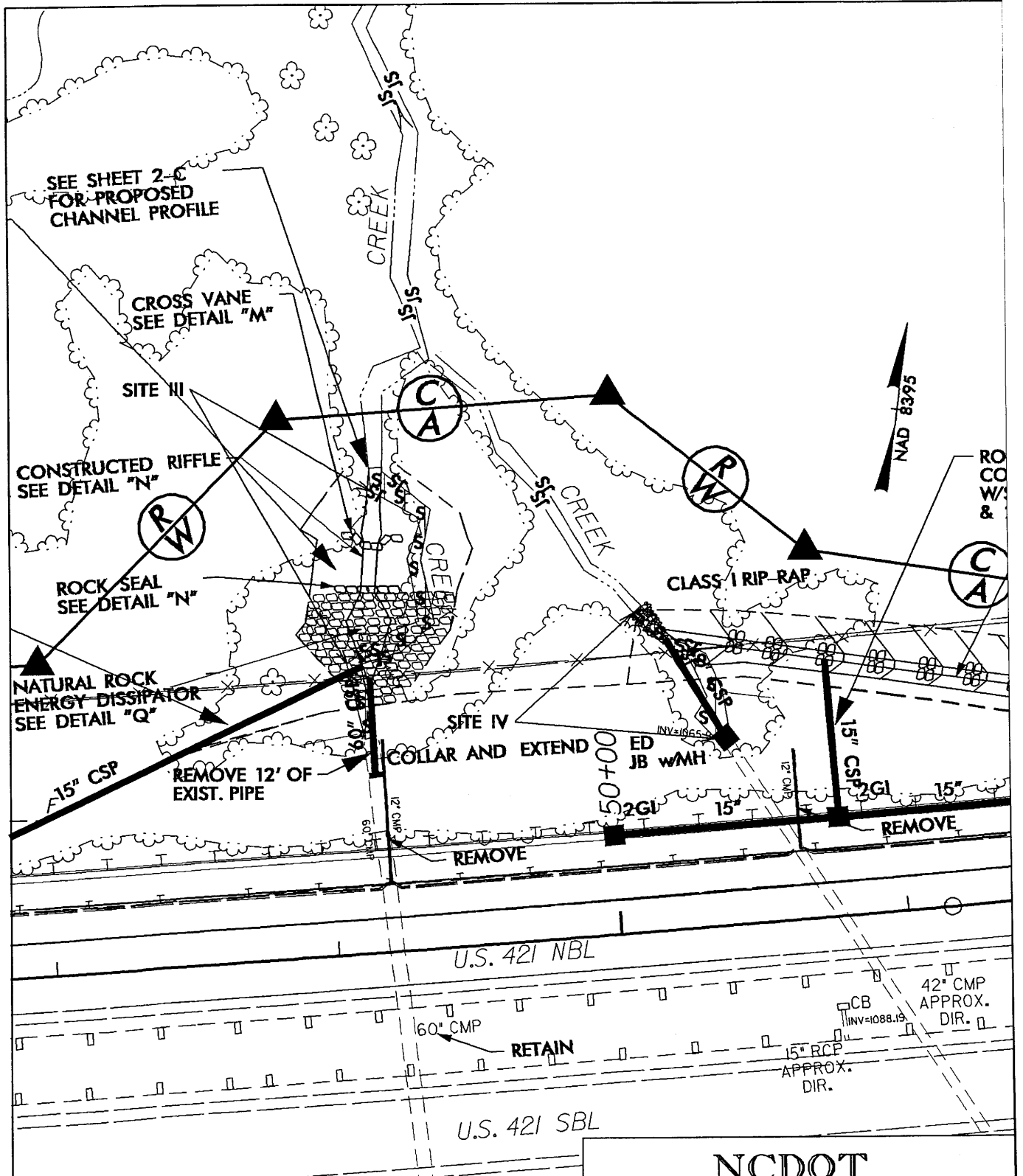

PLAN VIEW

 DENOTES FILL IN SURFACE WATER



SCALE: 1" = 50'

NCDOT
 DIVISION OF HIGHWAYS
 WILKES COUNTY
 PROJECT: 36401.1.1 (K-4703)
 NEW REST AREA
 NORTH BOUND US 421
 WEST OF NC 115

SHEET 4 OF 15

REV 7/16/07
 04/09/07

5/28/09

STREAM DESIGN FOR 48" CMP
-L- STA 10+93.73 TO 10+33.11 -R- STA 10+00
FOR PLAN VIEW SEE SHEET 4

STREAM DESIGN FOR 60" CMP
-L- STA 10+49.17 TO 10+22.72 -R- STA 10+00
FOR PLAN VIEW SEE SHEET 6

PROJECT REFERENCE NO. K-4703	SHEET NO. 2-C
ROADWAY DESIGN ENGINEER	HYDRAULICS ENGINEER
PRELIMINARY PLANS DO NOT USE FOR CONSTRUCTION	
INCOMPLETE PLANS DO NOT USE FOR R/W ACQUISITION	

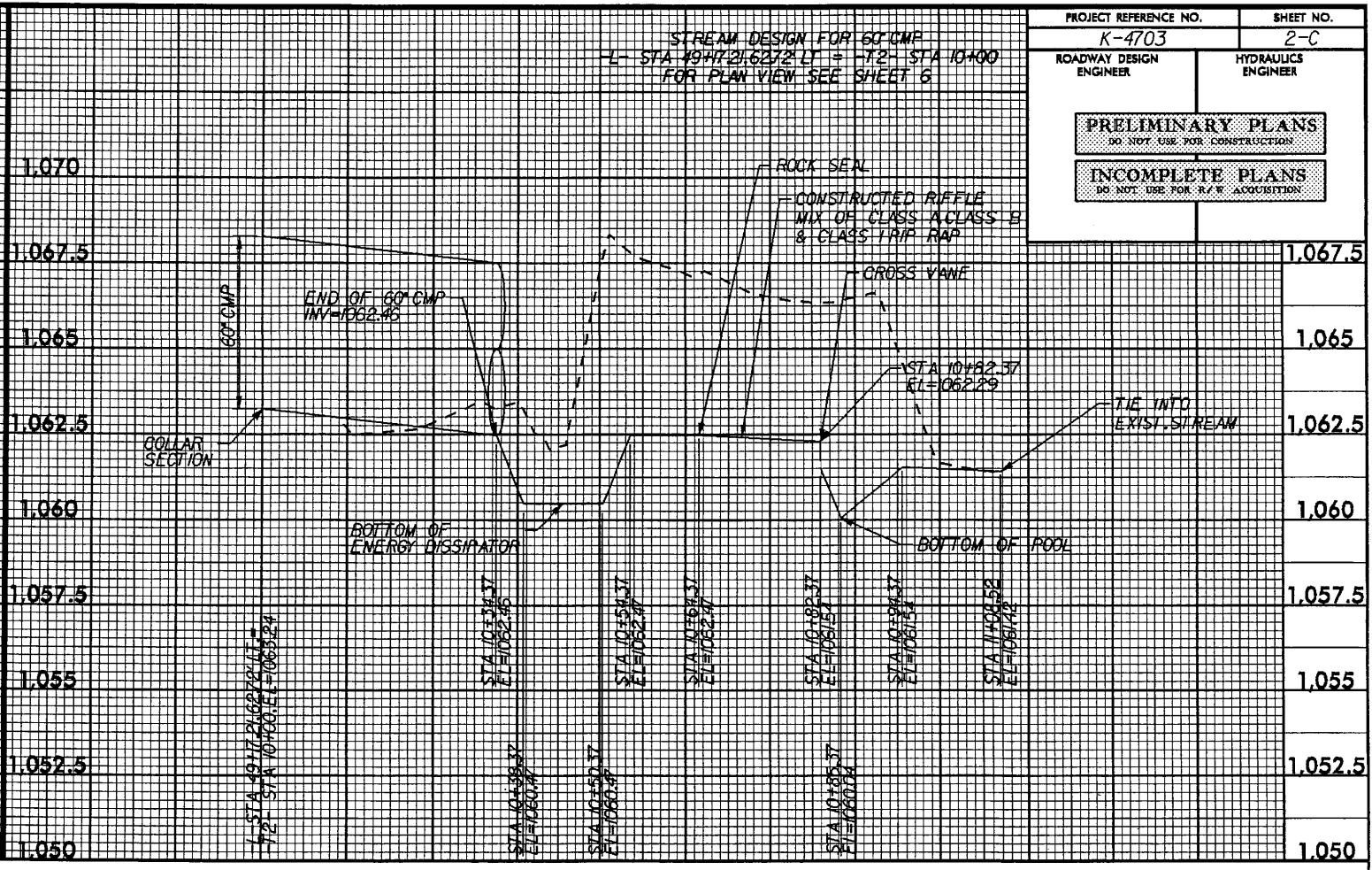
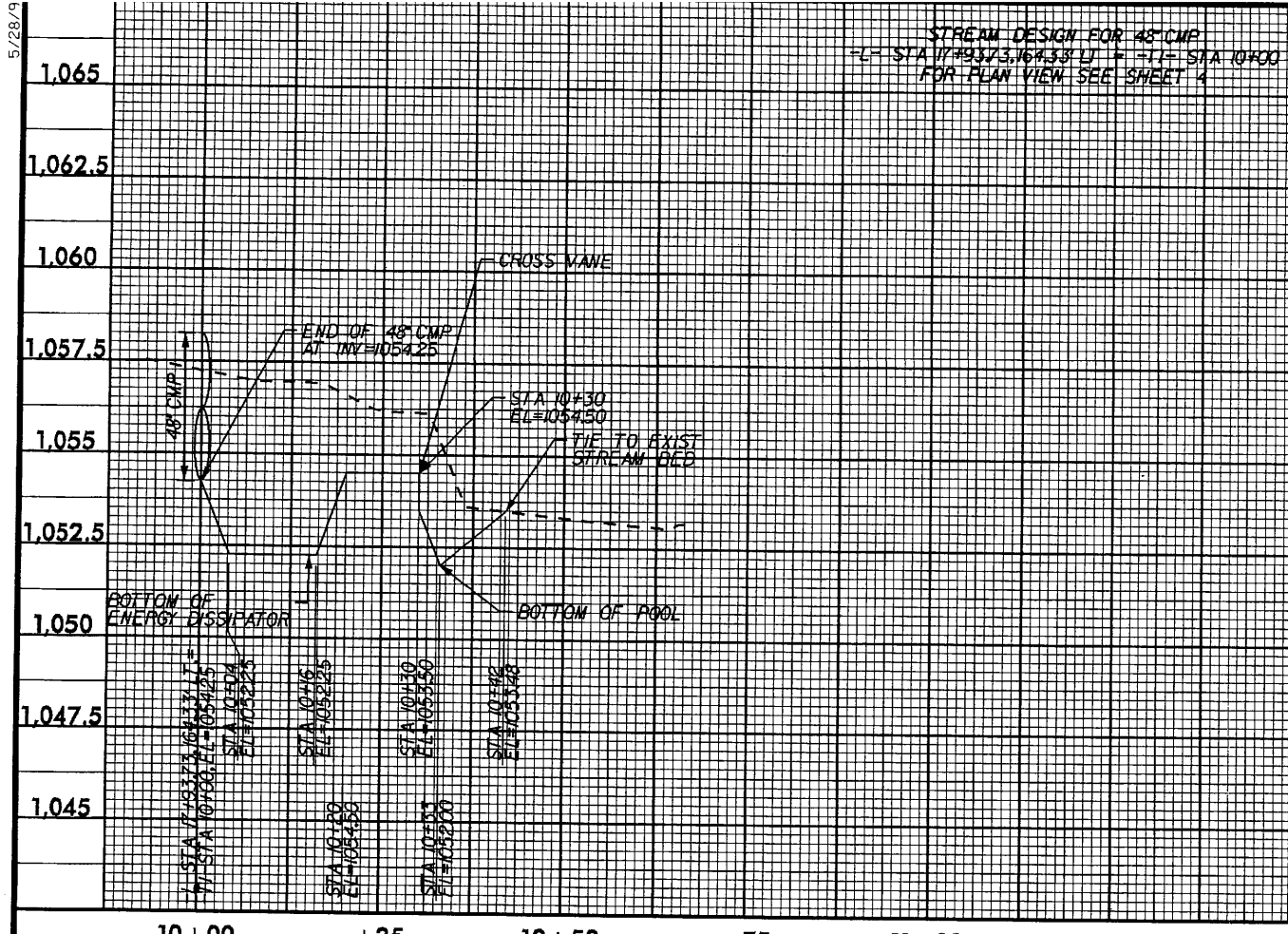

16-JUL-2007 14:39
r:\drainage\k4703\hydes\1_ditch_streams.dgn
11/2/2008

Permit Drawings
Sheet 5 of 15

VERTICAL: 1"=25'
HORIZONTAL: 1"=25'

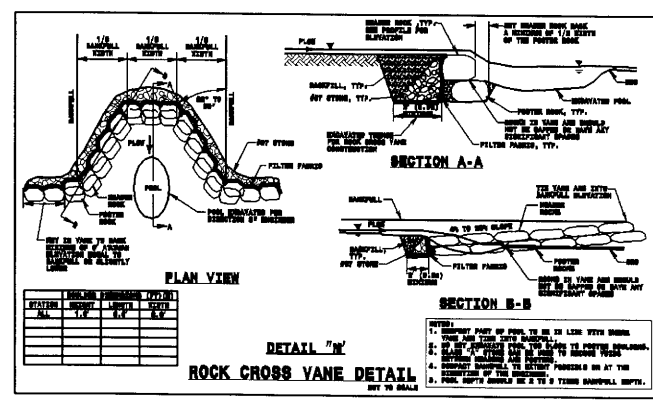
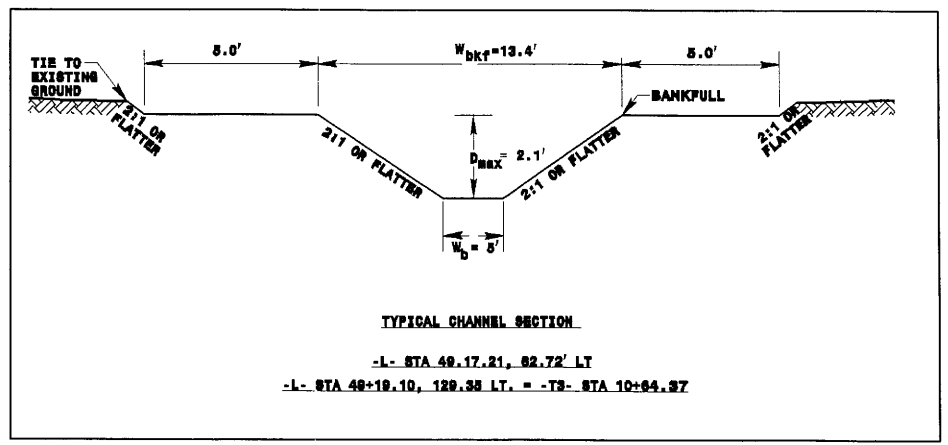
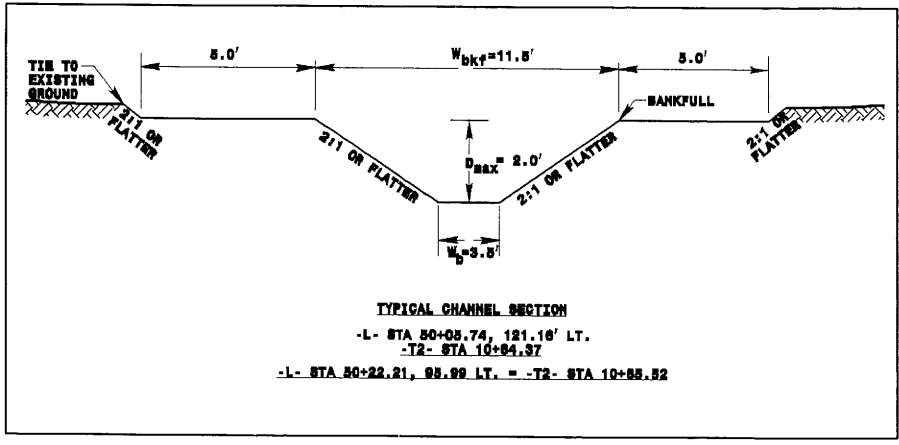
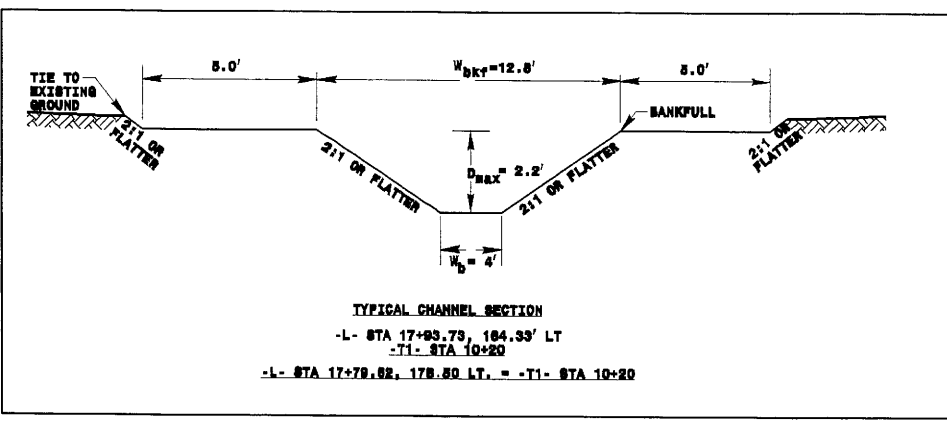
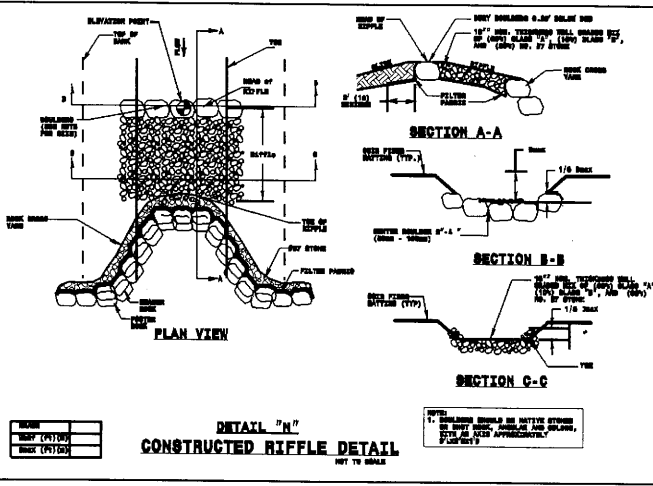
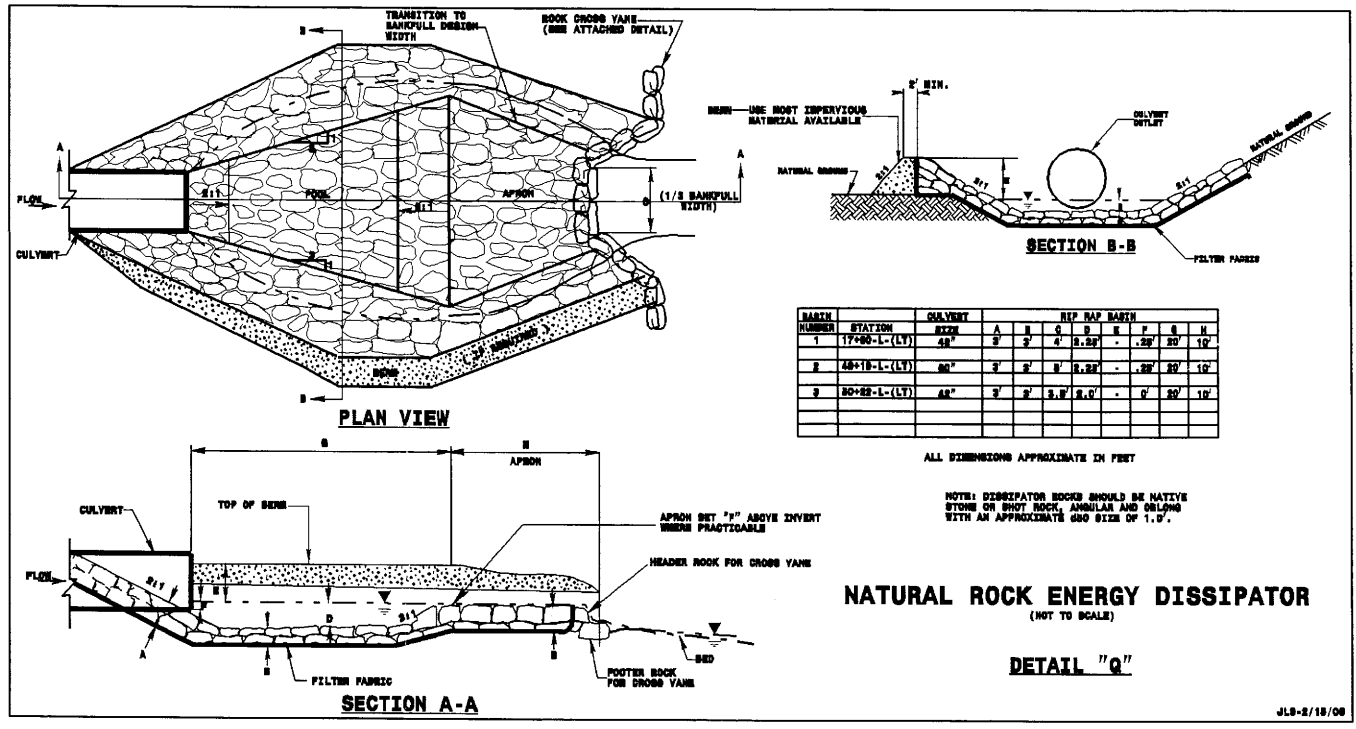
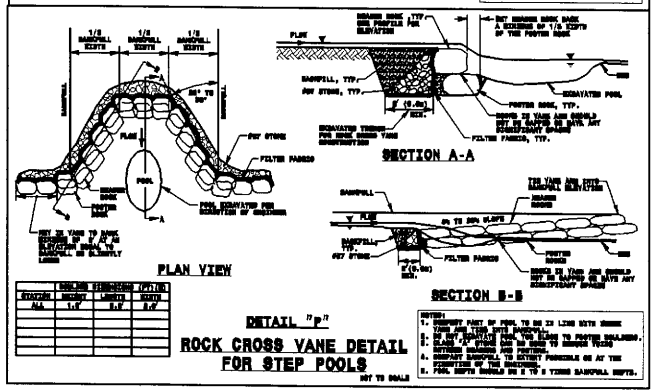
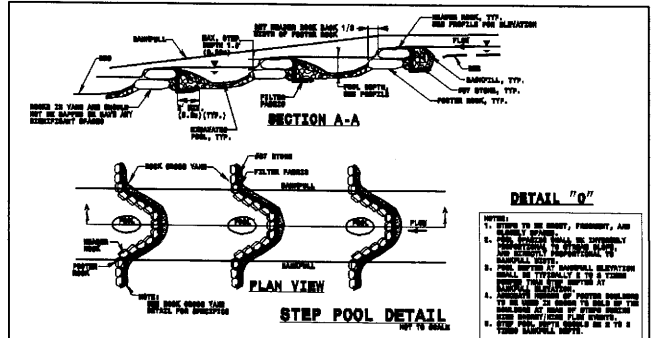

REVISIONS

09-APR-2007 13:41
r:\hydr-aulics\4703_hyd-det.dgn
medunnhoob AT HY212436

-L2- SPIRAL DATA
 Pts Sta 26+51.65
 Gs = 14' 19" 26.2"
 Ls = 200.00'
 LT = 133.77'
 ST = 67.07'

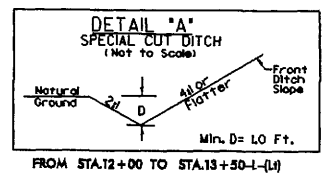

Sta. 18+00 - 23+00-L(-L)
 DA = 8.73 AC
 CW = 0.29'
 S = 2.44 @ 21 min. & R0 = 4.09'
 CS = 8.54 @ 8' Q10 = 9.87' ds
 R = 11.078' @ 24'
 AS = 0.25' @ 40' = 0.49'
 V2 = 4.17' @ 10' & V10 = 4.33' @ 10'
 Shear Stress = 2.57'

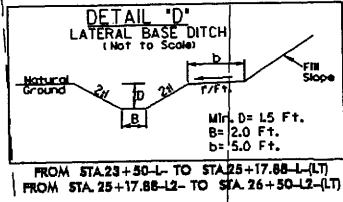
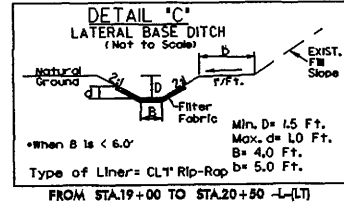
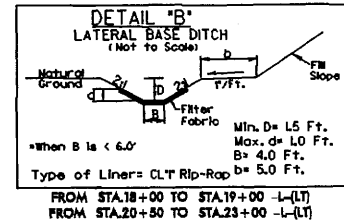

BEGIN PROJECT K-4703
 -L- STA.12+00.00

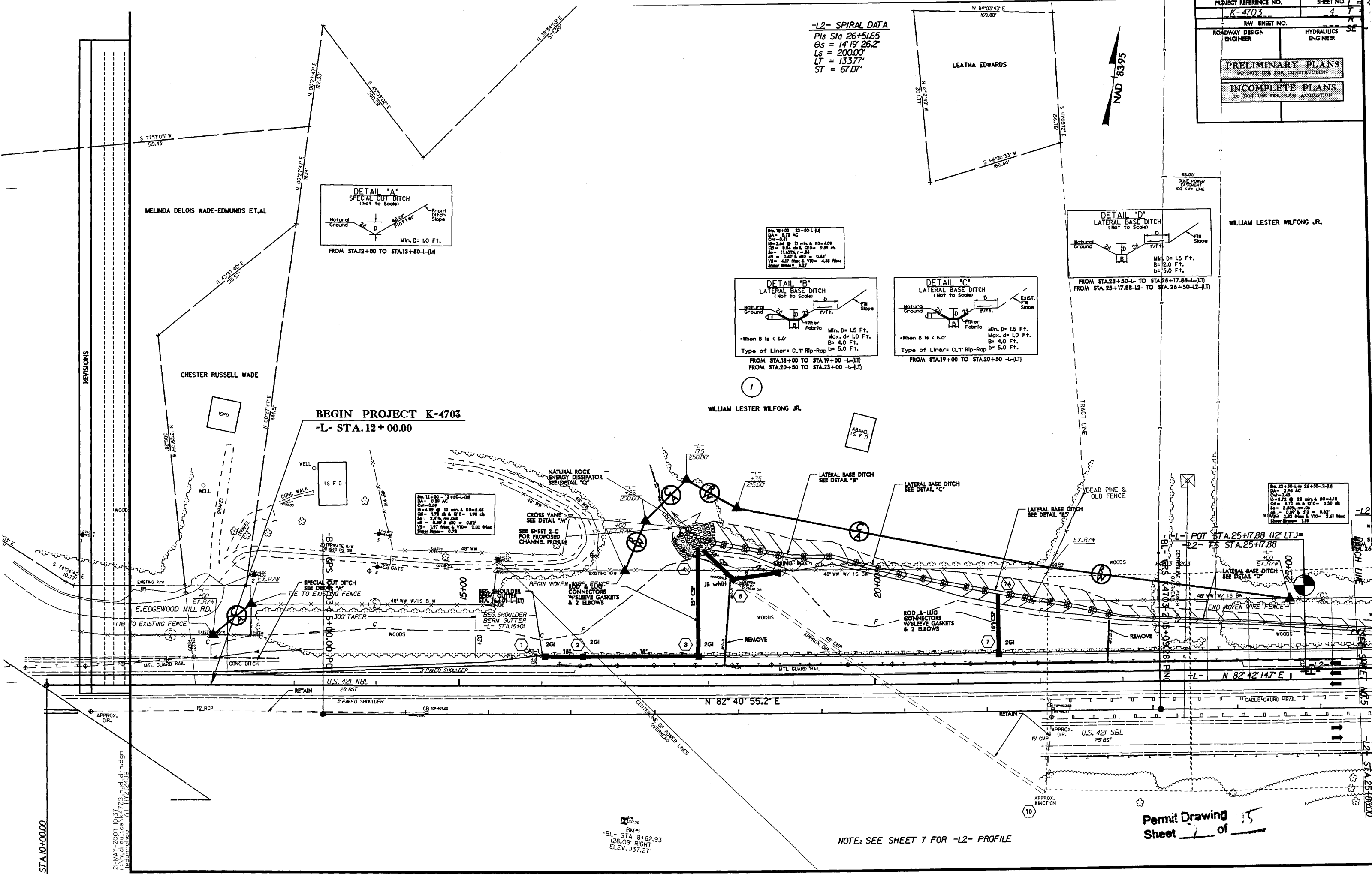

Sta. 12+00 - 13+50-L(-L)
 DA = 0.89 AC
 CW = 0.29'
 S = 4.89 @ 10 min. & R0 = 5.48'
 CS = 1.76 @ 8' Q10 = 1.90' ds
 R = 2.016' @ 24'
 AS = 0.20' @ 40' = 0.32'
 V2 = 1.97' @ 10' & V10 = 2.02' @ 10'
 Shear Stress = 0.73'

Sta. 22+50-L(-L) to 26+50-L2(-L2)
 DA = 3.93 AC
 CW = 0.43'
 S = 3.72 @ 20 min. & R0 = 4.18'
 CS = 4.72 @ 8' Q10 = 5.20' ds
 R = 3.820' @ 24'
 AS = 0.25' @ 40' = 0.49'
 V2 = 2.58' @ 10' & V10 = 2.61' @ 10'
 Shear Stress = 1.18'

BM#1
 -BL- STA 8+62.93
 128.09' RIGHT
 ELEV. 137.27'

NOTE: SEE SHEET 7 FOR -L2- PROFILE

Permit Drawing
 Sheet 1 of 5

STA.10+00.00

21-MAY-2007 10:37
 F:\hyd\autos\k4703_hyd_dfn.dgn
 melindewade AT HY212436

PROJECT REFERENCE NO.	SHEET NO. / TOTAL
K-4703	4 / 7
R/W SHEET NO.	R
ROADWAY DESIGN ENGINEER	HYDRAULICS ENGINEER
PRELIMINARY PLANS DO NOT USE FOR CONSTRUCTION	
INCOMPLETE PLANS DO NOT USE FOR R/W ACQUISITION	

-L2- SPIRAL DATA
 PIs Sta 26+51.65
 Os = 14'19" 26.2'
 Ls = 200.00'
 LT = 133.77'
 ST = 67.07'

NAD 8395

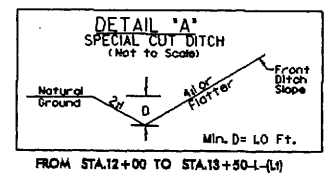

Sta. 18+00 - 23+00-L-04
 DA = 0.73 AC
 Cs = 0.41
 Ls = 24.00' 21 min. & 10" = 4.29'
 Os = 8.84' @ 30' & 300' = 9.39' @ 30'
 Ls = 11.4379' = 0.41'
 Os = 0.21' @ 30' = 0.41'
 Ls = 4.17' Max. & 170' = 4.23' Max.
 Slope = 3.37'

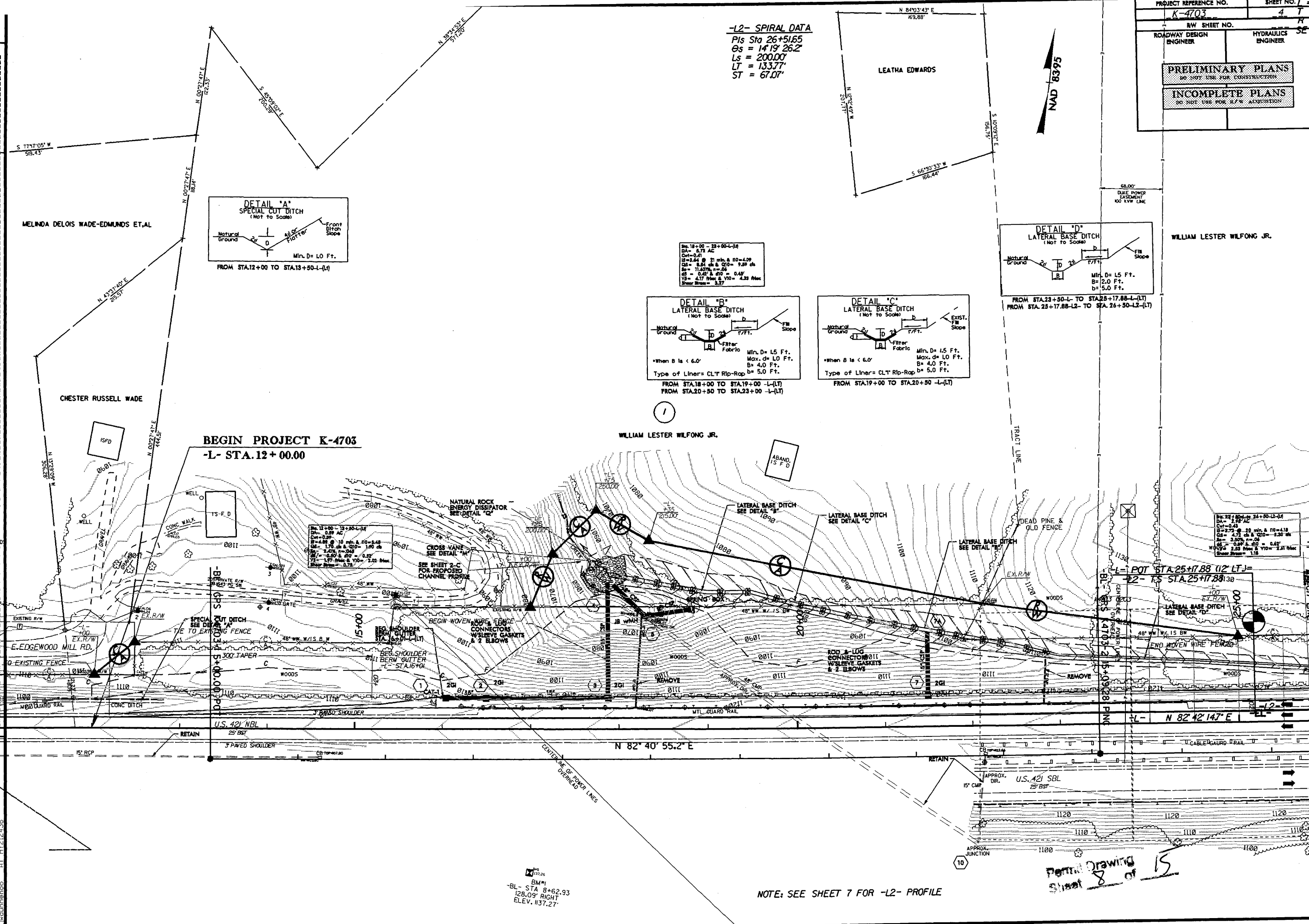
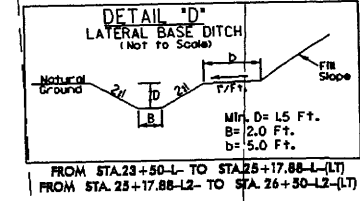
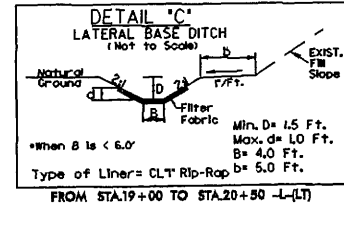
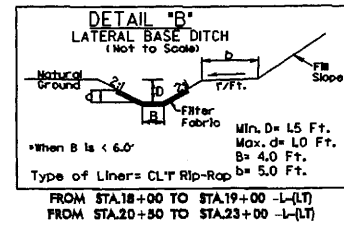

MELINDA DELOIS WADE-EDMUNDS ET.AL

CHESTER RUSSELL WADE

BEGIN PROJECT K-4703
 -L- STA.12+00.00

WILLIAM LESTER WILFONG JR.

WILLIAM LESTER WILFONG JR.

Sta. 24+00 - 26+50-L-04
 DA = 0.73 AC
 Cs = 0.41
 Ls = 27.00' 20 min. & 10" = 4.18'
 Os = 4.73' @ 30' & 300' = 5.30' @ 30'
 Ls = 3.2079' = 0.41'
 Os = 0.21' @ 30' = 0.41'
 Ls = 4.17' Max. & 170' = 4.23' Max.
 Slope = 3.37'

BM+
 STA 8+62.93
 128.09' RIGHT
 ELEV. 1137.27'

NOTE: SEE SHEET 7 FOR -L2- PROFILE

Partial Drawing
 Sheet 8 of 15

STA.10+00.00

21-MAY-2007 10:38
 R:\Hydraulics\K-4703_hyd.dwg
 Jeddunshoo AT HY212136

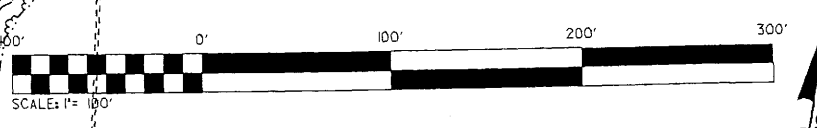

NAD 83 8395

-L2- CURVE DATA

Pls Sta 51+77.4 Os = 4 46' 28.7" Ls = 200.00' LT = 133.38' ST = 66.71'	PI Sta 53+08.73 Δ = 11 50' 06.5" (LT) D = 4 46' 28.7" L = 247.87' T = 124.38' SE = 1,200.00'	Pls Sta 55+04.80 Os = 0 27' 30.0" Ls = 200.00' LT = 127.55' ST = 72.57'	PI Sta 58+14.24 Δ = 1 40' 12.3" (LT) D = 0 27' 31.7" L = 364.0' T = 182.02' R = 12,488.00'
--	---	---	---

SE = SEE PLANS

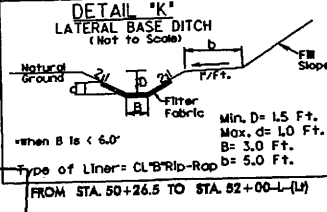
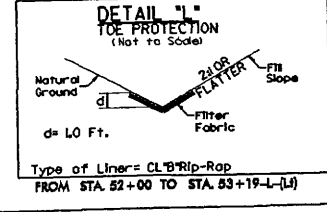
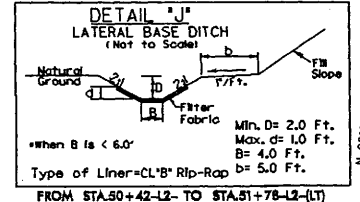
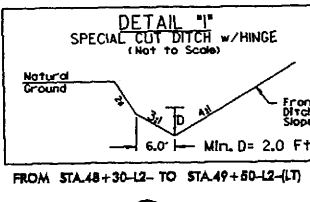

BESSIE B. HARRIS ET AL
DB 544 PG 504

BOBBY MARSHALL PARKS
DB 584 PG 184

JAMES WILSON HARRIS & FRANK HARRIS
DB 697 PG 504

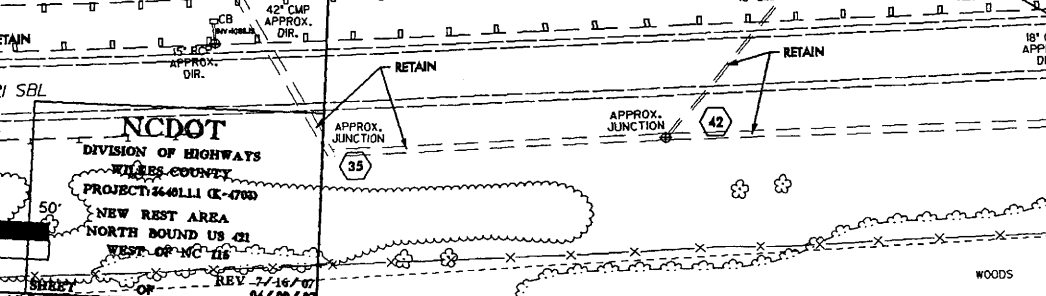
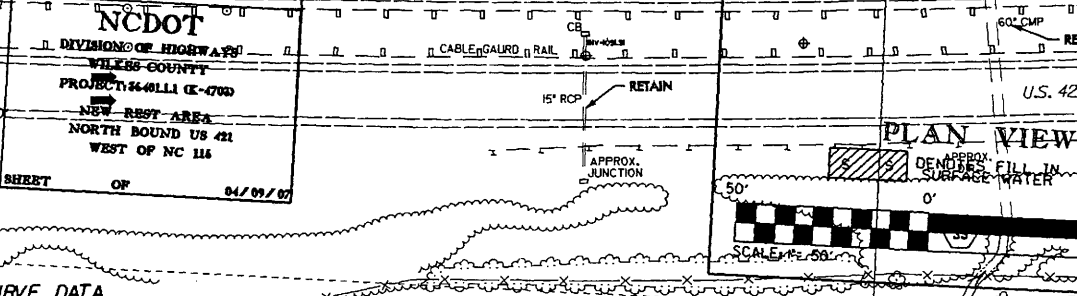
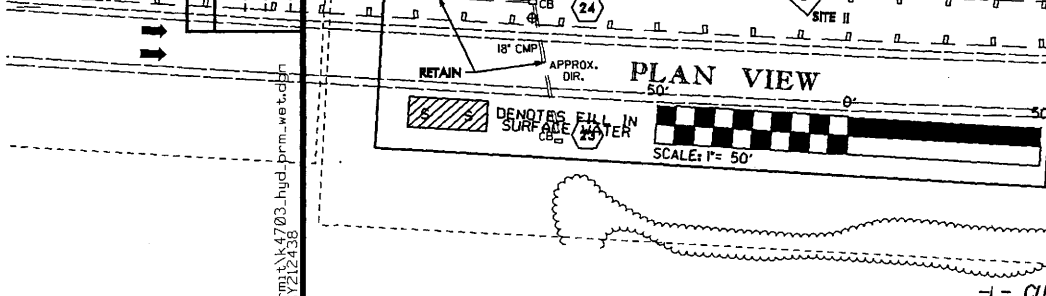
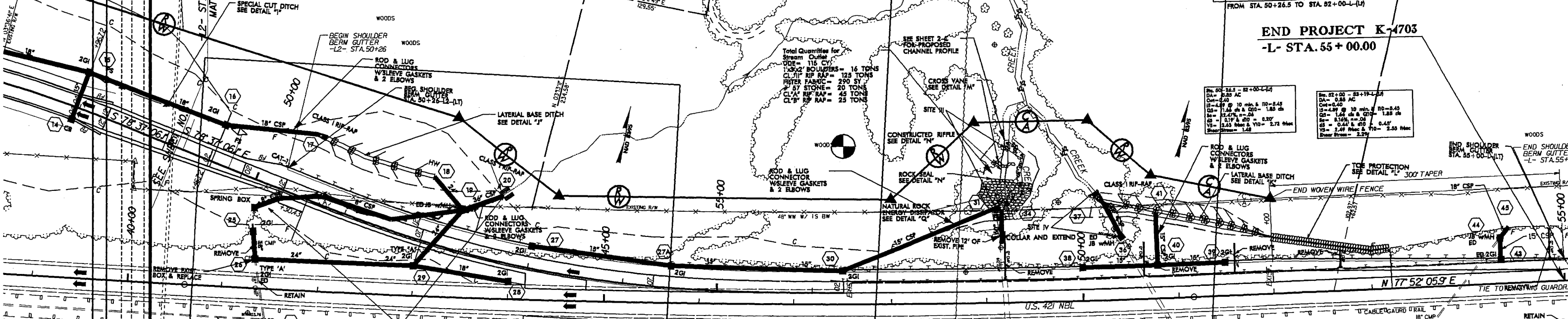

-L- CURVE DATA

PI Sta 45+88.19 Δ = 4 50' 08.8" (LT) D = 0 27' 30.0" L = 1,055.00' T = 527.82' R = 12,500.00'
--

SE = SEE PLANS

NOTES: SEE SHEET 9 & 10 FOR -L2- PROFILE

90F15

16-JUL-2007 14:36
c:\hydraulics\perry\k-4703\hgd\perry\we.t.dgn
pasepard A1 HY212438

PROJECT REFERENCE NO. K-4703	SHEET NO. 6
RAW SHEET NO.	
ROADWAY DESIGN ENGINEER	HYDRAULICS ENGINEER

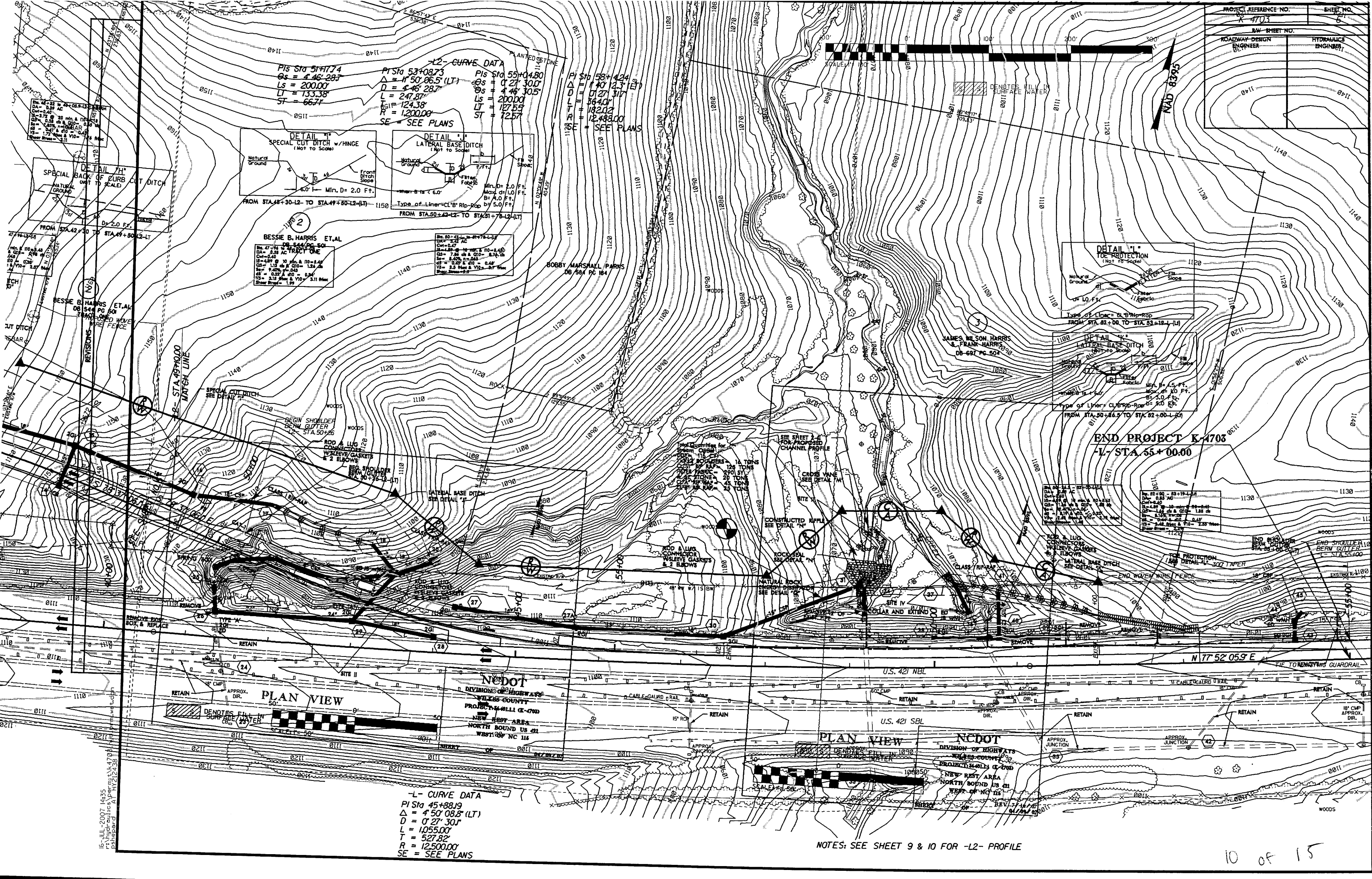

-L2- CURVE DATA
 PIS Sta 51+17.4
 $\Delta = 4' 46' 28.7''$
 $L = 200.00'$
 $T = 133.38'$
 $ST = 66.71'$

PIS Sta 53+08.73
 $\Delta = 11' 50' 06.5''$ (LT)
 $D = 4' 46' 28.7''$
 $L = 247.87'$
 $R = 1200.00'$
 $SE = \text{SEE PLANS}$

PIS Sta 55+04.80
 $\Delta = 0' 27' 30.0''$
 $D = 4' 46' 30.5''$
 $L = 200.00'$
 $LT = 127.63'$
 $ST = 72.57'$

PIS Sta 58+4.24
 $\Delta = 11' 40' 23.7''$ (LT)
 $D = 4' 46' 30.5''$
 $L = 192.02'$
 $ST = 12.488.00'$
 $SE = \text{SEE PLANS}$

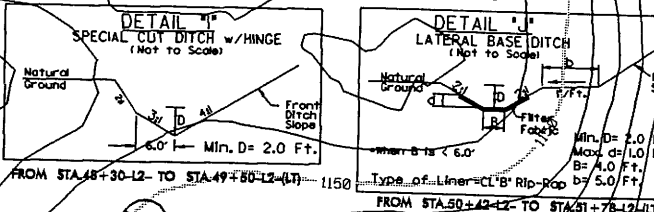

BESSIE B. HARRIS ET AL.
 DB 544 PG 504
 2.38 AC TRACT ONE
 C=0.40
 $D = 4.89' @ 10' MIN. \& NO. 8.40'$
 $CS = 1.10' @ 8' @ 1.24' @$
 $SE = 3.10' @ 10' @ 0.41'$
 $VS = 2.15' @ 10' @ 3.11' @$
 (Other values omitted for brevity)

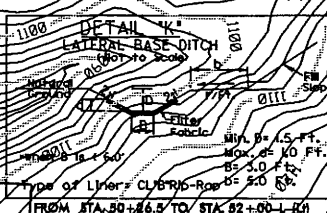
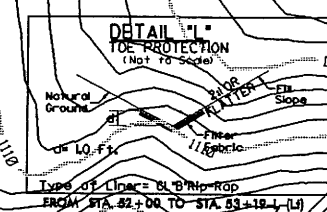

END PROJECT K-4703
 -L- STA 55+00.00

BESSIE B. HARRIS ET AL.
 DB 544 PG 504
 2.38 AC TRACT ONE
 C=0.40
 $D = 4.89' @ 10' MIN. \& NO. 8.40'$
 $CS = 1.10' @ 8' @ 1.24' @$
 $SE = 3.10' @ 10' @ 0.41'$
 $VS = 2.15' @ 10' @ 3.11' @$
 (Other values omitted for brevity)

PLAN VIEW

PLAN VIEW

-L- CURVE DATA
 PIS Sta 45+88.19
 $\Delta = 4' 50' 08.8''$ (LT)
 $D = 0' 27' 30.0''$
 $L = 1055.00'$
 $T = 527.82'$
 $R = 12500.00'$
 $SE = \text{SEE PLANS}$

NOTES: SEE SHEET 9 & 10 FOR -L2- PROFILE

8/23/06

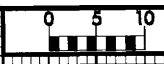

PROJ. REFERENCE NO. K-4703	SHEET NO. X-21
-------------------------------	-------------------

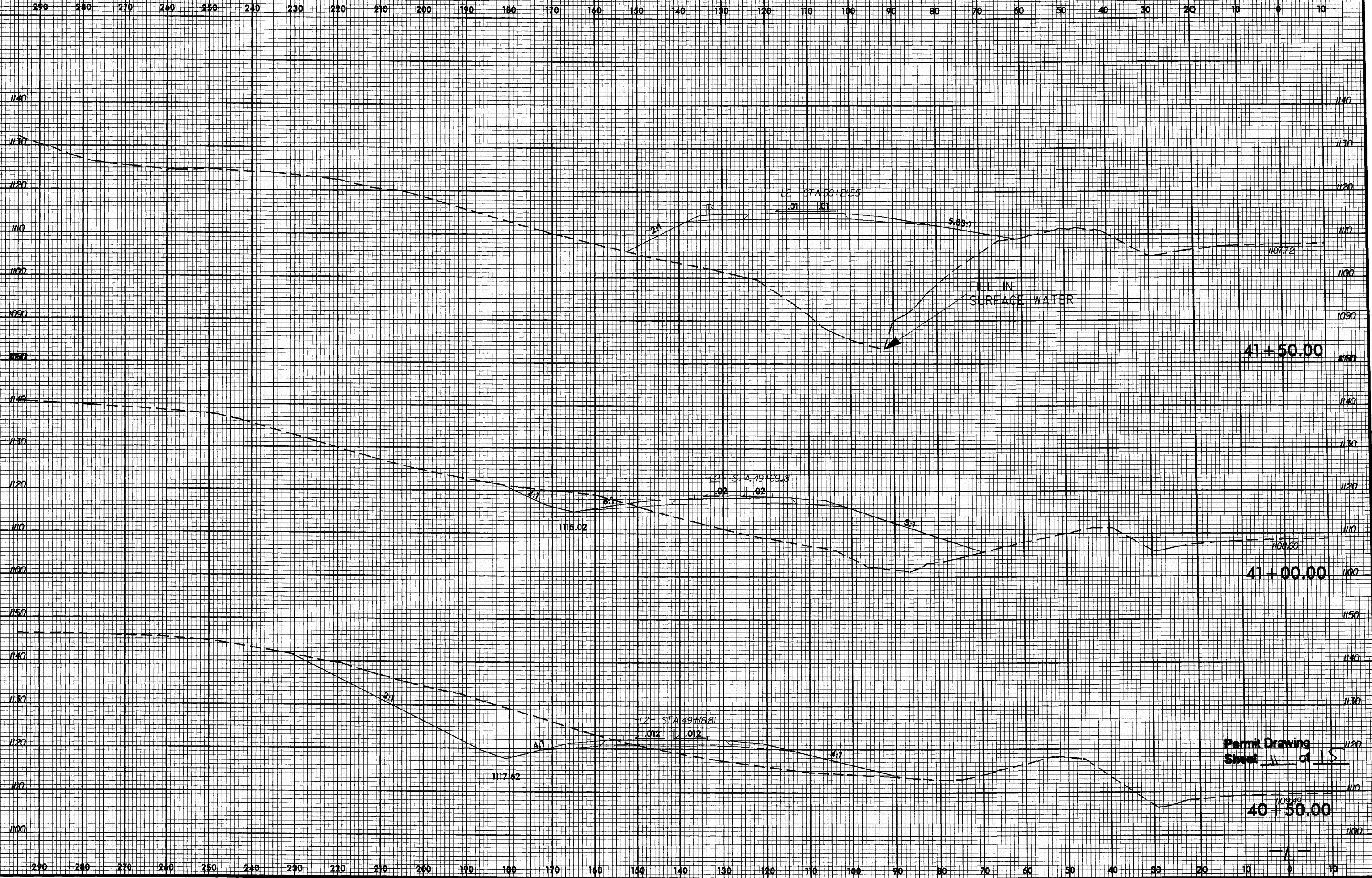

Permit Drawing
Sheet 11 of 15

04-APR-2007 12:45
c:\hired\cs\perm\k4703_rdy_1_xpl.dgn
pasterboard A

8/23/99



PROJ. REFERENCE NO. K-4703	SHEET NO. X-22
-------------------------------	-------------------

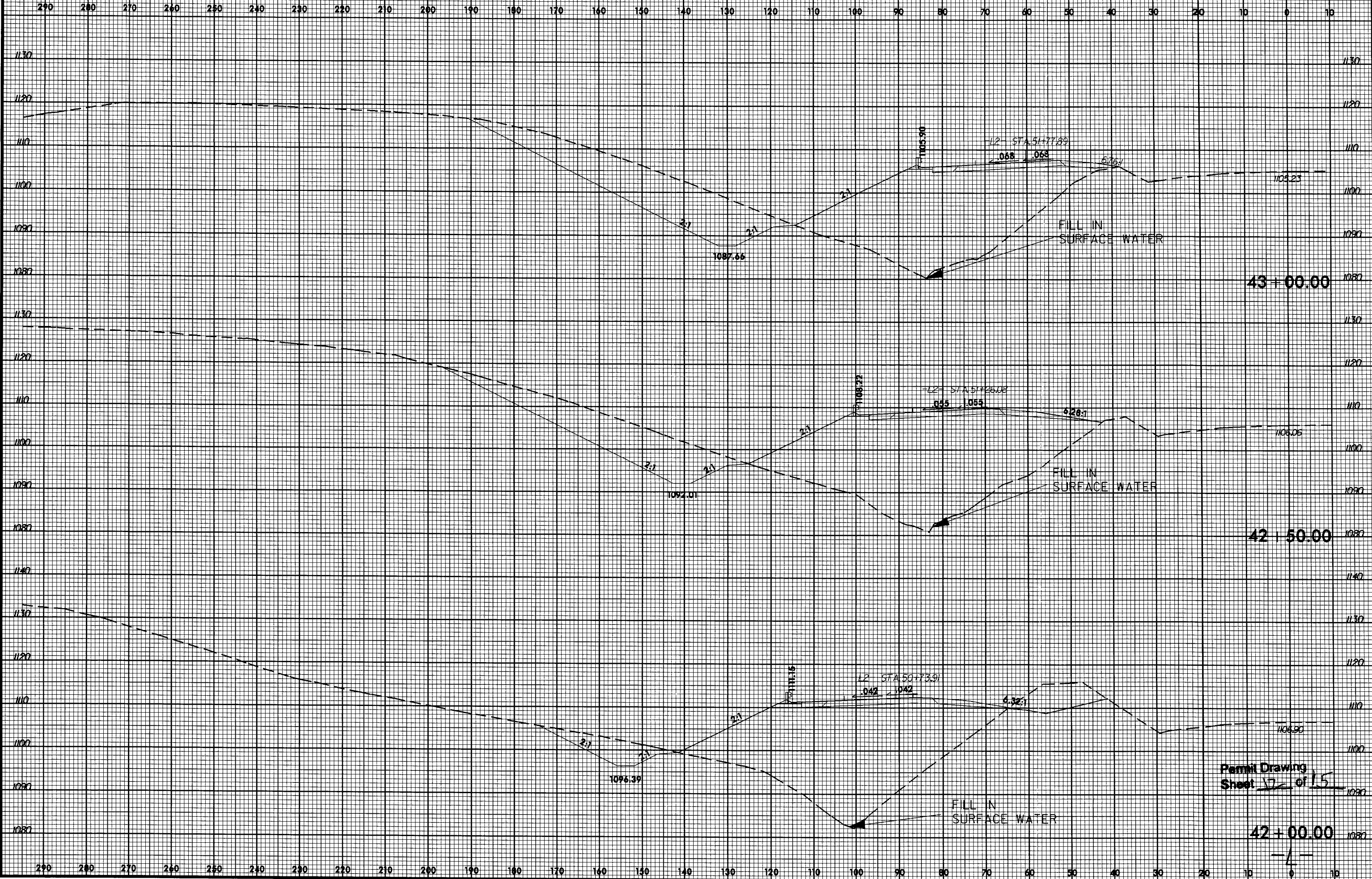

43 + 00.00

42 + 50.00

42 + 00.00

Permit Drawing Sheet 12 of 15

- 1 -

04-APR-2007 12:47
rt:\hydro\lites\perm\k4703_r.dwg I.xpl.dgn
shp

8/23/99



PROJ. REFERENCE NO. K-4703	SHEET NO. X-23
-------------------------------	-------------------

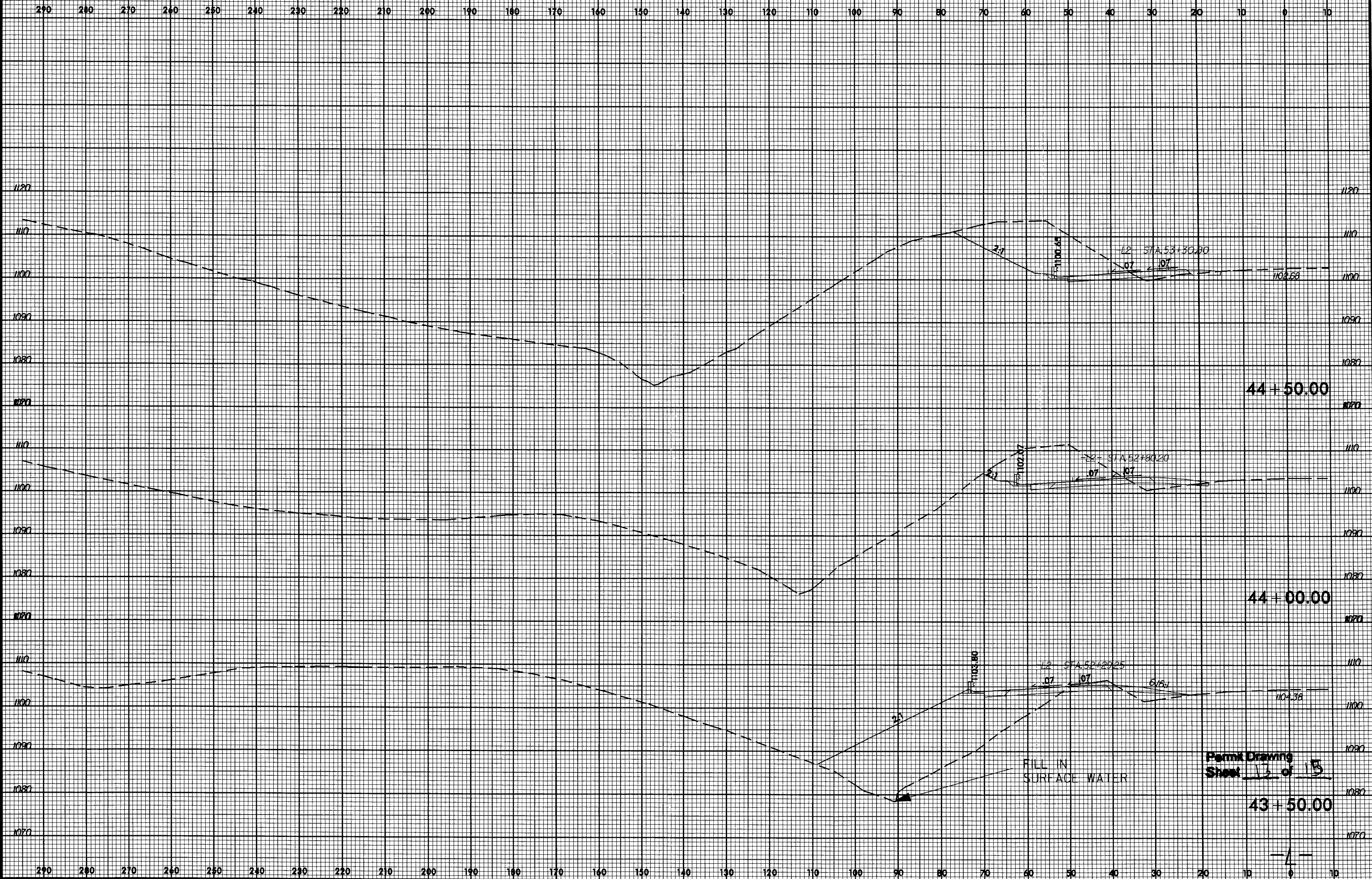

Permit Drawing
Sheet 12 of 15

43 + 50.00

- 1 -

04-APP-2007 1247
r:\hyd\ulica\perm\k4703.rdy_1_xpl.dgn
ashpard HY212438

PROPERTY OWNERS
NAMES AND ADDRESSES

PARCEL NO.	NAMES	ADDRESSES
①	Lester Wilfong, Jr.	252 E. Edgewood Mill Rd. Wilkesboro, N.C. 228697
②	Bessie Harris, et al C/O Mary Smith	675 Camp Joe Harris Rd. N. Wilkesboro, N.C. 28659
③	James Wilson Harris	1195 Camp Joe Harris Rd. N. Wilkesboro, N.C. 28659

NCDOT
DIVISION OF HIGHWAYS
WILKES COUNTY
PROJECT: 36401.1.1 (K-4703)

NEW REST AREA
NORTH BOUND US 421
WEST OF NC 115

SHEET 14 OF 15 04/09/07

WETLAND PERMIT IMPACT SUMMARY

Site No.	Station (From/To)	Structure Size / Type	WETLAND IMPACTS						SURFACE WATER IMPACTS					
			Permanent Fill In Wetlands (ac)	Temp. Fill In Wetlands (ac)	Excavation in Wetlands (ac)	Mechanized Clearing in Wetlands (ac)	Hand Clearing in Wetlands (ac)	Permanent SW impacts (ac)	Temp. SW impacts (ac)	Existing Channel Impacts Permanent (ft)	Existing Channel Impacts Temp. (ft)	Natural Stream Design (ft)		
I	17+60 to	48" CSP										115		
	18+82 -L- LT	8" CSP TO JB										81		
II	41+30 TO	8" CSP TO										278		
	43+93 -L- LT	36" CSP												
III	49+14 TO	60" CSP										124		
	49+43 -L- LT													
IV	49+77 TO	42" CSP										59		
	50+43 -L- LT													
TOTALS:												657		

NC DEPARTMENT OF TRANSPORTATION
 DIVISION OF HIGHWAYS
 WILKES COUNTY
 WBS - 36401.1.1 (K-4703)
 SHEET **15 of 15** REV. 07/19/07

See Sheet 1-A For Index of Sheets
See Sheet 1-B For Conventional Symbols

STATE OF NORTH CAROLINA
DIVISION OF HIGHWAYS

WILKES COUNTY

LOCATION: NEW REST AREA - NORTHBOUND US 421
WEST OF NC 115

TYPE OF WORK: GRADING, PAVING, AND DRAINAGE

STATE	STATE PROJECT REFERENCE NO.	SHEET NO.	TOTAL SHEETS
N.C.	K-4703	1	
STATE PROJ. NO.	P.A. PROJ. NO.	DESCRIPTION	
36401.1.1	NHS-421(32)	PE	

TIP PROJECT: K-4703

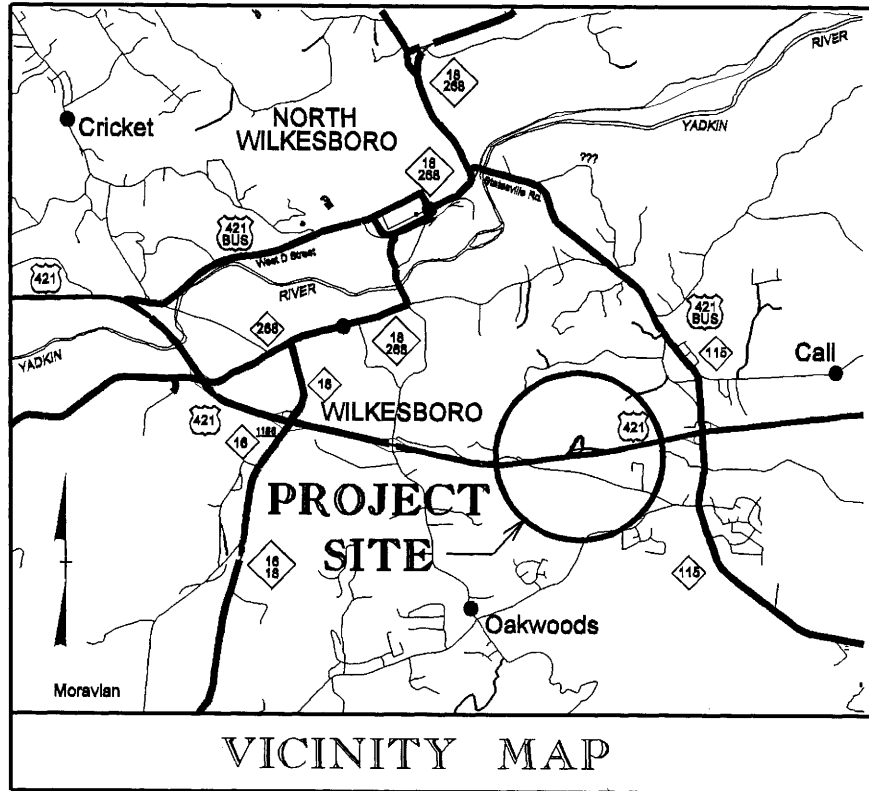

CONTRACT: C201679

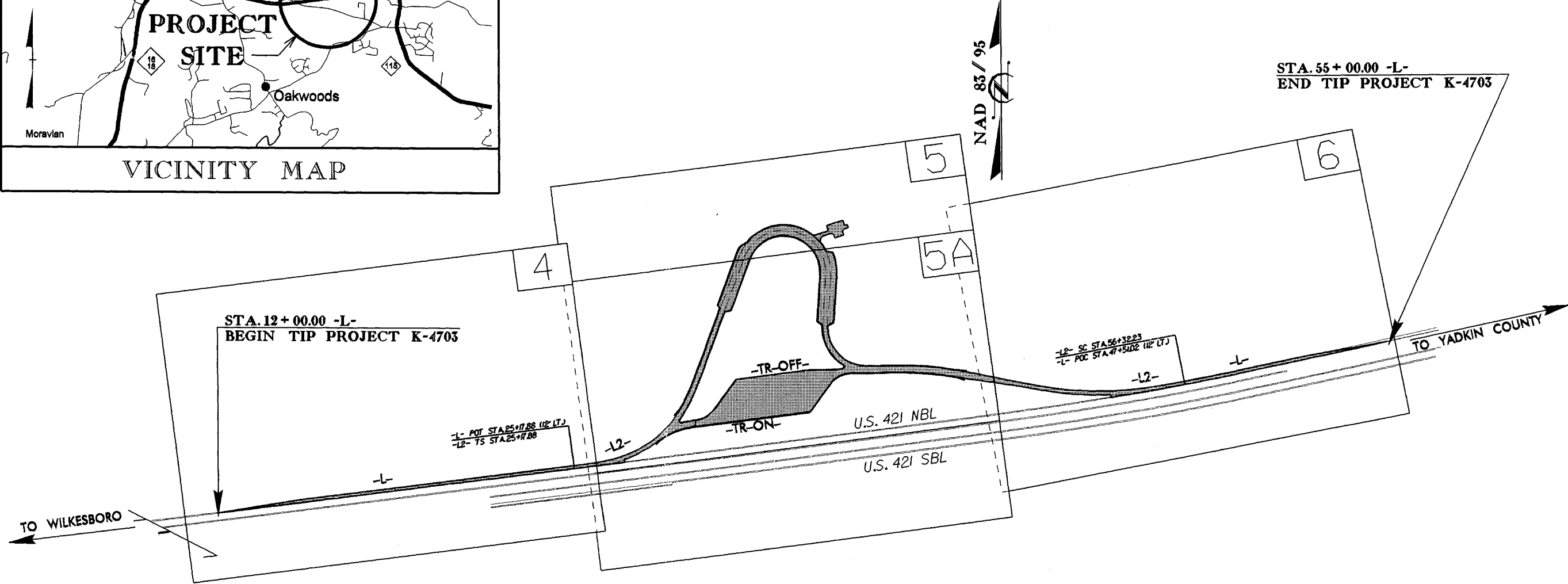

THIS PROJECT IS NOT WITHIN ANY MUNICIPAL BOUNDARIES
NOTE: CLEARING ON THIS PROJECT SHOULD BE PERFORMED TO THE LIMITS ESTABLISHED BY METHOD _____

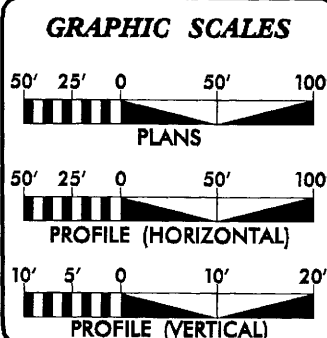

DESIGN DATA

ADT 2007 =	1000
ADT 2030 =	1500
DHV =	11 %
D =	100 %
T =	32% *
V =	20MPH
FUNC. CLASS. =	REST AREA
* TTST 28%	DUAL 4%

PROJECT LENGTH

LENGTH ROADWAY TIP PROJECT K-4703 =	0.981 MILES
TOTAL LENGTH OF TIP PROJECT K-4703 =	0.981 MILES

Prepared In the Office of:
DIVISION OF HIGHWAYS
1000 Birch Ridge Dr.
Raleigh, NC 27610

2006 STANDARD SPECIFICATIONS

RIGHT OF WAY DATE: N/A

LETTING DATE: SEPTEMBER 18, 2007

ROGER D. THOMAS, P.E.
PROJECT ENGINEER

MICHAEL W. LITTLE, P.E.
PROJECT DESIGN ENGINEER

HYDRAULICS ENGINEER _____ P.E.

ROADWAY DESIGN ENGINEER _____ P.E.

PRELIMINARY PLANS
DO NOT USE FOR CONSTRUCTION

INCOMPLETE PLANS
DO NOT USE FOR ACQUISITION

SIGNATURE: _____ P.E.

DIVISION OF HIGHWAYS
STATE OF NORTH CAROLINA

STATE HIGHWAY DESIGN ENGINEER _____ P.E.

10-APR-2007 11:11 AM A:\4703.rdy_tsh.dgn

6/2/99

PROJECT REFERENCE NO. K-4703	SHEET NO. 2
ROADWAY DESIGN ENGINEER	PAVEMENT DESIGN ENGINEER
INCOMPLETE PLANS <small>DO NOT USE FOR R/W ACQUISITION</small>	
PRELIMINARY PLANS <small>DO NOT USE FOR CONSTRUCTION</small>	

PAVEMENT SCHEDULE			
C1	PROP. APPROX. 3" ASPHALT CONCRETE SURFACE COURSE, TYPE S9.5B, AT AN AVERAGE RATE OF 168 LBS. PER SQ. YARD. IN EACH OF TWO LAYERS.	R1	2'-6" CONCRETE CURB & GUTTER
D1	PROP. APPROX. 4" ASPHALT CONCRETE INTERMEDIATE COURSE, TYPE I19.0B, AT AN AVERAGE RATE OF 456 LBS. PER SQ. YARD.	R2	CONCRETE SHOULDER BERM GUTTER
E1	PROP. APPROX. 3" ASPHALT CONCRETE BASE COURSE, TYPE B25.0B, AT AN AVERAGE RATE OF 342 LBS. PER SQ. YARD.	T	EARTH MATERIAL
J1	PROP. 8" AGGREGATE BASE COURSE	U	EXISTING PAVEMENT
J2	PROP. VAR. DEPTH AGGREGATE BASE COURSE		

NOTE: PAVEMENT EDGE SLOPES ARE 1:1 UNLESS SHOWN OTHERWISE

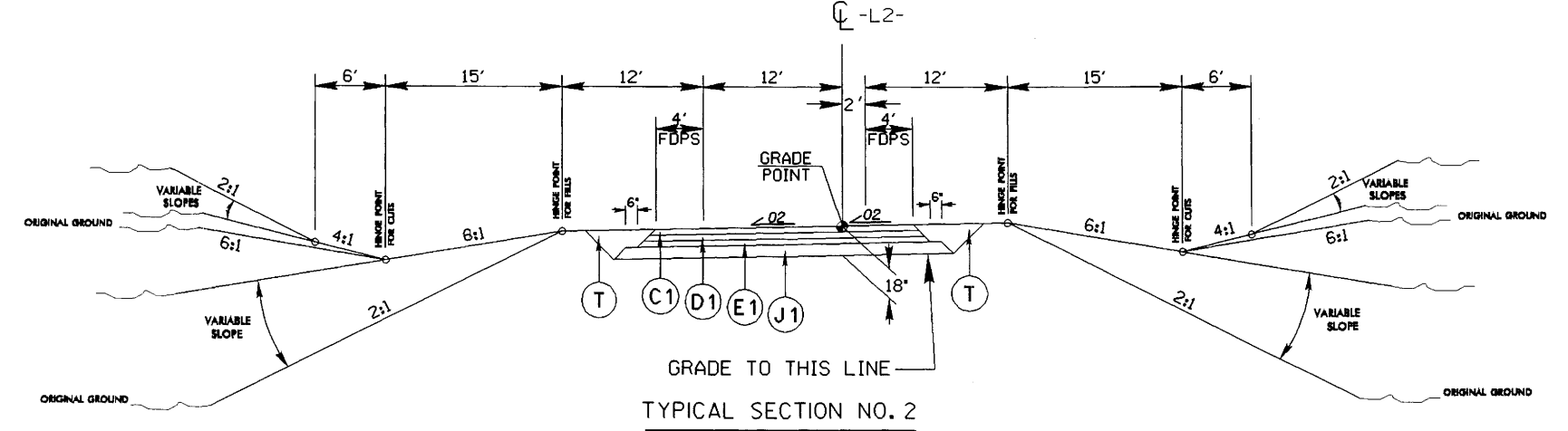
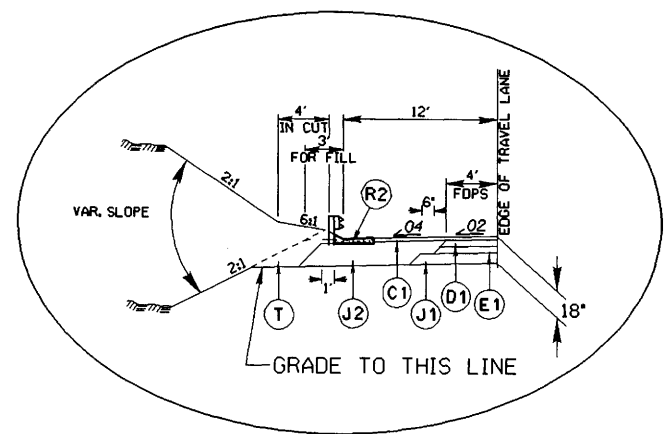
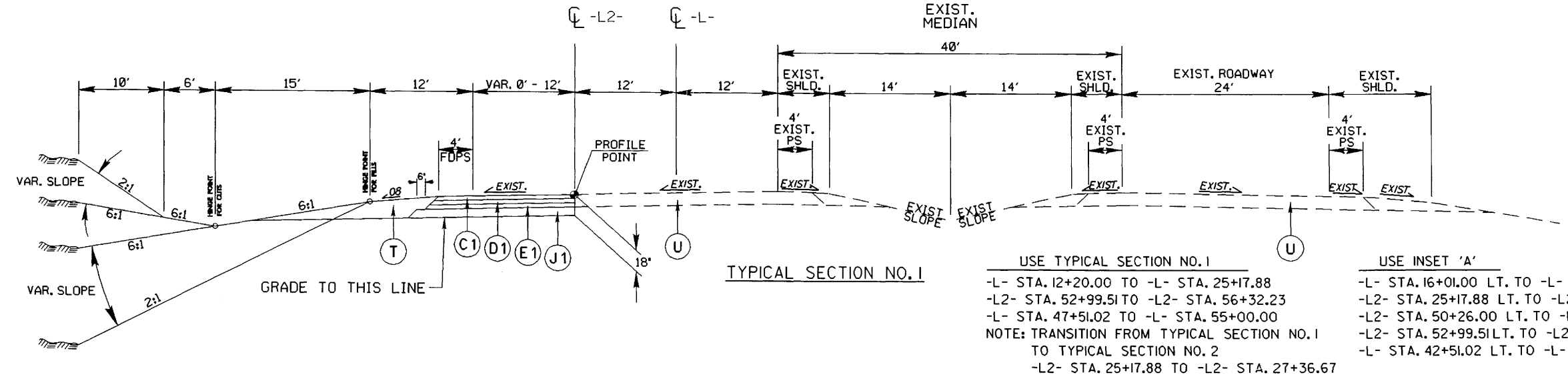

10-APR-2007 11:11
 4703.r.dwg_tup.dgn

6/2/99

PAVEMENT SCHEDULE	
C1	3" S9.5B
D1	4" I19.0B
E1	3" B25.0B
J1	8" ABC
J2	VAR. ABC
R1	2'-6" CONC. C&G
R2	CONC. SBG
T	EARTH MATERIAL

PROJECT REFERENCE NO. K-4703	SHEET NO. 2-A
ROADWAY DESIGN ENGINEER	PAVEMENT DESIGN ENGINEER
INCOMPLETE PLANS <small>DO NOT USE FOR R.F.W. ACQUISITION</small> PRELIMINARY PLANS <small>DO NOT USE FOR CONSTRUCTION</small>	

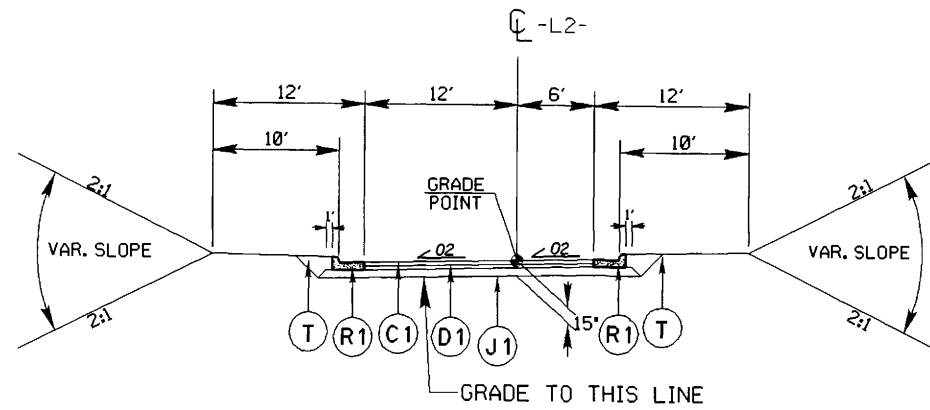

TYPICAL SECTION NO. 3

USE TYPICAL SECTION NO. 3
 -L2- STA. 29+50.00 TO -L2- STA. 33+88.32
 -L2- STA. 42+10.33 TO -L2- STA. 43+80.00

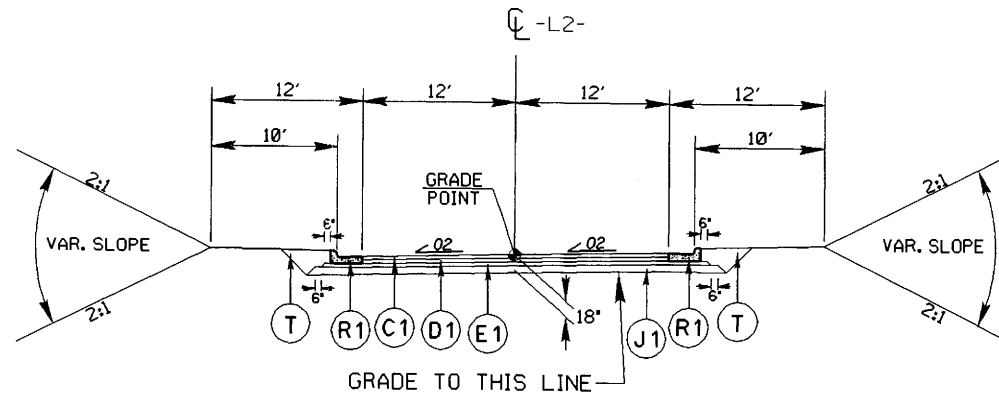

TYPICAL SECTION NO. 4

USE TYPICAL SECTION NO. 4
 -L2- STA. 43+80.00 TO -L2- STA. 48+30.37

NOTE: TRANSITION FROM TYPICAL SECTION NO. 4 TO TYPICAL SECTION NO. 2
 -L2- STA. 48+30.37 TO -L2- STA. 50+30.43

6/2/99

PAVEMENT SCHEDULE	
C1	3" S9.5B
D1	4" I19.0B
E1	3" B25.0B
J1	8" ABC
R1	2'-6" CONC. C&G
T	EARTH MATERIAL

PROJECT REFERENCE NO. K-4703	SHEET NO. 2-B
ROADWAY DESIGN ENGINEER	PAVEMENT DESIGN ENGINEER
INCOMPLETE PLANS <small>DO NOT USE FOR R/W ACQUISITION</small> PRELIMINARY PLANS <small>DO NOT USE FOR CONSTRUCTION</small>	

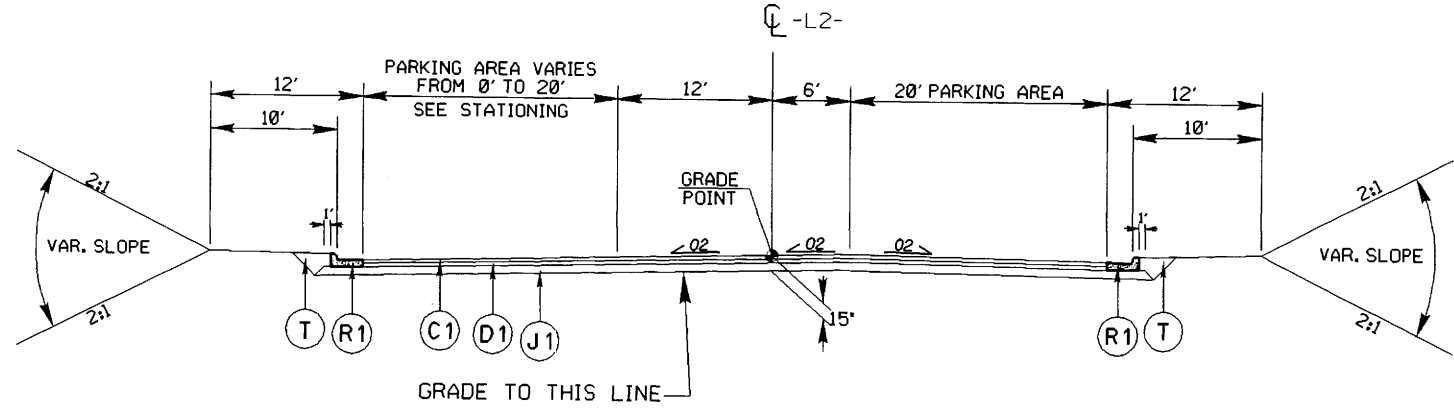

TYPICAL SECTION NO. 5

USE TYPICAL SECTION NO. 5
 -L2- STA. 33+88.32 TO -L2- STA. 36+13.87 (12' PARKING AREA ON LEFT)
 -L2- STA. 36+13.87 TO -L2- STA. 39+67.92 (0' PARKING AREA ON LEFT)
 -L2- STA. 39+67.92 TO -L2- STA. 42+10.33 (20' PARKING AREA ON LEFT)

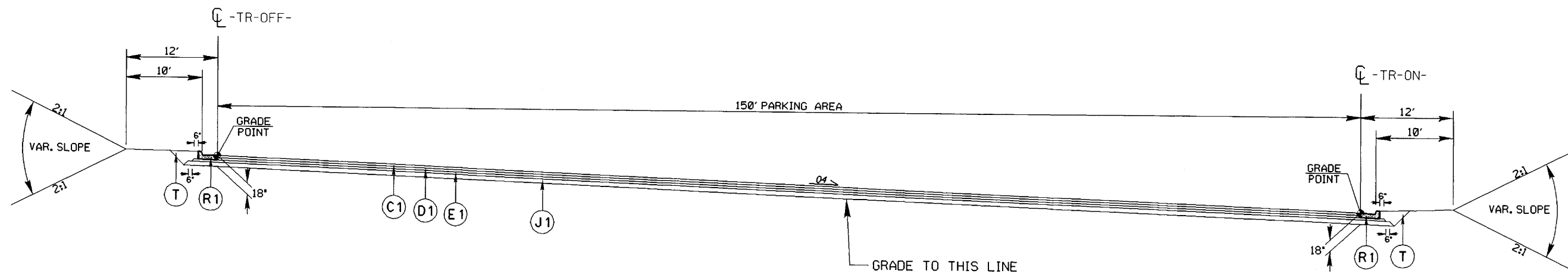

TYPICAL SECTION NO. 6

USE TYPICAL SECTION NO. 6
 -TR-ON- STA. 13+29.35 TO -TR-ON- STA. 15+79.35

10: APR-2007 11:12
 I:\PROJECTS\K-4703\rdy_tjg.dgn
 11:05:38 AM 2007

5/28/99

PROJECT REFERENCE NO. K-4703	SHEET NO. 2-C
ROADWAY DESIGN ENGINEER	HYDRAULICS ENGINEER
PRELIMINARY PLANS DO NOT USE FOR CONSTRUCTION	
INCOMPLETE PLANS DO NOT USE FOR R.F.W. ACQUISITION	

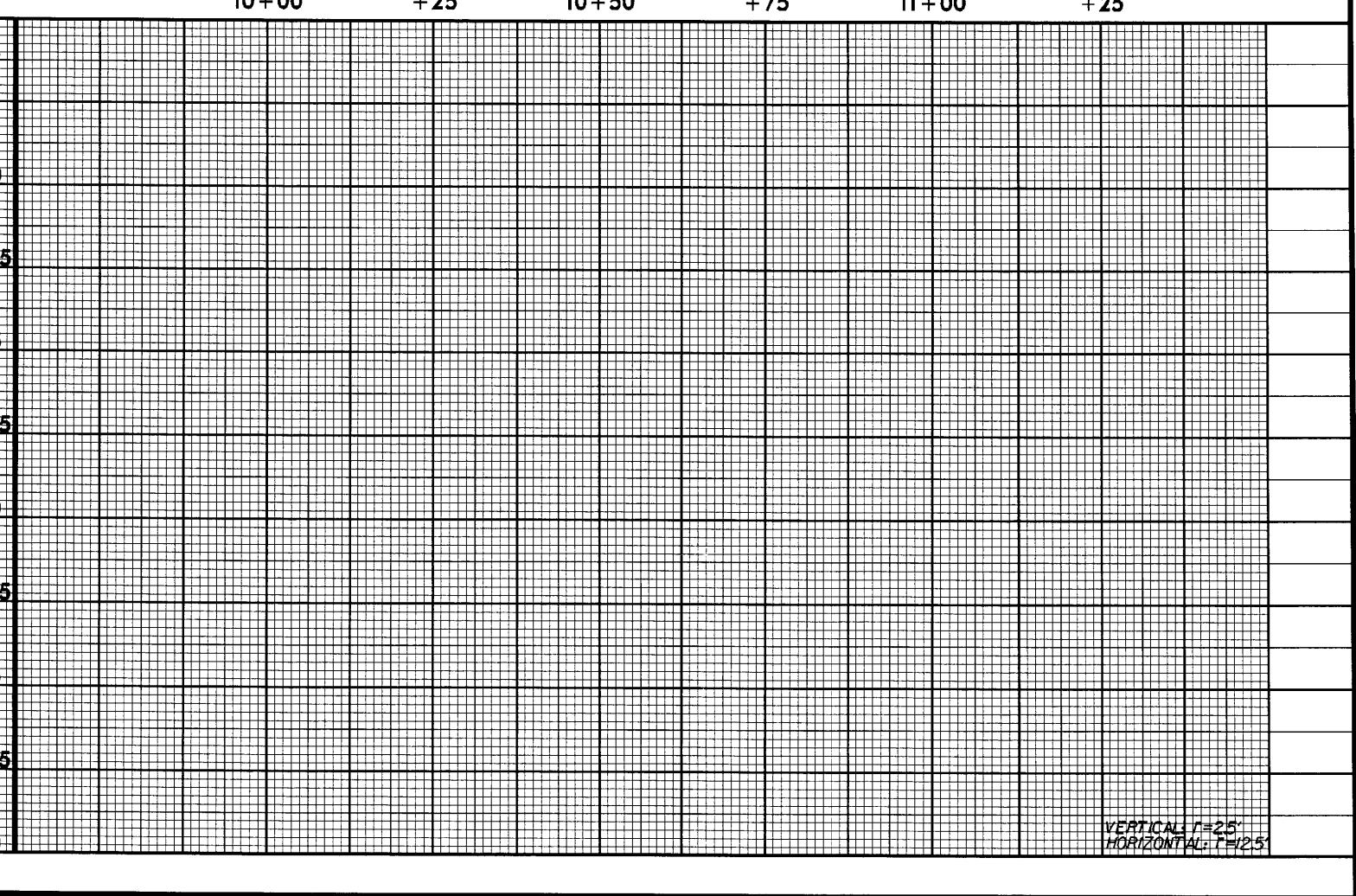
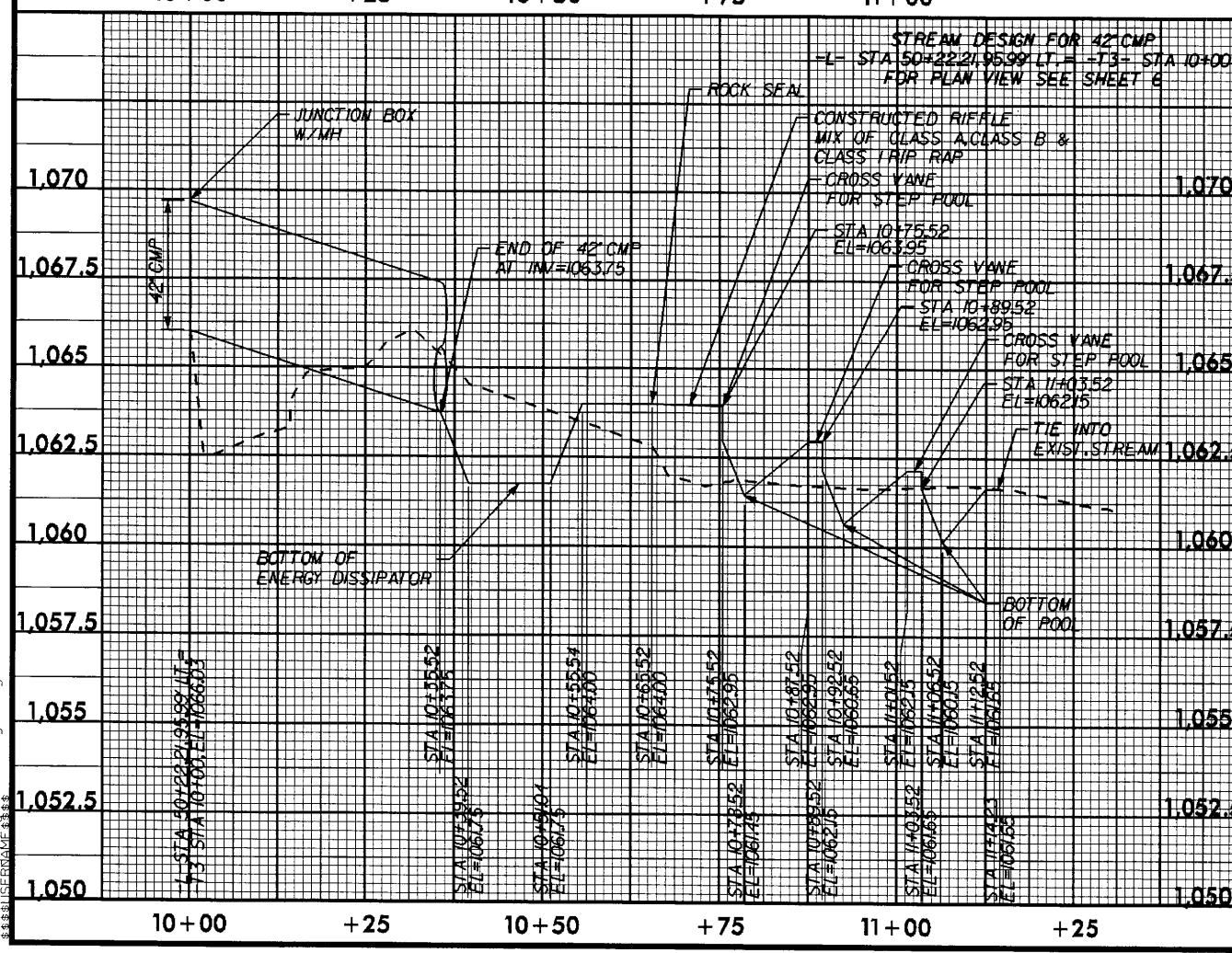
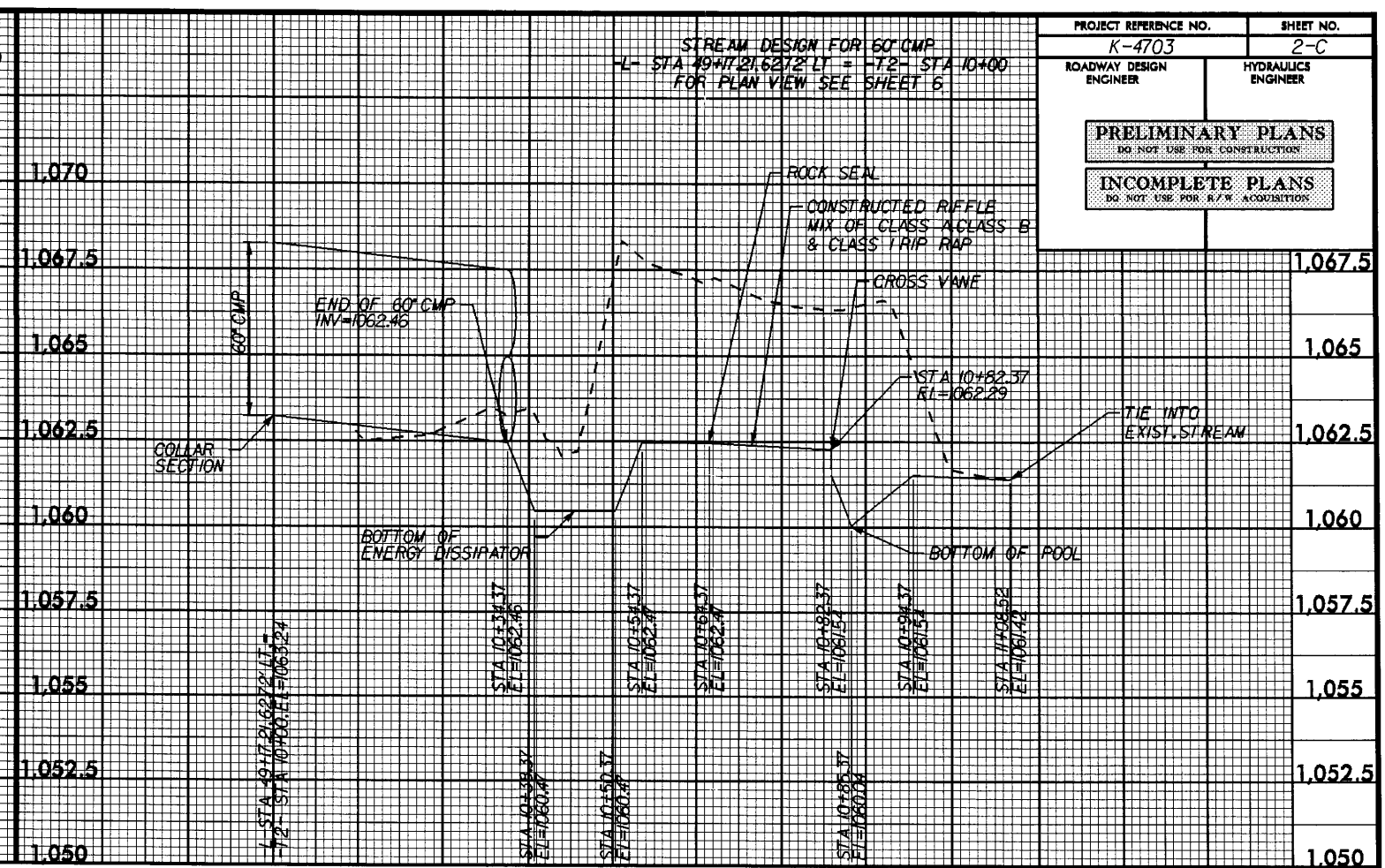
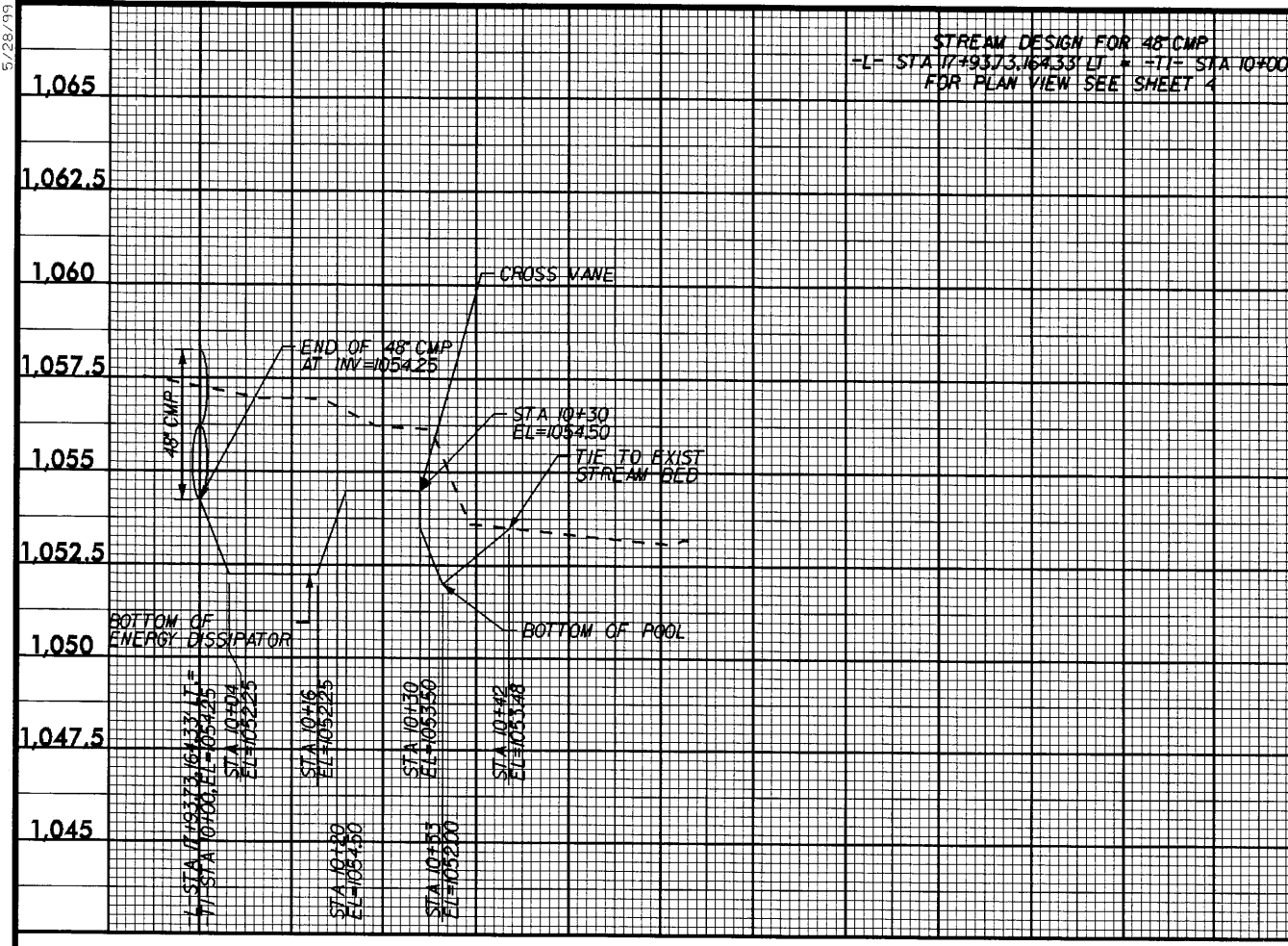

VERTICAL: 1"=25'
HORIZONTAL: 1"=25'

10-APR-2007 11:20
K:\AK4703.rdy_2c.dgn

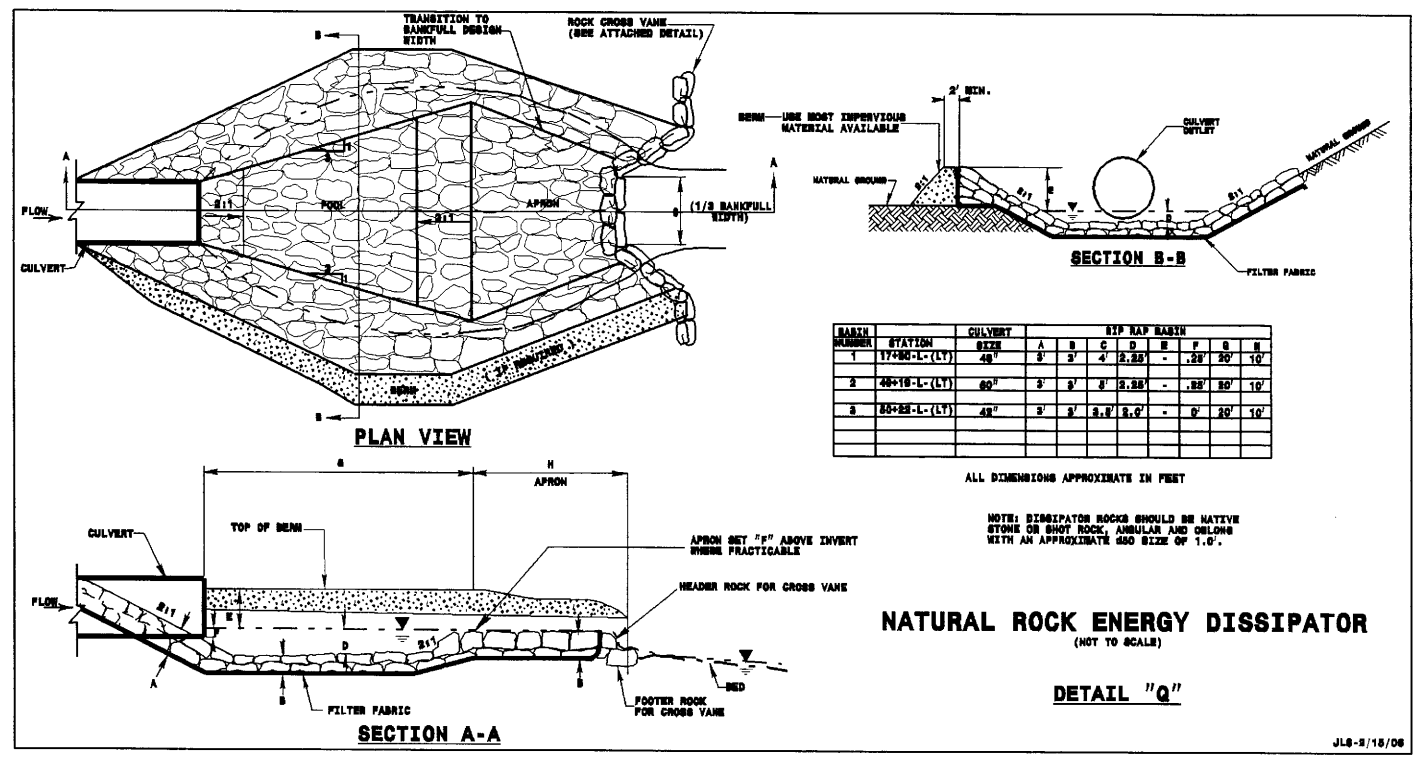
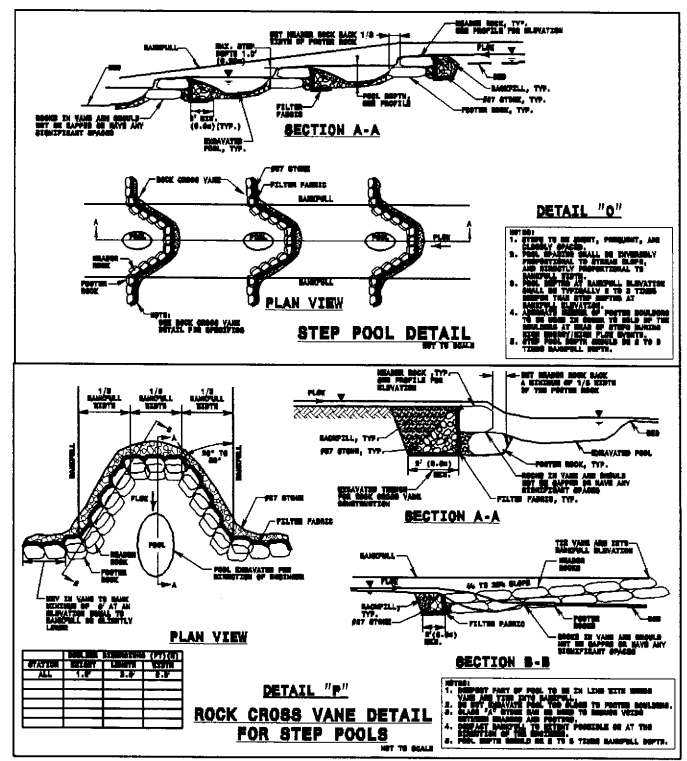

REVISIONS

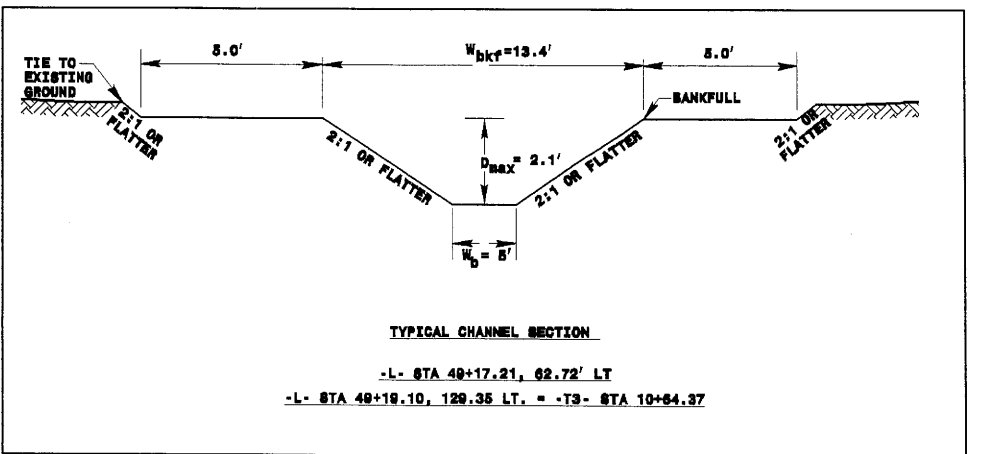
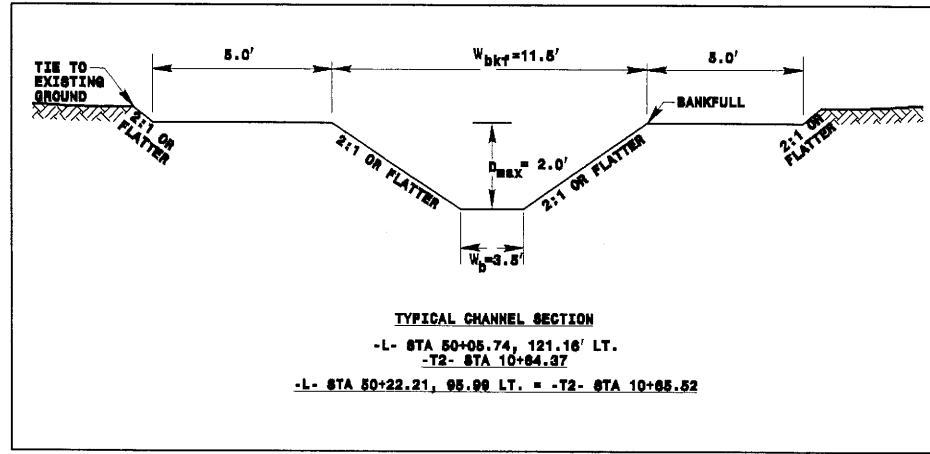
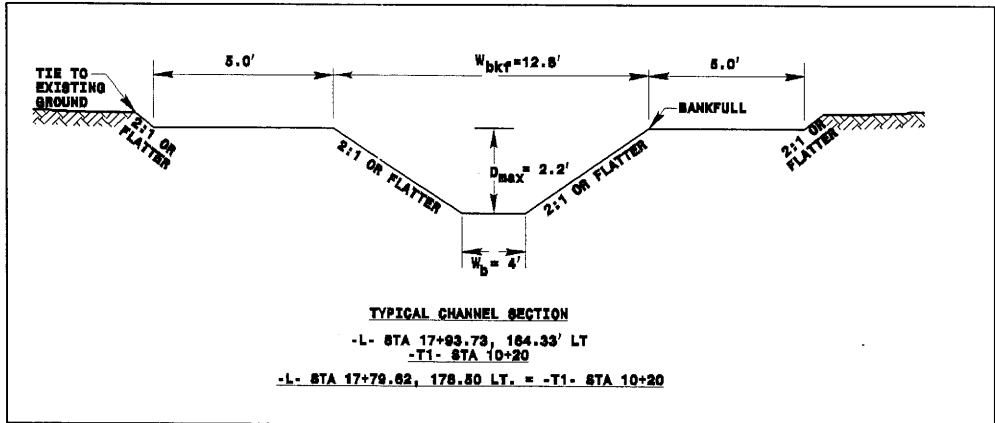
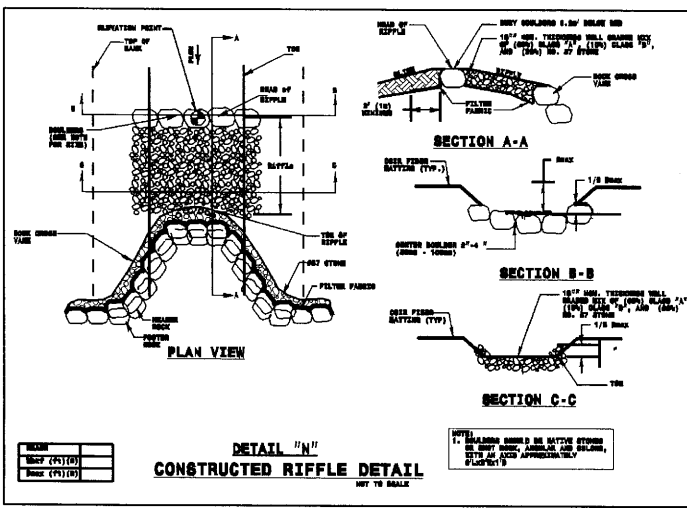

10-APR-2007 11:20
 P:\CADD\DWG\K4703.rdy-2d.dgn
 \$\$\$USERNAME\$\$\$

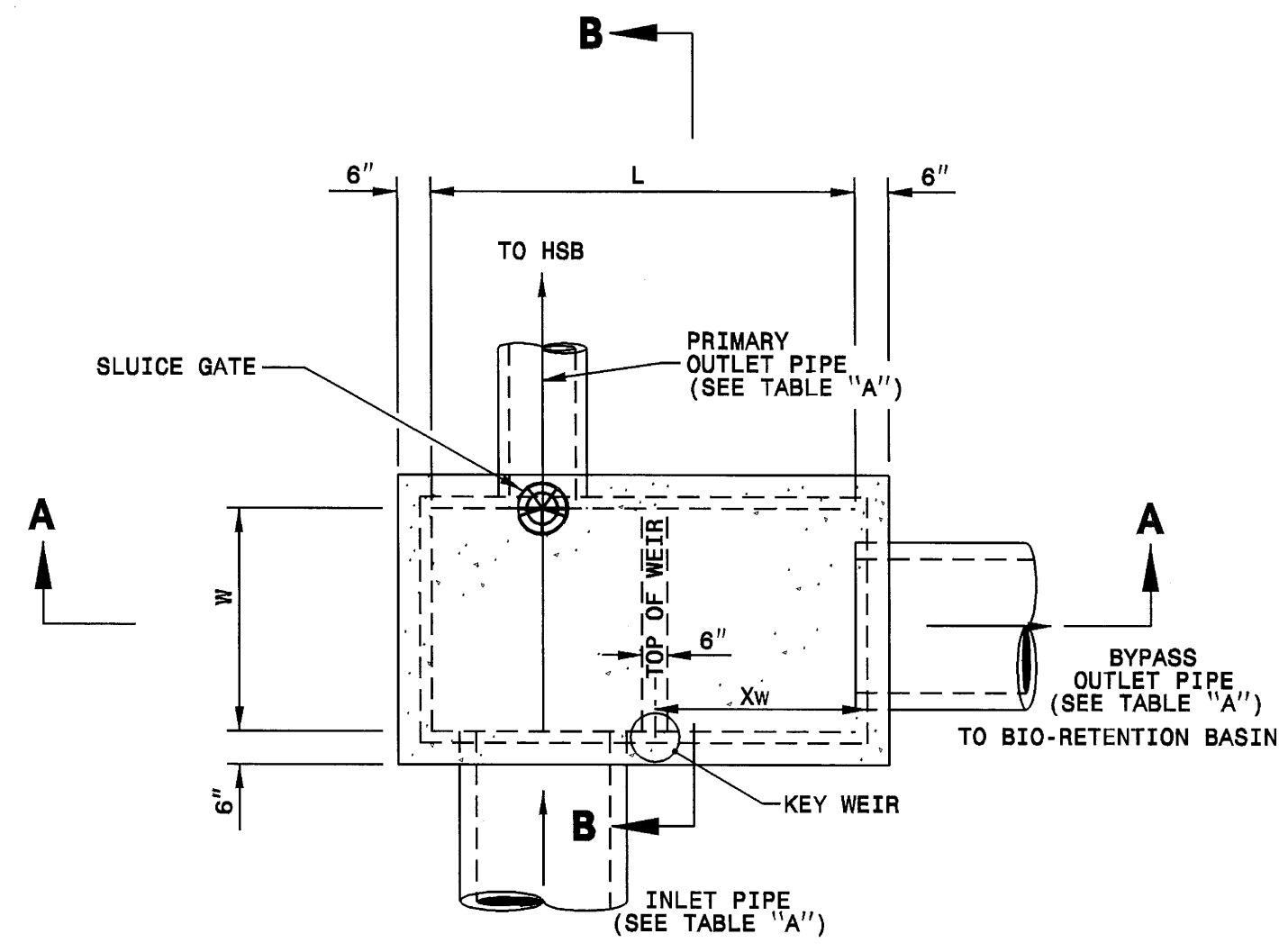

PLAN VIEW

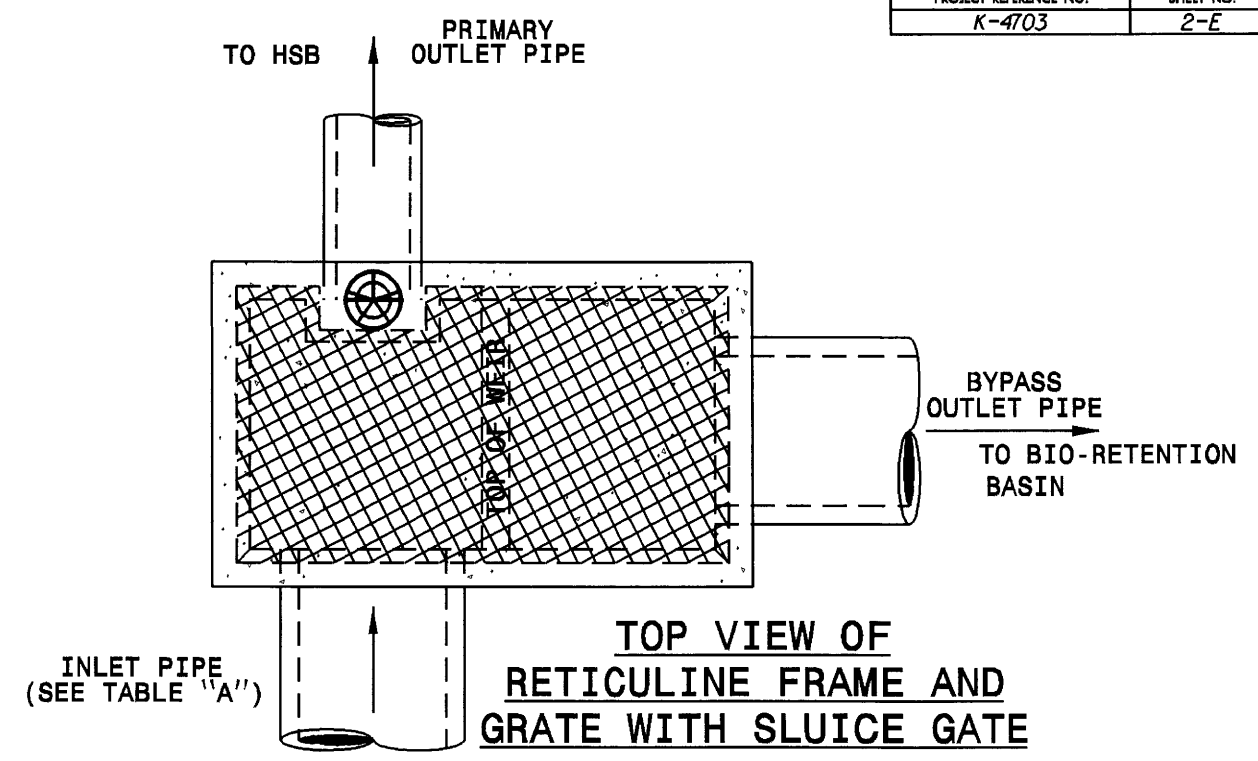

TOP VIEW OF RETICULINE FRAME AND GRATE WITH SLUICE GATE

TABLE "A"
PIPE SIZE AND INVERT ELEVATION

BASIN	INLET PIPE DIA.	PRIMARY OUTLET PIPE DIA.	SECONDARY OUTLET PIPE DIA.	INLET PIPE INV. ELEV.	PRIMARY OUTLET PIPE INV. ELEV.	SECONDARY OUTLET PIPE INV. ELEV.	CONCRETE QTY. (YD. ³)
Sta. 29+88-L2- (44.47 Lt)	24"	18"	24"	1126.59'	1126.59'	1126.59'	3.2

TABLE "B"
BOX AND WEIR SIZE & INVERT ELEVATION

BASIN	BOX DIMENSIONS			BOX INVERT ELEV.	TOP OF BOX INVERT ELEV.	WEIR HEIGHT (H _w)	WEIR LOCATION (X _w)
	L	W	H				
Sta. 29+88-L2- (44.47 Lt)	8'	4'	5.21'	1126.59'	1131.80'	18"	4'

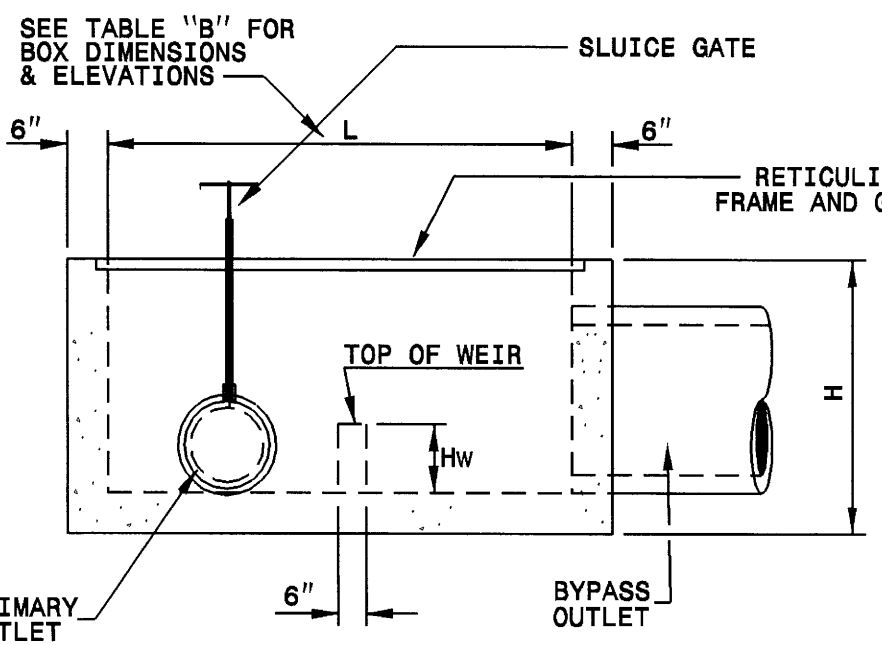

VIEW A-A

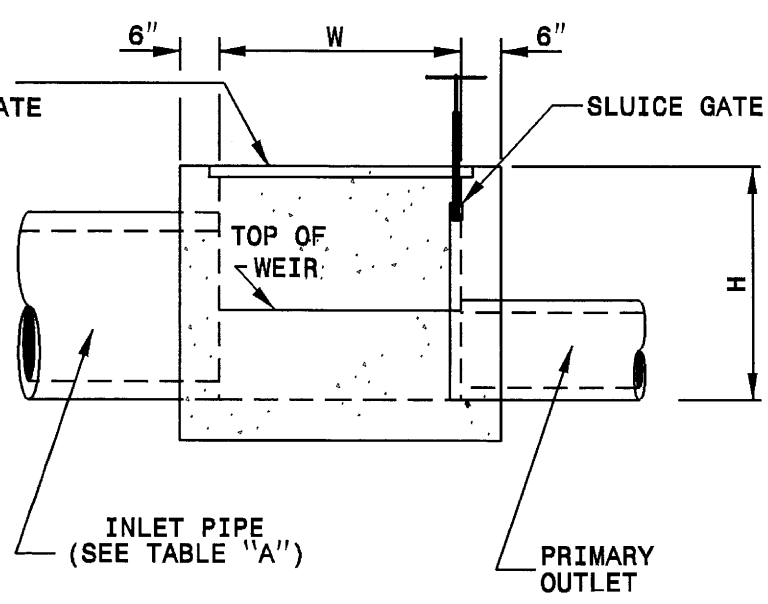

VIEW B-B

SEE TABLE "B" FOR BOX DIMENSIONS & ELEVATIONS

NOTE: (SEE TABLE "B" FOR WEIR HEIGHT & LOCATION)

- NOTES:**
- USE CLASS 'B' CONCRETE THROUGHOUT.
 - PLACE STEPS IN ALL STRUCTURES OVER 3' IN HEIGHT IN ACCORDANCE WITH STD.NO. 840.66. (12" ON CENTERS)
 - RETICULINE FRAMES AND GRATES TO BE APPROVED BY THE ENGINEER.
 - USE REBAR PLACEMENT AND QUANTITIES AS SHOWN BY THE ENGINEER.
 - USE REBAR PLACEMENT AS SHOWN IN STD.NO. 840.31.

**PROJECT SERVICES UNIT
STANDARDS AND SPECIAL DESIGN**
Office 919-250-4128 FAX 919-250-4119

**SPLITTER BOX
DETAILS**

ORIGINAL BY: TSpell DATE: Jan. 16, 2006
 MODIFIED BY: jwdunneha DATE: 2-19-07
 CHECKED BY: DATE:
 FILE SPEC.: r:\hydraulics\k4703_splitter_box.dgn

5/14/99
I:\APS-2007_1120...k4703_r.dwg...2.e.dgn
\$\$\$\$\$USERNAME\$\$\$\$\$

HAZARDOUS SPILL BASIN DETAIL

Sta. 30+30-L2-(93'Lt)

MATERIALS	
(A)	10MM IMPERVIOUS PLASTIC
(B)	18" RCP INLET PIPE
(C)	24" RCP OUTFALL PIPE
(D)	TOP SOIL AND BERMUDA SOD
(E)	OUTLET CONTROL STRUCTURE (SEE SPECIAL DETAIL)
(F)	CLASS B RIP RAP

NOTE:
 SEE PLAN SHEET #5 FOR SHAPE AND SIZE OF BASIN
 SURFACE AREA AT ELEV. 1126 = 1784 SF.
 SURFACE AREA AT ELEV. 1129 = 4115 SF.

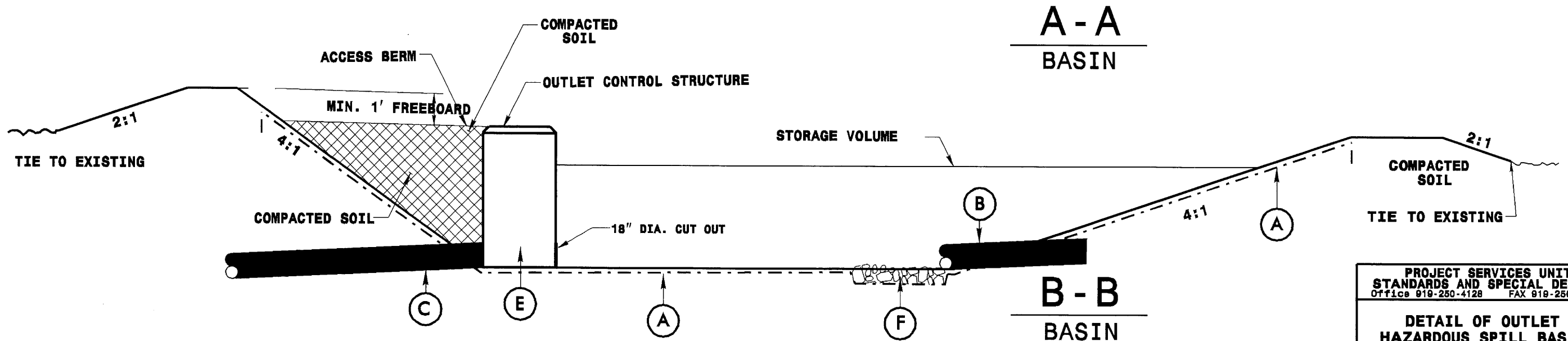
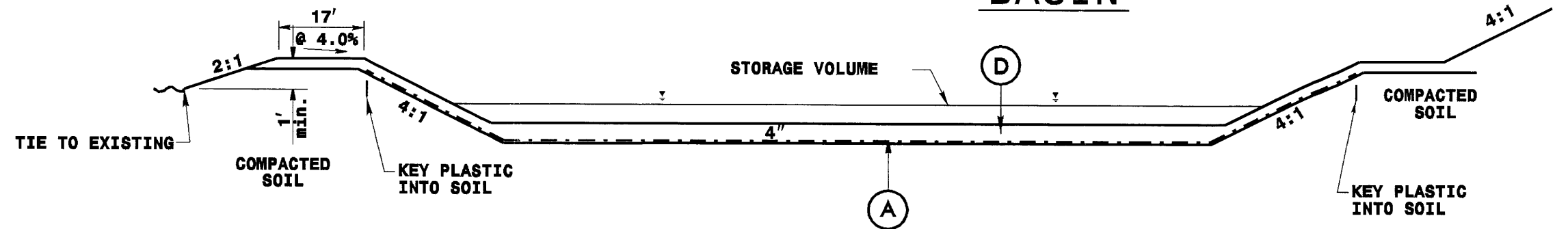
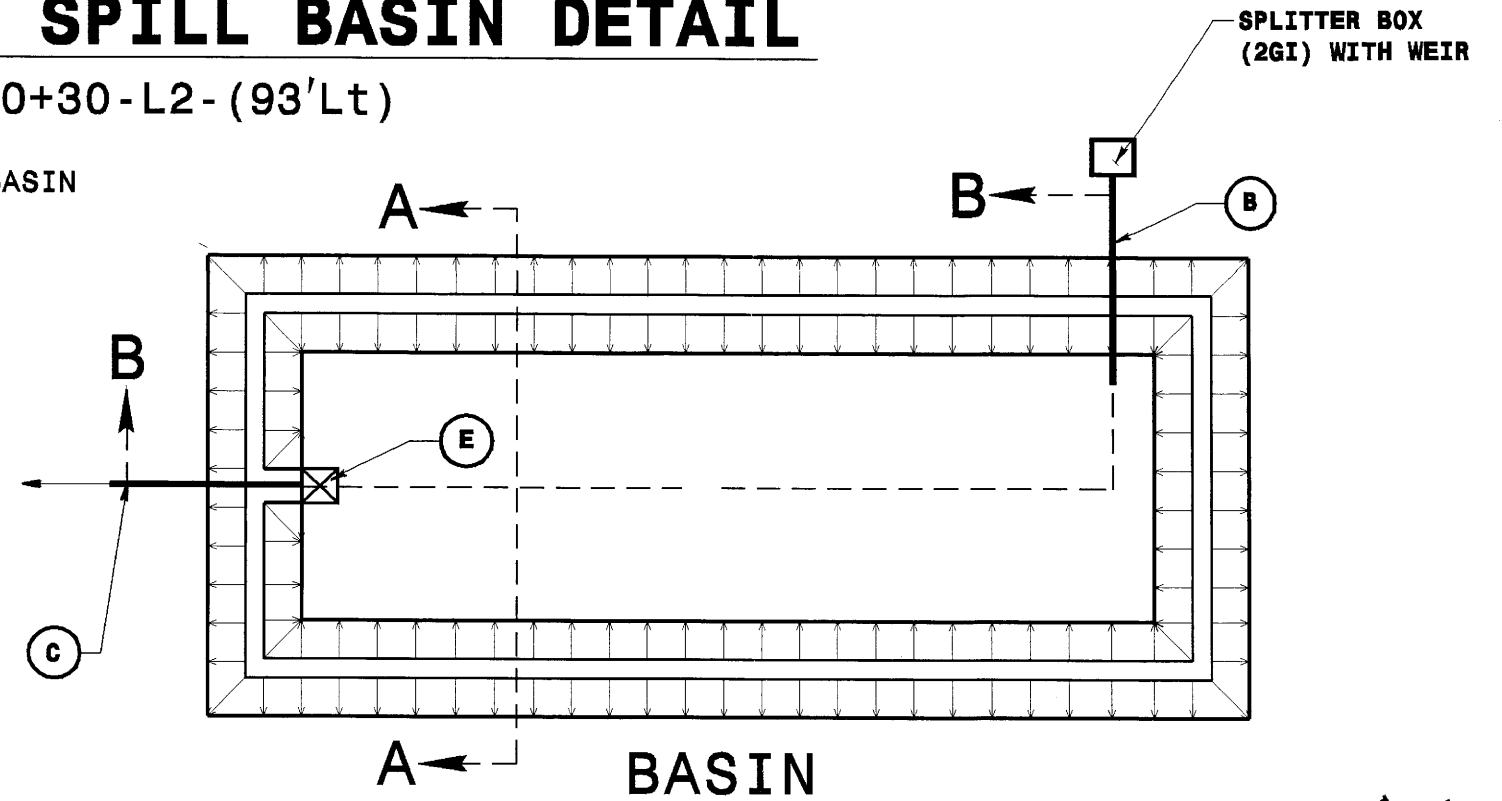

TYPICAL SECTIONS

*NOT TO SCALE

PROJECT SERVICES UNIT
 STANDARDS AND SPECIAL DESIGN
 Office 919-250-4128 FAX 919-250-4119

**DETAIL OF OUTLET
 HAZARDOUS SPILL BASIN**

ORIGINAL BY: DATE:
 MODIFIED BY: iwdunneho DATE: 2-19-07
 CHECKED BY: DATE:
 FILE SPEC.: k4708_hazardous_spill_retention_basin.dgn

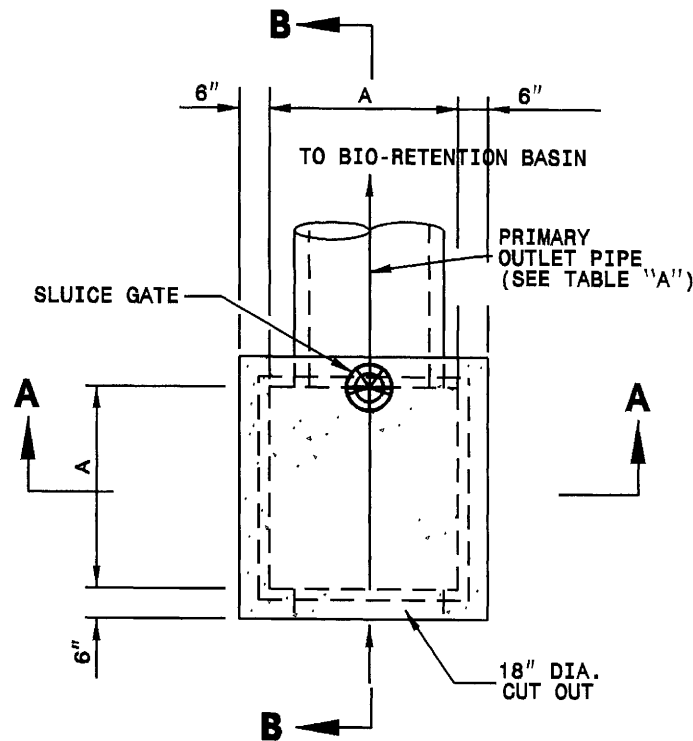

PLAN VIEW

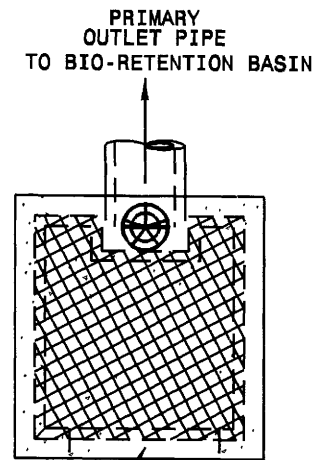

**TOP VIEW OF
RETICULINE FRAME AND
GRATE WITH SLUICE GATE**

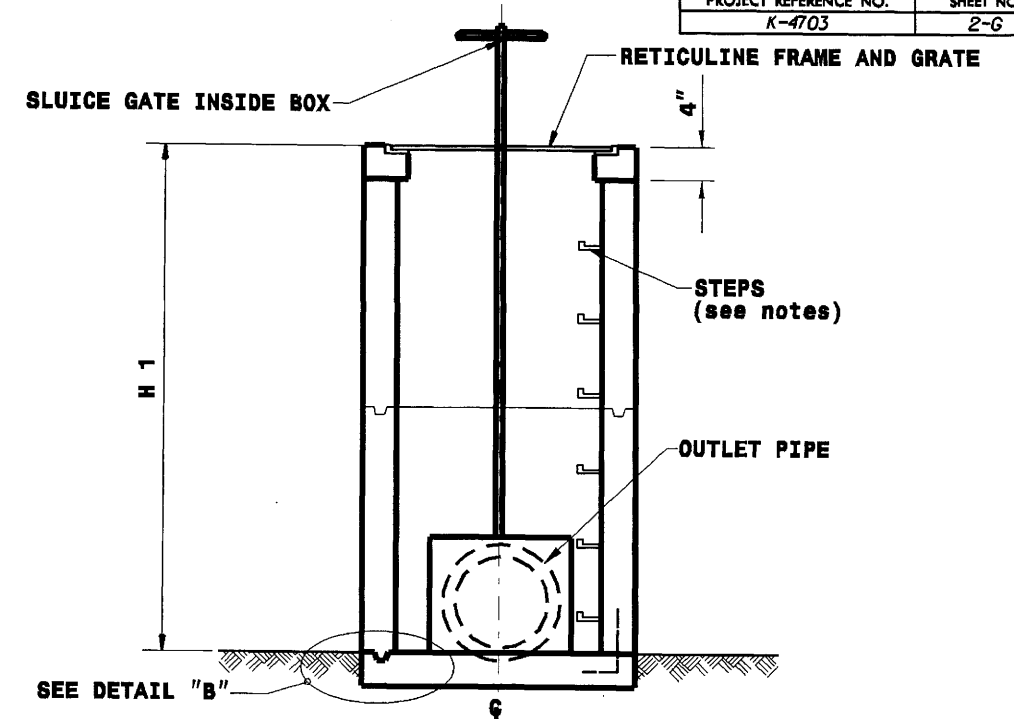

VIEW A-A

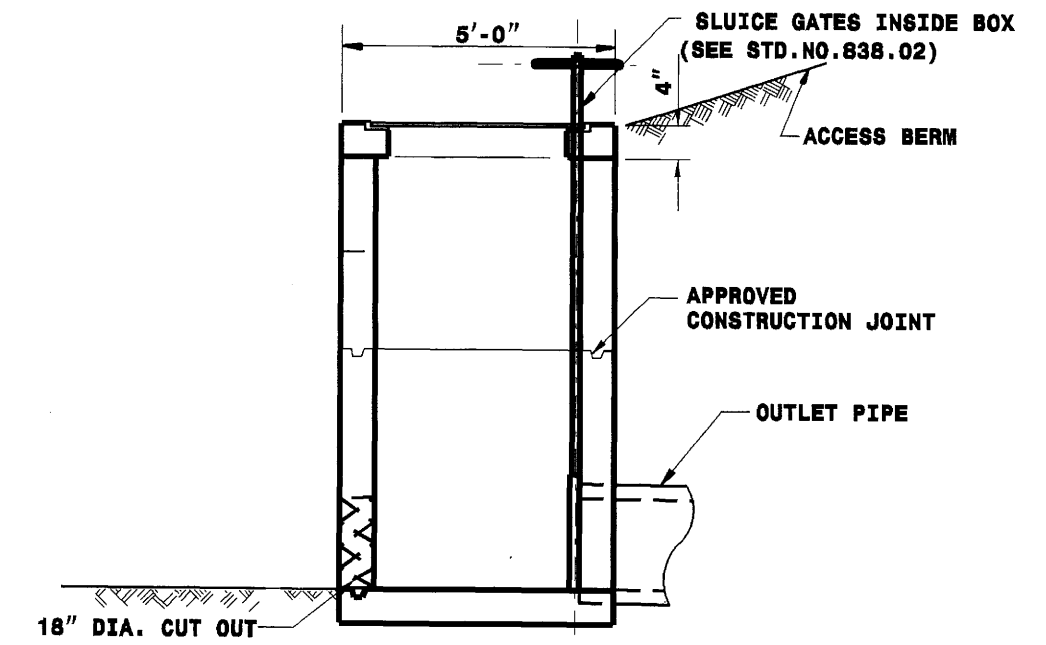

VIEW B-B

TABLE "A"

MINIMUM DIMENSIONS FOR OUTLET CONTROL STRUCTURE						
BASIN	OUTLET PIPE D	OUTLET PIPE INVERT	BOX PIPE HEIGHT H1	TOP OF GRATE ELEV.	18" CUT OUT INVERT	POOL BASIN ELEV.
Sta. 30+30-L2- (93'Lt)	18"	1126.0	3.0	1129.0	1126.0	1126.0

PIPE D	"A"	BARS-X		BARS-Y		"F"	TOTAL CONCRETE QUANTITIES
		QTY.	LENGTH	QTY.	LENGTH		
18"	4'-0"	6	6'-5"	6	6'-5"	5'-0"	1.9 CU.YDS.

GENERAL NOTES:

- * CHANGES IN ELEVATIONS MUST BE APPROVED BY THE ENGINEER.
- * CLASS 'B' CONCRETE TO BE USED THROUGHOUT. PRECAST CONCRETE STRUCTURES TO BE SUBMITTED FOR APPROVAL.
- * OPTIONAL CONSTRUCTION - MONOLITHIC POUR, 2 INCH KEYWAY, OR #4 BAR DOWELS AT 12 INCH CENTERS, AS DIRECTED BY THE ENGINEER.
- * FORMS ARE TO BE USED FOR THE CONSTRUCTION OF THE BOTTOM SLAB.
- * IF REINFORCED CONCRETE PIPE IS SET IN BASE SLAB OF BOX, ADD TO BASE AS SHOWN ON STANDARD 840.00.
- * ALL DRAWDOWN STRUCTURES OVER 3 FEET IN DEPTH TO BE PROVIDED WITH STEPS 12 INCH ON CENTERS. STEPS SHALL BE INSTALLED IN ACCORDANCE WITH STANDARD 840.66.
- * FOR 8'-0" IN HEIGHT OR LESS USE 8 INCH WALLS AND BOTTOM SLAB. OVER 8'-0" IN HEIGHT USE 12" WALLS TO 6'-0" FROM TOP OF WALL AND USE 8 INCH THICK WALLS FOR THE REMAINING 6'-0". ADJUST QUANTITIES ACCORDINGLY
- * RETICULINE FRAME AND GRATE TO BE APPROVED BY THE ENGINEER..

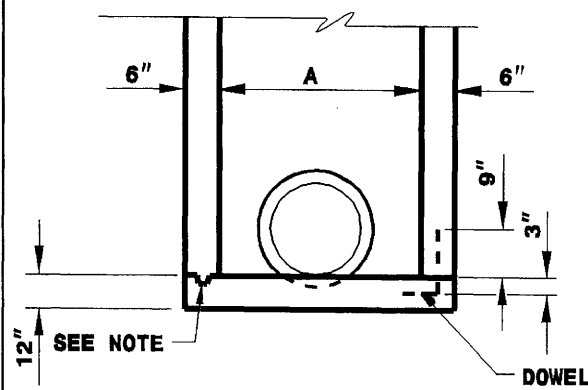

DETAIL 'B'

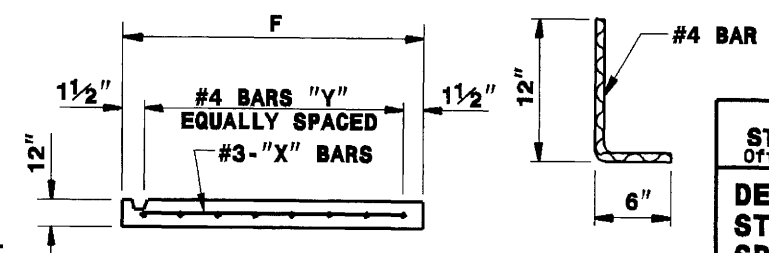

BOTTOM SLAB

DOWEL

**PROJECT SERVICES UNIT
STANDARDS AND SPECIAL DESIGN**
Office 919-260-4128 FAX 919-260-4119

**DETAIL OF OUTLET CONTROL
STRUCTURE FOR HAZARDOUS
SPILL BASIN**

ORIGINAL BY: _____ DATE: _____
 MODIFIED BY: jwdunneho DATE: 2-19-07
 CHECKED BY: _____ DATE: _____
 FILE SPEC.: k4703_hazardous_spill_retention_basin.dgn

10-APR-2007 11:20
 C:\Users\jwdunneho\4703-rdy-2f-g.dgn
 USER: jwdunneho

MATERIALS

A	200 ST GEOTEXTILE FABRIC
B	POLYPROPYLENE WOVEN MONOFILAMENT GEOTEXTILE FABRIC
C	
D	24" RCP INLET PIPE
E	24" RCP OUTFALL PIPE
F	6" PERFORATED HDPE D/W W/ FILTER SOCK
G	6" HDPE N12 D/W SOLID CLEANOUT PIPE
H	PRECAST DI BOX (SEE BOX SUMMARY)
I	ENGINEERED SOIL (SAND 70%, EXCAVATED MATERIAL 30%)
J	12 MONTH AGED HARDWOOD MULCH
K	CLASS B RIP RAP
L	WASH STONE NO. 57 AS PER NCDOT SPEC.

BASIN	UNDERDRAIN DIMENSIONS		FILTER BED DIMENSIONS	
	SPACING(u1)	LENGTH(u2)	WIDTH(f1)	LENGTH(f2)
WESTBOUND	24 FT.	VAR.	VAR.	VAR.

TABLE "A"

NOTE:
SEE PLAN SHEET #5 FOR SHAPE AND SIZE OF BASIN AND LENGTH OF UNDERDRAIN PIPES.
ENGINEERED SOIL SURFACE AREA AT ELEV. 1125.5 = 12094 SF.

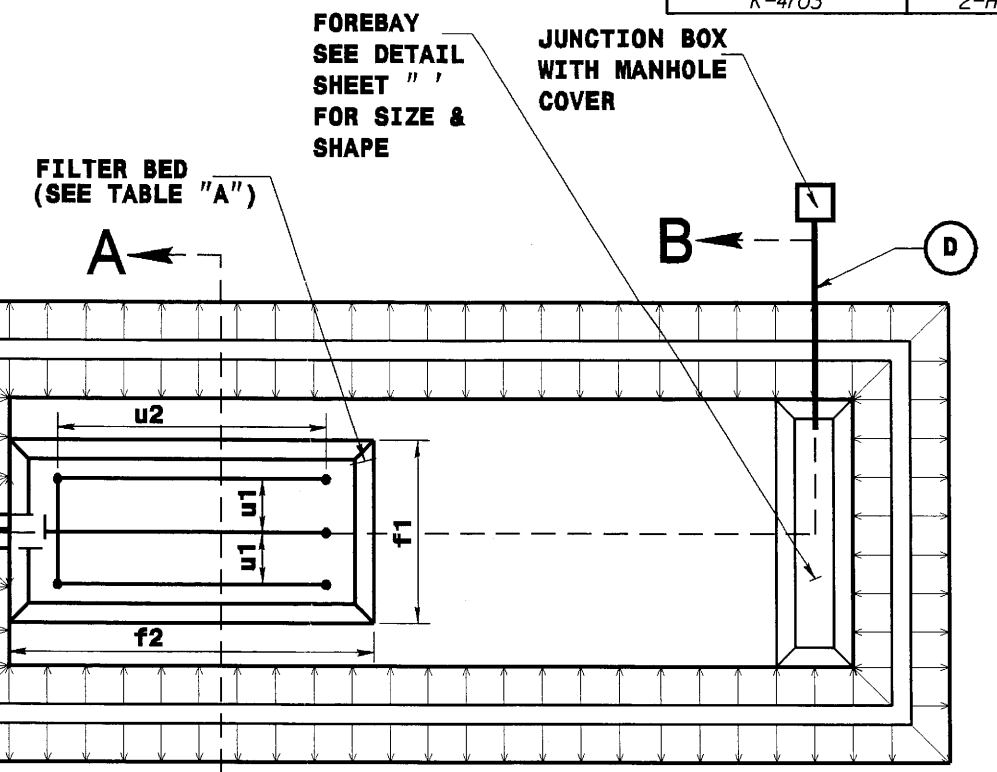

BIO-RETENTION DETAIL

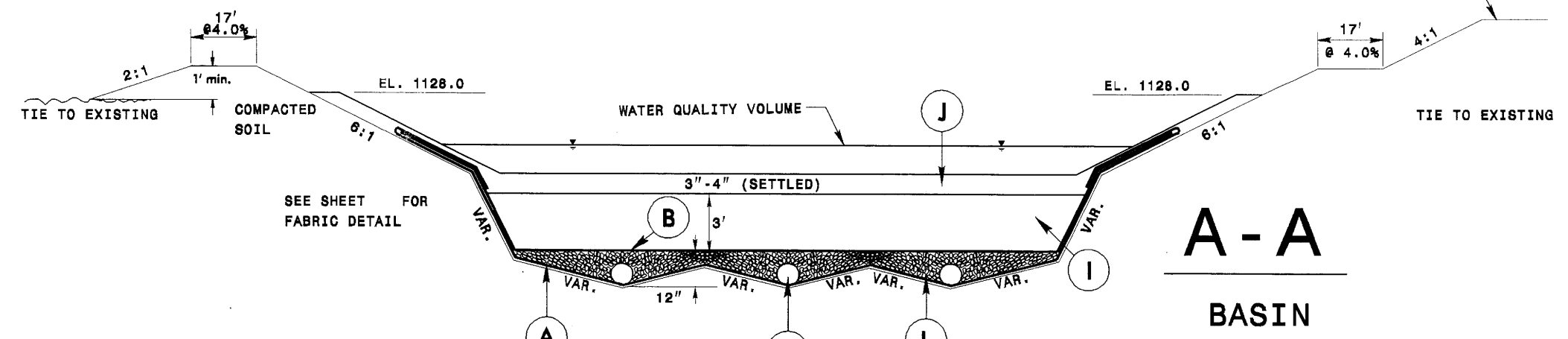

- NOTES**
- ENTIRE BASIN AND SEDIMENT FOREBAY WILL BE LINED WITH FILTER FABRIC (TYPE 200ST).
 - BASIN AND FOREBAY DIMENSIONS WILL VARY (AS DIRECTED BY THE ENGINEER).
 - PRECAST BOX DIMENSIONS WILL BE DETERMINED BY THE ENGINEER.

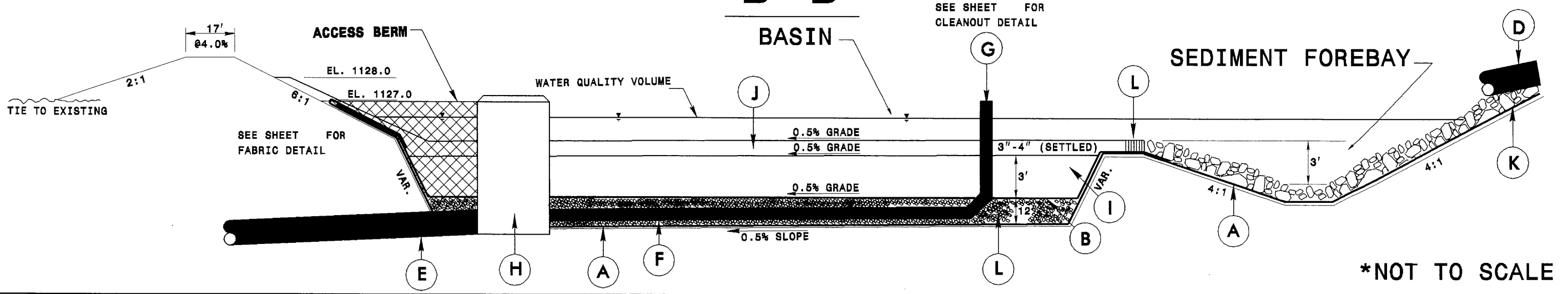

*NOT TO SCALE

10-APR-2007 11:20 \\s\proj\k4703_rdy_2h.dgn

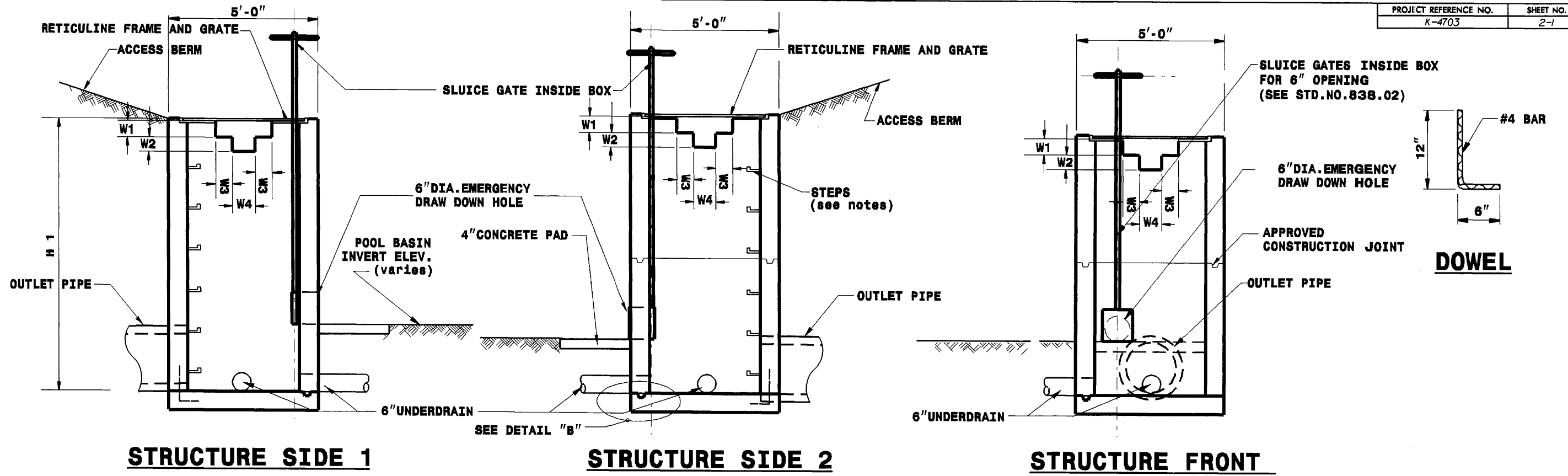

STRUCTURE SIDE 1

STRUCTURE SIDE 2

STRUCTURE FRONT

TABLE "A"

MINIMUM DIMENSIONS FOR OUTLET CONTROL STRUCTURE												
BASIN	PIPE D	OUTLET BOX PIPE HEIGHT INVERT H1	TOP OF GRATE ELEV.	UNDER DRAIN INVERT	ORFICE PLATE OPENING INVERT	POOL BASIN ELEV. @ PAD ELEV.	WEIR DIMENSIONS					
							W1	W2	W3	W4	W1 EL	W2 EL
Sta. 33+18-L2- (174 Lt)	24"	1120.27'	6.56'	1126.83'	1120.52'	1124.61'	0.50'	0.50'	0.90'	1.20'	1125.5'	1126.0'

PIPE D	"A"	BARS-X		BARS-Y		"F"	TOTAL CONCRETE QUANTITIES
		QTY.	LENGTH	QTY.	LENGTH		
24"	4'-0"	6	6'-5"	6	6'-5"	5'-0"	4.4 CU.YDS.

GENERAL NOTES:

- * CHANGES IN ELEVATIONS MUST BE APPROVED BY THE ENGINEER.
- * CLASS 'B' CONCRETE TO BE USED THROUGHOUT. PRECAST CONCRETE STRUCTURES TO BE SUBMITTED FOR APPROVAL.
- * OPTIONAL CONSTRUCTION - MONOLITHIC POUR, 2 INCH KEYWAY, OR #4 BAR DOWELS AT 12 INCH CENTERS, AS DIRECTED BY THE ENGINEER.
- * FORMS ARE TO BE USED FOR THE CONSTRUCTION OF THE BOTTOM SLAB.
- * IF REINFORCED CONCRETE PIPE IS SET IN BASE SLAB OF BOX, ADD TO BASE AS SHOWN ON STANDARD 840.00.
- * ALL DRAWDOWN STRUCTURES OVER 3 FEET IN DEPTH TO BE PROVIDED WITH STEPS 12 INCH ON CENTERS. STEPS SHALL BE INSTALLED IN ACCORDANCE WITH STANDARD 840.66.
- * FOR 8'-0" IN HEIGHT OR LESS USE 8 INCH WALLS AND BOTTOM SLAB. OVER 8'-0" IN HEIGHT USE 12" WALLS TO 6'-0" FROM TOP OF WALL AND USE 8 INCH THICK WALLS FOR THE REMAINING 6'-0". ADJUST QUANTITIES ACCORDINGLY
- * RETICULINE FRAME AND GRATE TO BE APPROVED BY THE ENGINEER..

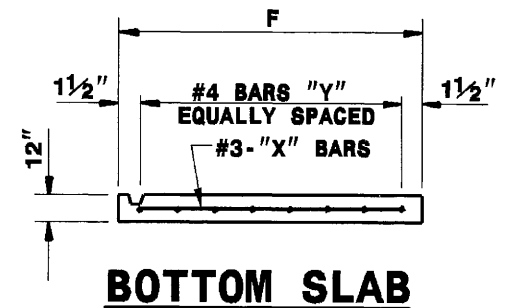
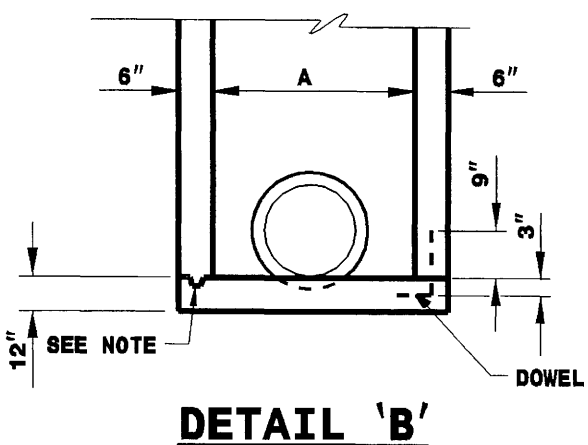

**PROJECT SERVICES UNIT
STANDARDS AND SPECIAL DESIGN**
Office 919-250-4128 FAX 919-250-4119

**DETAIL OF OUTLET CONTROL
STRUCTURE FOR
BIO-RETENTION BASIN**

ORIGINAL BY: _____ DATE: _____
 MODIFIED BY: jwdunneho DATE: 2-19-07
 CHECKED BY: _____ DATE: _____
 FILE SPEC: c:\hydraulics\k4703 bio-retention typ.dgn

10-APR-2007 11:20
 F:\projects\k4703\rdj_2h_1.dgn
 \$\$\$USERNAME\$\$\$

PROJECT REFERENCE NO. K-4703	SHEET NO. 4
RW SHEET NO.	
ROADWAY DESIGN ENGINEER	HYDRAULICS ENGINEER
PRELIMINARY PLANS DO NOT USE FOR CONSTRUCTION	
INCOMPLETE PLANS DO NOT USE FOR R/W ACQUISITION	

-L2- SPIRAL DATA
 Pls Sta 26+51.65
 Os = 14 19' 26.2"
 Ls = 200.00'
 LT = 133.77'
 ST = 67.07'

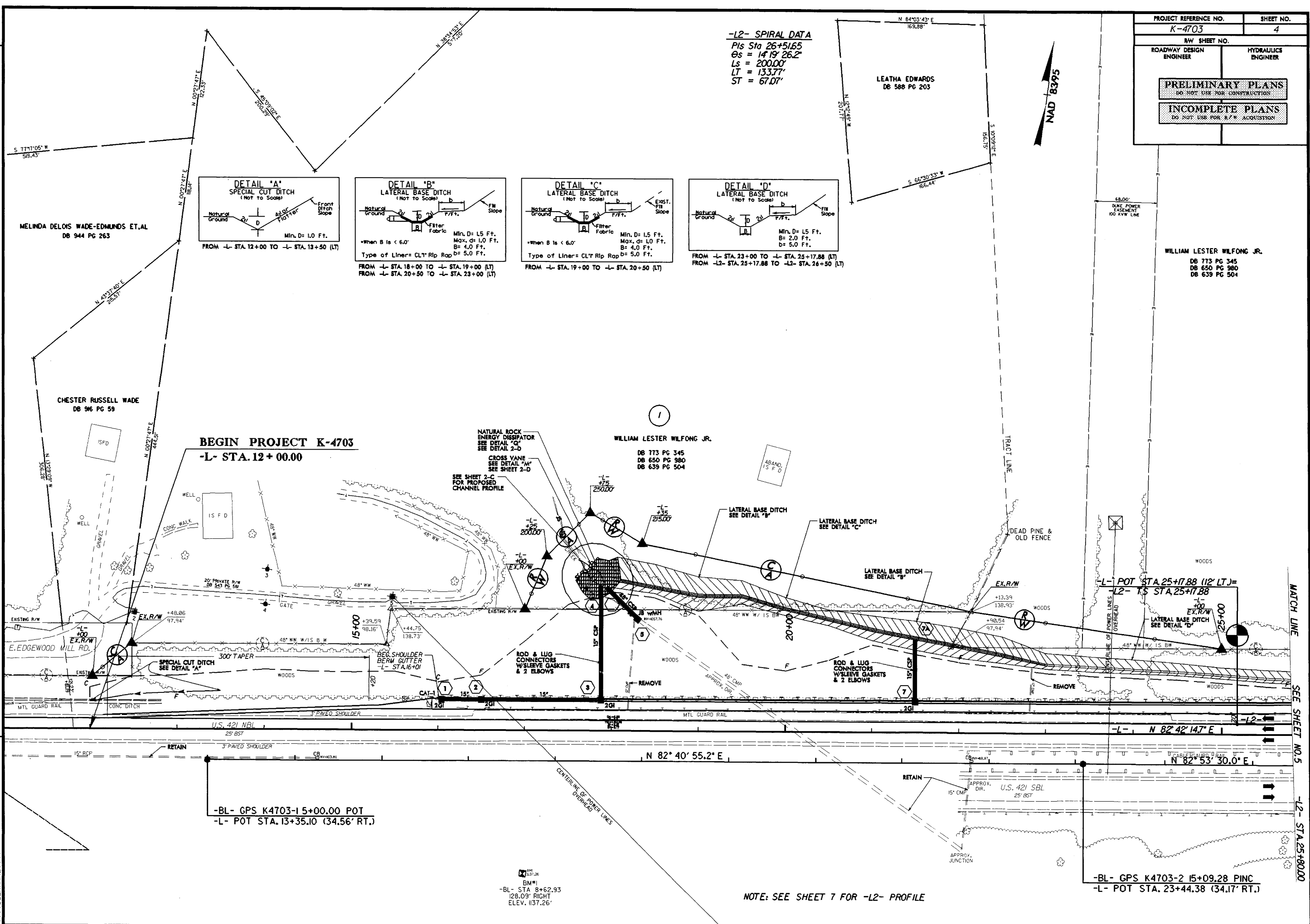
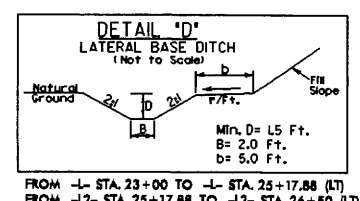
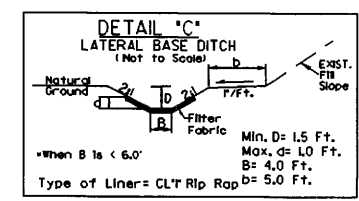
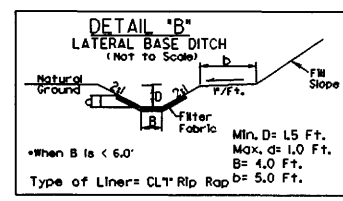
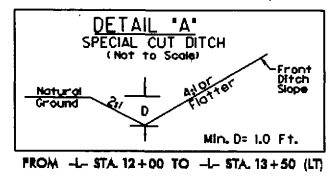

-BL- GPS K4703-1 5+00.00 POT
 -L- POT STA. 13+35.10 (34.56' RT.)

-BL- GPS K4703-2 15+09.28 PINC
 -L- POT STA. 23+44.38 (34.17' RT.)

NOTE: SEE SHEET 7 FOR -L2- PROFILE

10-APR-2007 11:12
 C:\p08\proj\k4703_rdy_psh4.dgn
 \$\$\$\$SUSSEMAN\$\$\$

BM#1
 -BL- STA 8+62.93
 (28.09' RIGHT
 ELEV. 1137.26'

REVISIONS

MATCH LINE
 SEE SHEET NO. 5
 -L2- STA. 25+80.00

PROJECT REFERENCE NO. K-4703	SHEET NO. 5
R/W SHEET NO.	
ROADWAY DESIGN ENGINEER	HYDRAULICS ENGINEER
PRELIMINARY PLANS DO NOT USE FOR CONSTRUCTION	
INCOMPLETE PLANS DO NOT USE FOR R/W ACQUISITION	

-L2- CURVE DATA

Pis Sta 26+51.65 Pi Sta 28+38.88
 Es = 14'19" 26.2" Δ = 33' 39" 40.9" (LT)
 Ls = 200.00' D = 14'19" 26.2"
 LT = 133.77' L = 235.00'
 ST = 61.07' T = 121.00'
 R = 400.00'
 SE = SEE PLANS

Pis Sta 30+19.95 Pi Sta 43+85.09
 Es = 14'19" 26.2" Δ = 94' 49" 57.9" (LT)
 Ls = 200.00' D = 38' 11" 49.9"
 LT = 133.77' L = 248.27'
 ST = 61.07' T = 163.22'
 R = 150.00'
 SE = SEE PLANS

Pis Sta 46+98.15 Pi Sta 47+03.49
 Δ = 163' 39" 27.7" (RT) Δ = 12' 09" 42.6" (RT)
 D = 35' 48" 35.5" D = 4' 46" 28.7"
 L = 457.02' L = 254.72'
 T = 114.30' T = 127.84'
 R = 160.00' R = 1,200.00'
 SE = SEE PLANS SE = SEE PLANS

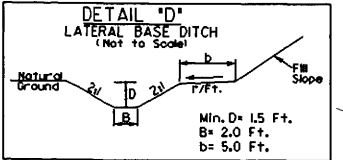

FROM -L- STA. 23+50 TO -L- STA. 23+17.88 (LT)
FROM -L2- STA. 23+17.88 TO -L2- STA. 26+50 (LT)

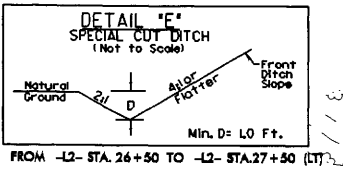

FROM -L2- STA. 26+50 TO -L2- STA. 27+50 (LT)

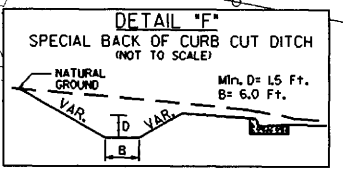

FROM -L2- STA. 30+00 TO -L2- STA. 35+00 (RT)
SEE PROP. CROSS SECTIONS FOR FRONT AND REAR SLOPES

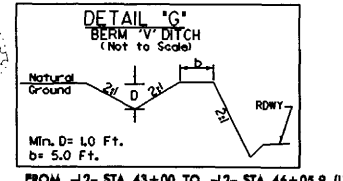

FROM -L2- STA. 43+00 TO -L2- STA. 46+05.9 (LT)

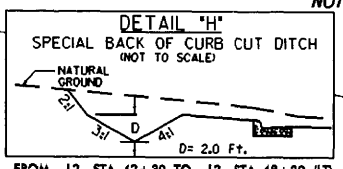

FROM -L2- STA. 42+30 TO -L2- STA. 48+30 (LT)

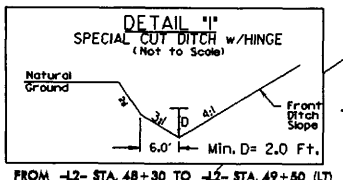

FROM -L2- STA. 48+30 TO -L2- STA. 49+50 (LT)

NOTES: (1) SEE SHEETS 8 & 9 FOR -L2- PROFILE
(2) SEE SHEET 10 FOR -TR-ON- & -TR-OFF- PROFILES

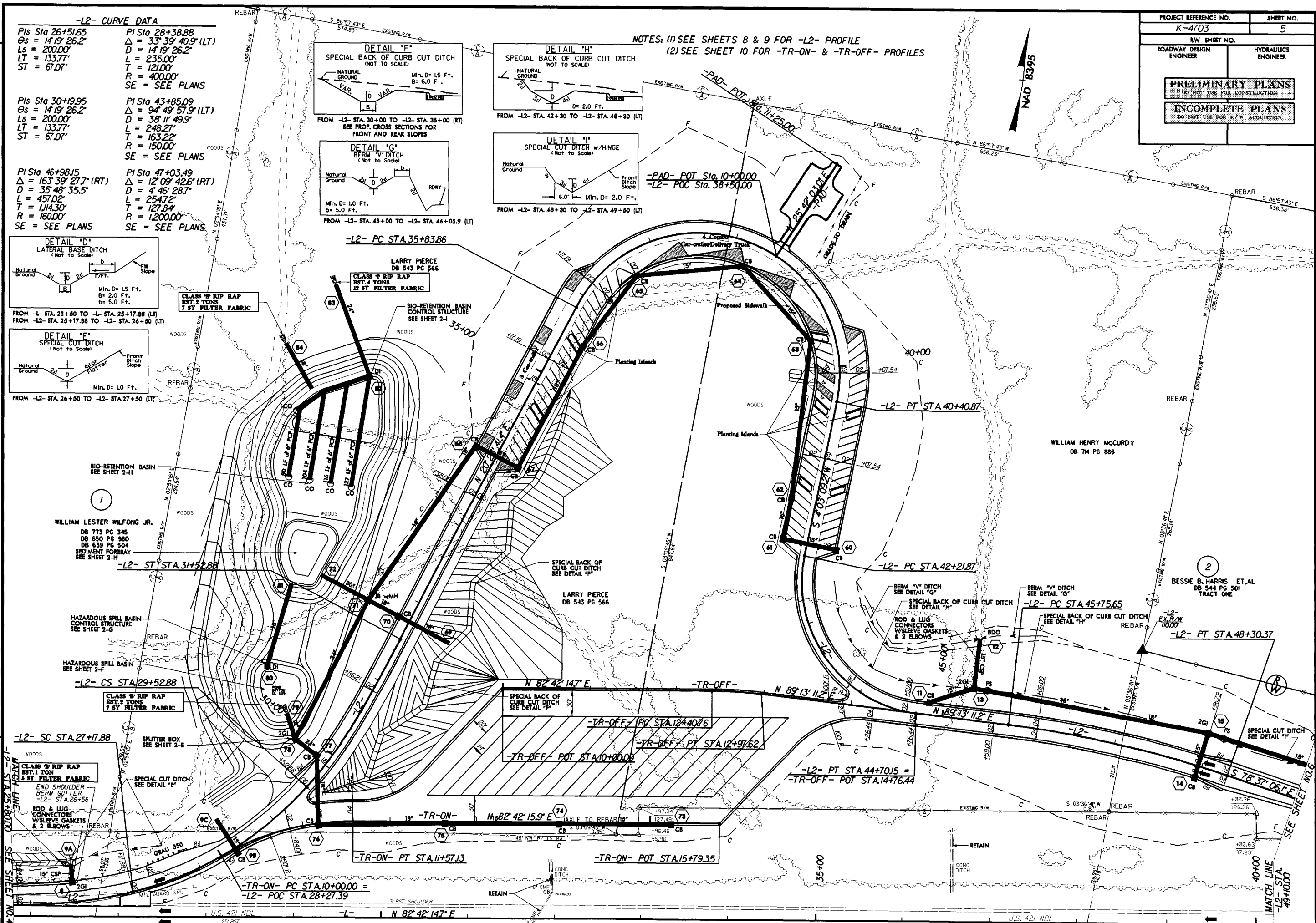

REVISIONS

10-APR-2007 lit2
K:\4703\104703.rdw-psh5.dgn
K:\4703\104703.rdw-psh5.dgn

MATCH LINE
-L2- STA. 49+1000
SEE SHEET NO. 6

MATCH LINE
-L2- STA. 25+8000
SEE SHEET NO. 4

PROJECT REFERENCE NO. K-4703	SHEET NO. 5-A
ROADWAY DESIGN ENGINEER	HYDRAULICS ENGINEER
PRELIMINARY PLANS DO NOT USE FOR CONSTRUCTION	
INCOMPLETE PLANS DO NOT USE FOR R/W ACQUISITION	

WILLIAM HENRY MCGURDY

BESSIE B. HARRIS ET AL

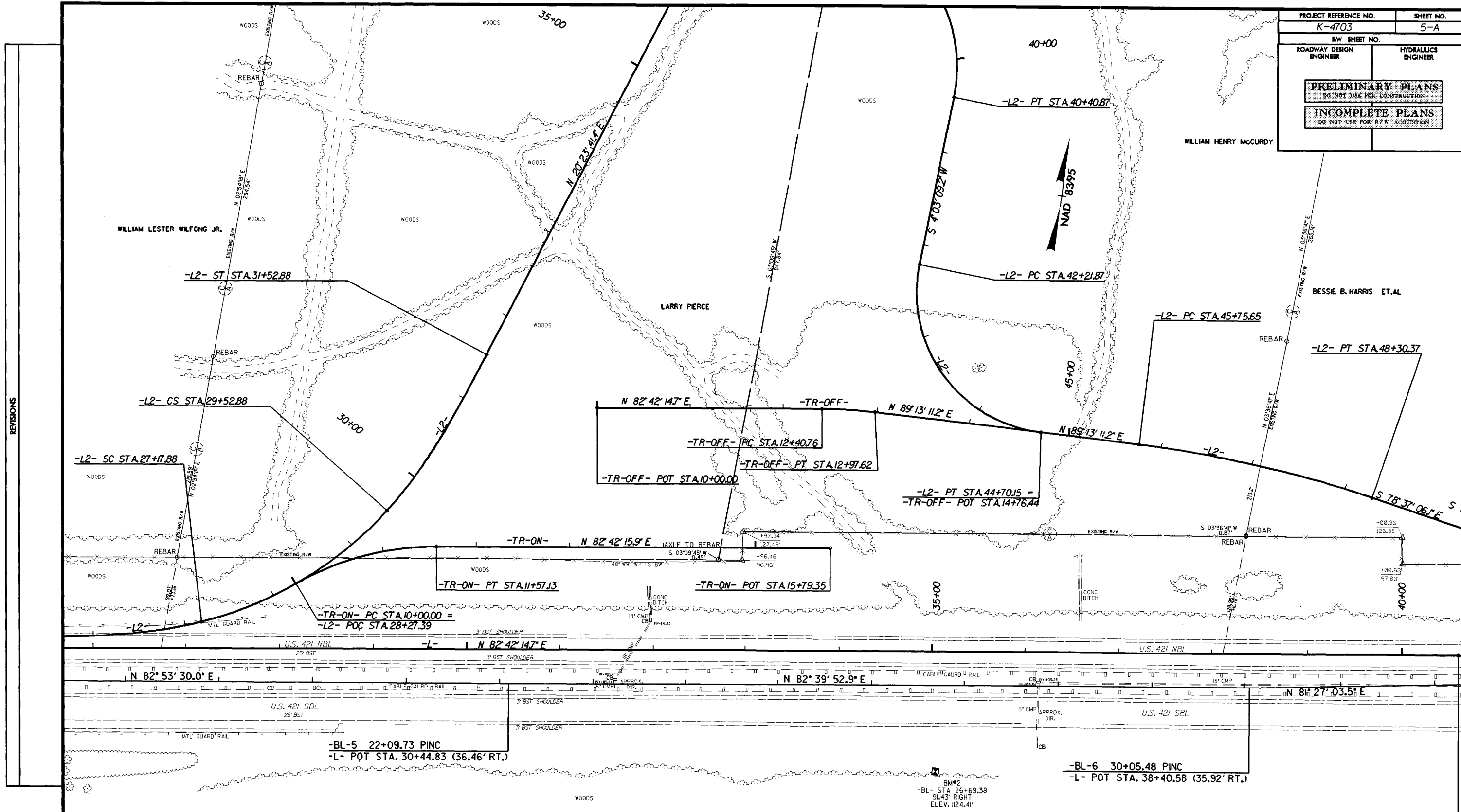

REVISIONS

-L2- CURVE DATA		
PI Sta 26+51.65 Δ = 14° 19' 26.2" D = 200.00' LT = 133.77' ST = 67.07'	PI Sta 28+38.88 Δ = 33° 39' 40.9" (LT) D = 141° 19' 26.2" L = 235.00' T = 121.00' R = 400.00' SE = SEE PLANS	PI Sta 30+19.95 Δ = 14° 19' 26.2" D = 200.00' LT = 133.77' ST = 67.07'
PI Sta 43+85.09 Δ = 94° 49' 57.9" (LT) D = 36° 11' 49.9" L = 248.27' T = 163.22' R = 150.00'	PI Sta 46+98.15 Δ = 163° 39' 27.7" (RT) D = 35° 48' 35.5" L = 457.02' T = 114.30' R = 160.00' SE = SEE PLANS	PI Sta 47+03.49 Δ = 12° 09' 42.6" (RT) D = 4° 46' 28.7" L = 254.72' T = 127.84' R = 1,200.00'

-TR-ON- CURVE DATA	-TR-OFF- CURVE DATA
PI Sta 10+80.41 Δ = 30° 00' 37.0" (RT) D = 19° 05' 54.9" L = 157.13' T = 80.41' R = 300.00' SE = SEE PLANS	PI Sta 12+69.22 Δ = 6° 30' 56.5" (RT) D = 11° 27' 33.0" L = 56.86' T = 28.46' R = 500.00' SE = SEE PLANS

-BL-5 22+09.73 PINC
-L- POT STA. 30+44.83 (36.46' RT.)

-BL-6 30+05.48 PINC
-L- POT STA. 38+40.58 (35.92' RT.)

I:\APR-2007\112\N4703\p15a.dgn
6/6/07 11:21 AM

PROJECT REFERENCE NO. K-4703	SHEET NO. 6
RW SHEET NO.	
ROADWAY DESIGN ENGINEER	HYDRAULICS ENGINEER
PRELIMINARY PLANS DO NOT USE FOR CONSTRUCTION	
INCOMPLETE PLANS DO NOT USE FOR R/W ACQUISITION	

-L2- CURVE DATA

PIs Sta 51+77.4 Os = 4' 46" 28.7" Ls = 200.00' LT = 133.38' ST = 66.71'	PIs Sta 53+08.73 Δ = 11' 50" 06.5" (LT) D = 4' 46" 28.7" L = 247.87' T = 124.38' R = 1,200.00' SE = SEE PLANS	PIs Sta 55+04.80 Os = 0' 27" 30.0" Ls = 200.00' LT = 127.55' ST = 72.57'	PIs Sta 58+14.24 Δ = 1' 40" 12.3" (LT) D = 0' 27" 31.7" L = 364.01' T = 182.02' R = 12,488.00' SE = SEE PLANS
---	---	--	---

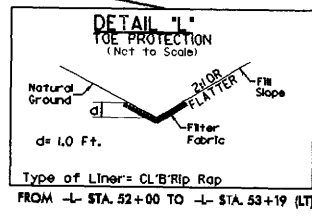
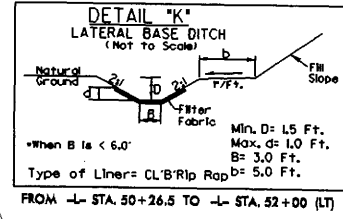
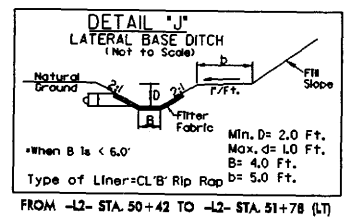
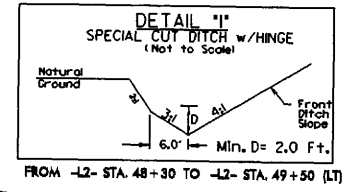

2
BESSIE B. HARRIS ET AL

3
JAMES WESLEY HARRIS

END PROJECT K-4703
-L- STA. 55 + 00.00

REVISIONS

10-APR-2007 11:21 AM K-4703-r.dj-psh6.dgn

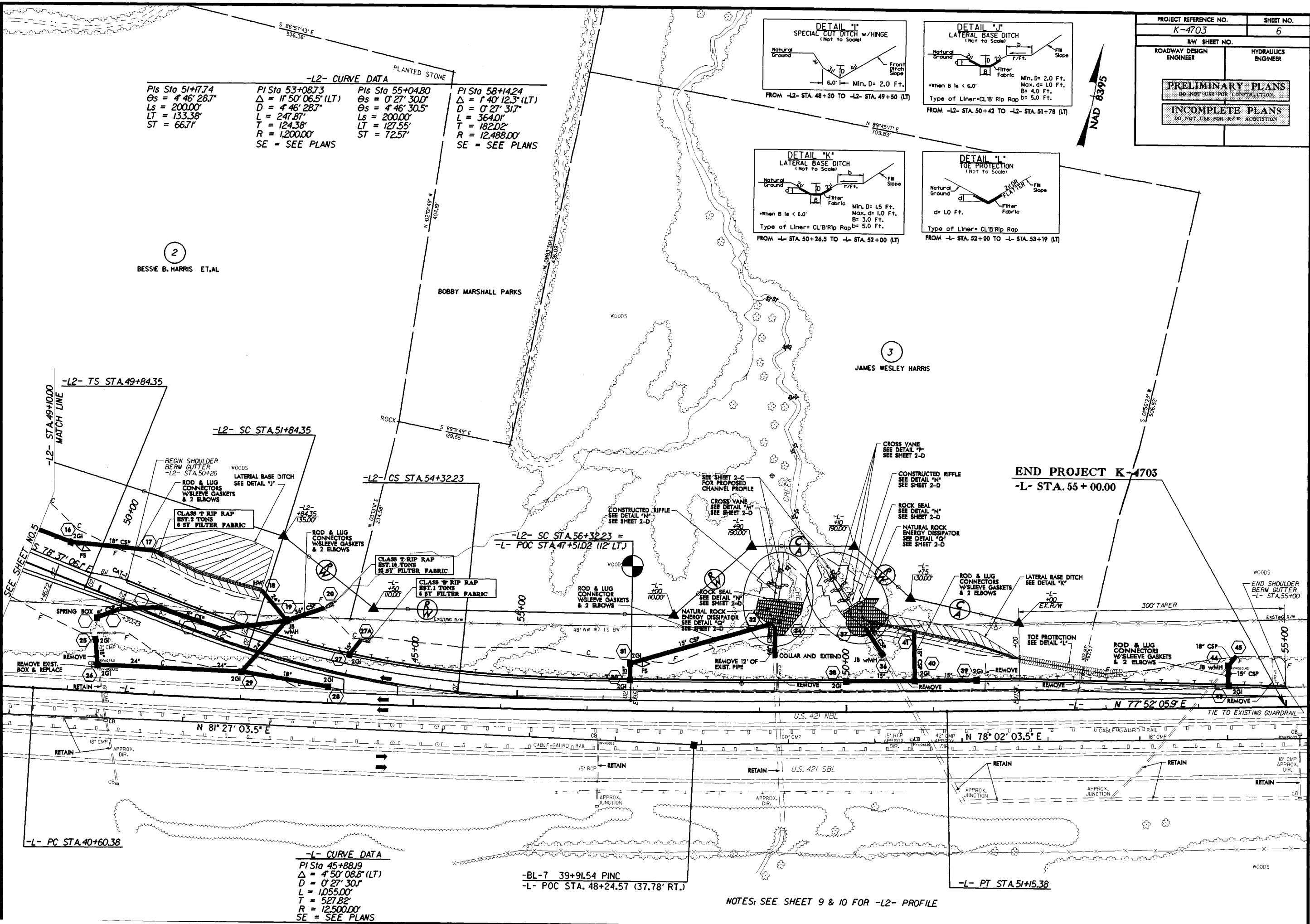

-L- CURVE DATA

PIs Sta 45+88.19 Δ = 4' 50" 08.8" (LT) D = 0' 27" 30.0" L = 1055.00' T = 527.82' R = 12,500.00' SE = SEE PLANS
--

-BL-7 39+91.54 PINC
-L- POC STA. 48+24.57 (37.78' RT.)

-L- PT STA. 51+15.38

NOTES: SEE SHEET 9 & 10 FOR -L2- PROFILE

5/14/99

C:\APR-2007\112\112\4703_r.dwg.p1.dgn

PROJECT REFERENCE NO. K-4703	SHEET NO. 7
ROADWAY DESIGN ENGINEER	HYDRAULICS ENGINEER
PRELIMINARY PLANS DO NOT USE FOR CONSTRUCTION	
INCOMPLETE PLANS DO NOT USE FOR R/W ACQUISITION	

BM #1 EL. 1137.26'
TOP OF R/W MON.
AT NE FENCE CORNER IN R/W FENCE
-BL- STA. 8+63 (128' RT)
-L- STA. 16+98.09 (162.5' RT)

-L-

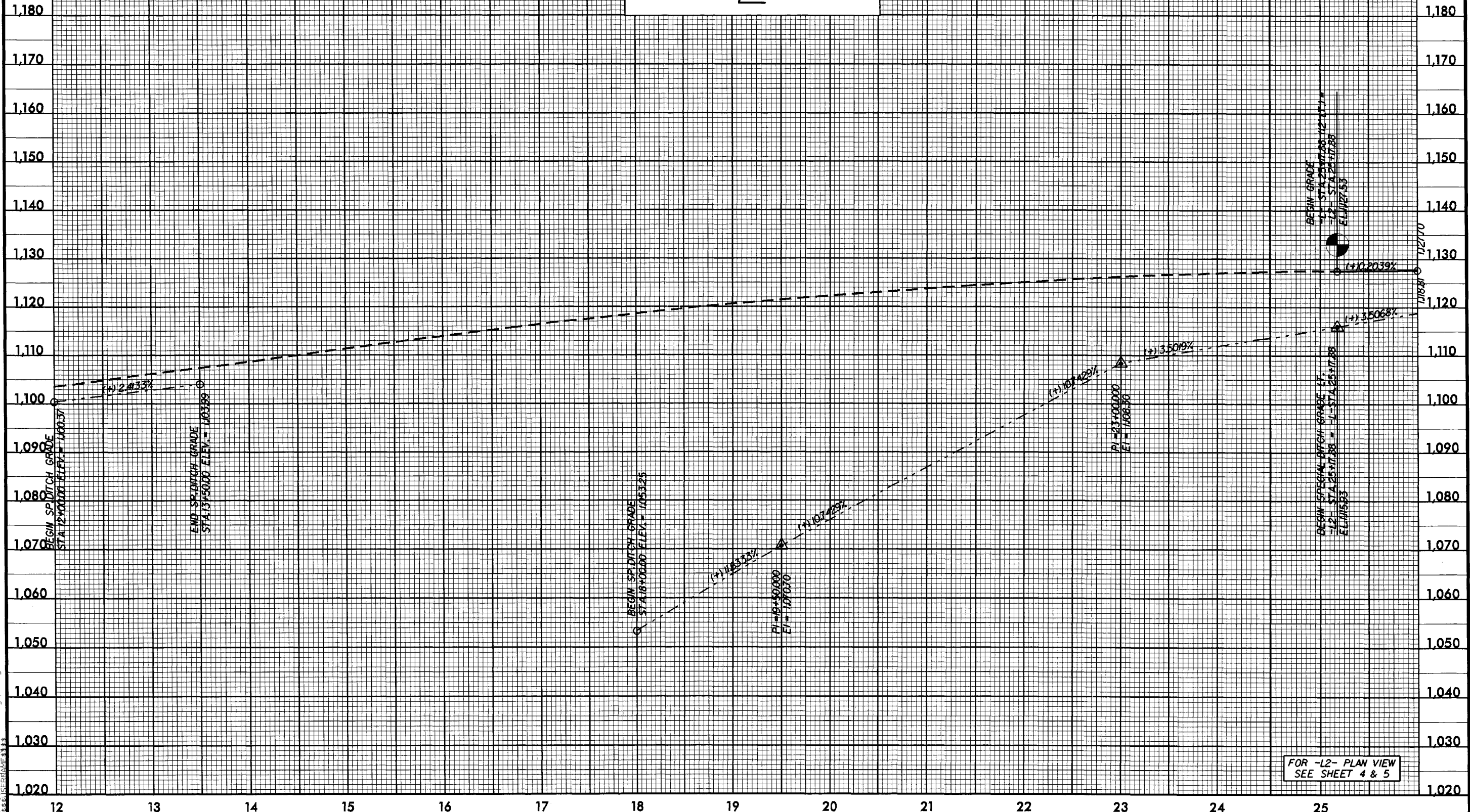

-L2-

PI = 41+50.00
 EL = 1,177.28'
 VC = 700'
 K = 64
 SSD = 372'

PI = 29+25.00
 EL = 1,128.36'
 VC = 480'
 K = 127

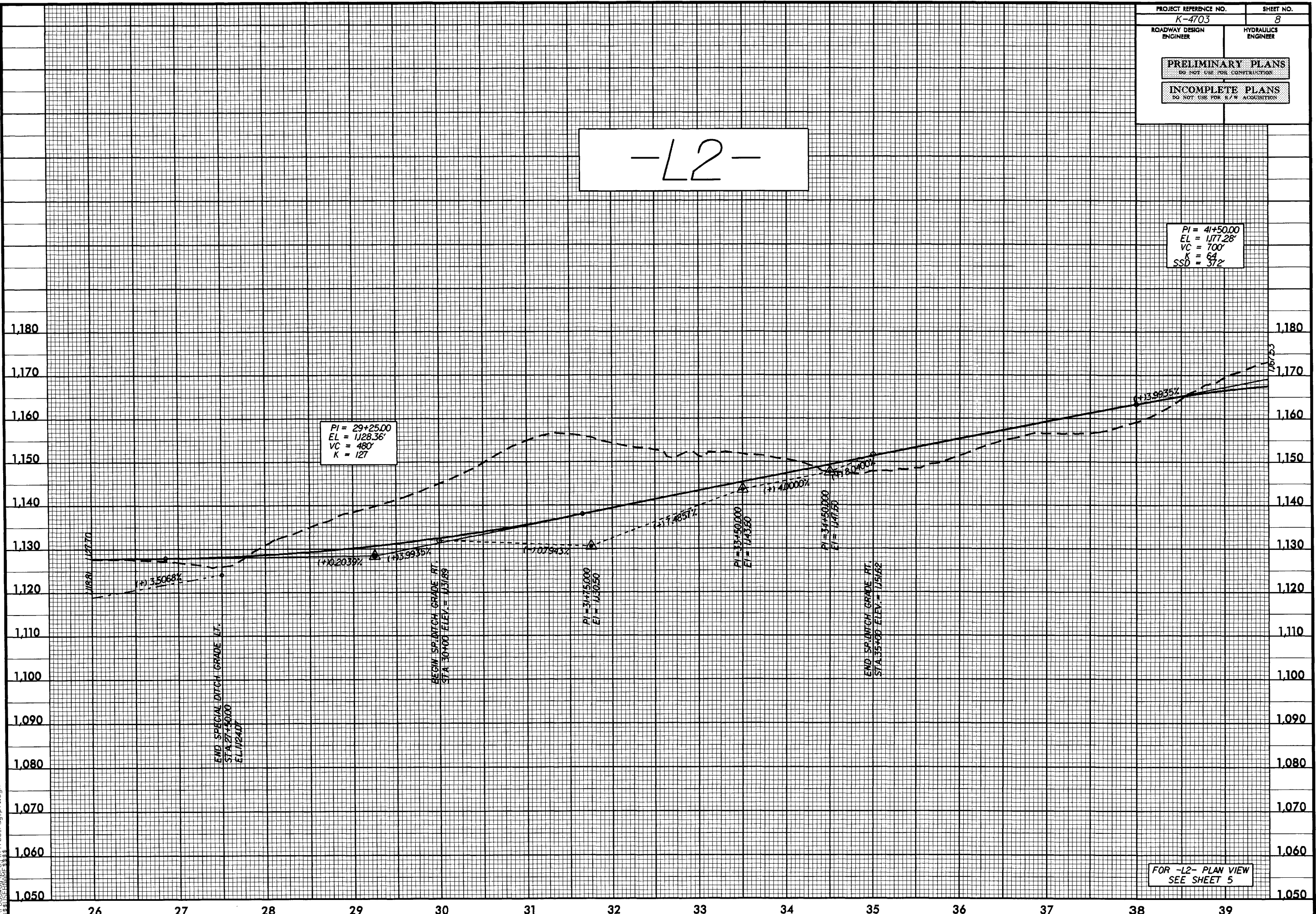

FOR -L2- PLAN VIEW
SEE SHEET 5

5/14/99
 J:\APR-2007\112\112\roadway\K-4703-rdy-pl.dgn
 112\112\roadway\K-4703-rdy-pl.dgn

-L2-

BM #2 EL 1121.41'
8" SPIKE IN BASE OF A 10' POPLAR TREE
-BL- STA. 26+69 (91' RT.)
-L- STA. 35+04.54 (127.58' RT.)
-L2- STA. 44+50.63 (178.73' RT.)

PI = 41+50.00
EL = 1177.28'
VC = 700'
K = 64
SSD = 372'

PI = 47+00.00
EL = 1139.07'
VC = 200'
K = 190
SSD = 1125'

PI = 51+35.00
EL = 1104.27'
VC = 580'
K = 87

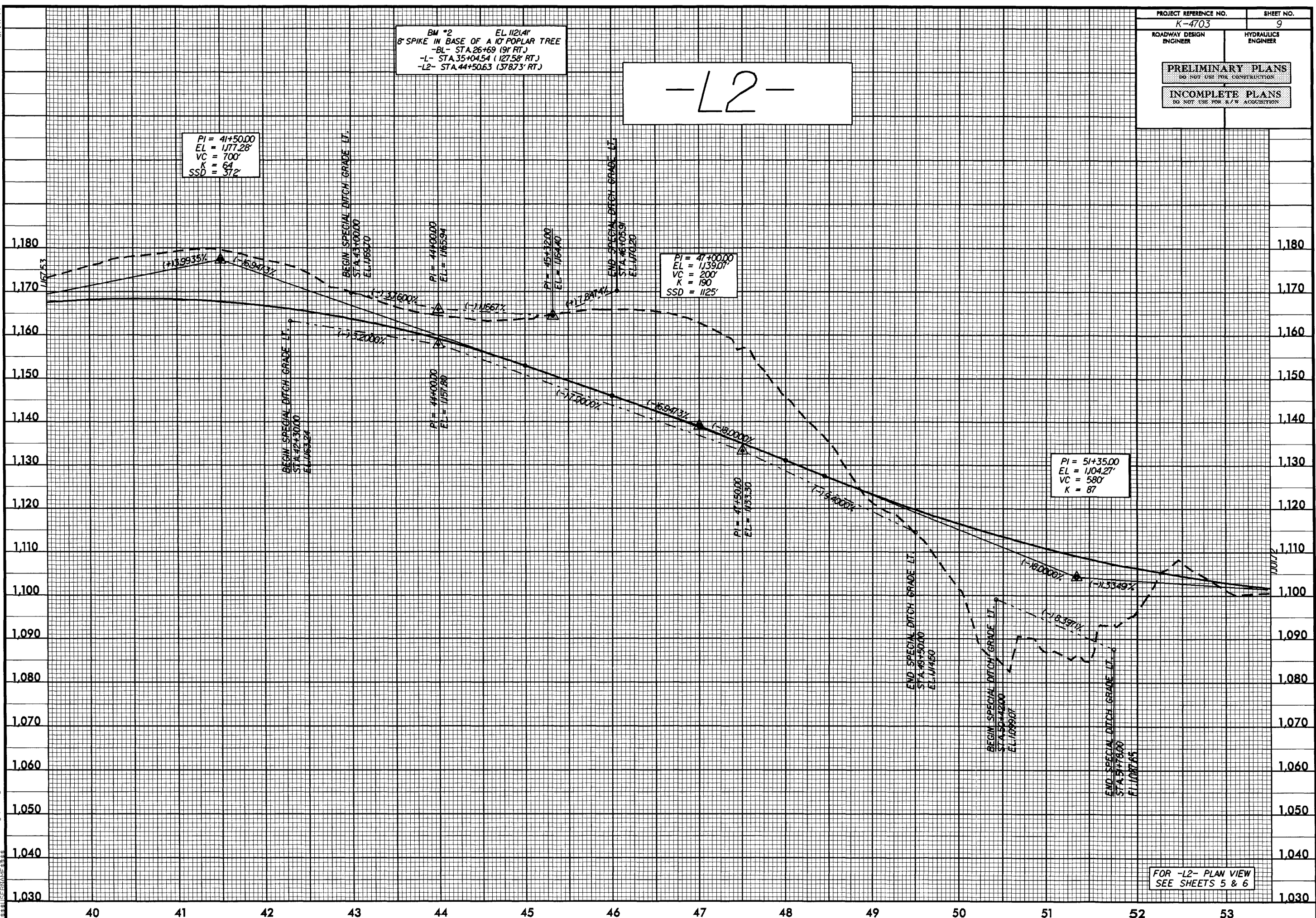

5/14/99

IG-APR-2007.mxd
K-4703_rdlj_pfl.dgn
5/14/99 10:58:58 AM

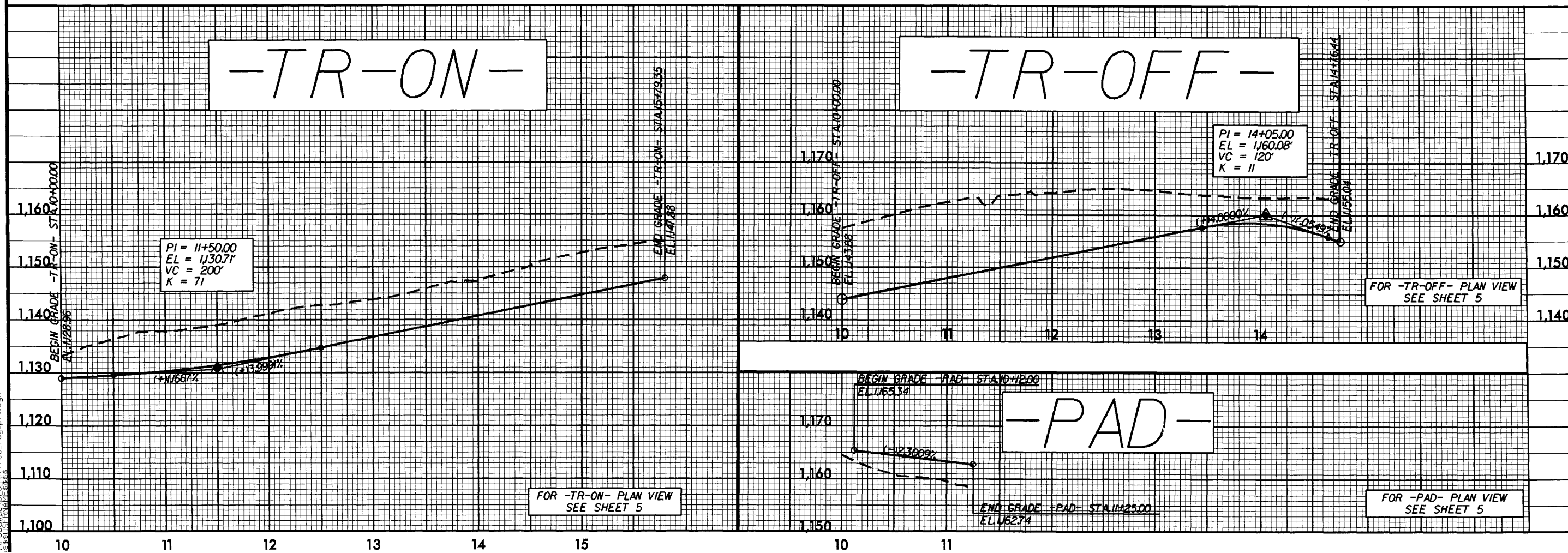
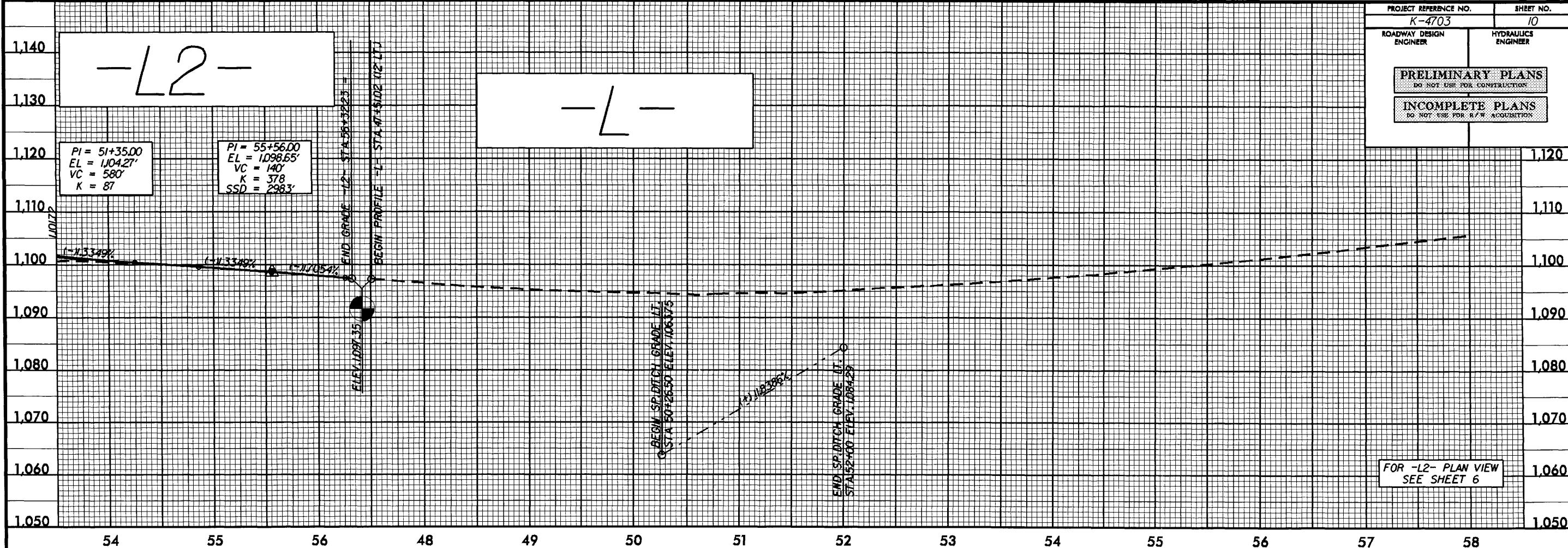

5/28/95
 2-APR-2007 11:12
 i:\projects\k4703\rdy-pf1.dgn