

09/08/19

TIP PROJECT: U-5768

See Sheet 1B For Conventional Symbols

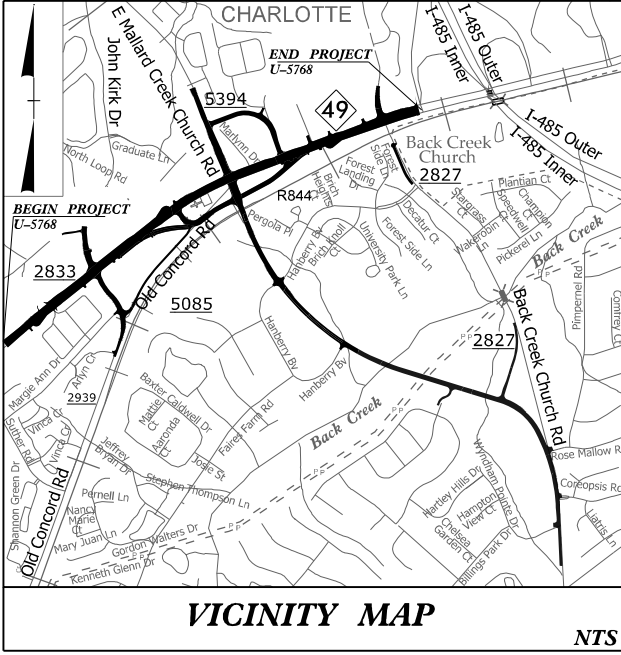

STATE OF NORTH CAROLINA
DIVISION OF HIGHWAYS

MECKLENBURG COUNTY

**LOCATION: NC 49 FROM JOHN KIRK DRIVE TO I-485
BACK CREEK CHURCH RD FROM WYNDHAM POINTE DR TO NC 49
TYPE OF WORK: GRADING, PAVING, DRAINAGE, STRUCTURES
RETAINING WALLS, AND SIGNALS**

STATE	STATE PROJECT REFERENCE NO.	SHEET NO.	TOTAL SHEETS
N.C.	U-5768	1	
STATE PROJ. NO.	F.A. PROJ. NO.	DESCRIPTION	
50181.1.R1		P.E.	

☆ EXISTING SIGNAL
★ PROPOSED SIGNAL

**CP4B Plans
9/15/2021**

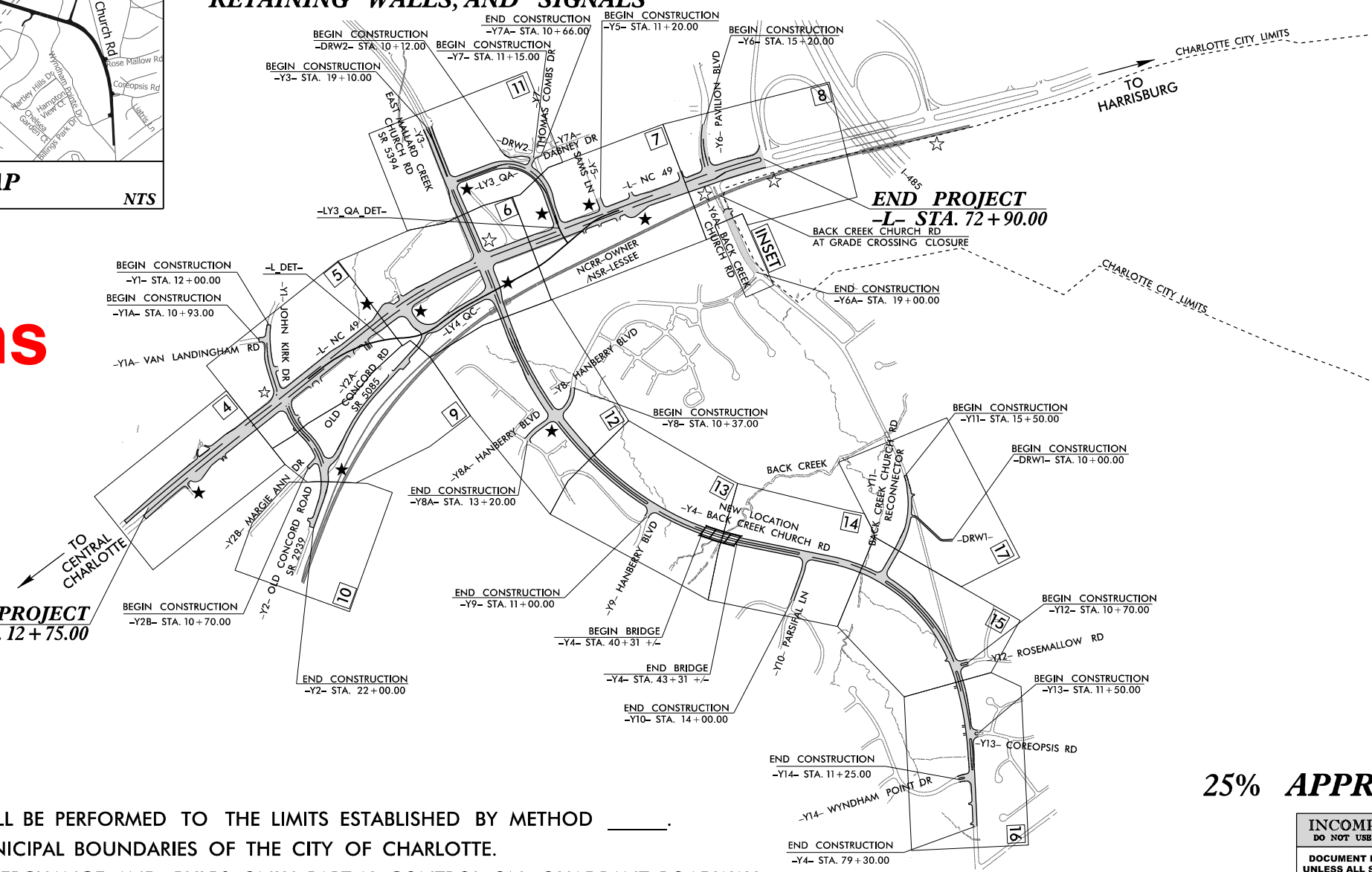

- NOTES:
- CLEARING ON THIS PROJECT SHALL BE PERFORMED TO THE LIMITS ESTABLISHED BY METHOD _____.
 - THIS PROJECT IS WITHIN THE MUNICIPAL BOUNDARIES OF THE CITY OF CHARLOTTE.
 - FULL CONTROL OF ACCESS AT INTERCHANGE AND BULBS ONLY. PARTIAL CONTROL ON QUADRANT ROADWAY.

25% APPROVED PLANS

INCOMPLETE PLANS
DO NOT USE FOR R/W ACQUISITION
DOCUMENT NOT CONSIDERED FINAL
UNLESS ALL SIGNATURES COMPLETED

CONTRACT:

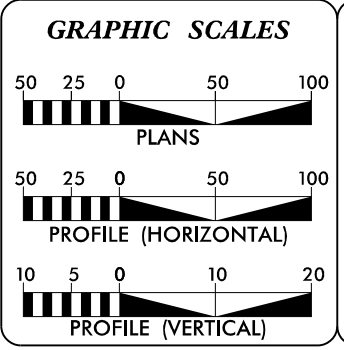

DESIGN DATA

ADT 2025 =	54,100
ADT 2045 =	70,900
K =	7 %
D =	70 %
T =	4 % *
V =	40 MPH
* TTST=1% DUAL=3%	
FUNC CLASS =	
PRINCIPAL ARTERIAL	
REGIONAL TIER	

PROJECT LENGTH

LENGTH OF ROADWAY T.I.P. PROJECT U-5768 =	1.139 MILES
TOTAL LENGTH OF T.I.P. PROJECT U-5768 =	1.139 MILES
ALL LENGTHS BASED ON -L- CENTERLINE	

PREPARED IN THE OFFICE OF:

HNTB HNTB NORTH CAROLINA, P.C.
101 S. Tryon Street, Suite 3610
Charlotte, North Carolina 28280
NC License No: C-1554

FOR THE DIVISION OF HIGHWAYS

RIGHT OF WAY DATE:
DECEMBER 17, 2021

LETTING DATE:
JULY 16, 2024

JEFF HESS, P.E.
PROJECT ENGINEER

BRIAN BLACKWELL, P.E.
PROJECT DESIGN ENGINEER

KRISTINA SOLBERG, PE
NCDOT CONTACT

HYDRAULICS ENGINEER

SIGNATURE: _____ P.E.

ROADWAY DESIGN ENGINEER

SIGNATURE: _____ P.E.

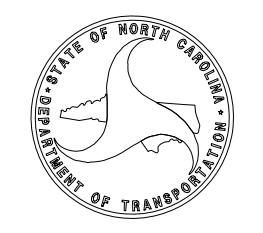

30-AUG-2021 09:56
N:\Roadway\Proj\U5768_RDY_TSH.dgn
HN1B

5/14/99

70-AUG-20(19)556
 3/20/05 (P.03) U5768.RDY_TYP.dgn

AWAITING FINAL PAVEMENT SCHEDULE	
C1	PROP. APPROX. 1.5" ASPHALT CONCRETE SURFACE COURSE, TYPE S9.5C, AT AN AVERAGE RATE OF 168 LBS. PER SQ. YD.
C2	PROP. APPROX. 3" ASPHALT CONCRETE SURFACE COURSE, TYPE S9.5C, AT AN AVERAGE RATE OF 168 LBS. PER SQ. YD. PLACED IN TWO LAYERS.
C3	PROP. VAR. DEPTH ASPHALT CONCRETE SURFACE COURSE, TYPE S9.5C, AT AN AVERAGE RATE OF 112 LBS. PER SQ. YD. PER 1" DEPTH, TO BE PLACED IN LAYERS NOT LESS THAN 1.5" IN DEPTH OR GREATER THAN 2" IN DEPTH.
D1	PROP. APPROX. 4" ASPHALT CONCRETE INTERMEDIATE COURSE, TYPE I19.0C, AT AN AVERAGE RATE OF 456 LBS. PER SQ. YD.
D2	PROP. VAR. DEPTH ASPHALT CONCRETE INTERMEDIATE COURSE, TYPE I19.0C, AT AN AVERAGE RATE OF 114 LBS. PER SQ. YD. PER 1" DEPTH, TO BE PLACED IN LAYERS NOT LESS THAN 2 1/2" IN DEPTH OR GREATER THAN 4" IN DEPTH.
E1	PROP. APPROX. 4" ASPHALT CONCRETE BASE COURSE, TYPE B25.0C, AT AN AVERAGE RATE OF 456 LBS. PER SQ. YD.
E2	PROP. APPROX. 7" ASPHALT CONCRETE BASE COURSE, TYPE B25.0C, AT AN AVERAGE RATE OF 399 LBS. PER SQ. YD. PLACED IN TWO LAYERS.
E3	PROP. VAR. DEPTH ASPHALT CONCRETE BASE COURSE, TYPE B25.0C, AT AN AVERAGE RATE OF 114 LBS. PER SQ. YD. PER 1" DEPTH, TO BE PLACED IN LAYERS NOT LESS THAN 3" IN DEPTH OR GREATER THAN 5 1/2" IN DEPTH.
J1	7" AGGREGATE BASE COURSE.
R1	2'-6" CONCRETE CURB AND GUTTER.
R2	1'-6" CONCRETE CURB AND GUTTER.
R3	2'-9" CONCRETE CURB AND GUTTER.
R4	5" MONOLITHIC CONCRETE ISLAND (KEYED IN).
S1	4" CONCRETE SIDEWALK.
T	EARTH MATERIAL.
U	EXISTING PAVEMENT.
V1	MILLING BITUMINOUS PAVEMENT 1.5".
V2	INCIDENTAL MILLING .
W	VARIABLE DEPTH ASPHALT PAVEMENT. (SEE DETAIL NO. 1 SHOWING METHOD OF WEDGING)

NOTE: PAVEMENT EDGE SLOPES ARE 1:1 UNLESS SHOWN OTHERWISE.

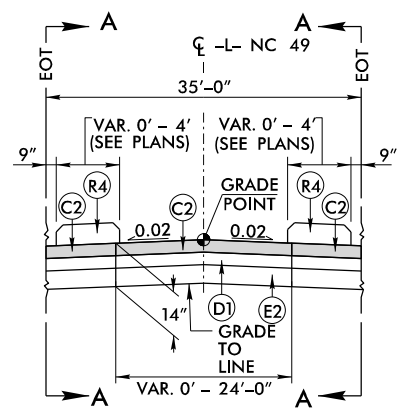

DETAIL 1A
 MONOLITHIC ISLAND LOCATIONS
 USE IN CONJUNCTION WITH TYPICAL SECTION 1 & 2

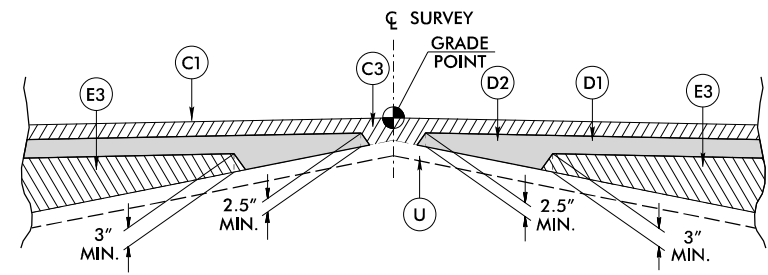

DETAIL SHOWING METHOD OF WEDGING NO.1

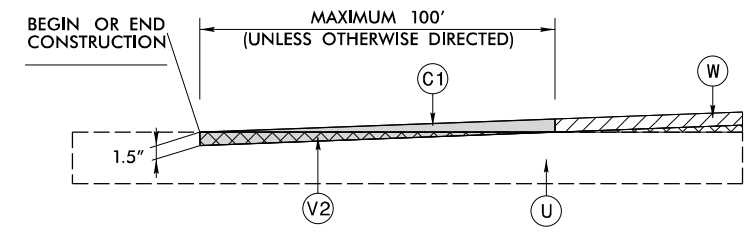

INCIDENTAL MILLING DETAIL
 TO BE USED AT ALL TIE-IN LOCATIONS
 MIRROR FOR OPPOSITE DIRECTION

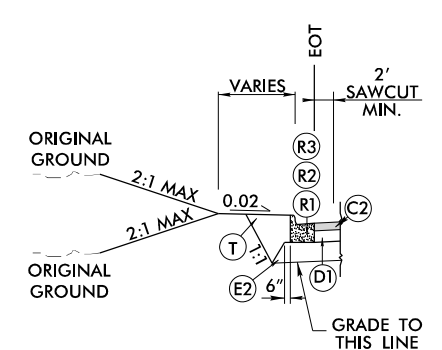

CONCRETE CURB SAWCUT DETAIL
 ALL CURBING LOCATIONS
 MIRROR FOR OPPOSITE DIRECTION
 SEE PLANS FOR LOCATIONS

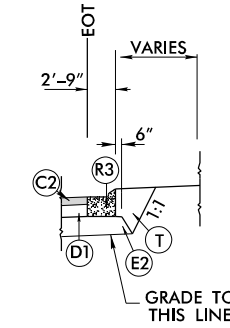

MEDIAN CURB DETAIL
 ALL 2'-9" CURBING LOCATIONS
 MIRROR FOR OPPOSITE DIRECTION
 USE CONCRETE CURB DETAIL IN
 CONJUNCTION WITH TYPICAL SECTIONS
 3, 9, 14, & 17
 SEE PLANS FOR LOCATIONS

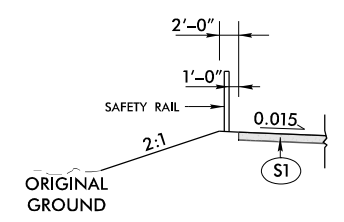

SAFETY RAIL DETAIL
 MIRROR FOR OPPOSITE DIRECTION
 USE SAFETY RAIL DETAIL IN
 CONJUNCTION WITH TYPICAL SECTIONS
 1, 2, 13, 14, 17, & 27
 SEE PLANS FOR LOCATIONS

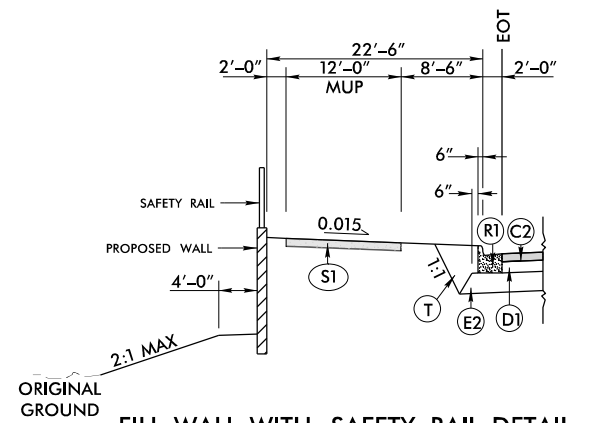

FILL WALL WITH SAFETY RAIL DETAIL
 ALL WALL LOCATIONS
 MIRROR FOR OPPOSITE DIRECTION
 USE FILL WALL WITH SAFETY RAIL DETAIL
 IN CONJUNCTION WITH TYPICAL
 SECTIONS NO. 2 & 13
 -L- STA. 34+50.00 TO STA. 37+70.31 LT
 -Y3- STA. 20+00.00 TO STA. 21+10.00 RT

HNTB HNTB NORTH CAROLINA, P.C.
 101 S. Tryon Street, Suite 3610
 Charlotte, North Carolina 28280
 NC License No: C-1554

PROJECT REFERENCE NO.	SHEET NO.
U-5768	2A-1
RW SHEET NO.	
ROADWAY DESIGN ENGINEER	PAVEMENT DESIGN ENGINEER
INCOMPLETE PLANS DO NOT USE FOR R/W ACQUISITION	
DOCUMENT NOT CONSIDERED FINAL UNLESS ALL SIGNATURES COMPLETED	

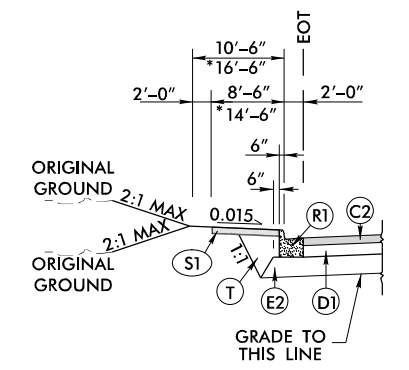

SIDEWALK AT BACK OF CURB DETAIL
 MIRROR FOR OPPOSITE DIRECTION
 USE SIDEWALK AT BACK OF CURB DETAIL IN CONJUNCTION
 WITH TYPICAL SECTIONS NO. 7 & 13
 -Y2- STA. 10+52.28 TO STA. 12+56.98 RT
 -Y4- STA. 12+60.00 TO STA. 14+80.00 LT & RT

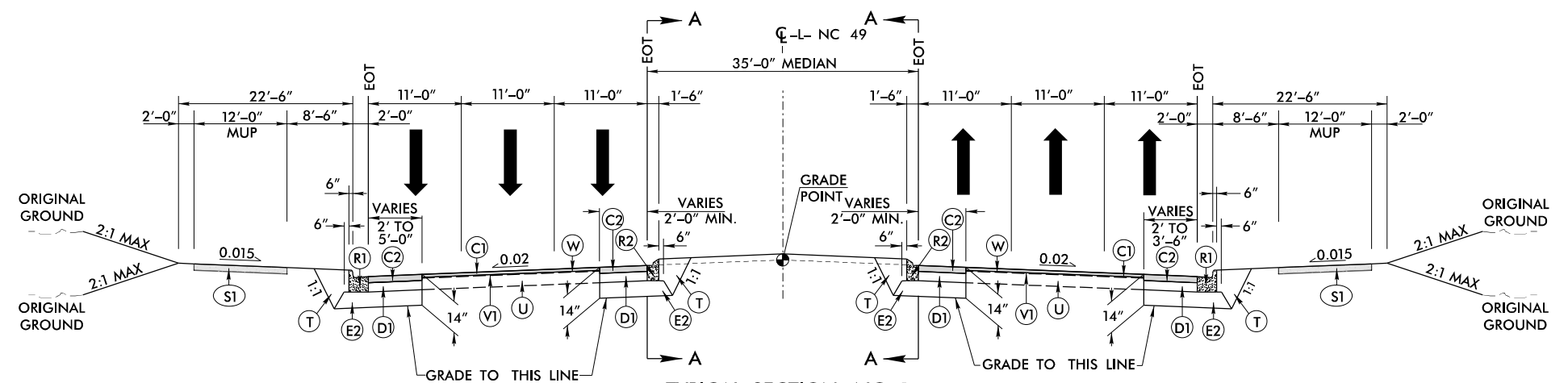

TYPICAL SECTION NO. 1
 -L- NC 49
 USE TYPICAL SECTION NO. 1
 -L- STA. 12+75.00 TO STA. 36+25.00
 -L- STA. 54+45.00 TO STA. 60+00.00

5/14/99

70-AUG-2001 09:55
 C:\p05\p05\11\c3\U5768.RDY_TYP.dgn

AWAITING FINAL PAVEMENT SCHEDULE	
C1	PROP. APPROX. 1.5" ACSC, TYPE S9.5C
C2	PROP. APPROX. 3" ACSC, TYPE S9.5C
C3	PROP. VAR. DEPTH ACSC, TYPE S9.5C
D1	PROP. APPROX. 4" ACIC, TYPE I19.0C
D2	PROP. VAR. DEPTH ACIC, TYPE I19.0C
E1	PROP. APPROX. 4" ACBC, TYPE B25.0C
E2	PROP. APPROX. 7" ACBC, TYPE B25.0C
E3	PROP. VAR. DEPTH ACBC, TYPE B25.0C
J1	7" AGGREGATE BASE COURSE.
R1	2'-6" CONCRETE CURB AND GUTTER.
R2	1'-6" CONCRETE CURB AND GUTTER.
R3	2'-9" CONCRETE CURB AND GUTTER.
R4	5" MONOLITHIC CONCRETE ISLAND (KEYED IN).
S1	4" CONCRETE SIDEWALK.
T	EARTH MATERIAL.
U	EXISTING PAVEMENT.
V1	MILLING BITUMINOUS PAVEMENT 1.5".
V2	INCIDENTAL MILLING .
W	VARIABLE DEPTH ASPHALT PAVEMENT. (SEE DETAIL No. 1 SHOWING METHOD OF WEDGING)

NOTE: PAVEMENT EDGE SLOPES ARE 1:1 UNLESS SHOWN OTHERWISE.

PROJECT REFERENCE NO. U-5768	SHEET NO. 2A-2
RW SHEET NO.	
ROADWAY DESIGN ENGINEER	PAVEMENT DESIGN ENGINEER
INCOMPLETE PLANS DO NOT USE FOR R/W ACQUISITION	
DOCUMENT NOT CONSIDERED FINAL UNLESS ALL SIGNATURES COMPLETED	

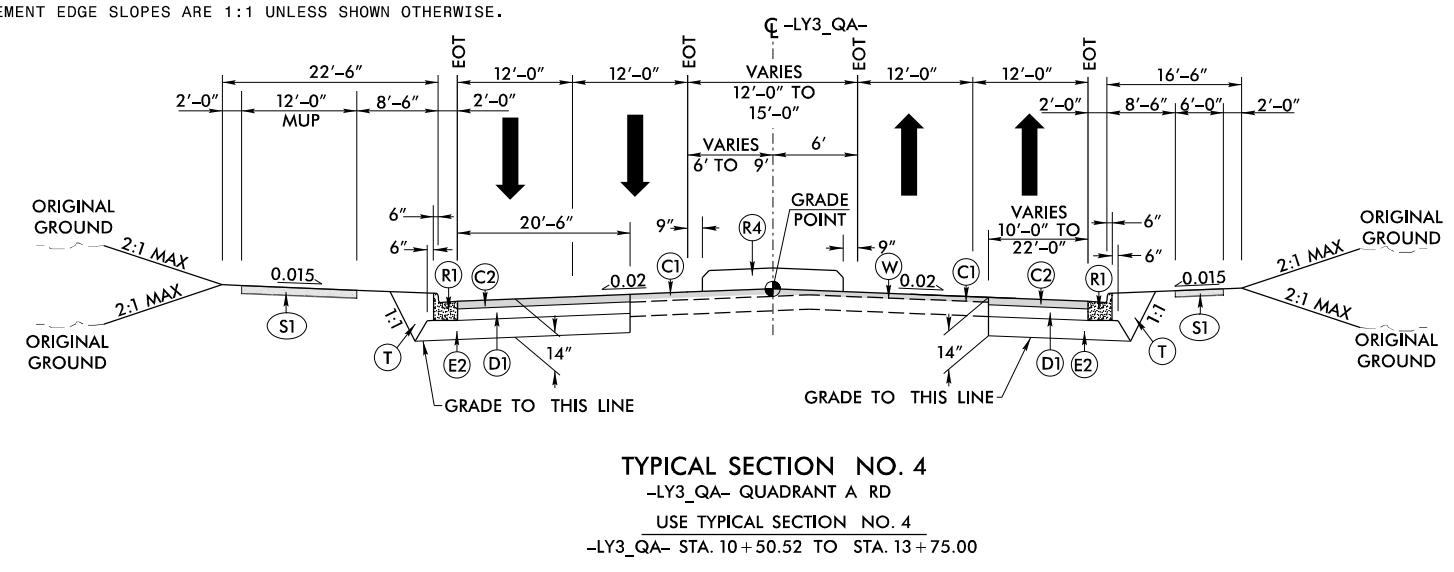
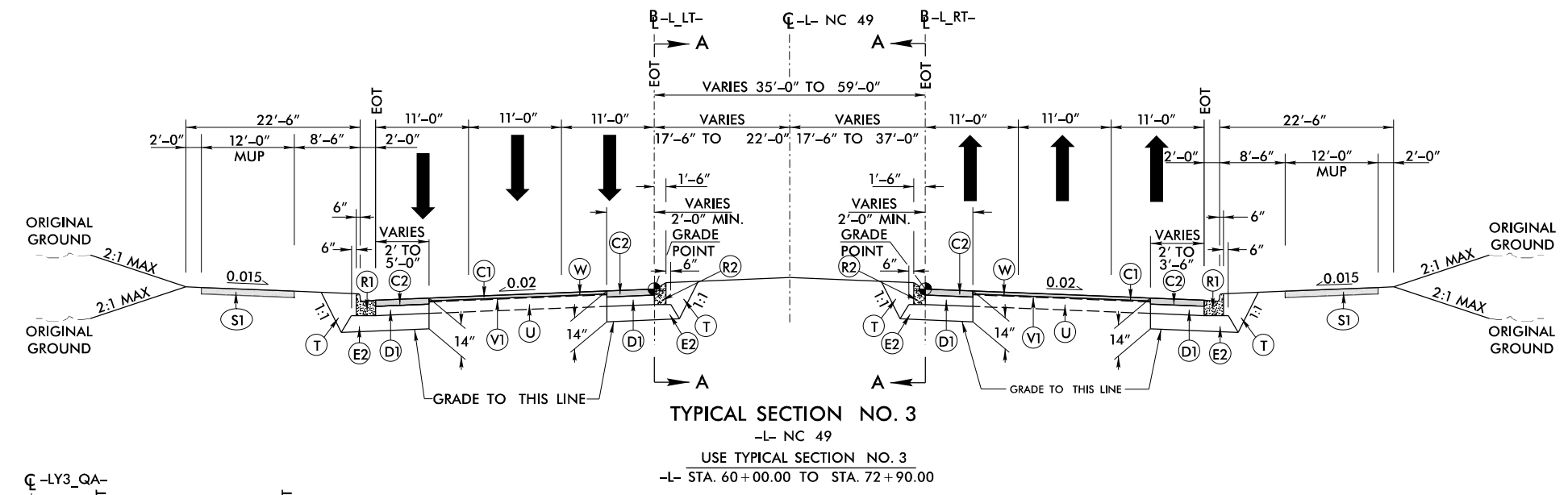
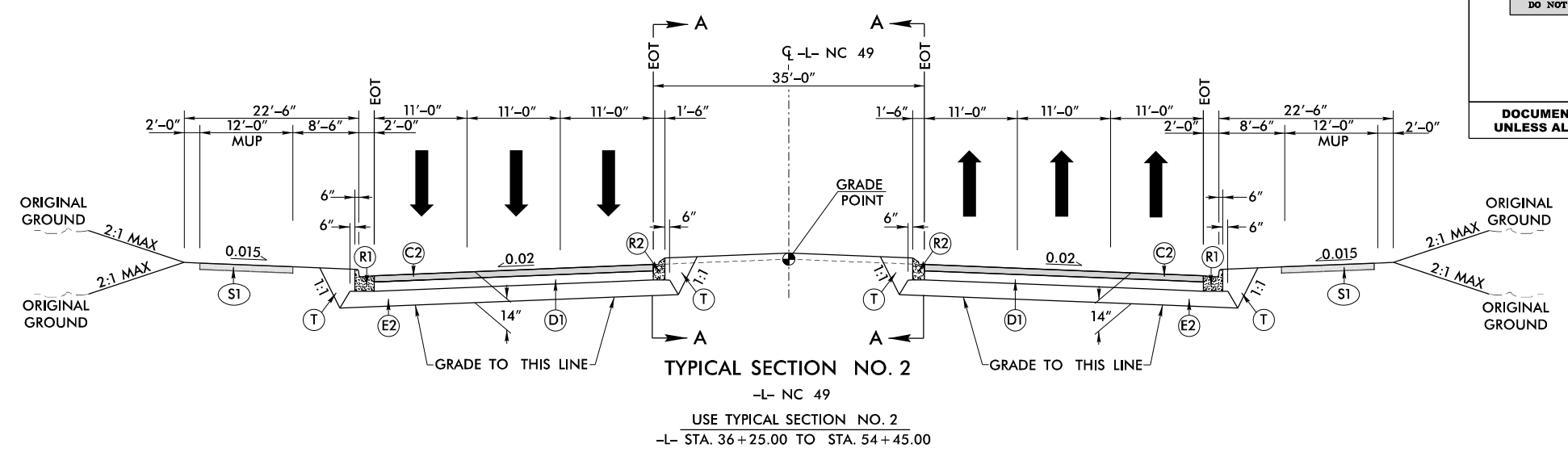

5/14/99

70-AUG-2001 09:55
 C:\p05\11\105768.RDY_TYP.dgn
 11/18/01

AWAITING FINAL PAVEMENT SCHEDULE	
C1	PROP. APPROX. 1.5" ACSC, TYPE S9.5C
C2	PROP. APPROX. 3" ACSC, TYPE S9.5C
C3	PROP. VAR. DEPTH ACSC, TYPE S9.5C
D1	PROP. APPROX. 4" ACIC, TYPE I19.0C
D2	PROP. VAR. DEPTH ACIC, TYPE I19.0C
E1	PROP. APPROX. 4" ACBC, TYPE B25.0C
E2	PROP. APPROX. 7" ACBC, TYPE B25.0C
E3	PROP. VAR. DEPTH ACBC, TYPE B25.0C
J1	7" AGGREGATE BASE COURSE.
R1	2'-6" CONCRETE CURB AND GUTTER.
R2	1'-6" CONCRETE CURB AND GUTTER.
R3	2'-9" CONCRETE CURB AND GUTTER.
R4	5" MONOLITHIC CONCRETE ISLAND (KEYED IN).
S1	4" CONCRETE SIDEWALK.
T	EARTH MATERIAL.
U	EXISTING PAVEMENT.
V1	MILLING BITUMINOUS PAVEMENT 1.5".
V2	INCIDENTAL MILLING .
W	VARIABLE DEPTH ASPHALT PAVEMENT. (SEE DETAIL No. 1 SHOWING METHOD OF WEDGING)

NOTE: PAVEMENT EDGE SLOPES ARE 1:1 UNLESS SHOWN OTHERWISE.

PROJECT REFERENCE NO. U-5768	SHEET NO. 2A-3
RW SHEET NO.	
ROADWAY DESIGN ENGINEER	PAVEMENT DESIGN ENGINEER
INCOMPLETE PLANS DO NOT USE FOR R/W ACQUISITION	
DOCUMENT NOT CONSIDERED FINAL UNLESS ALL SIGNATURES COMPLETED	

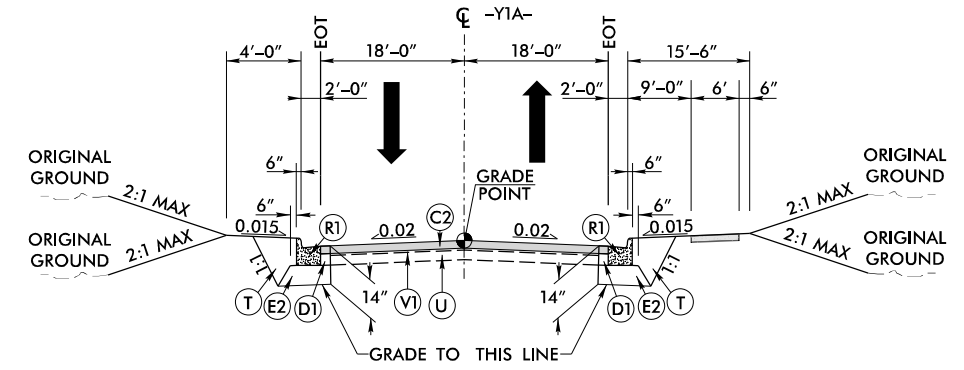
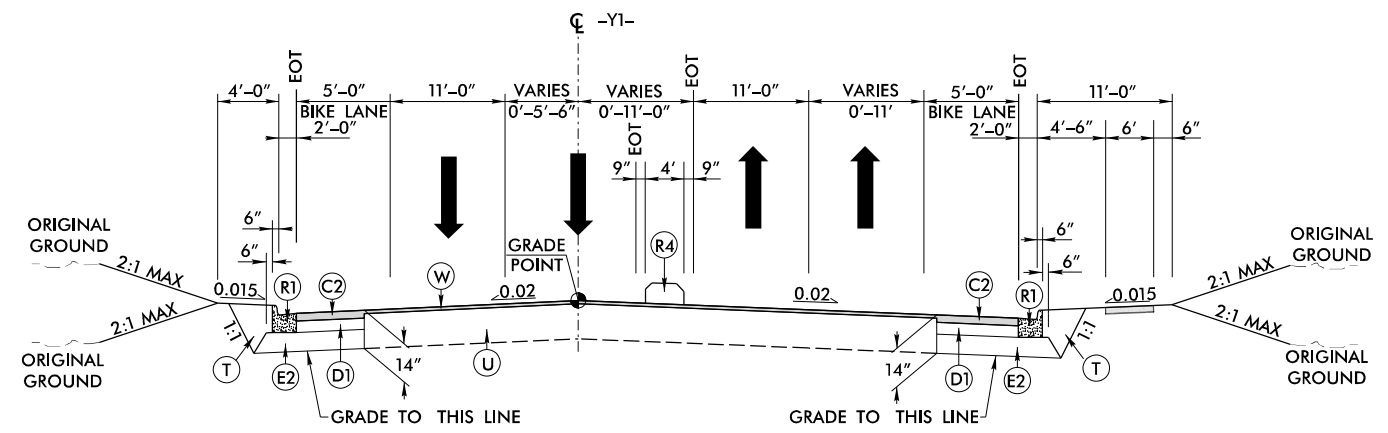
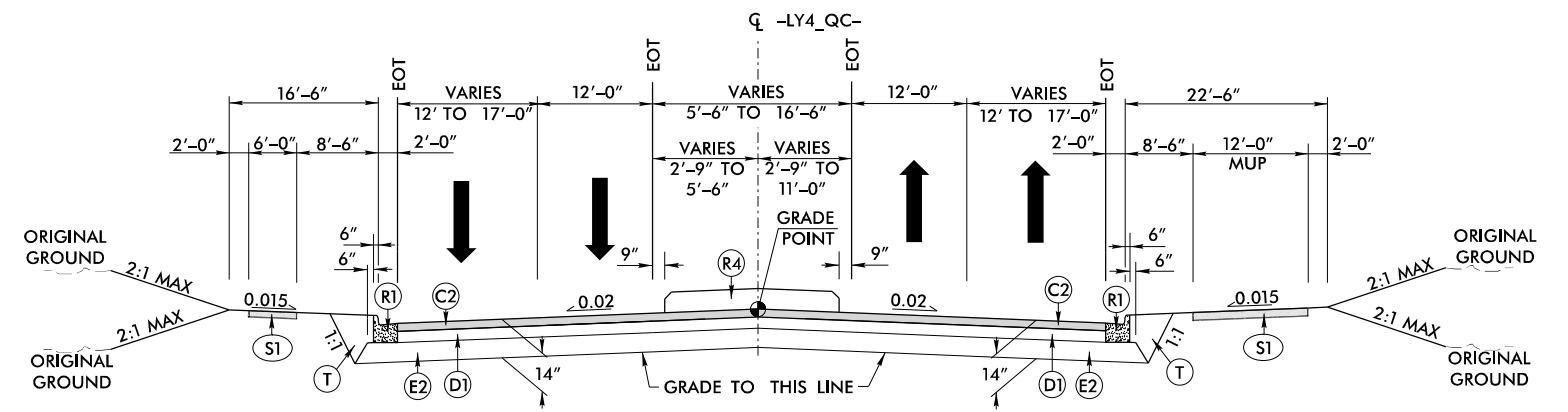
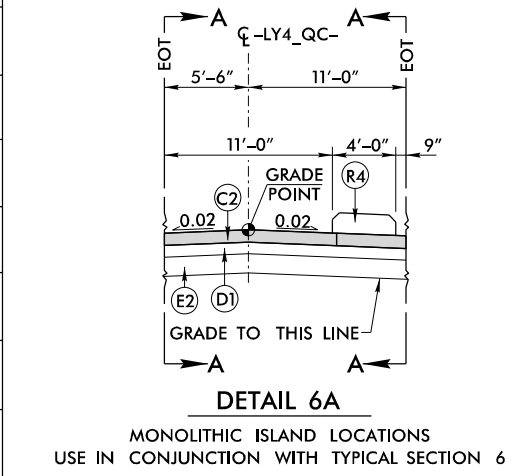
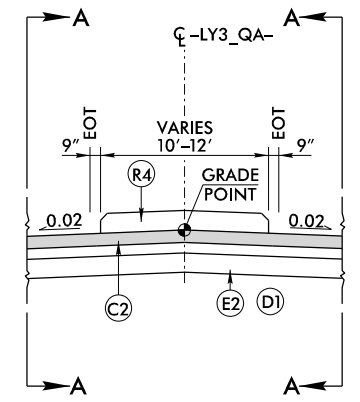
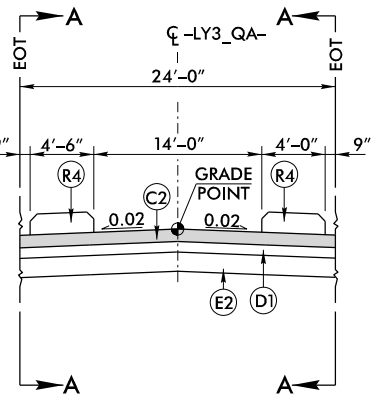
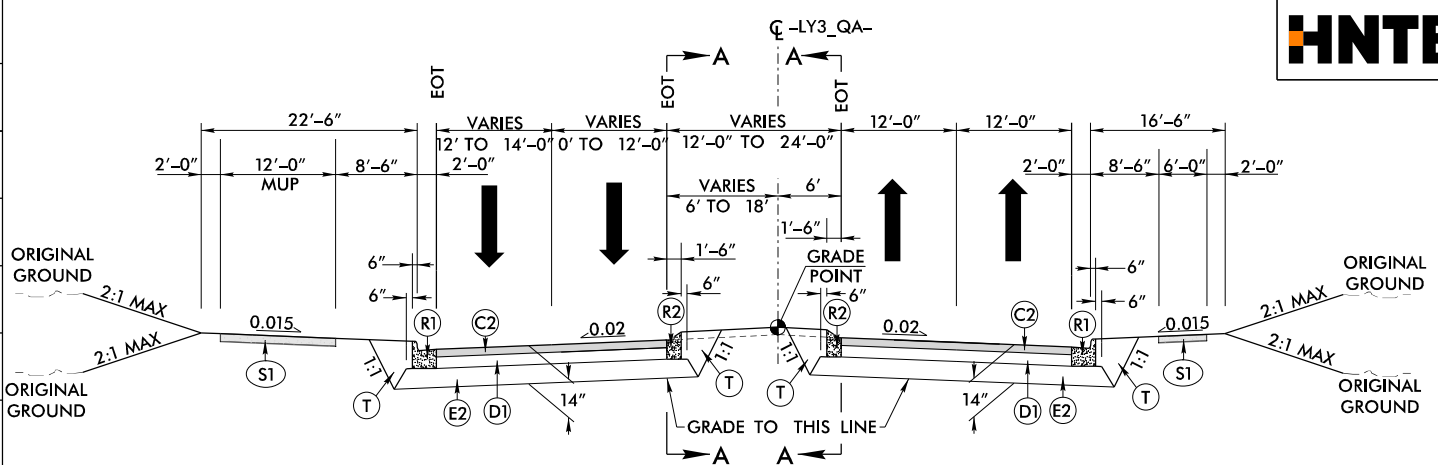

5/14/99

AWAITING FINAL PAVEMENT SCHEDULE	
C1	PROP. APPROX. 1.5" ACSC, TYPE S9.5C
C2	PROP. APPROX. 3" ACSC, TYPE S9.5C
C3	PROP. VAR. DEPTH ACSC, TYPE S9.5C
D1	PROP. APPROX. 4" ACIC, TYPE I19.0C
D2	PROP. VAR. DEPTH ACIC, TYPE I19.0C
E1	PROP. APPROX. 4" ACBC, TYPE B25.0C
E2	PROP. APPROX. 7" ACBC, TYPE B25.0C
E3	PROP. VAR. DEPTH ACBC, TYPE B25.0C
J1	7" AGGREGATE BASE COURSE.
R1	2'-6" CONCRETE CURB AND GUTTER.
R2	1'-6" CONCRETE CURB AND GUTTER.
R3	2'-9" CONCRETE CURB AND GUTTER.
R4	5" MONOLITHIC CONCRETE ISLAND (KEYED IN).
S1	4" CONCRETE SIDEWALK.
T	EARTH MATERIAL.
U	EXISTING PAVEMENT.
V1	MILLING BITUMINOUS PAVEMENT 1.5".
V2	INCIDENTAL MILLING .
W	VARIABLE DEPTH ASPHALT PAVEMENT. (SEE DETAIL No. 1 SHOWING METHOD OF WEDGING)

NOTE: PAVEMENT EDGE SLOPES ARE 1:1 UNLESS SHOWN OTHERWISE.

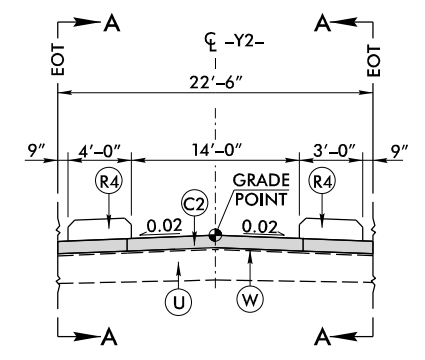

DETAIL 9A
MONOLITHIC ISLAND LOCATIONS
USE IN CONJUNCTION WITH TYPICAL SECTION 9

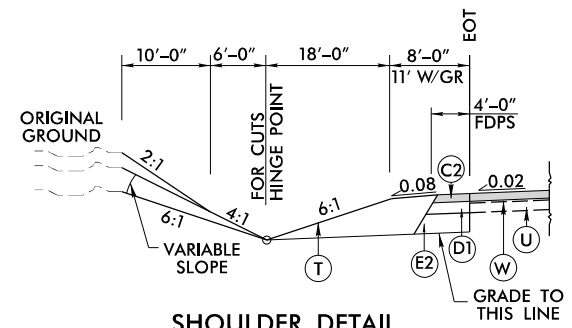

SHOULDER DETAIL
USE SHOULDER DETAIL IN CONJUNCTION WITH TYPICAL SECTION NO. 9
-Y2- STA. 17+28.49 TO STA. 22+00.00 LT

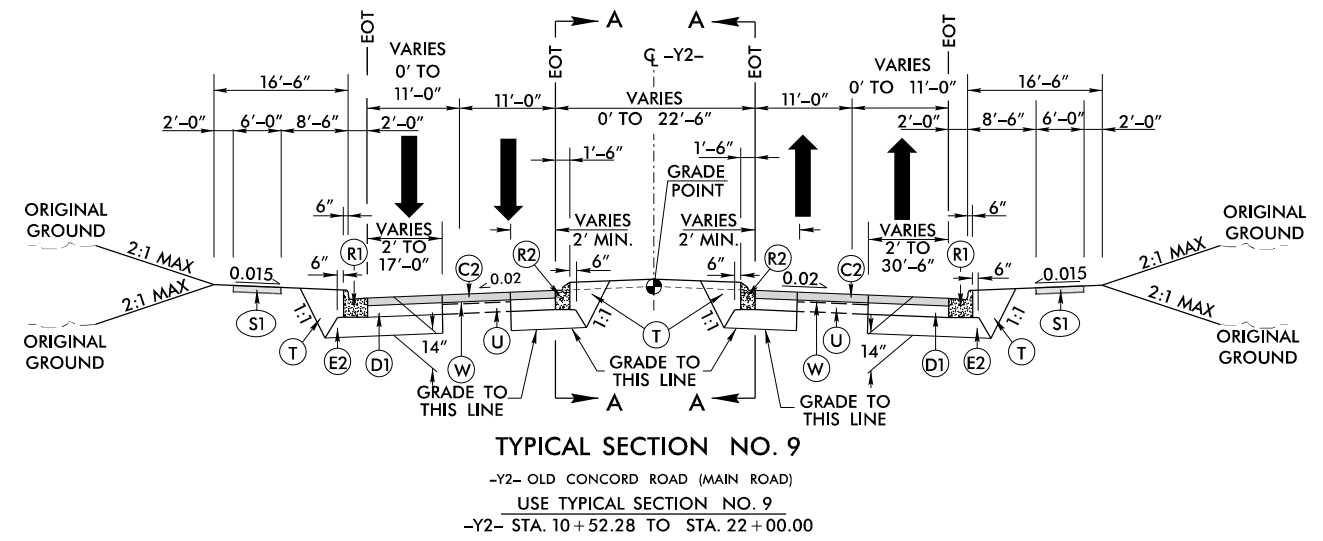

TYPICAL SECTION NO. 9
-Y2- OLD CONCORD ROAD (MAIN ROAD)
USE TYPICAL SECTION NO. 9
-Y2- STA. 10+52.28 TO STA. 22+00.00

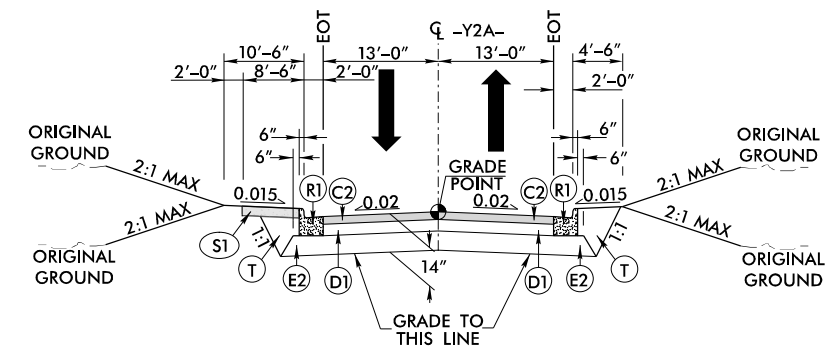

TYPICAL SECTION NO. 10
-Y2A- OLD CONCORD RD (SIDE STREET)
USE TYPICAL SECTION NO. 10
-Y2A- STA. 10+31.95 TO STA. 10+80.18
-Y2A- STA. 19+95.19 TO STA. 24+31.33

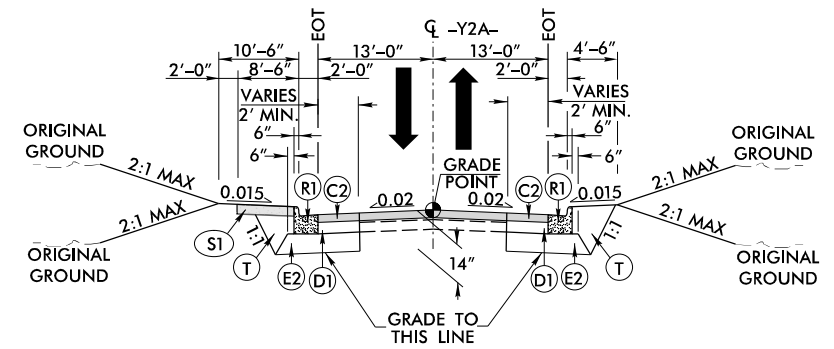

TYPICAL SECTION NO. 11
-Y2A- OLD CONCORD RD (SIDE STREET)
USE TYPICAL SECTION NO. 11
-Y2A- STA. 10+80.18 TO STA. 19+95.19

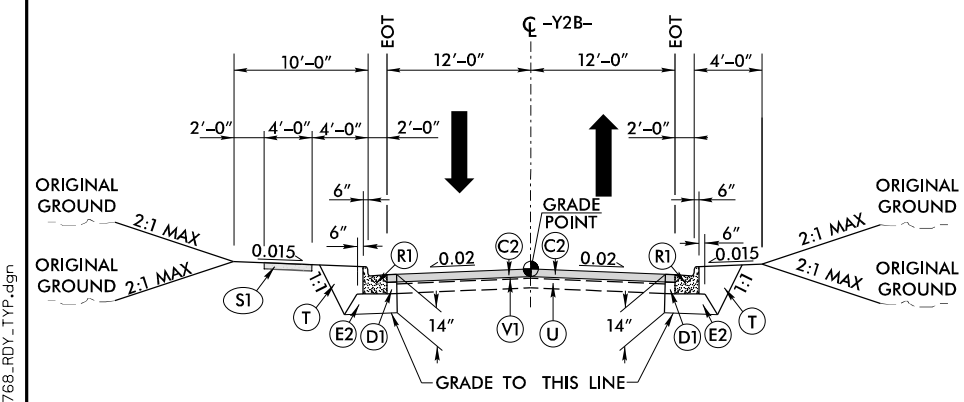

TYPICAL SECTION NO. 12
-Y2B- MARGIE ANN DR
USE TYPICAL SECTION NO. 12
-Y2B- STA. 10+70.00 TO STA. 11+72.25

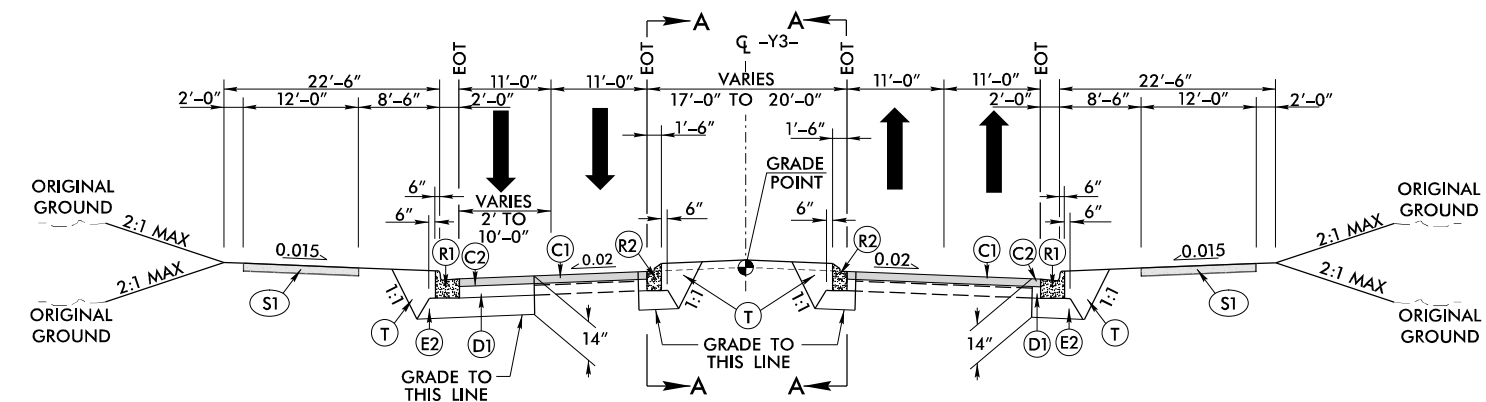

TYPICAL SECTION NO. 13
-Y3- EAST MALLARD CREEK CHURCH RD
USE TYPICAL SECTION NO. 13
-Y3- STA. 19+10.00 TO STA. 25+09.23

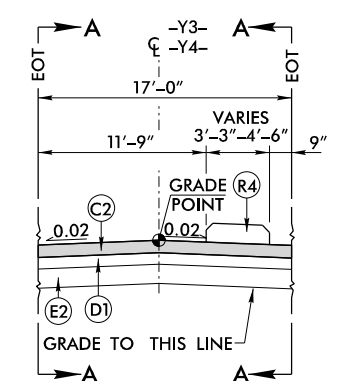

DETAIL 13A
MONOLITHIC ISLAND LOCATIONS
USE IN CONJUNCTION WITH TYPICAL SECTION 13 & 14
MIRROR FOR OPPOSITE DIRECTION

HNTB HNTB NORTH CAROLINA, P.C.
101 S. Tryon Street, Suite 3610
Charlotte, North Carolina 28280
NC License No: C-1554

PROJECT REFERENCE NO. U-5768	SHEET NO. 2A-4
RW SHEET NO.	
ROADWAY DESIGN ENGINEER	PAVEMENT DESIGN ENGINEER
INCOMPLETE PLANS DO NOT USE FOR R/W ACQUISITION	
DOCUMENT NOT CONSIDERED FINAL UNLESS ALL SIGNATURES COMPLETED	

70-AUG-2019 09:56 C:\p05\19556\U5768.RDY_TYP.dgn

5/14/99

AWAITING FINAL PAVEMENT SCHEDULE	
C1	PROP. APPROX. 1.5" ACSC, TYPE S9.5C
C2	PROP. APPROX. 3" ACSC, TYPE S9.5C
C3	PROP. VAR. DEPTH ACSC, TYPE S9.5C
D1	PROP. APPROX. 4" ACIC, TYPE I19.0C
D2	PROP. VAR. DEPTH ACIC, TYPE I19.0C
E1	PROP. APPROX. 4" ACBC, TYPE B25.0C
E2	PROP. APPROX. 7" ACBC, TYPE B25.0C
E3	PROP. VAR. DEPTH ACBC, TYPE B25.0C
J1	7" AGGREGATE BASE COURSE.
R1	2'-6" CONCRETE CURB AND GUTTER.
R2	1'-6" CONCRETE CURB AND GUTTER.
R3	2'-9" CONCRETE CURB AND GUTTER.
R4	5" MONOLITHIC CONCRETE ISLAND (KEYED IN).
S1	4" CONCRETE SIDEWALK.
T	EARTH MATERIAL.
U	EXISTING PAVEMENT.
V1	MILLING BITUMINOUS PAVEMENT 1.5".
V2	INCIDENTAL MILLING .
W	VARIABLE DEPTH ASPHALT PAVEMENT. (SEE DETAIL No. 1 SHOWING METHOD OF WEDGING)

NOTE: PAVEMENT EDGE SLOPES ARE 1:1 UNLESS SHOWN OTHERWISE.

HNTB HNTB NORTH CAROLINA, P.C.
101 S. Tryon Street, Suite 3610
Charlotte, North Carolina 28280
NC License No: C-1554

PROJECT REFERENCE NO. U-5768	SHEET NO. 2A-5
RW SHEET NO.	
ROADWAY DESIGN ENGINEER	PAVEMENT DESIGN ENGINEER
INCOMPLETE PLANS DO NOT USE FOR R/W ACQUISITION	
DOCUMENT NOT CONSIDERED FINAL UNLESS ALL SIGNATURES COMPLETED	

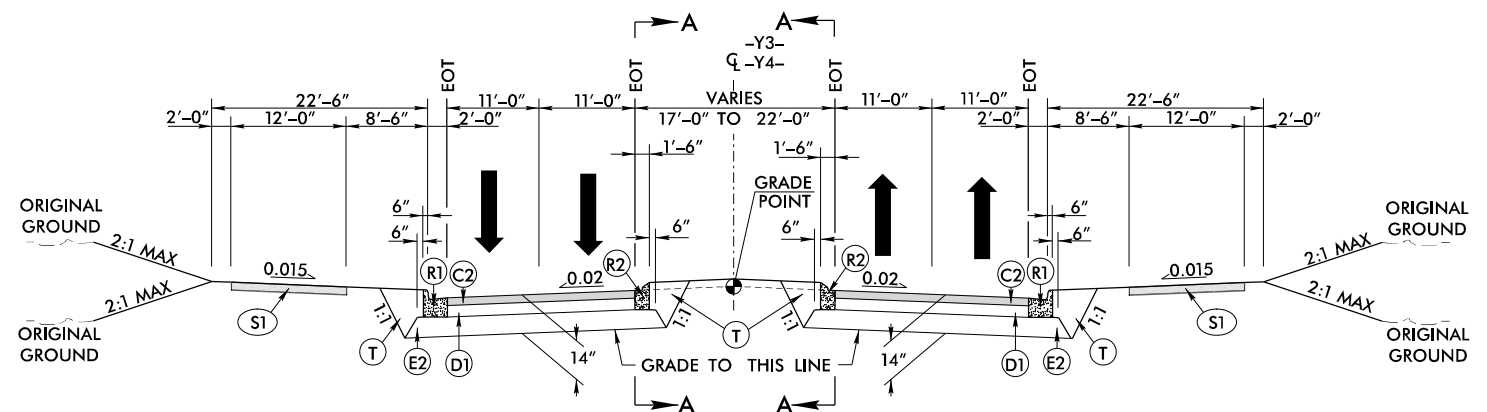

TYPICAL SECTION NO. 14
-Y3- EAST MALLARD CREEK CHURCH RD
-Y4- BACK CREEK CHURCH RD (NEW LOCATION)
USE TYPICAL SECTION NO. 14
-Y3- STA. 25+09.23 TO STA. 30+80.09
-Y4- STA. 10+50.51 TO STA. 13+76.38
-Y4- STA. 14+20.67 TO STA. 40+31 +/- (BEGIN BRIDGE)
-Y4- STA. 43+32 +/- (END BRIDGE) TO STA. 63+63.51

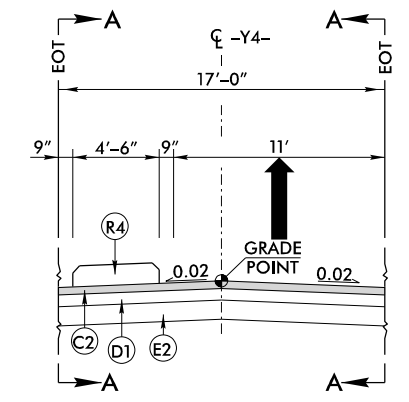

DETAIL 14A
MONOLITHIC ISLAND LOCATIONS
USE IN CONJUNCTION WITH TYPICAL SECTION 14
(SEE PLANS FOR LOCATIONS)

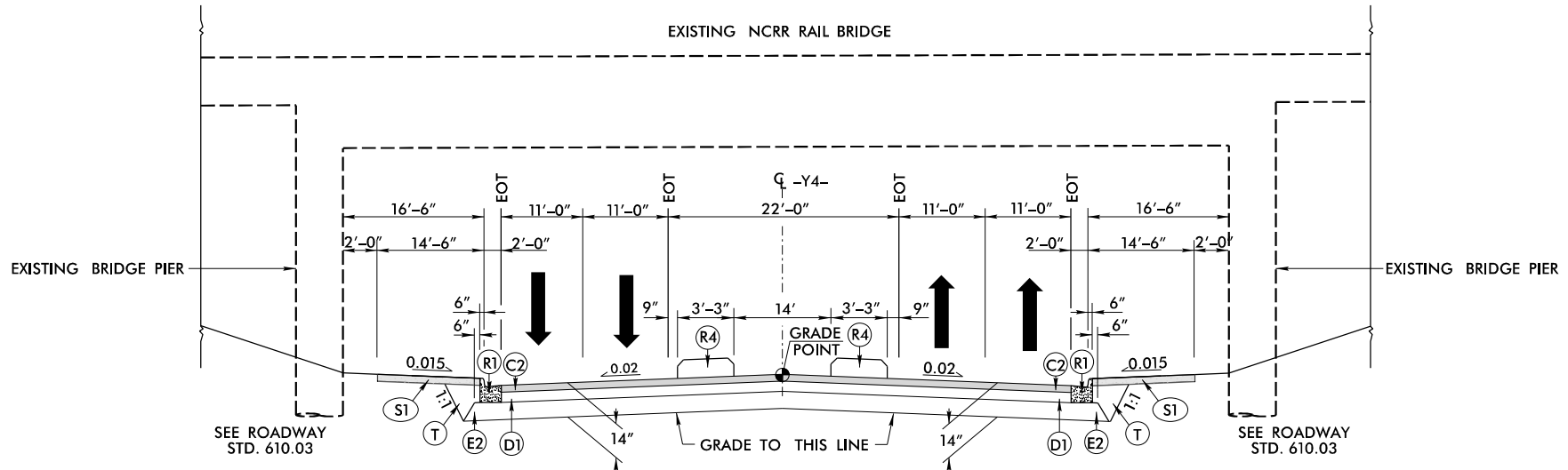

TYPICAL SECTION NO. 15
-Y4- BACK CREEK CHURCH RD (NEW LOCATION) BRIDGE UNDERPASS
USE TYPICAL SECTION NO. 15
-Y4- STA. 13+76.38 TO STA. 14+20.67

70-AUG-20(19)55
C:\p05\p1\c3\U5768.RDY_TYP.dgn

5/14/99

20-AUG-2009 09:55
 C:\p05\p05\p05\U5768.RDY_TYP.dgn
 HNTB

AWAITING FINAL PAVEMENT SCHEDULE	
C1	PROP. APPROX. 1.5" ACSC, TYPE S9.5C
C2	PROP. APPROX. 3" ACSC, TYPE S9.5C
C3	PROP. VAR. DEPTH ACSC, TYPE S9.5C
D1	PROP. APPROX. 4" ACIC, TYPE I19.0C
D2	PROP. VAR. DEPTH ACIC, TYPE I19.0C
E1	PROP. APPROX. 4" ACBC, TYPE B25.0C
E2	PROP. APPROX. 7" ACBC, TYPE B25.0C
E3	PROP. VAR. DEPTH ACBC, TYPE B25.0C
J1	7" AGGREGATE BASE COURSE.
R1	2'-6" CONCRETE CURB AND GUTTER.
R2	1'-6" CONCRETE CURB AND GUTTER.
R3	2'-9" CONCRETE CURB AND GUTTER.
R4	5" MONOLITHIC CONCRETE ISLAND (KEYED IN).
S1	4" CONCRETE SIDEWALK.
T	EARTH MATERIAL.
U	EXISTING PAVEMENT.
V1	MILLING BITUMINOUS PAVEMENT 1.5".
V2	INCIDENTAL MILLING .
W	VARIABLE DEPTH ASPHALT PAVEMENT. (SEE DETAIL No. 1 SHOWING METHOD OF WEDGING)

NOTE: PAVEMENT EDGE SLOPES ARE 1:1 UNLESS SHOWN OTHERWISE.

PROJECT REFERENCE NO. U-5768	SHEET NO. 2A-7
RW SHEET NO.	
ROADWAY DESIGN ENGINEER	PAVEMENT DESIGN ENGINEER
INCOMPLETE PLANS DO NOT USE FOR R/W ACQUISITION	
DOCUMENT NOT CONSIDERED FINAL UNLESS ALL SIGNATURES COMPLETED	

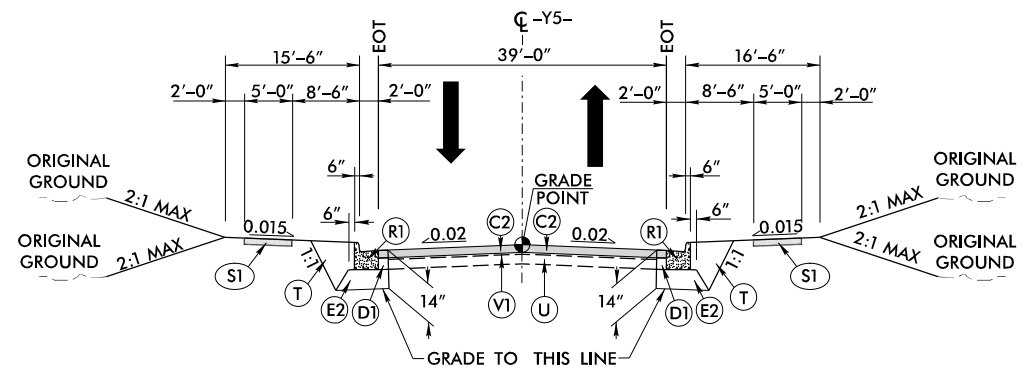

TYPICAL SECTION NO. 19
 -Y5- SAMS LN
 USE TYPICAL SECTION NO. 19
 -Y5- STA. 11+20.00 TO STA. 12+24.20

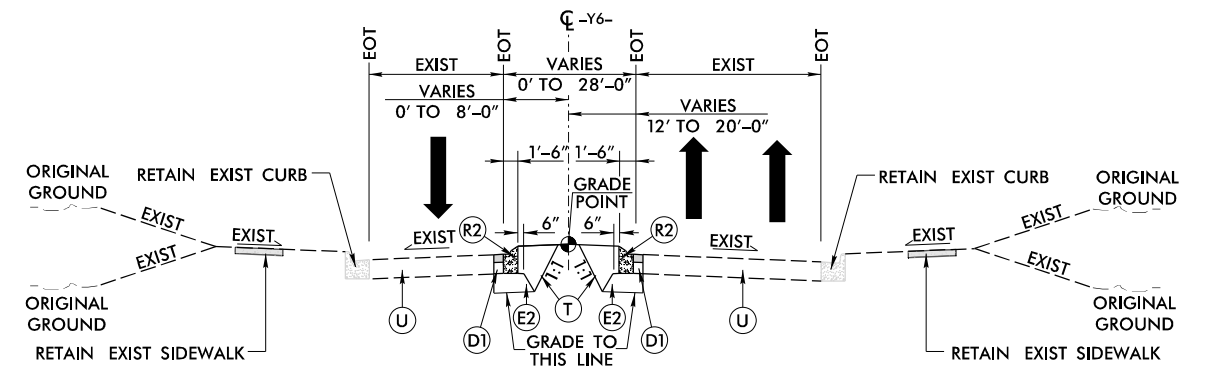

TYPICAL SECTION NO. 20
 -Y6- PAVILION BLVD
 USE TYPICAL SECTION NO. 20
 -Y6- STA. 15+20.00 TO STA. 18+00.00

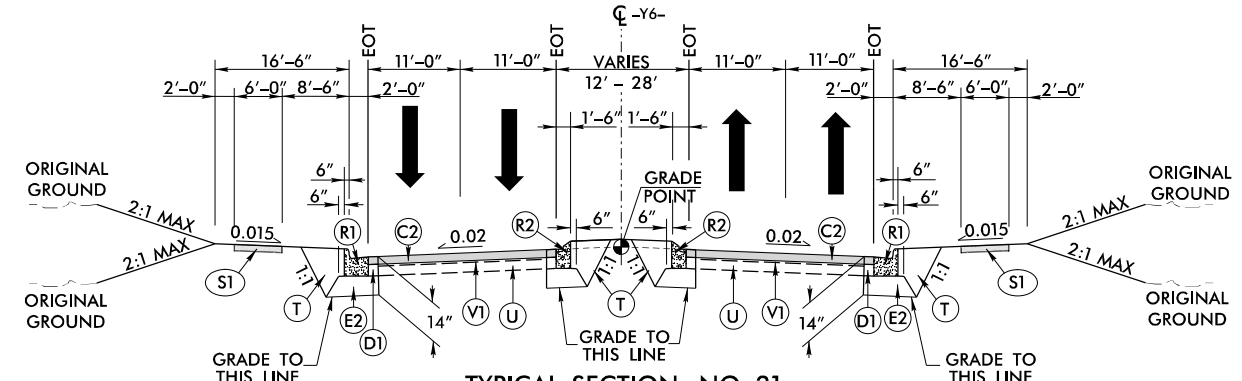

TYPICAL SECTION NO. 21
 -Y6- PAVILION BLVD
 USE TYPICAL SECTION NO. 21
 -Y6- STA. 18+00.00 TO STA. 19+03.93

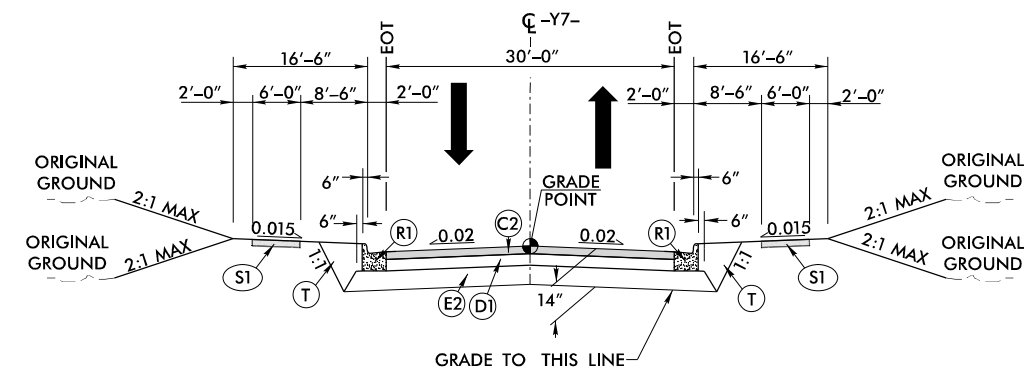

TYPICAL SECTION NO. 22
 -Y7- THOMAS COMBS DR
 USE TYPICAL SECTION NO. 22
 -Y7- STA. 11+15.00 TO STA. 11+98.93

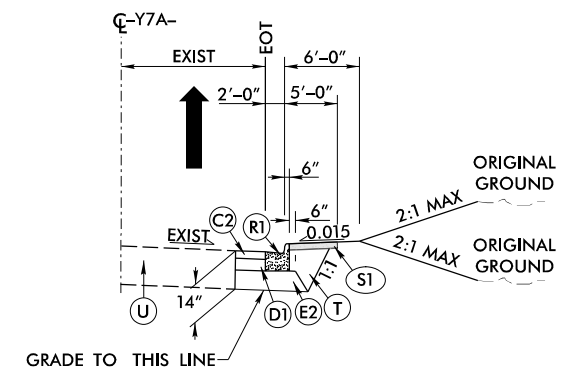

TYPICAL SECTION NO. 23
 -Y7A- DABNEY DR
 USE TYPICAL SECTION NO. 23
 -Y7A- STA. 10+18.88 TO STA. 10+66.00

5/14/99

70-AUG-20(1)955
 3
 08
 05
 17
 03
 U5768.RDY_TYP.dgn

AWAITING FINAL PAVEMENT SCHEDULE	
C1	PROP. APPROX. 1.5" ACSC, TYPE S9.5C
C2	PROP. APPROX. 3" ACSC, TYPE S9.5C
C3	PROP. VAR. DEPTH ACSC, TYPE S9.5C
D1	PROP. APPROX. 4" ACIC, TYPE I19.0C
D2	PROP. VAR. DEPTH ACIC, TYPE I19.0C
E1	PROP. APPROX. 4" ACBC, TYPE B25.0C
E2	PROP. APPROX. 7" ACBC, TYPE B25.0C
E3	PROP. VAR. DEPTH ACBC, TYPE B25.0C
J1	7" AGGREGATE BASE COURSE.
R1	2'-6" CONCRETE CURB AND GUTTER.
R2	1'-6" CONCRETE CURB AND GUTTER.
R3	2'-9" CONCRETE CURB AND GUTTER.
R4	5" MONOLITHIC CONCRETE ISLAND (KEYED IN).
S1	4" CONCRETE SIDEWALK.
T	EARTH MATERIAL.
U	EXISTING PAVEMENT.
V1	MILLING BITUMINOUS PAVEMENT 1.5".
V2	INCIDENTAL MILLING .
W	VARIABLE DEPTH ASPHALT PAVEMENT. (SEE DETAIL No. 1 SHOWING METHOD OF WEDGING)

NOTE: PAVEMENT EDGE SLOPES ARE 1:1 UNLESS SHOWN OTHERWISE.

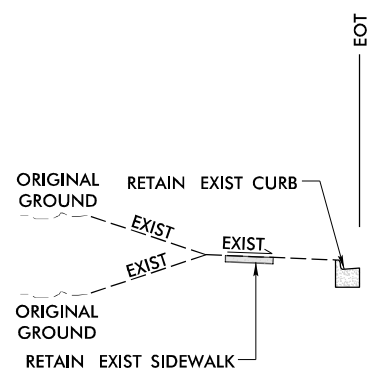

DETAIL 24A
 RETAIN EXISTING CURB LOCATIONS
 USE IN CONJUNCTION WITH TYPICAL SECTION 24
 (SEE PLANS FOR LOCATIONS)

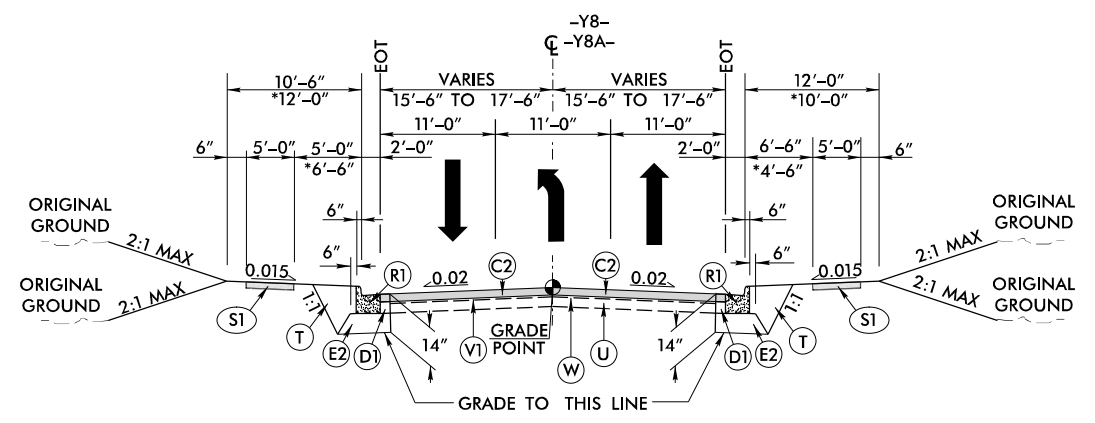

TYPICAL SECTION NO. 24
 -Y8- HANBERRY BLVD
 -Y8A- HANBERRY BLVD
 USE TYPICAL SECTION NO. 24
 -Y8- STA. 10+37.00 TO STA. 12+95.39
 -Y8A- STA. 10+30.50 TO STA. 13+20.00

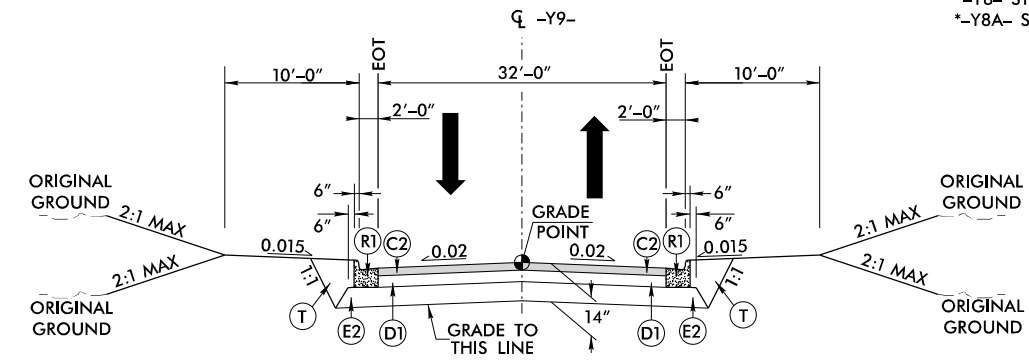

TYPICAL SECTION NO. 25
 -Y9- HANBERRY BLVD
 USE TYPICAL SECTION NO. 25
 -Y9- STA. 10+30.50 TO STA. 11+00.00

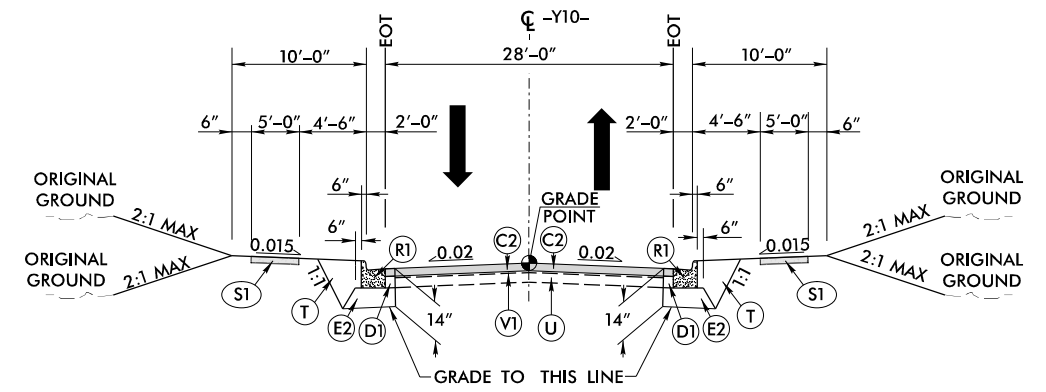

TYPICAL SECTION NO. 26
 -Y10- PARSIFAL LN
 USE TYPICAL SECTION NO. 26
 -Y10- STA. 10+30.50 TO STA. 14+00.00

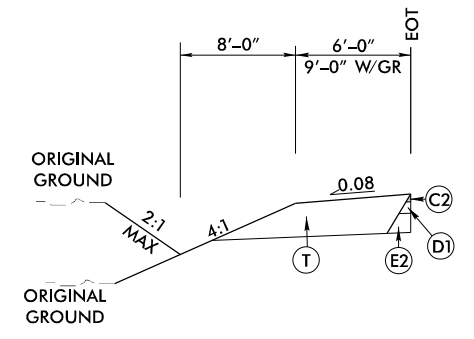

DETAIL 27A
 SHOULDER LOCATIONS
 USE IN CONJUNCTION WITH TYPICAL SECTION 27
 (SEE PLANS FOR LOCATIONS)
 NOTE: MIRROR FOR RT SIDE

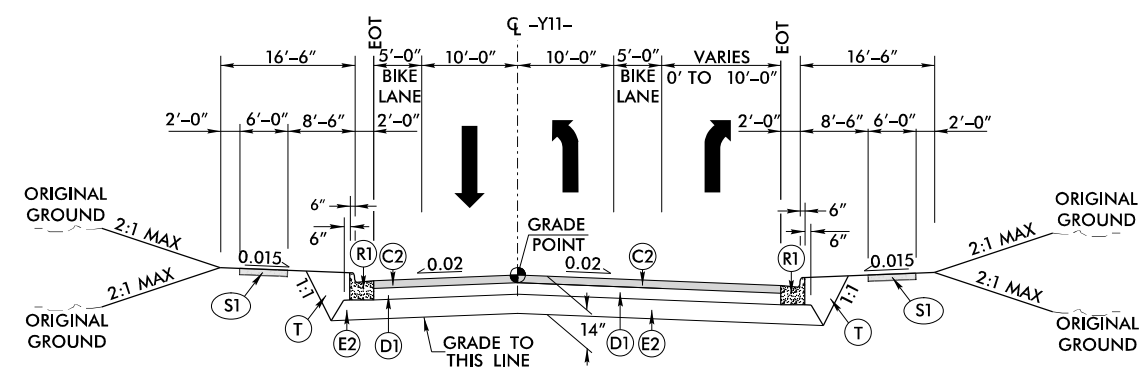

TYPICAL SECTION NO. 27
 -Y11- BACK CREEK CHURCH RD (REALIGNMENT)
 USE TYPICAL SECTION NO. 27
 -Y11- STA. 15+50.00 TO STA. 24+48.39

HNTB HNTB NORTH CAROLINA, P.C.
 101 S. Tryon Street, Suite 3610
 Charlotte, North Carolina 28280
 NC License No: C-1554

PROJECT REFERENCE NO. U-5768	SHEET NO. 2A-8
RW SHEET NO.	
ROADWAY DESIGN ENGINEER	PAVEMENT DESIGN ENGINEER
INCOMPLETE PLANS DO NOT USE FOR R/W ACQUISITION	
DOCUMENT NOT CONSIDERED FINAL UNLESS ALL SIGNATURES COMPLETED	

5/14/99

70-AUG-20(19)55
 3/20/05 (P-C) U5768.RDY_TYP.dgn
 HNTB

AWAITING FINAL PAVEMENT SCHEDULE	
C1	PROP. APPROX. 1.5" ACSC, TYPE S9.5C
C2	PROP. APPROX. 3" ACSC, TYPE S9.5C
C3	PROP. VAR. DEPTH ACSC, TYPE S9.5C
D1	PROP. APPROX. 4" ACIC, TYPE I19.0C
D2	PROP. VAR. DEPTH ACIC, TYPE I19.0C
E1	PROP. APPROX. 4" ACBC, TYPE B25.0C
E2	PROP. APPROX. 7" ACBC, TYPE B25.0C
E3	PROP. VAR. DEPTH ACBC, TYPE B25.0C
J1	7" AGGREGATE BASE COURSE.
R1	2'-6" CONCRETE CURB AND GUTTER.
R2	1'-6" CONCRETE CURB AND GUTTER.
R3	2'-9" CONCRETE CURB AND GUTTER.
R4	5" MONOLITHIC CONCRETE ISLAND (KEYED IN).
S1	4" CONCRETE SIDEWALK.
T	EARTH MATERIAL.
U	EXISTING PAVEMENT.
V1	MILLING BITUMINOUS PAVEMENT 1.5".
V2	INCIDENTAL MILLING .
W	VARIABLE DEPTH ASPHALT PAVEMENT. (SEE DETAIL No. 1 SHOWING METHOD OF WEDGING)

NOTE: PAVEMENT EDGE SLOPES ARE 1:1 UNLESS SHOWN OTHERWISE.

PROJECT REFERENCE NO. U-5768	SHEET NO. 2A-9
RW SHEET NO.	
ROADWAY DESIGN ENGINEER	PAVEMENT DESIGN ENGINEER
INCOMPLETE PLANS DO NOT USE FOR R/W ACQUISITION	
DOCUMENT NOT CONSIDERED FINAL UNLESS ALL SIGNATURES COMPLETED	

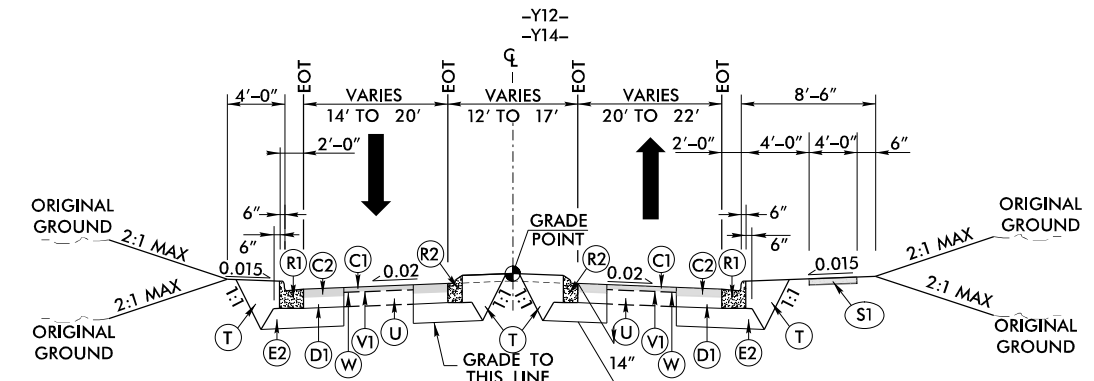

TYPICAL SECTION NO. 28
 -Y12- ROSEMALLOW RD
 -Y14- WYNDHAM POINT DR
 USE TYPICAL SECTION NO. 28
 -Y12- STA. 10+70.00 TO STA. 11+55.16
 -Y14- STA. 10+16.50 TO STA. 11+25.00

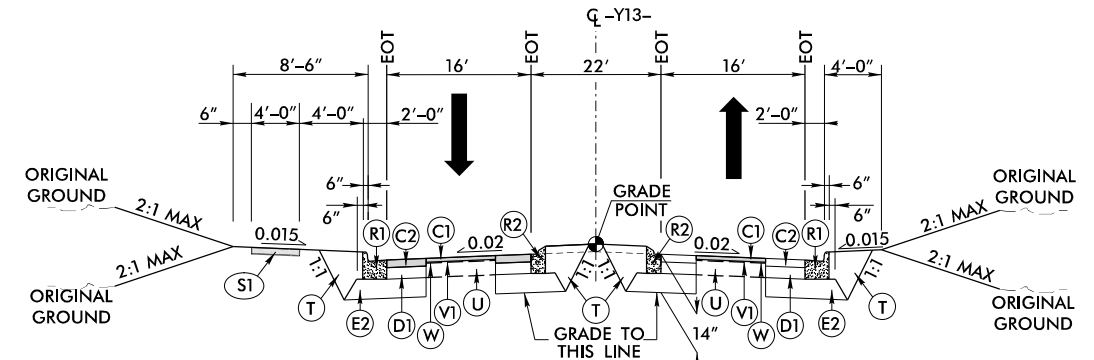

TYPICAL SECTION NO. 29
 -Y13- COREOPSIS RD
 USE TYPICAL SECTION NO. 29
 -Y13- STA. 11+50.00 TO STA. 11+99.66

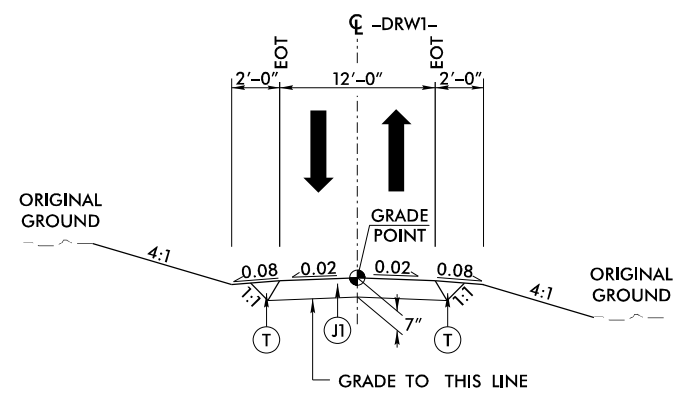

TYPICAL SECTION NO. 30
 -DRW1-
 USE TYPICAL SECTION NO. 30
 -DRW1- STA. 10+00.00 TO STA. 14+26.02

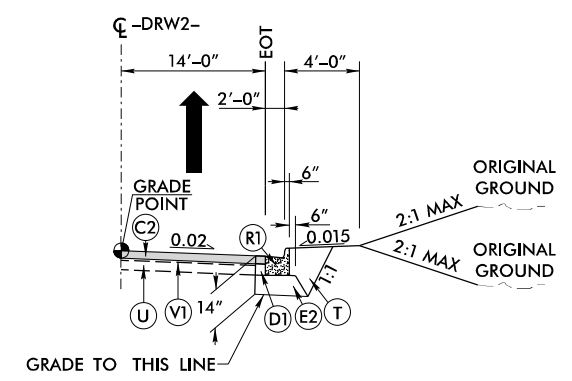

TYPICAL SECTION NO. 31
 -DRW2-
 USE TYPICAL SECTION NO. 31
 -DRW2- STA. 10+12.00 TO STA. 12+41.85

5/14/99

70-AUG-2001 09:55
 C:\p05\p1\c01\5768.RDY_TYP.dgn
 HNTB

AWAITING FINAL PAVEMENT SCHEDULE	
C1	PROP. APPROX. 1.5" ACSC, TYPE S9.5C
C2	PROP. APPROX. 3" ACSC, TYPE S9.5C
C3	PROP. VAR. DEPTH ACSC, TYPE S9.5C
D1	PROP. APPROX. 4" ACIC, TYPE I19.0C
D2	PROP. VAR. DEPTH ACIC, TYPE I19.0C
E1	PROP. APPROX. 4" ACBC, TYPE B25.0C
E2	PROP. APPROX. 7" ACBC, TYPE B25.0C
E3	PROP. VAR. DEPTH ACBC, TYPE B25.0C
J1	7" AGGREGATE BASE COURSE.
R1	2'-6" CONCRETE CURB AND GUTTER.
R2	1'-6" CONCRETE CURB AND GUTTER.
R3	2'-9" CONCRETE CURB AND GUTTER.
R4	5" MONOLITHIC CONCRETE ISLAND (KEYED IN).
S1	4" CONCRETE SIDEWALK.
T	EARTH MATERIAL.
U	EXISTING PAVEMENT.
V1	MILLING BITUMINOUS PAVEMENT 1.5".
V2	INCIDENTAL MILLING .
W	VARIABLE DEPTH ASPHALT PAVEMENT. (SEE DETAIL No. 1 SHOWING METHOD OF WEDGING)

NOTE: PAVEMENT EDGE SLOPES ARE 1:1 UNLESS SHOWN OTHERWISE.

HNTB HNTB NORTH CAROLINA, P.C.
 101 S. Tryon Street, Suite 3610
 Charlotte, North Carolina 28280
 NC License No: C-1554

PROJECT REFERENCE NO. U-5768	SHEET NO. 2A-6
RW SHEET NO.	
ROADWAY DESIGN ENGINEER	PAVEMENT DESIGN ENGINEER
INCOMPLETE PLANS DO NOT USE FOR R/W ACQUISITION	
DOCUMENT NOT CONSIDERED FINAL UNLESS ALL SIGNATURES COMPLETED	

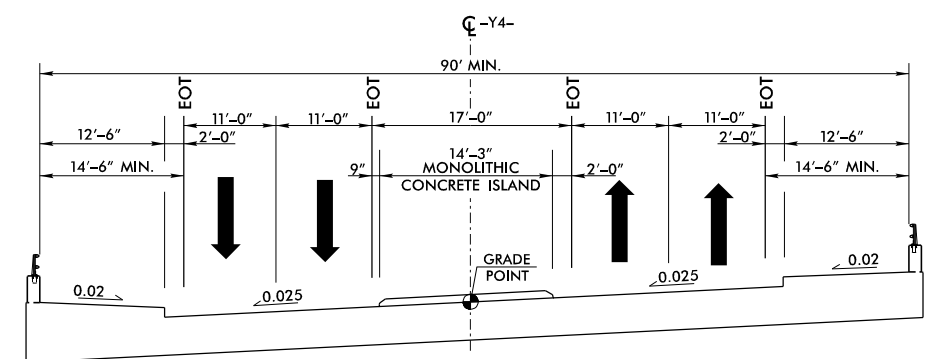

TYPICAL SECTION NO. 16
 -Y4- BACK CREEK CHURCH RD BRIDGE (NEW LOCATION)
 USE TYPICAL SECTION NO. 16
 -Y4- STA. 40+31 +/- (BEGIN BRIDGE) TO STA. 43+31 +/- (END BRIDGE)

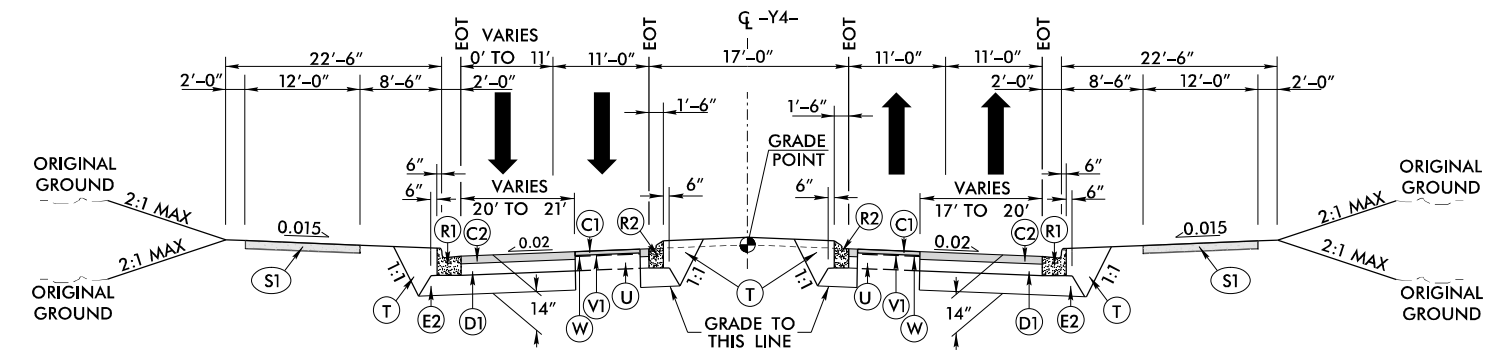

TYPICAL SECTION NO. 17
 -Y4- BACK CREEK CHURCH RD (NEW LOCATION)
 USE TYPICAL SECTION NO. 17
 -Y4- STA. 63+63.51 TO STA. 74+48.00

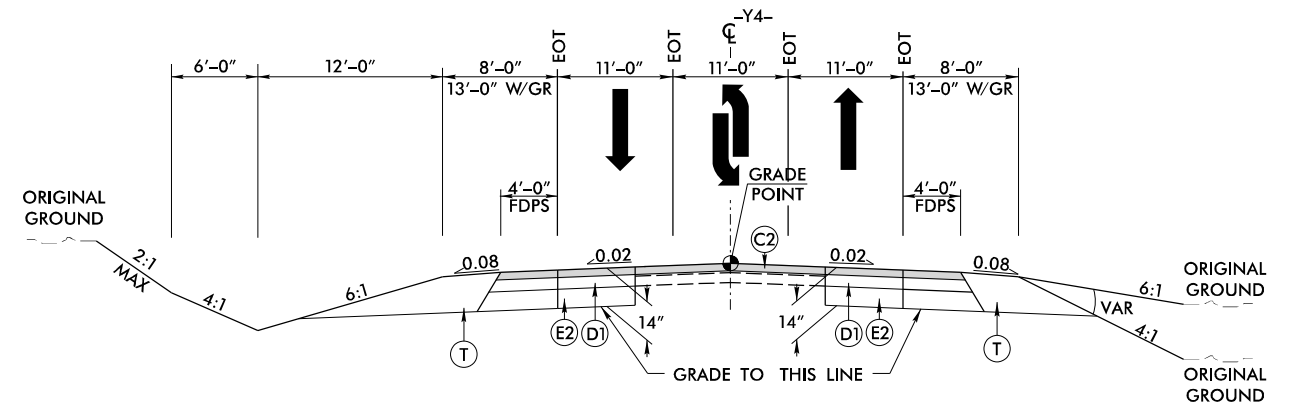

TYPICAL SECTION NO. 18
 -Y4- BACK CREEK CHURCH RD (NEW LOCATION)
 USE TYPICAL SECTION NO. 18
 -Y4- STA. 74+48.00 TO STA. 79+30.00

5/14/99

AWAITING FINAL PAVEMENT SCHEDULE	
C1	PROP. APPROX. 1.5" ACSC, TYPE S9.5C
C2	PROP. APPROX. 3" ACSC, TYPE S9.5C
C3	PROP. VAR. DEPTH ACSC, TYPE S9.5C
D1	PROP. APPROX. 4" ACIC, TYPE I19.0C
D2	PROP. VAR. DEPTH ACIC, TYPE I19.0C
E1	PROP. APPROX. 4" ACBC, TYPE B25.0C
E2	PROP. APPROX. 7" ACBC, TYPE B25.0C
E3	PROP. VAR. DEPTH ACBC, TYPE B25.0C
J1	7" AGGREGATE BASE COURSE.
R1	2'-6" CONCRETE CURB AND GUTTER.
R2	1'-6" CONCRETE CURB AND GUTTER.
R3	2'-9" CONCRETE CURB AND GUTTER.
R4	5" MONOLITHIC CONCRETE ISLAND (KEYED IN).
S1	4" CONCRETE SIDEWALK.
T	EARTH MATERIAL.
U	EXISTING PAVEMENT.
V1	MILLING BITUMINOUS PAVEMENT 1.5".
V2	INCIDENTAL MILLING .
W	VARIABLE DEPTH ASPHALT PAVEMENT. (SEE DETAIL No. 1 SHOWING METHOD OF WEDGING)

NOTE: PAVEMENT EDGE SLOPES ARE 1:1 UNLESS SHOWN OTHERWISE.

70-AUG-2001 09:55
C:\p05\p1\c01\5768.RDY_TYP.dgn

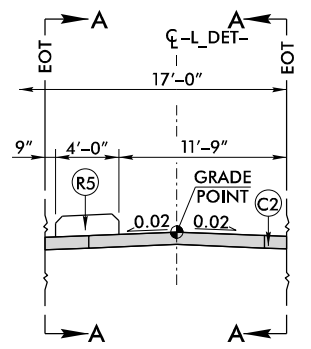

DETAIL 32A
MONOLITHIC ISLAND LOCATIONS
USE IN CONJUNCTION WITH TYPICAL SECTION 32

PROJECT REFERENCE NO. U-5768	SHEET NO. 2A-10
RW SHEET NO.	
ROADWAY DESIGN ENGINEER	PAVEMENT DESIGN ENGINEER
INCOMPLETE PLANS DO NOT USE FOR R/W ACQUISITION	
DOCUMENT NOT CONSIDERED FINAL UNLESS ALL SIGNATURES COMPLETED	

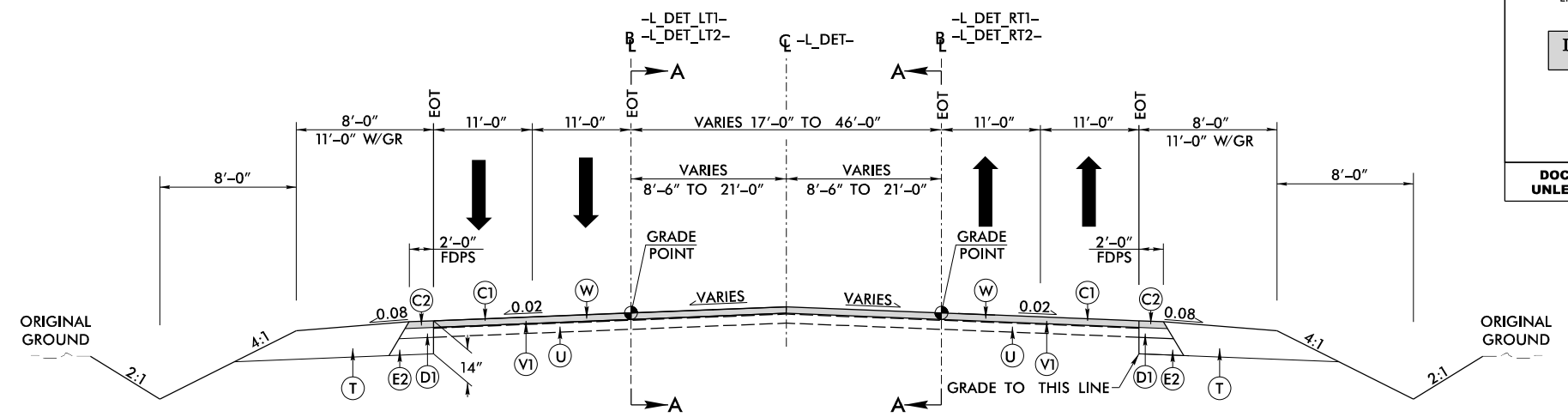

TYPICAL SECTION NO. 32
-L_DET-, -L_DET_LTI-, -L_DET_LT2-, -L_DET_RT1- & -L_DET_RT2- DETOUR
USE TYPICAL SECTION NO. 32
-L_DET- STA. 10+00.00 TO STA. 14+00.00 +/-
-L_DET- STA. 38+00.00 TO STA. 40+00.00

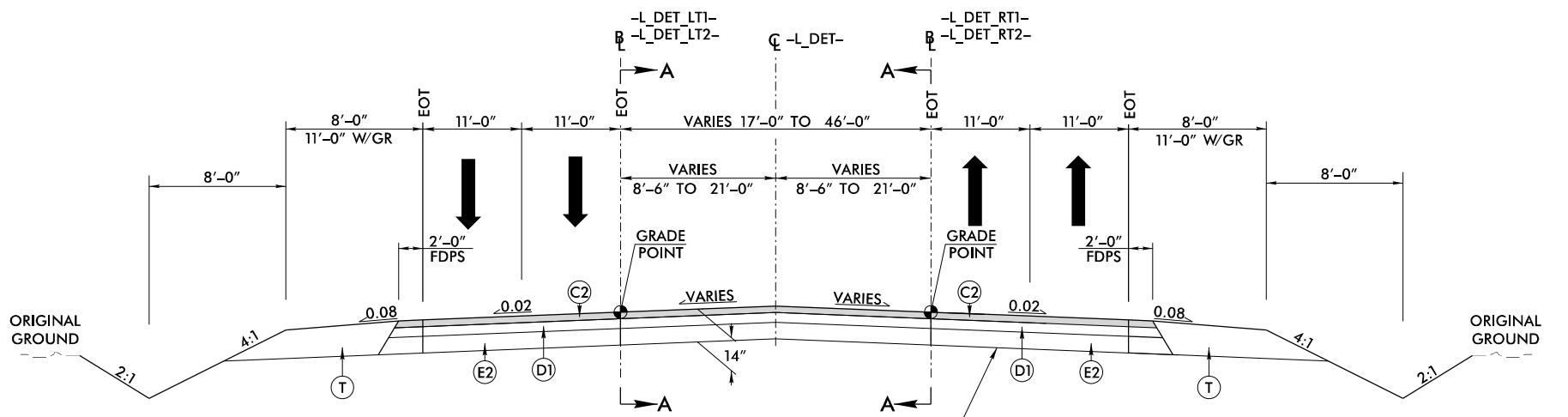

TYPICAL SECTION NO. 33
-L_DET-, -L_DET_LTI-, -L_DET_LT2-, -L_DET_RT1- & -L_DET_RT2- DETOUR
USE TYPICAL SECTION NO. 33
-L_DET- STA. 14+00.00 +/- TO STA. 38+00.00 +/-

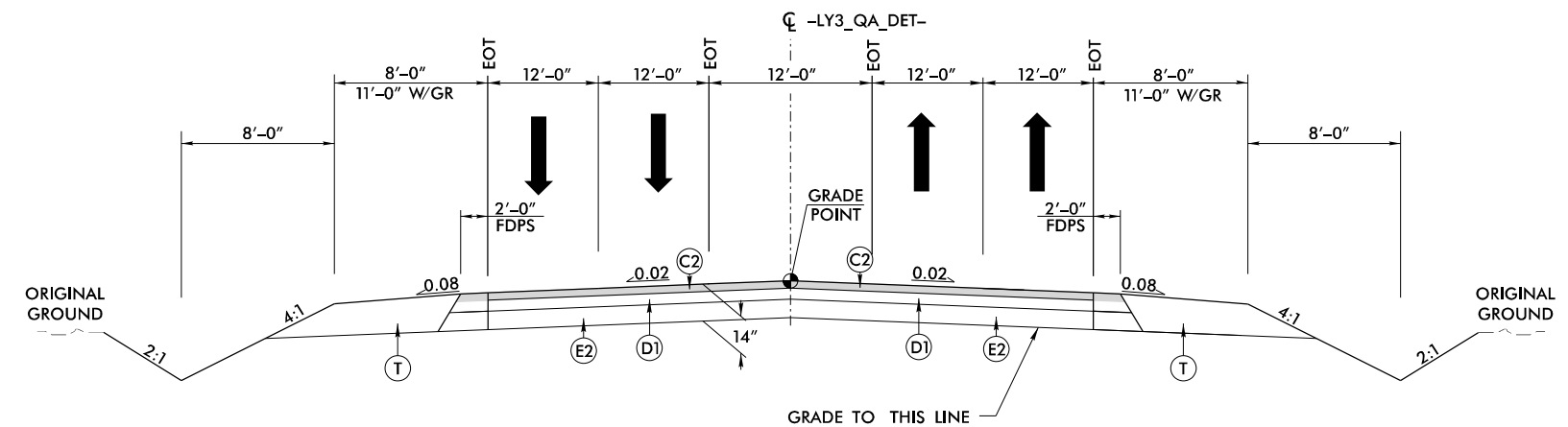

TYPICAL SECTION NO. 34
-LY3_QA_DET- QUADRANT A DETOUR
USE TYPICAL SECTION NO. 34
-LY3_QC_DET- STA. 10+00.00 TO STA. 12+27.73

5/14/99

PROJECT REFERENCE NO. U-5768	SHEET NO. 4
RW SHEET NO.	
ROADWAY DESIGN ENGINEER	HYDRAULICS ENGINEER
INCOMPLETE PLANS DO NOT USE FOR R/W ACQUISITION	
DOCUMENT NOT CONSIDERED FINAL UNLESS ALL SIGNATURES COMPLETED	

NO JURISDICTIONAL RESOURCES IMPACTED ON THIS PAGE.

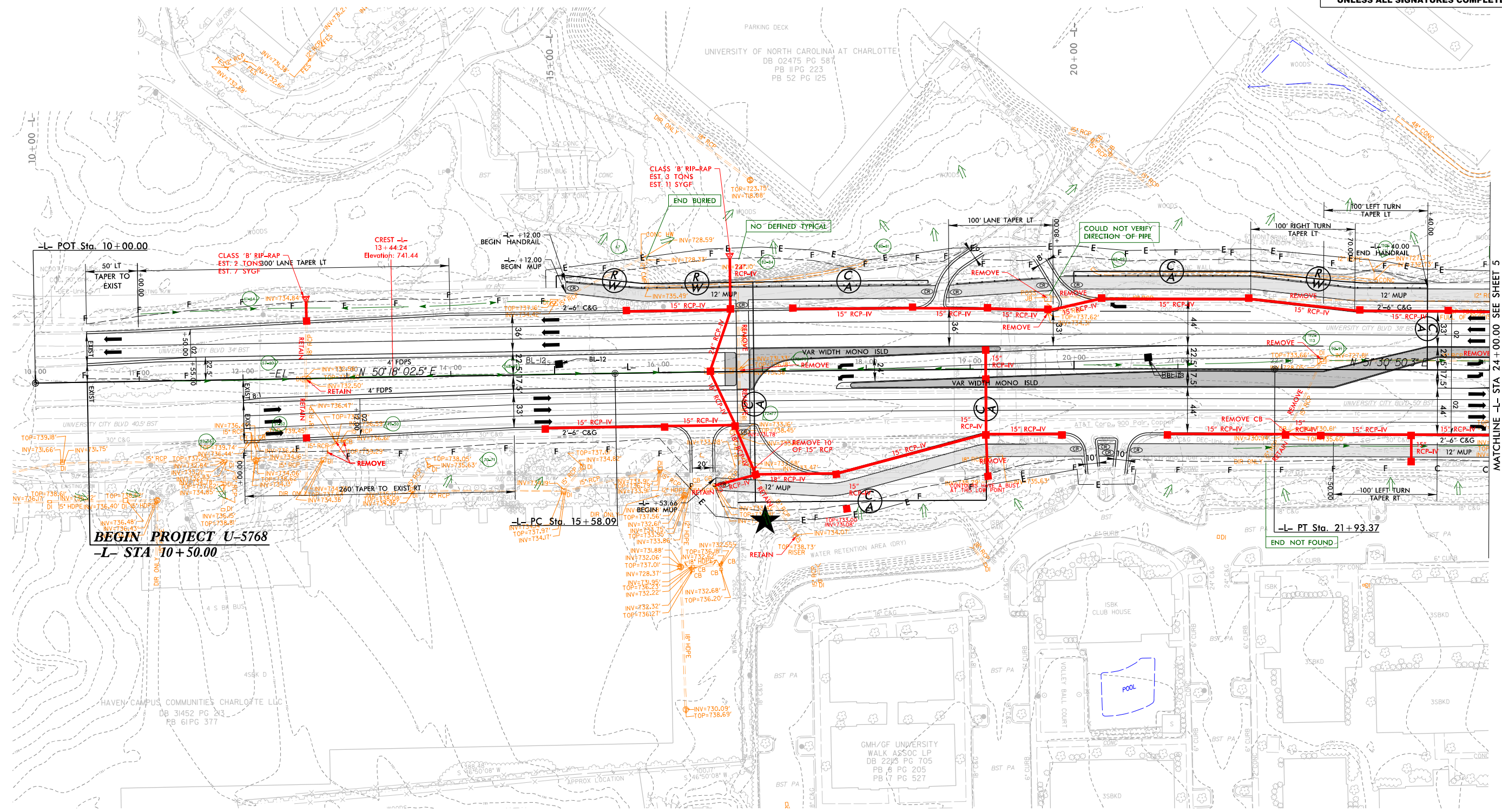
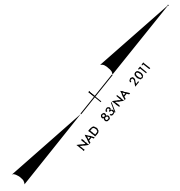

BEGIN PROJECT U-5768
 -L- STA 10+50.00

-L- PT Sta. 21+93.37
 END NOT FOUND

MATCHLINE -L- STA 24+00.00 SEE SHEET 5

- NOTES:**
1. ALL DRIVEWAY RADII ARE 20' UNLESS OTHERWISE NOTED
 2. FOR -L- INTERSECTION DETAILS, SEE SHEET 2B-1
 3. FOR -L- PROFILE, SEE SHEET 18

306105_PSR_U-5768_HYD_PSH4.dgn

PROJECT REFERENCE NO.	SHEET NO.
U-5768	5
RW SHEET NO.	
ROADWAY DESIGN ENGINEER	HYDRAULICS ENGINEER
INCOMPLETE PLANS DO NOT USE FOR R/W ACQUISITION	
DOCUMENT NOT CONSIDERED FINAL UNLESS ALL SIGNATURES COMPLETED	

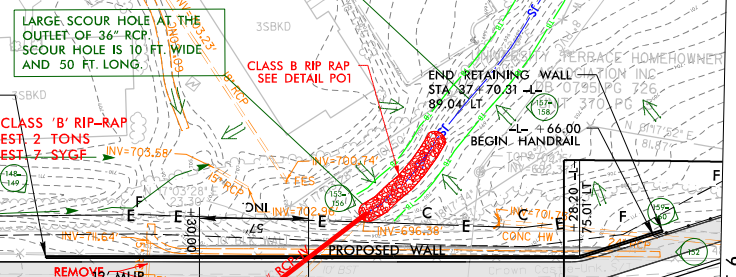
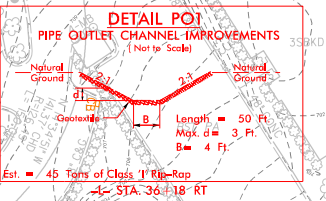
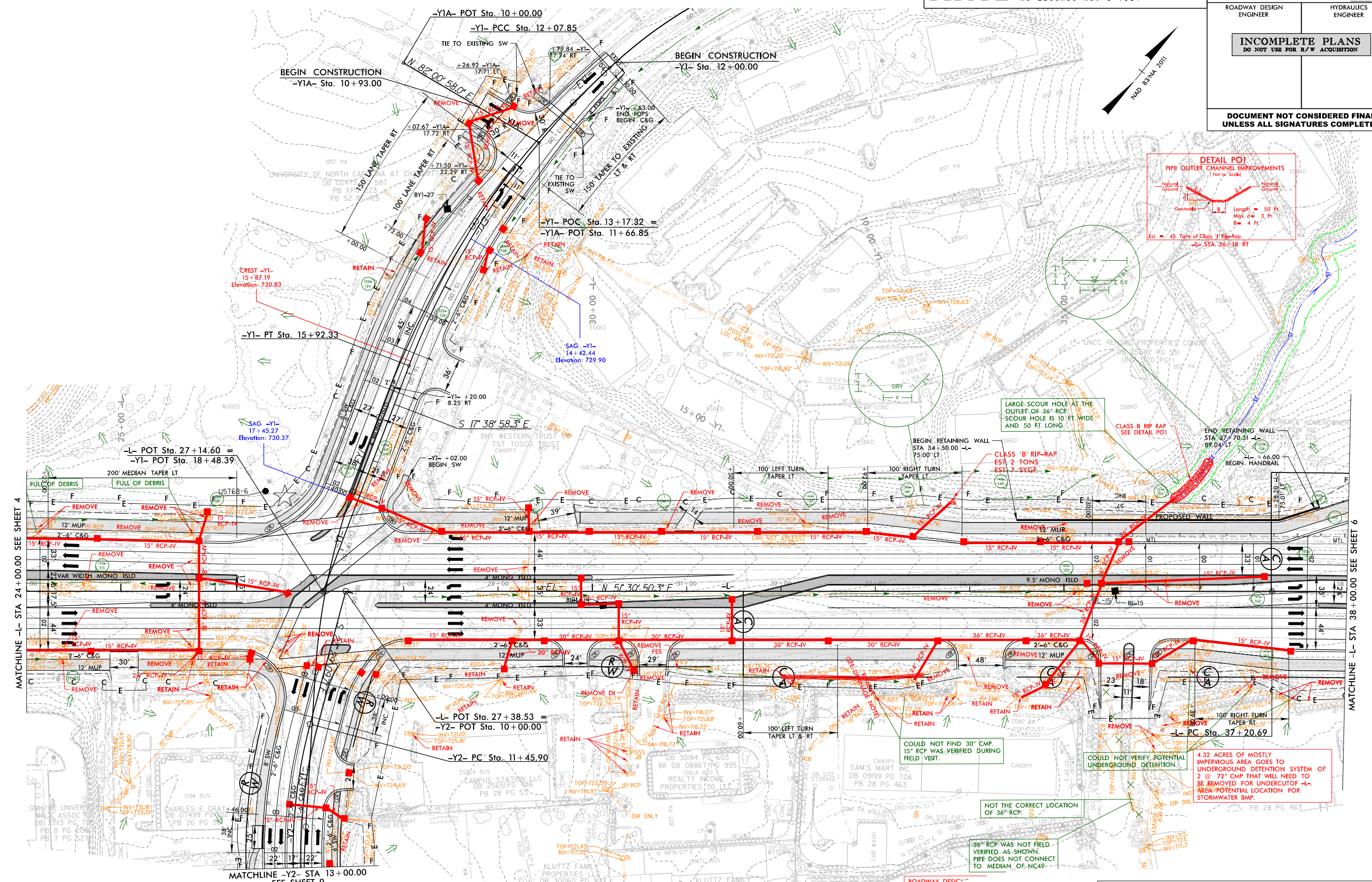

4.32 ACRES OF MOSTLY IMPERVIOUS AREA GOES TO UNDERGROUND DETENTION SYSTEM OF 2 @ 75' CMP THAT WILL NEED TO BE REMOVED FOR UNDERCUT OF 4'-AREA/POTENTIAL LOCATION FOR STORMWATER BMP.

NOT THE CORRECT LOCATION OF 36\"/>

36\"/>

- NOTES:**
1. ALL DRIVEWAY RADII ARE 20' UNLESS OTHERWISE NOTED
 2. FOR -L-, -Y1- & -Y2- INTERSECTION DETAILS, SEE SHEET 2B-2
 3. FOR -L- PROFILE, SEE SHEET 18
 4. FOR -Y1- PROFILE, SEE SHEET 22
 5. FOR -Y1A- PROFILE, SEE SHEET 22
 6. FOR -Y2- PROFILE, SEE SHEET 22

PROJECT REFERENCE NO.	SHEET NO.
U-5768	6
RW SHEET NO.	
ROADWAY DESIGN ENGINEER	HYDRAULICS ENGINEER
INCOMPLETE PLANS DO NOT USE FOR R/W ACQUISITION	
DOCUMENT NOT CONSIDERED FINAL UNLESS ALL SIGNATURES COMPLETED	

NO JURISDICTIONAL RESOURCES IMPACTED ON THIS PAGE.

DRAINAGE DESIGNS FOR QUADRANT SUBJECT TO CHANGE DUE TO ONGOING CONSTRUCTION BY OTHERS THERE ARE NO IMPACTS TO WATERS OF THE STATE.

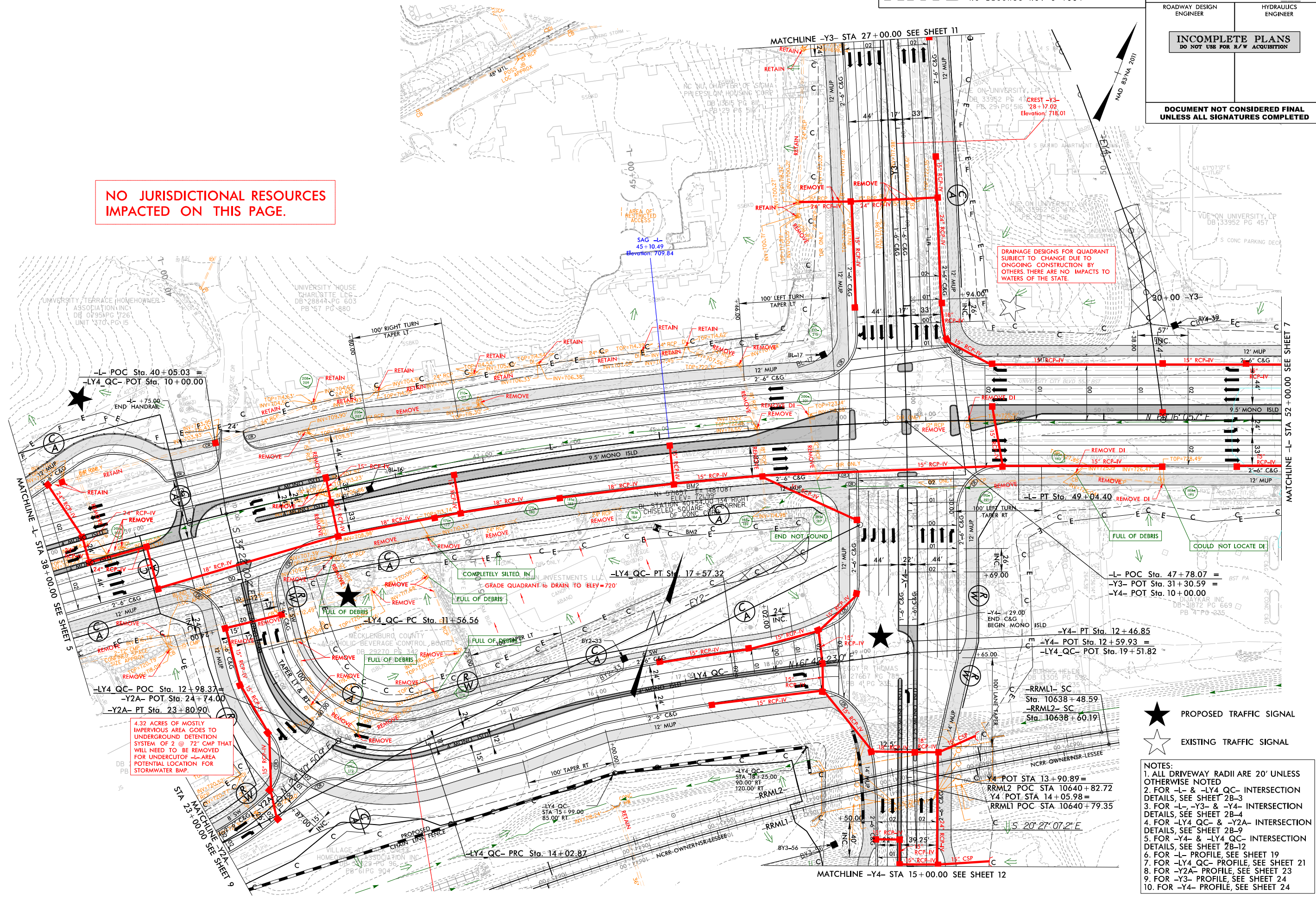

-L- POC Sta. 40+05.03 =
-LY4 QC- POT Sta. 10+00.00

-LY4 QC- POC Sta. 12+98.37 =
-Y2A- POT Sta. 24+74.00
-Y2A- PT Sta. 23+80.90

4.32 ACRES OF MOSTLY IMPERVIOUS AREA GOES TO UNDERGROUND DETENTION SYSTEM OF 2 @ 72" CMP THAT WILL NEED TO BE REMOVED FOR UNDERCUT OF -L- AREA POTENTIAL LOCATION FOR STORMWATER BMP.

-L- POC Sta. 47+78.07 =
-Y3- POT Sta. 31+30.59 =
-Y4- POT Sta. 10+00.00

-Y4- PT Sta. 12+46.85
-Y4- POT Sta. 12+59.93 =
-LY4 QC- POT Sta. 19+51.82

-RRML1- SC
Sta. 10638+48.59
-RRML2- SC
Sta. 10638+60.19

-Y4 POT STA 13+90.89 =
RRML2 POC STA 10640+82.72
Y4 POT STA 14+05.98 =
RRML1 POC STA 10640+79.35

-LY4 QC- PRC Sta. 14+02.87

MATCHLINE -Y4- STA 15+00.00 SEE SHEET 12

MATCHLINE -L- STA 38+00.00 SEE SHEET 5

MATCHLINE -Y3- STA 27+00.00 SEE SHEET 11

MATCHLINE -L- STA 52+00.00 SEE SHEET 7

- ★ PROPOSED TRAFFIC SIGNAL
- ☆ EXISTING TRAFFIC SIGNAL

- NOTES:
1. ALL DRIVEWAY RADII ARE 20' UNLESS OTHERWISE NOTED
 2. FOR -L- & -LY4 QC- INTERSECTION DETAILS, SEE SHEET 2B-3
 3. FOR -L-, -Y3- & -Y4- INTERSECTION DETAILS, SEE SHEET 2B-4
 4. FOR -LY4 QC- & -Y2A- INTERSECTION DETAILS, SEE SHEET 2B-9
 5. FOR -Y4- & -LY4 QC- INTERSECTION DETAILS, SEE SHEET 2B-12
 6. FOR -L- PROFILE, SEE SHEET 19
 7. FOR -LY4 QC- PROFILE, SEE SHEET 21
 8. FOR -Y2A- PROFILE, SEE SHEET 23
 9. FOR -Y3- PROFILE, SEE SHEET 24
 10. FOR -Y4- PROFILE, SEE SHEET 24

PROJECT REFERENCE NO.	SHEET NO.
U-5768	7
RW SHEET NO.	
ROADWAY DESIGN ENGINEER	HYDRAULICS ENGINEER
INCOMPLETE PLANS DO NOT USE FOR R/W ACQUISITION	
DOCUMENT NOT CONSIDERED FINAL UNLESS ALL SIGNATURES COMPLETED	

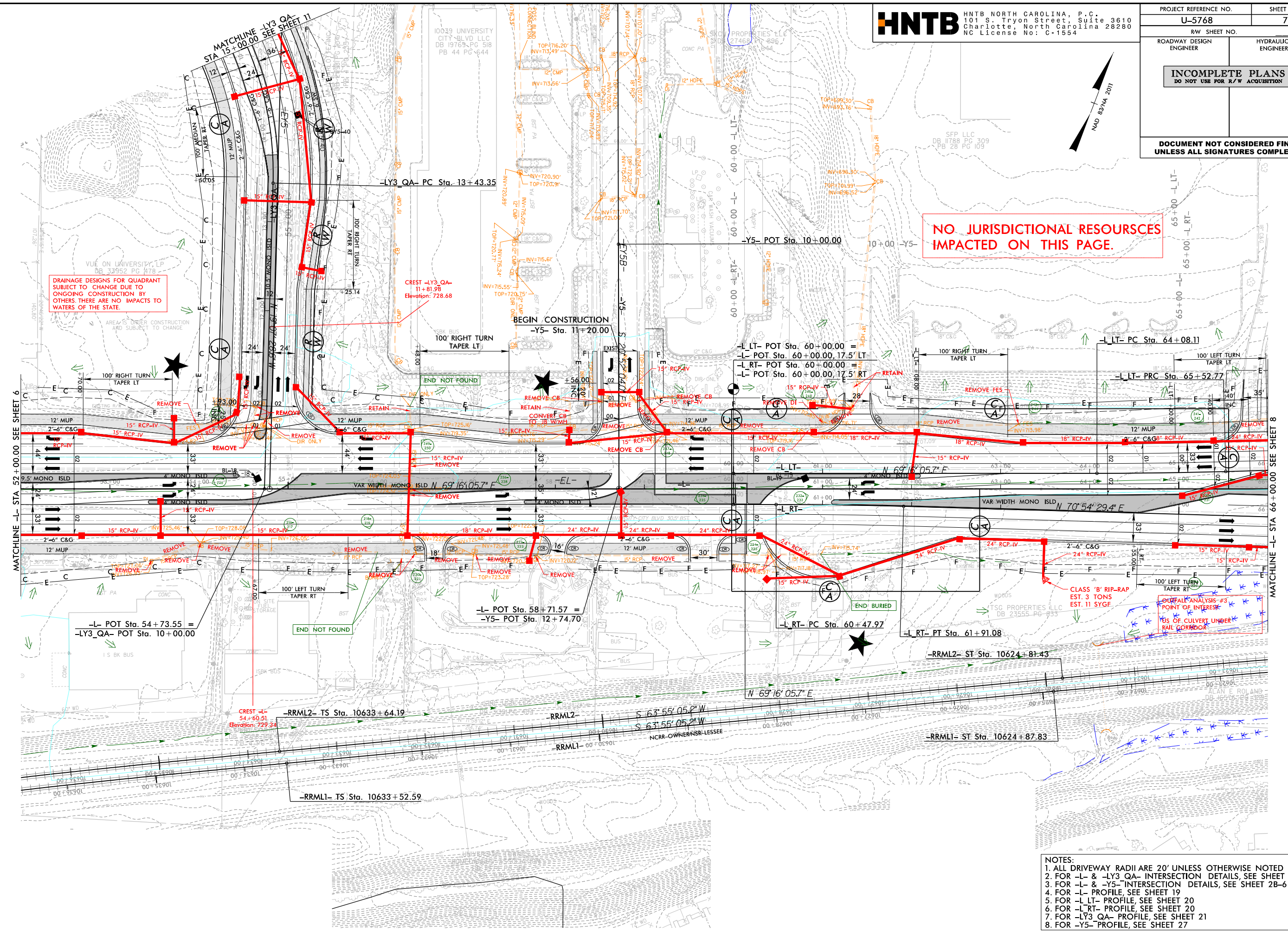

DRAINAGE DESIGNS FOR QUADRANT SUBJECT TO CHANGE DUE TO ONGOING CONSTRUCTION BY OTHERS. THERE ARE NO IMPACTS TO WATERS OF THE STATE.

NO JURISDICTIONAL RESOURCES IMPACTED ON THIS PAGE.

- NOTES:
1. ALL DRIVEWAY RADII ARE 20' UNLESS OTHERWISE NOTED
 2. FOR -L- & -LY3 QA- INTERSECTION DETAILS, SEE SHEET 2B-5
 3. FOR -L- & -Y5- INTERSECTION DETAILS, SEE SHEET 2B-6
 4. FOR -L- PROFILE, SEE SHEET 19
 5. FOR -L LT- PROFILE, SEE SHEET 20
 6. FOR -L RT- PROFILE, SEE SHEET 20
 7. FOR -LY3 QA- PROFILE, SEE SHEET 21
 8. FOR -Y5- PROFILE, SEE SHEET 27

PROJECT REFERENCE NO.	SHEET NO.
U-5768	8
RW SHEET NO.	
ROADWAY DESIGN ENGINEER	HYDRAULICS ENGINEER
INCOMPLETE PLANS DO NOT USE FOR R/W ACQUISITION	
DOCUMENT NOT CONSIDERED FINAL UNLESS ALL SIGNATURES COMPLETED	

NO JURISDICTIONAL RESOURCES IMPACTED ON THIS PAGE.

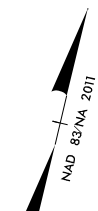
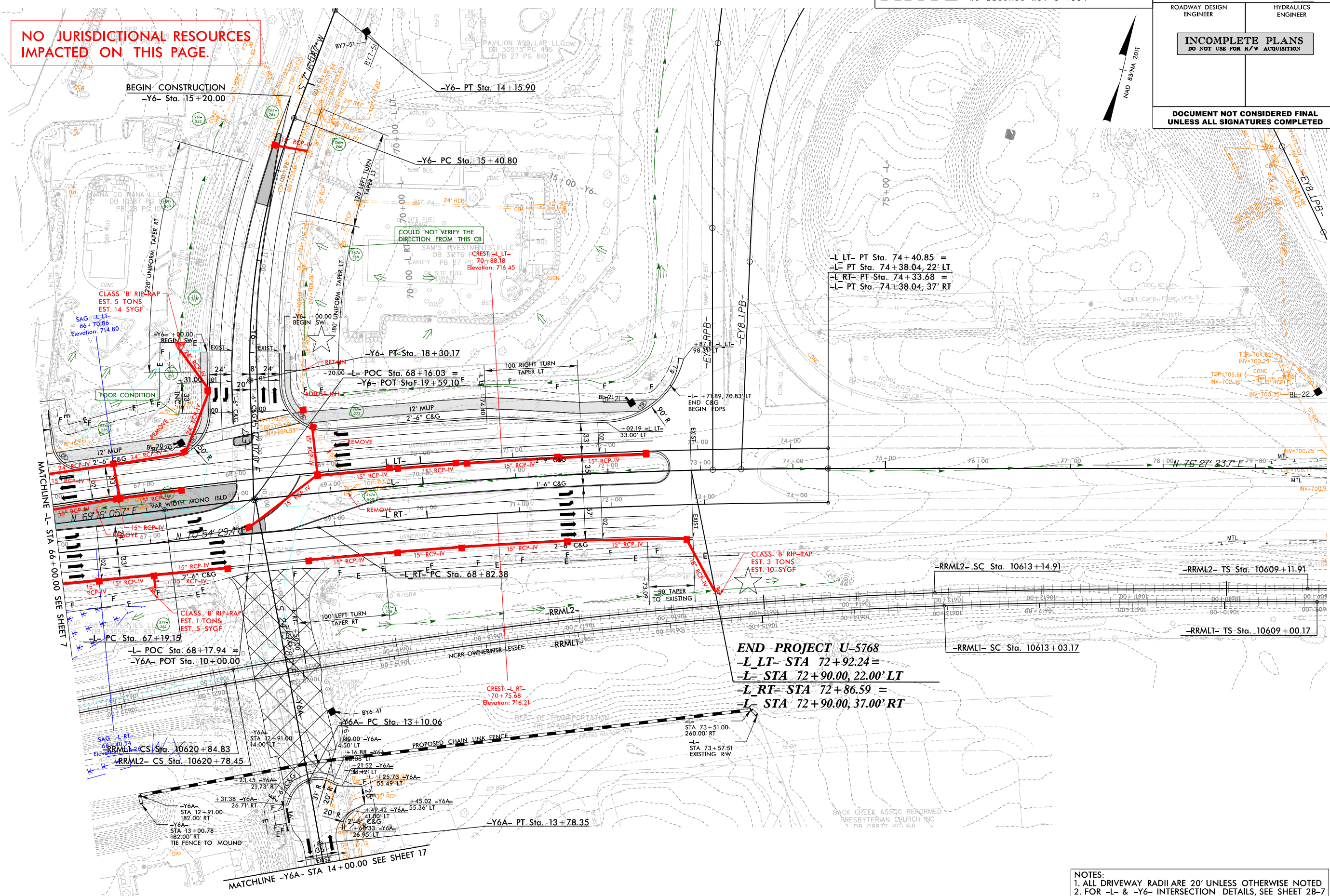

-L- LT- PT Sta. 74+40.85 =
 -L- PT Sta. 74+38.04, 22' LT
 -L- RT- PT Sta. 74+33.68 =
 -L- PT Sta. 74+38.04, 37' RT

END PROJECT U-5768
 -L- LT- STA 72+92.24 =
 -L- STA 72+90.00, 22.00' LT
 -L- RT- STA 72+86.59 =
 -L- STA 72+90.00, 37.00' RT

- NOTES:
1. ALL DRIVEWAY RADII ARE 20' UNLESS OTHERWISE NOTED
 2. FOR -L- & -Y6- INTERSECTION DETAILS, SEE SHEET 2B-7
 3. FOR -L- LT- PROFILE, SEE SHEET 20
 4. FOR -L- RT- PROFILE, SEE SHEET 20
 5. FOR -Y6- PROFILE, SEE SHEET 27
 6. FOR -Y6A- PROFILE, SEE SHEET 27

PROJECT REFERENCE NO.	SHEET NO.
U-5768	9
RW SHEET NO.	
ROADWAY DESIGN ENGINEER	HYDRAULICS ENGINEER
INCOMPLETE PLANS DO NOT USE FOR R/W ACQUISITION	
DOCUMENT NOT CONSIDERED FINAL UNLESS ALL SIGNATURES COMPLETED	

NO JURISDICTIONAL RESOURCES IMPACTED ON THIS PAGE.

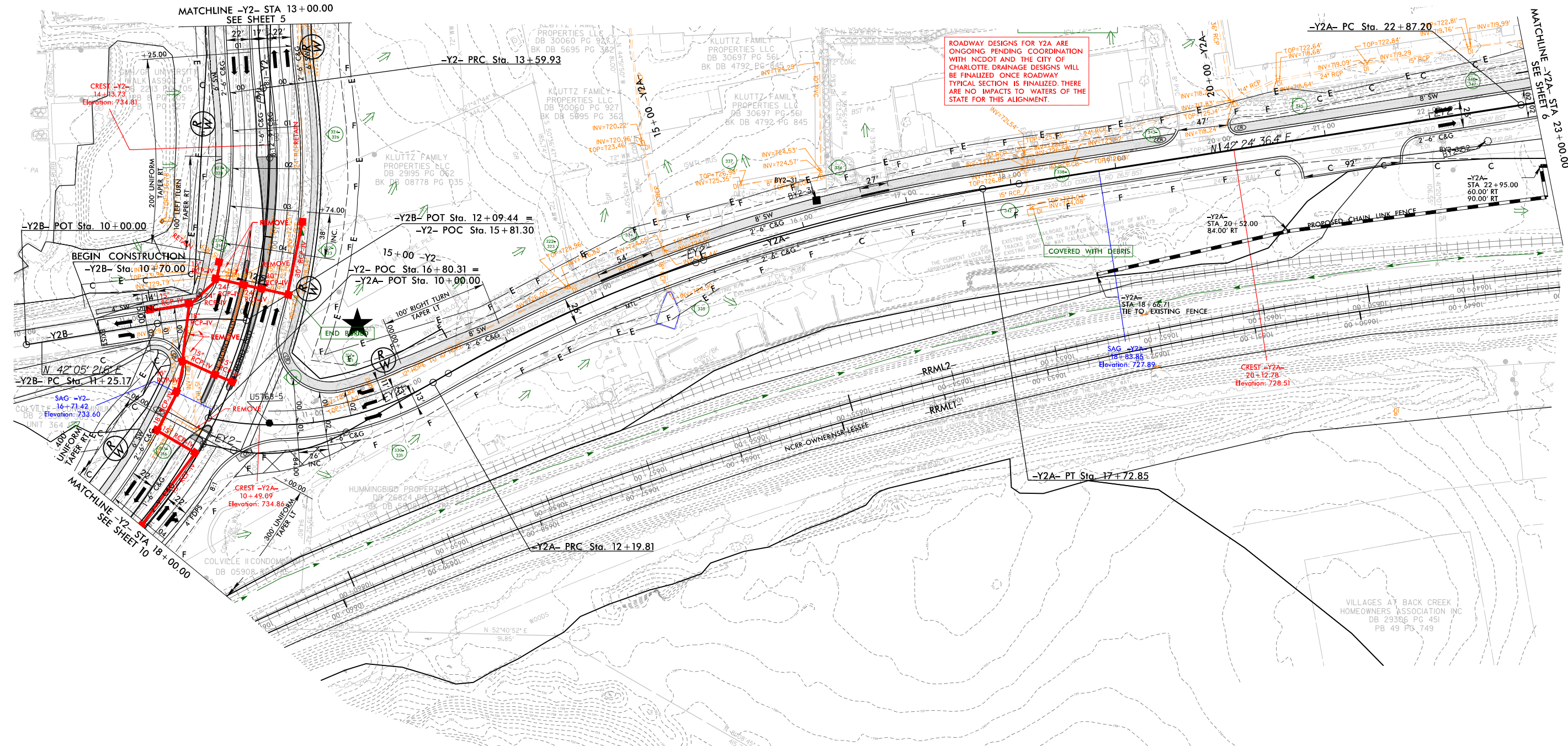
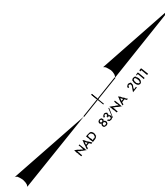

ROADWAY DESIGNS FOR Y2A ARE ONGOING PENDING COORDINATION WITH NCDOT AND THE CITY OF CHARLOTTE. DRAINAGE DESIGNS WILL BE FINALIZED ONCE ROADWAY TYPICAL SECTION IS FINALIZED. THERE ARE NO IMPACTS TO WATERS OF THE STATE FOR THIS ALIGNMENT.

- NOTES:
1. ALL DRIVEWAY RADII ARE 20' UNLESS OTHERWISE NOTED
 2. FOR -Y2- & -Y2A- INTERSECTION DETAILS, SEE SHEET 28-8
 3. FOR -Y2- PROFILE, SEE SHEET 22
 4. FOR -Y2A- PROFILE, SEE SHEET 23
 5. FOR -Y2B- PROFILE, SEE SHEET 23

PROJECT REFERENCE NO.	SHEET NO.
U-5768	10
RW SHEET NO.	
ROADWAY DESIGN ENGINEER	HYDRAULICS ENGINEER
INCOMPLETE PLANS DO NOT USE FOR R/W ACQUISITION	
DOCUMENT NOT CONSIDERED FINAL UNLESS ALL SIGNATURES COMPLETED	

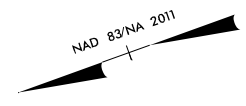

NO JURISDICTIONAL RESOURCES IMPACTED ON THIS PAGE.

-Y2-
 PI Sta 17+08.14
 $\Delta = 66^{\circ}18'45.1''$ (RT)
 $D = 10^{\circ}44'58.8''$
 $L = 616.88'$
 $T = 348.20'$
 $R = 533.00'$
 $SE = 4\%$
 $RO = 152'$
 $V = 40$ MPH

5/14/99

30-AUG-2021 09:57:66_HYD_PSH10.dgn

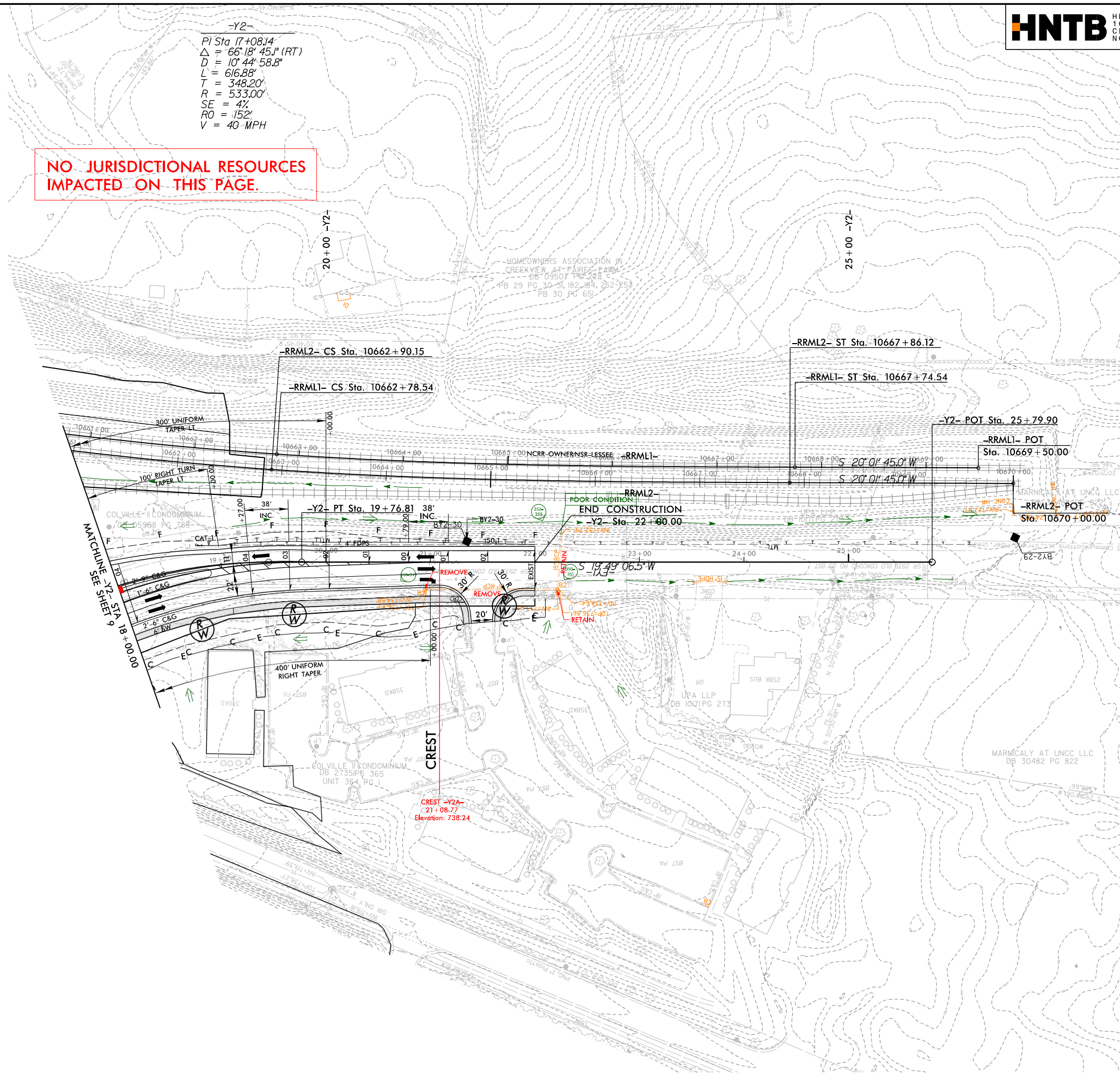

- NOTES:
 1. ALL DRIVEWAY RADII ARE 20' UNLESS OTHERWISE NOTED
 2. FOR -Y2- PROFILE, SEE SHEET 22

PROJECT REFERENCE NO.	SHEET NO.
U-5768	11
RW SHEET NO.	
ROADWAY DESIGN ENGINEER	HYDRAULICS ENGINEER
INCOMPLETE PLANS DO NOT USE FOR R/W ACQUISITION	
DOCUMENT NOT CONSIDERED FINAL UNLESS ALL SIGNATURES COMPLETED	

NO JURISDICTIONAL RESOURCES IMPACTED ON THIS PAGE.

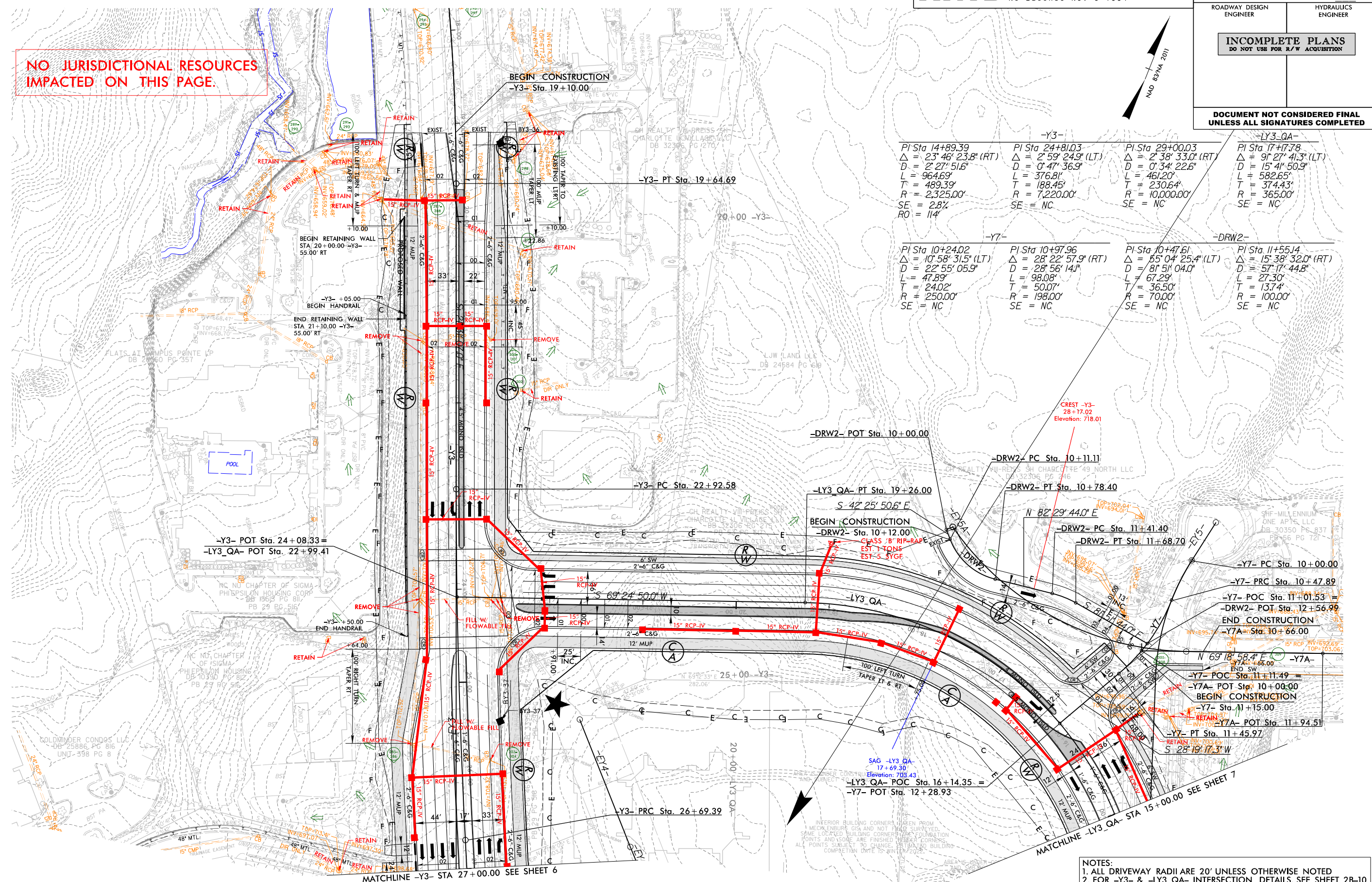
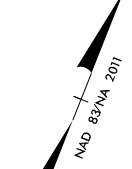

-Y3-		-LY3 QA-	
PI Sta 14+89.39	PI Sta 24+81.03	PI Sta 29+00.03	PI Sta 17+17.78
$\Delta = 23' 46'' 23.8''$ (RT)	$\Delta = 2' 59'' 24.9''$ (LT)	$\Delta = 2' 38'' 33.0''$ (RT)	$\Delta = 9' 27'' 41.3''$ (LT)
$D = 2' 27'' 51.6''$	$D = 0' 47'' 36.9''$	$D = 0' 34'' 22.6''$	$D = 15' 4'' 50.9''$
$L = 964.69'$	$L = 376.81'$	$L = 461.20'$	$L = 582.65'$
$T = 489.39'$	$T = 188.45'$	$T = 230.64'$	$T = 374.43'$
$R = 2,325.00'$	$R = 7,220.00'$	$R = 10,000.00'$	$R = 365.00'$
$SE = 2.8\%$	$SE = NC$	$SE = NC$	$SE = NC$
$RO = 114'$			

-Y7-		-DRW2-	
PI Sta 10+24.02	PI Sta 10+97.96	PI Sta 10+47.61	PI Sta 11+55.14
$\Delta = 10' 58'' 31.5''$ (LT)	$\Delta = 28' 22'' 57.9''$ (RT)	$\Delta = 55' 04'' 25.4''$ (LT)	$\Delta = 15' 38'' 32.0''$ (RT)
$D = 22' 55'' 05.9''$	$D = 28' 56'' 14.1''$	$D = 81' 51'' 04.0''$	$D = 57' 17'' 44.8''$
$L = 47.89'$	$L = 98.08'$	$L = 67.29'$	$L = 27.30'$
$T = 24.02'$	$T = 50.07'$	$T = 36.50'$	$T = 13.74'$
$R = 250.00'$	$R = 198.00'$	$R = 70.00'$	$R = 100.00'$
$SE = NC$	$SE = NC$	$SE = NC$	$SE = NC$

- NOTES:**
1. ALL DRIVEWAY RADII ARE 20' UNLESS OTHERWISE NOTED
 2. FOR -Y3- & -LY3 QA- INTERSECTION DETAILS, SEE SHEET 2B-10
 3. FOR -LY3 QA- & -Y7- INTERSECTION DETAILS, SEE SHEET 2B-11
 4. FOR -LY3 QA- PROFILE, SEE SHEET 21
 5. FOR -Y3- PROFILE, SEE SHEET 24
 6. FOR -Y7- PROFILE, SEE SHEET 27
 7. FOR -Y7A- PROFILE, SEE SHEET 27
 8. FOR -DRW2- PROFILE, SEE SHEET 30

5/14/99

PROJECT REFERENCE NO.	SHEET NO.
U-5768	12
RW SHEET NO.	
ROADWAY DESIGN ENGINEER	HYDRAULICS ENGINEER
INCOMPLETE PLANS DO NOT USE FOR R/W ACQUISITION	
DOCUMENT NOT CONSIDERED FINAL UNLESS ALL SIGNATURES COMPLETED	

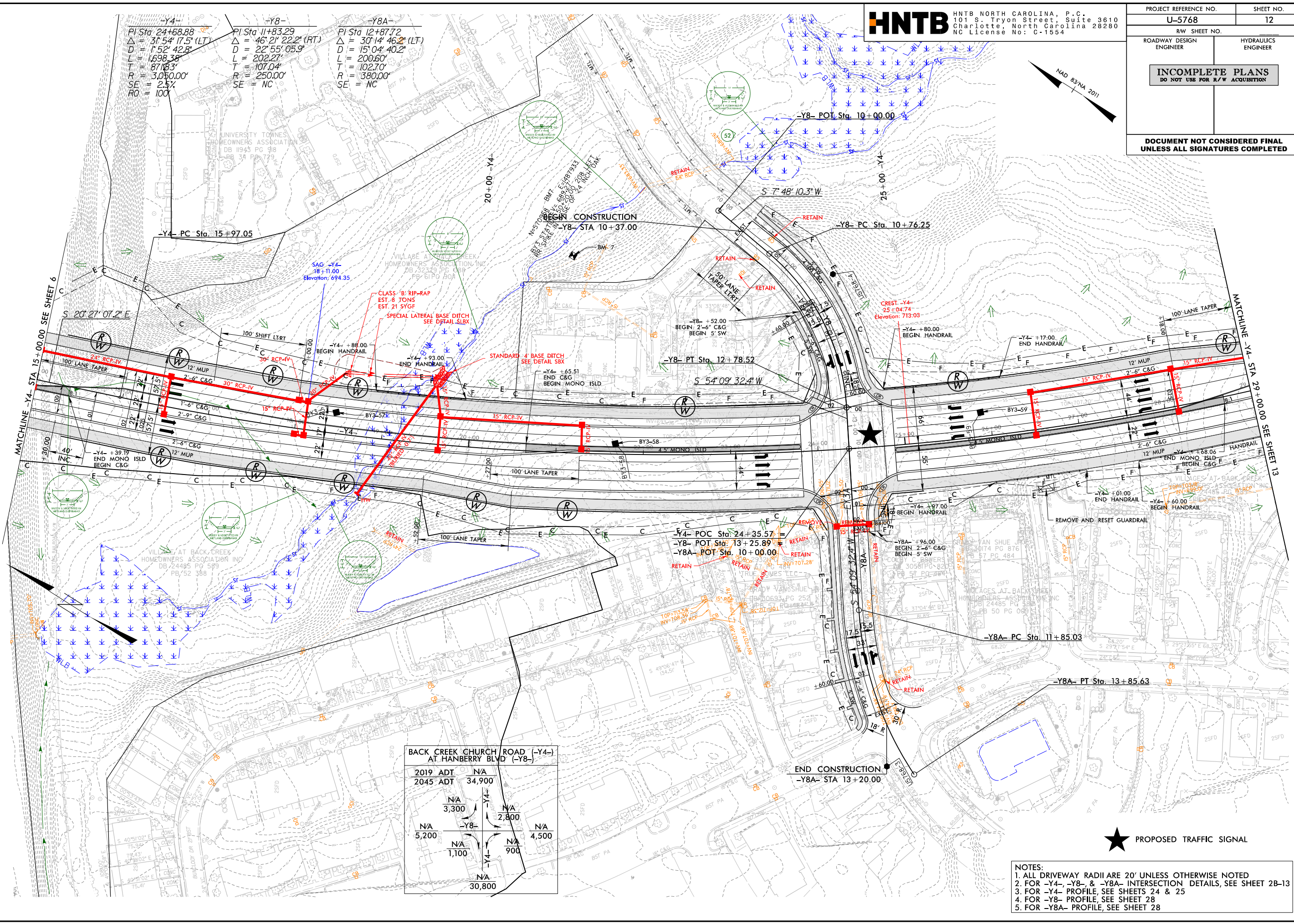

-Y4-	-Y8-	-Y8A-
PI Sta 24+68.88	PI Sta 11+83.29	PI Sta 12+87.72
$\Delta = 31^{\circ}54'17.5"$ (LT)	$\Delta = 46^{\circ}21'22.2"$ (RT)	$\Delta = 30^{\circ}14'46.2"$ (LT)
D = 152'42.8'	D = 22'55'05.9"	D = 15'04'40.2"
L = 1698.38'	L = 202.27'	L = 200.60'
T = 871.83'	T = 107.04'	T = 102.70'
R = 3,050.00'	R = 250.00'	R = 380.00'
SE = 2.5%	SE = NC	SE = NC
RO = 100'		

BACK CREEK CHURCH ROAD (-Y4-) AT HANBERRY BLVD (-Y8-)

2019 ADT	N/A
2045 ADT	34,900
	N/A
	3,300
	N/A
	2,800
	N/A
	5,200
	N/A
	1,100
	N/A
	900
	N/A
	30,800

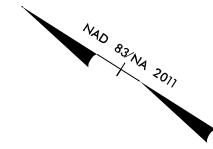

- NOTES:
- ALL DRIVEWAY RADII ARE 20' UNLESS OTHERWISE NOTED
 - FOR -Y4-, -Y8-, & -Y8A- INTERSECTION DETAILS, SEE SHEET 2B-13
 - FOR -Y4- PROFILE, SEE SHEETS 24 & 25
 - FOR -Y8- PROFILE, SEE SHEET 28
 - FOR -Y8A- PROFILE, SEE SHEET 28

306405_PSR_U95768_HYD_PSH12.dgn
 DATE: 05/14/99

PROJECT REFERENCE NO.	SHEET NO.
U-5768	13
RW SHEET NO.	
ROADWAY DESIGN ENGINEER	HYDRAULICS ENGINEER
INCOMPLETE PLANS DO NOT USE FOR R/W ACQUISITION	
DOCUMENT NOT CONSIDERED FINAL UNLESS ALL SIGNATURES COMPLETED	

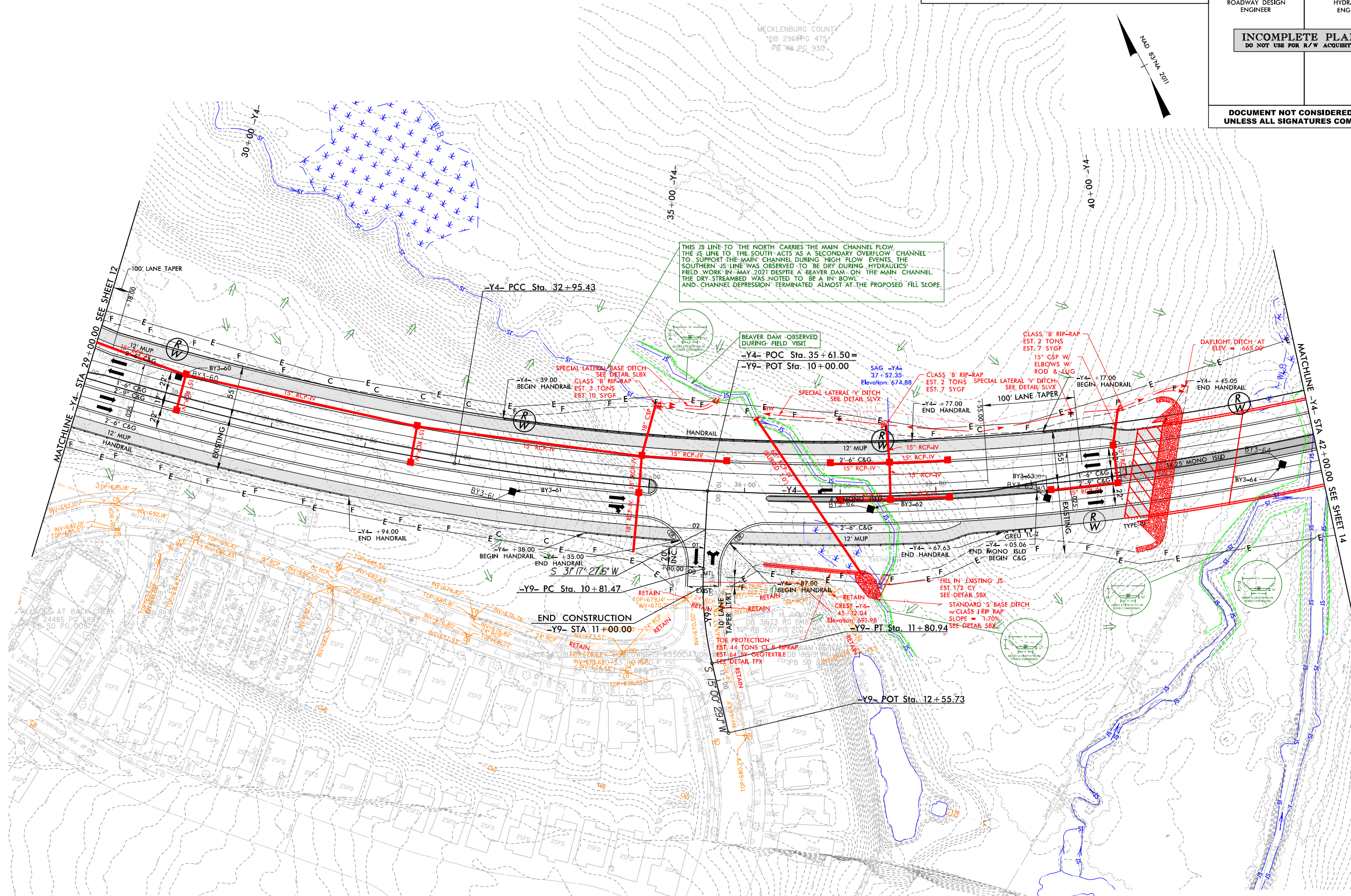
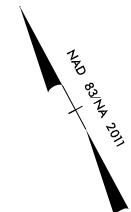

THIS IS LINE TO THE NORTH CARRIES THE MAIN CHANNEL FLOW. THE IS LINE TO THE SOUTH ACTS AS A SECONDARY OVERFLOW CHANNEL TO SUPPORT THE MAIN CHANNEL DURING HIGH FLOW EVENTS. THE SOUTHERN IS LINE WAS OBSERVED TO BE DRY DURING HYDRAULICS FIELD WORK IN MAY 2021 DESPITE A BEAVER DAM ON THE MAIN CHANNEL. THE DRY STREAMBED WAS NOTED TO BE A 'BOWL' AND CHANNEL DEPRESSION TERMINATED ALMOST AT THE PROPOSED FILL SLOPE.

BEAVER DAM - OBSERVED DURING FIELD VISIT
-Y4- POC Sta. 35+61.50 =
-Y9- POT Sta. 10+00.00

CLASS 'B' RIP-RAP EST. 2 TONS EST. 7 SYGF
15" CSP W/ ELBOWS W/ ROD & LUG

DAYLIGHT DITCH AT ELEV. = 665.00

SPECIAL LATERAL BASE DITCH SEE DETAIL SLVX
CLASS 'B' RIP-RAP EST. 3 TONS EST. 10 SYGF

SAG -Y4- 37+52.35 Elevation: 674.88

CLASS 'B' RIP-RAP EST. 2 TONS EST. 7 SYGF
SPECIAL LATERAL 'V' DITCH SEE DETAIL SLVX

TOP=695.18'
INV=692.07'
TOP=695.01'
INV=692.18'

-Y4- +94.00 END HANDRAIL
-Y4- +38.00 BEGIN HANDRAIL
-Y4- +35.00 END HANDRAIL

-Y4- +77.00 END HANDRAIL
-Y4- +67.63 END HANDRAIL
-Y4- +05.06 END MONO ISLD BEGIN C&G

END CONSTRUCTION
-Y9- STA. 11+00.00

-Y9- PT Sta. 11+80.94
RETAIN CREST -Y4- 45+32.04 Elevation: 691.98

FILL IN EXISTING JS EST. 172 CY SEE DETAIL SBX
STANDARD 'S' BASE DITCH w/CLASS 'B' RIP RAP SLOPE = 1:70% SEE DETAIL SBX

- NOTES:
1. ALL DRIVEWAY RADII ARE 20' UNLESS OTHERWISE NOTED
 2. FOR -Y4- & -Y9- INTERSECTION DETAILS, SEE SHEET 2B-14
 3. FOR -Y4- PROFILE, SEE SHEET 25
 4. FOR -Y9- PROFILE, SEE SHEET 28

5/14/99

PROJECT REFERENCE NO. U-5768	SHEET NO. 14
RW SHEET NO.	
ROADWAY DESIGN ENGINEER	HYDRAULICS ENGINEER
INCOMPLETE PLANS DO NOT USE FOR R/W ACQUISITION	
DOCUMENT NOT CONSIDERED FINAL UNLESS ALL SIGNATURES COMPLETED	

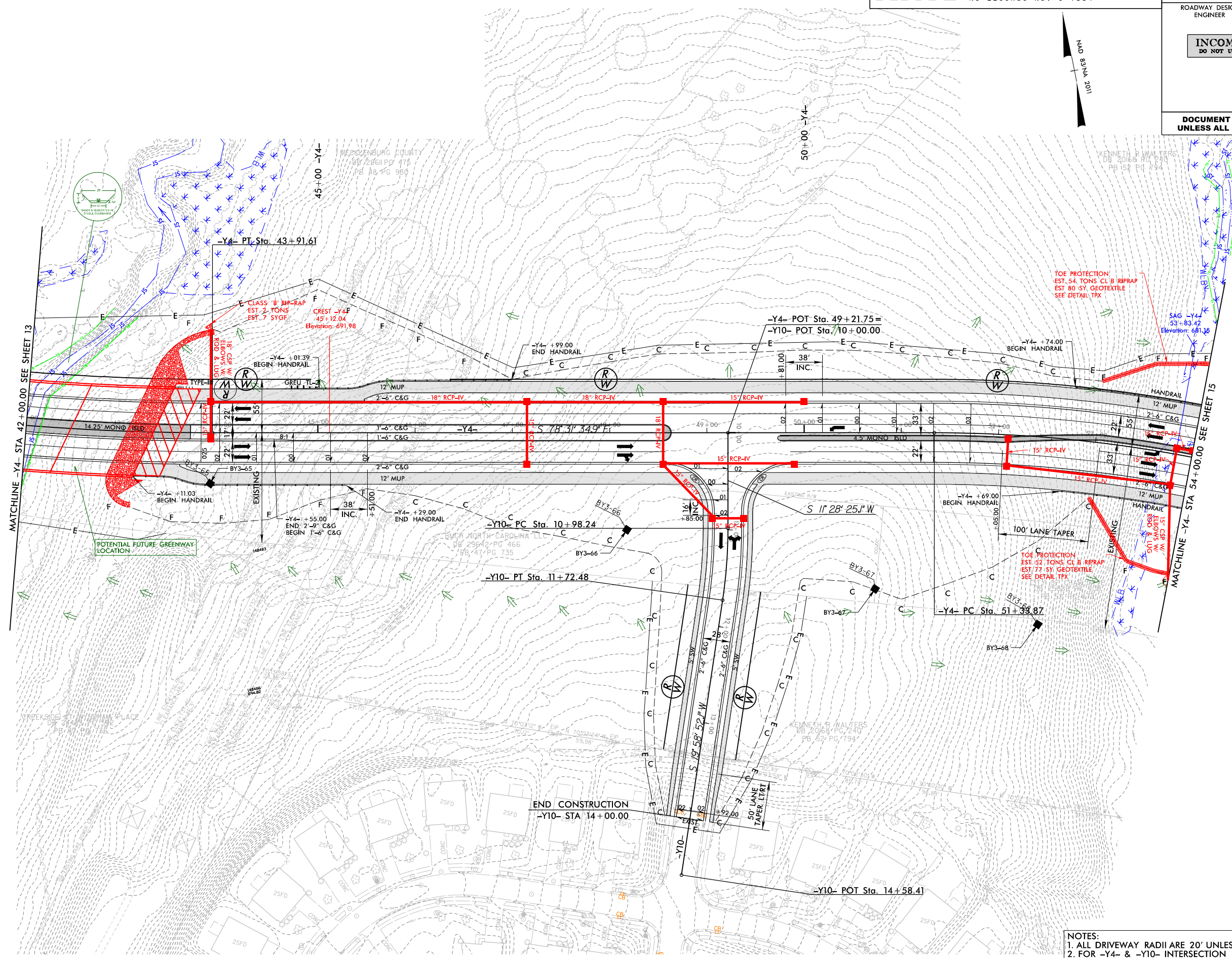

20-AUG-2019 09:57:57 68_HYD_PSH14.dgn
 20-AUG-2019 09:57:57 68_HYD_PSH14.dgn
 20-AUG-2019 09:57:57 68_HYD_PSH14.dgn

- NOTES:**
1. ALL DRIVEWAY RADII ARE 20' UNLESS OTHERWISE NOTED
 2. FOR -Y4- & -Y10- INTERSECTION DETAILS, SEE SHEET 25 & 26
 3. FOR -Y4- PROFILE, SEE SHEETS 25 & 26
 4. FOR -Y10- PROFILE, SEE SHEET 28

PROJECT REFERENCE NO.	SHEET NO.
U-5768	15
RW SHEET NO.	
ROADWAY DESIGN ENGINEER	HYDRAULICS ENGINEER
INCOMPLETE PLANS DO NOT USE FOR R/W ACQUISITION	
DOCUMENT NOT CONSIDERED FINAL UNLESS ALL SIGNATURES COMPLETED	

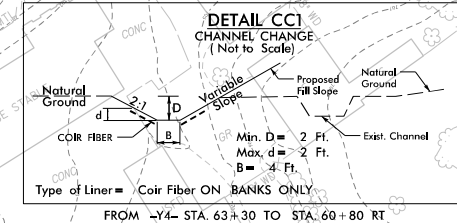
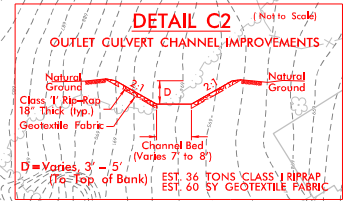
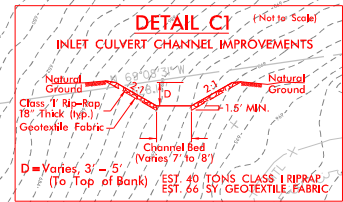
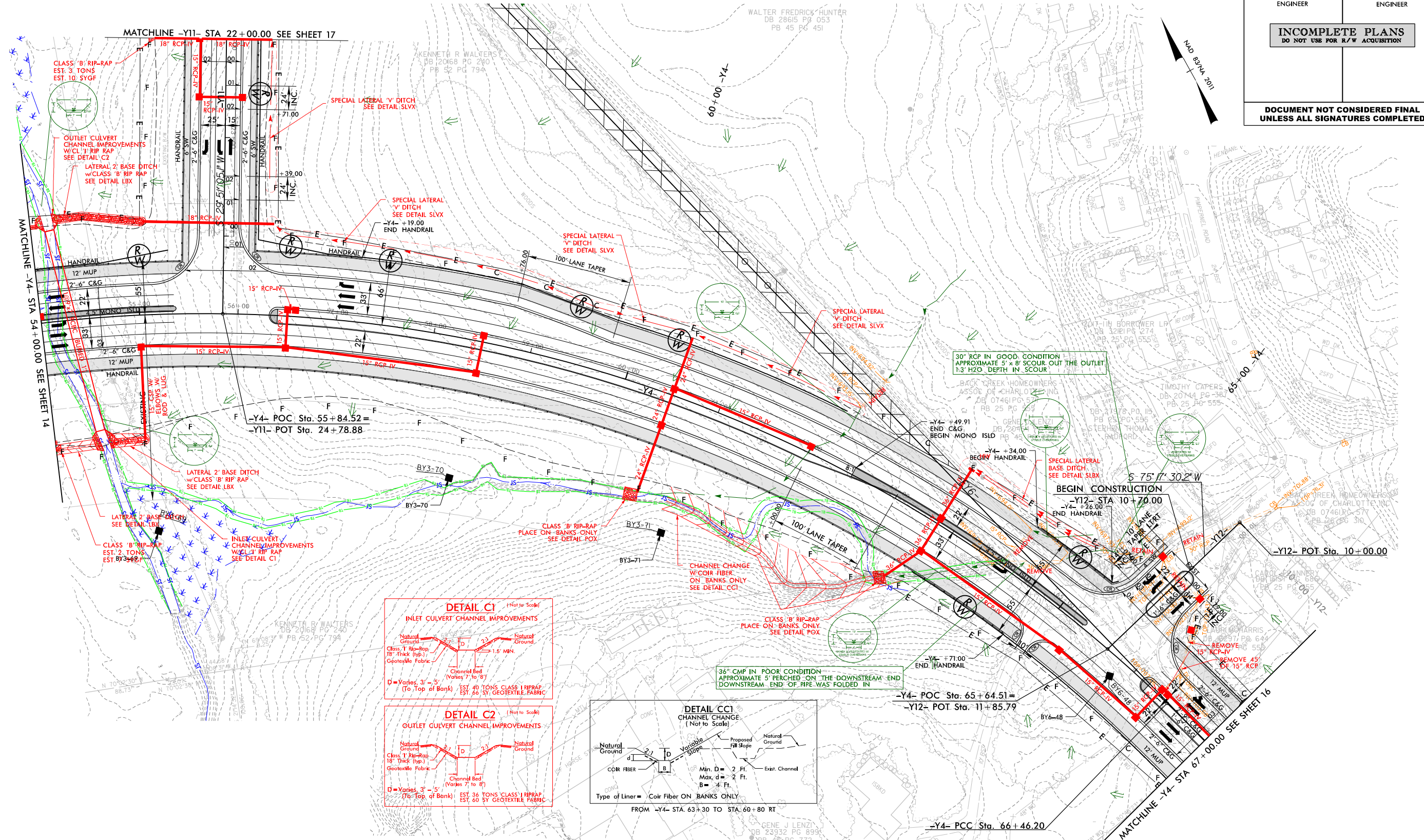

- NOTES:**
1. ALL DRIVEWAY RADII ARE 20' UNLESS OTHERWISE NOTED
 2. FOR -Y4- & -Y11- INTERSECTION DETAILS, SEE SHEET 2B-15
 3. FOR -Y4- & -Y12- INTERSECTION DETAILS, SEE SHEET 2B-16
 4. FOR -Y4- PROFILE, SEE SHEET 26
 5. FOR -Y11- PROFILE, SEE SHEET 29
 6. FOR -Y12- PROFILE, SEE SHEET 29

PROJECT REFERENCE NO. U-5768	SHEET NO. 16
RW SHEET NO.	
ROADWAY DESIGN ENGINEER	HYDRAULICS ENGINEER
INCOMPLETE PLANS DO NOT USE FOR R/W ACQUISITION	
DOCUMENT NOT CONSIDERED FINAL UNLESS ALL SIGNATURES COMPLETED	

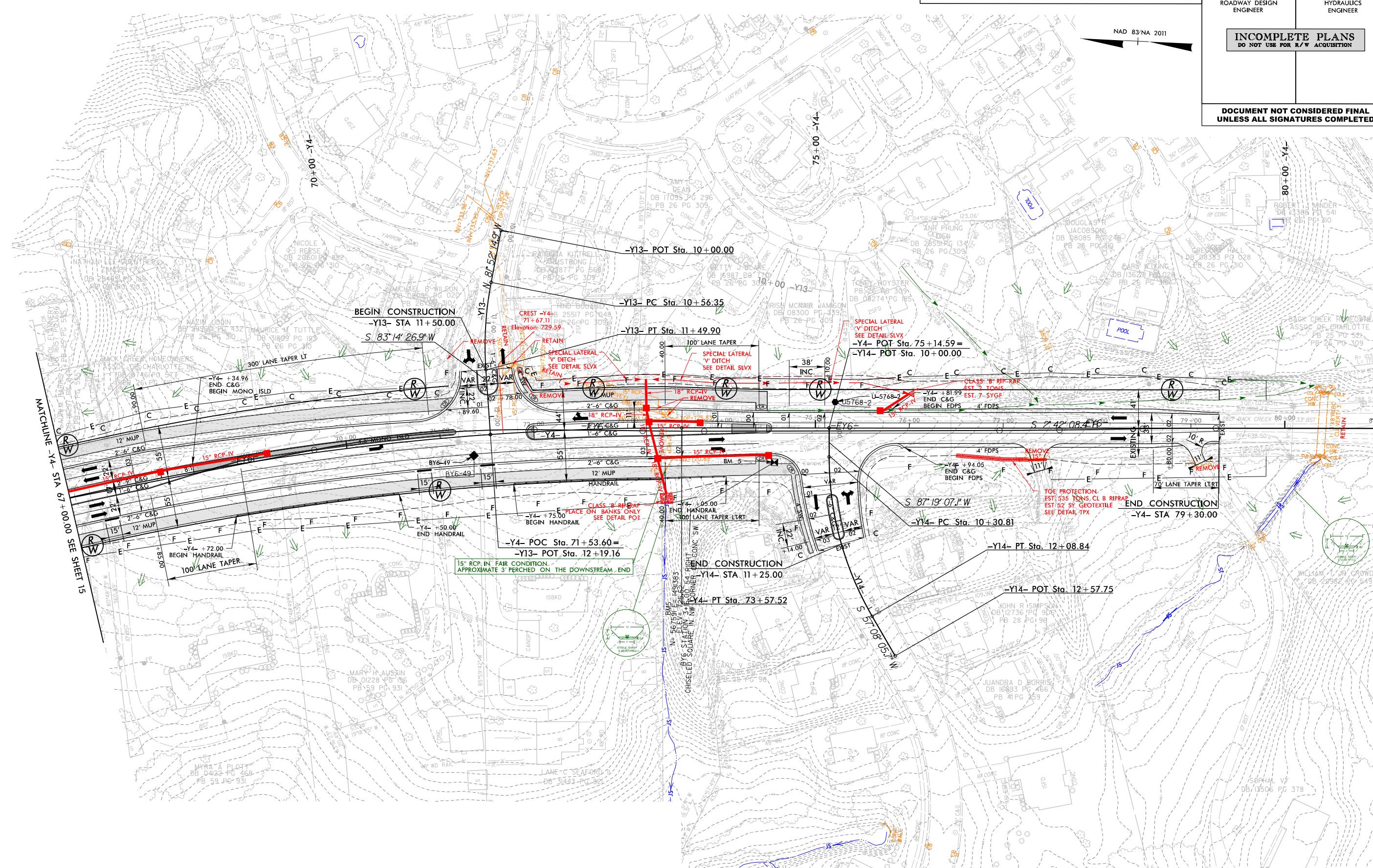
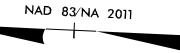

- NOTES:
1. ALL DRIVEWAY RADII ARE 20' UNLESS OTHERWISE NOTED
 2. FOR -Y4- & -Y13- INTERSECTION DETAILS, SEE SHEET 2B-16
 3. FOR -Y4- & -Y14- INTERSECTION DETAILS, SEE SHEET 2B-17
 4. FOR -Y4- PROFILE, SEE SHEETS 26 & 27
 5. FOR -Y13- PROFILE, SEE SHEET 30
 6. FOR -Y14- PROFILE, SEE SHEET 30

PROJECT REFERENCE NO.	SHEET NO.
U-5768	17
RW SHEET NO.	
ROADWAY DESIGN ENGINEER	HYDRAULICS ENGINEER
INCOMPLETE PLANS DO NOT USE FOR R/W ACQUISITION	
DOCUMENT NOT CONSIDERED FINAL UNLESS ALL SIGNATURES COMPLETED	

INSET

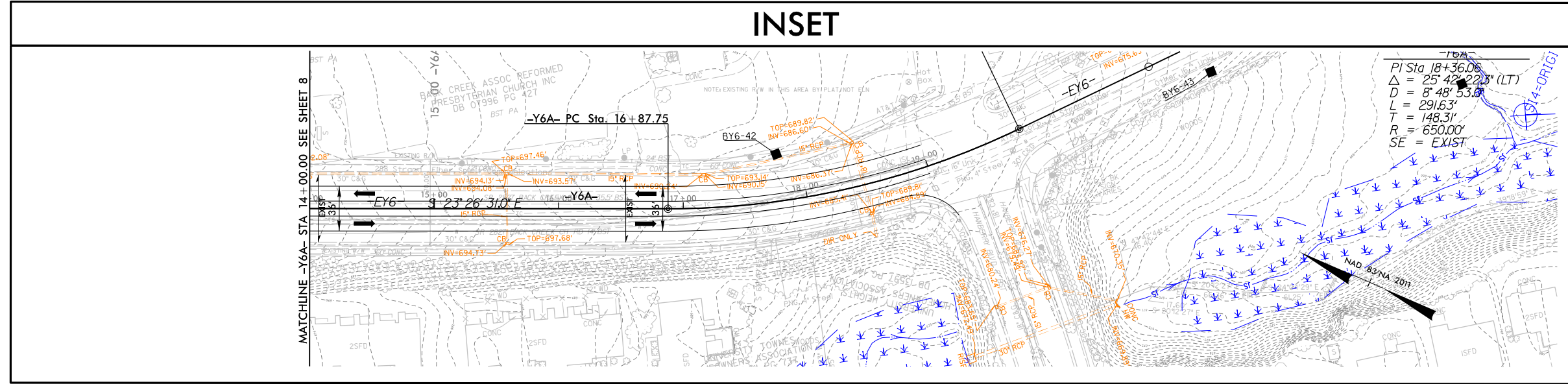

NO JURISDICTIONAL RESOURCES IMPACTED ON THIS PAGE.

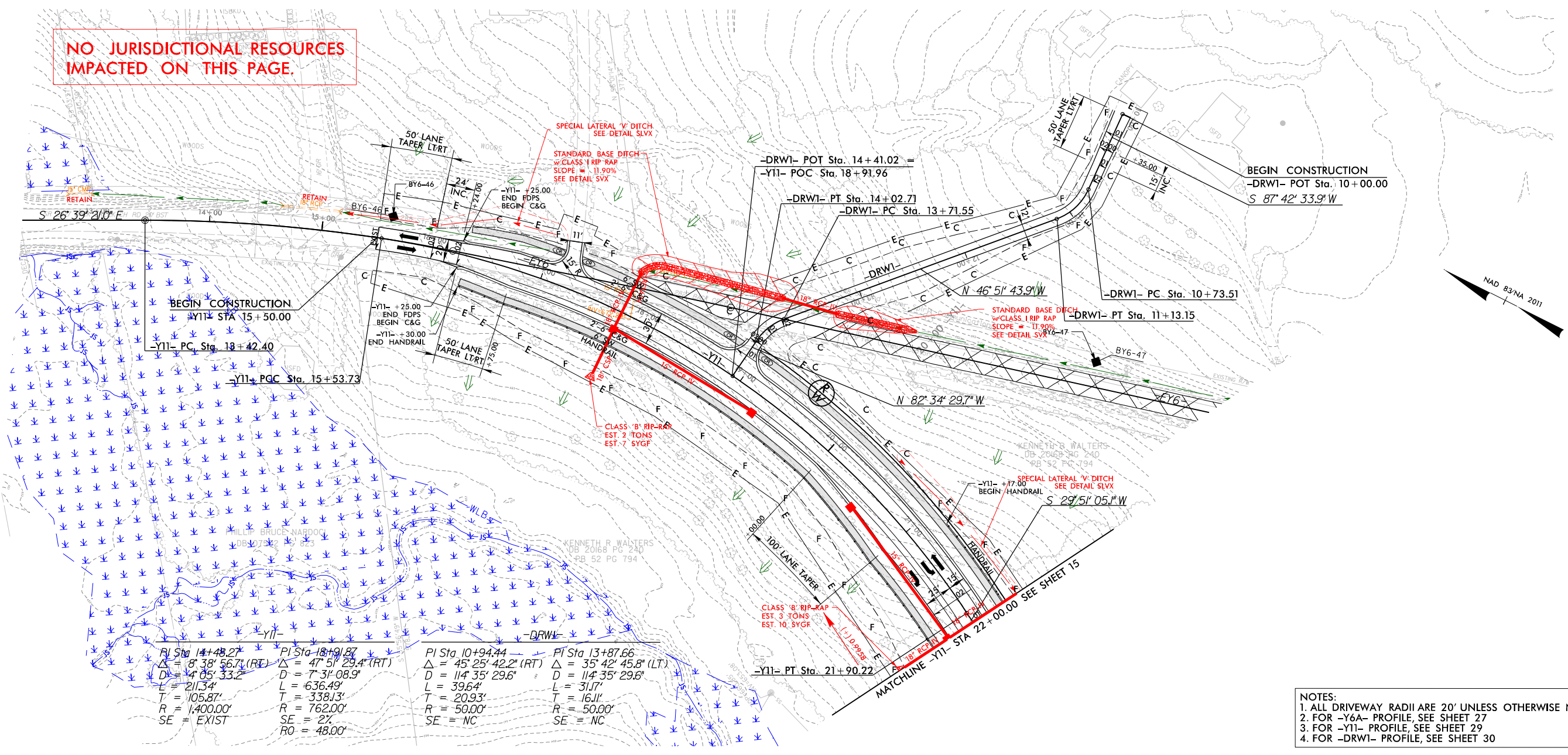

PI Sta 14+48.27 Δ = 8° 38' 56.7" (RT) D = 14' 05' 33.2" L = 211.34' T = 105.87' R = 1,400.00' SE = EXIST	PI Sta 18+19.87 Δ = 47° 51' 29.4" (RT) D = 7' 31' 08.9" L = 636.49' T = 338.13' R = 762.00' SE = 2% RO = 48.00'	PI Sta 10+94.44 Δ = 45° 25' 42.2" (RT) D = 114' 35' 29.6" L = 39.64' T = 20.93' R = 50.00' SE = NC	PI Sta 13+87.66 Δ = 35° 42' 45.8" (LT) D = 114' 35' 29.6" L = 31.7' T = 16.11' R = 50.00' SE = NC
--	--	--	---

- NOTES:
 1. ALL DRIVEWAY RADII ARE 20' UNLESS OTHERWISE NOTED
 2. FOR -Y6A- PROFILE, SEE SHEET 27
 3. FOR -Y11- PROFILE, SEE SHEET 29
 4. FOR -DRW1- PROFILE, SEE SHEET 30

5/14/99
 30-AUC-20R19568-HYD_PSH17.dgn

INCOMPLETE PLANS
 DO NOT USE FOR R/W ACQUISITION

DOCUMENT NOT CONSIDERED FINAL
 UNLESS ALL SIGNATURES COMPLETED

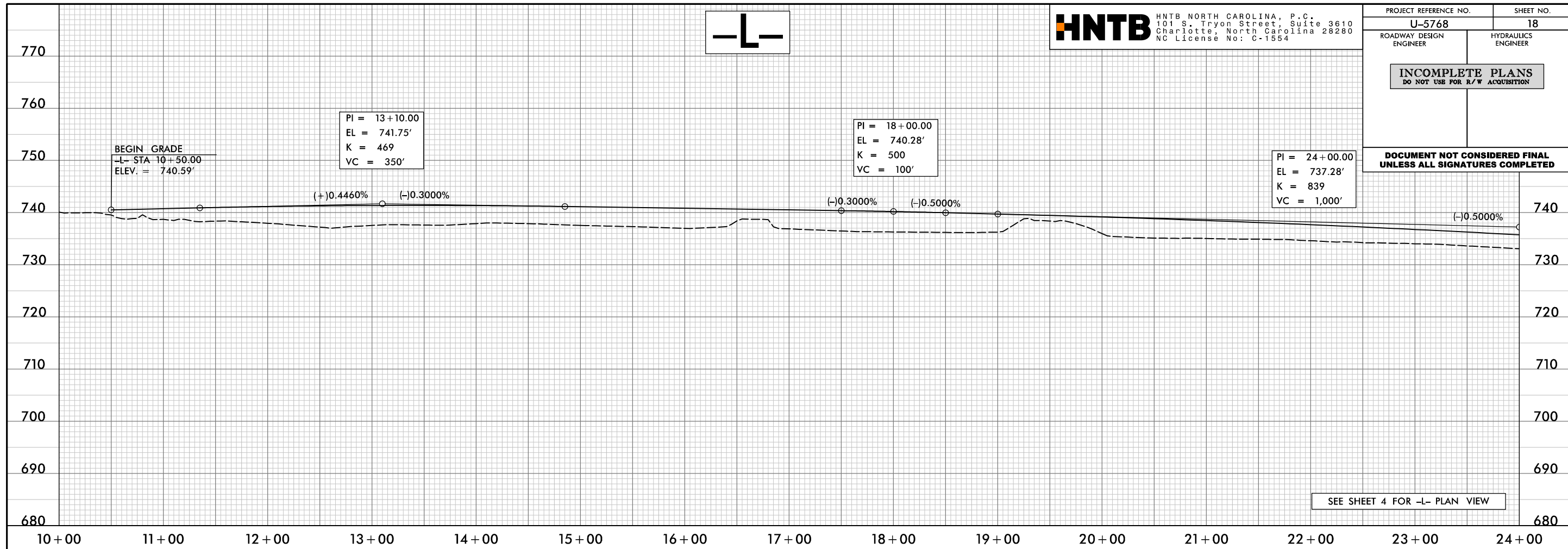

SEE SHEET 4 FOR -L- PLAN VIEW

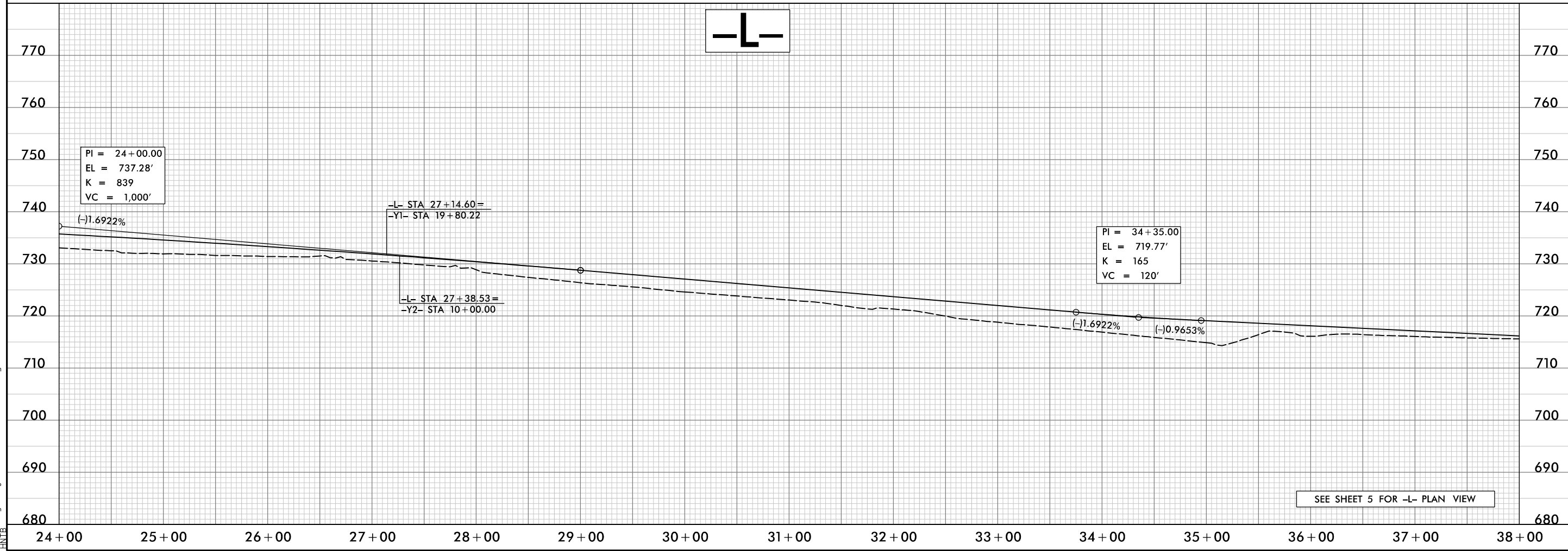

SEE SHEET 5 FOR -L- PLAN VIEW

**DOCUMENT NOT CONSIDERED FINAL
 UNLESS ALL SIGNATURES COMPLETED**

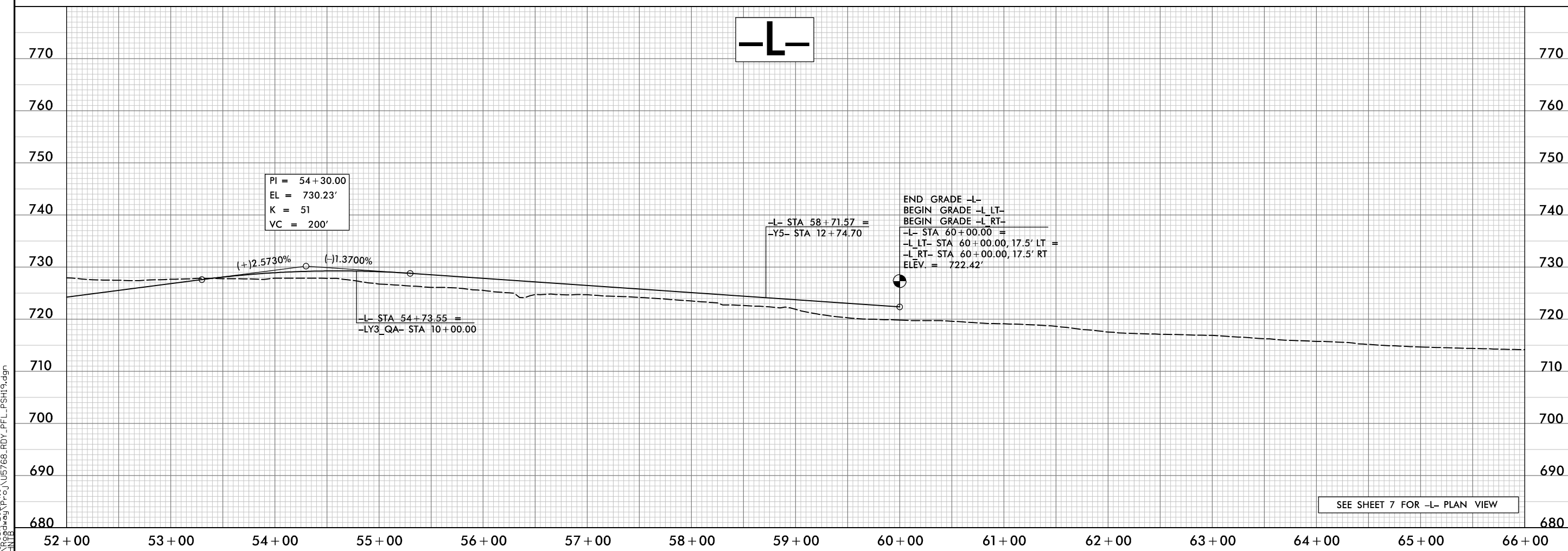
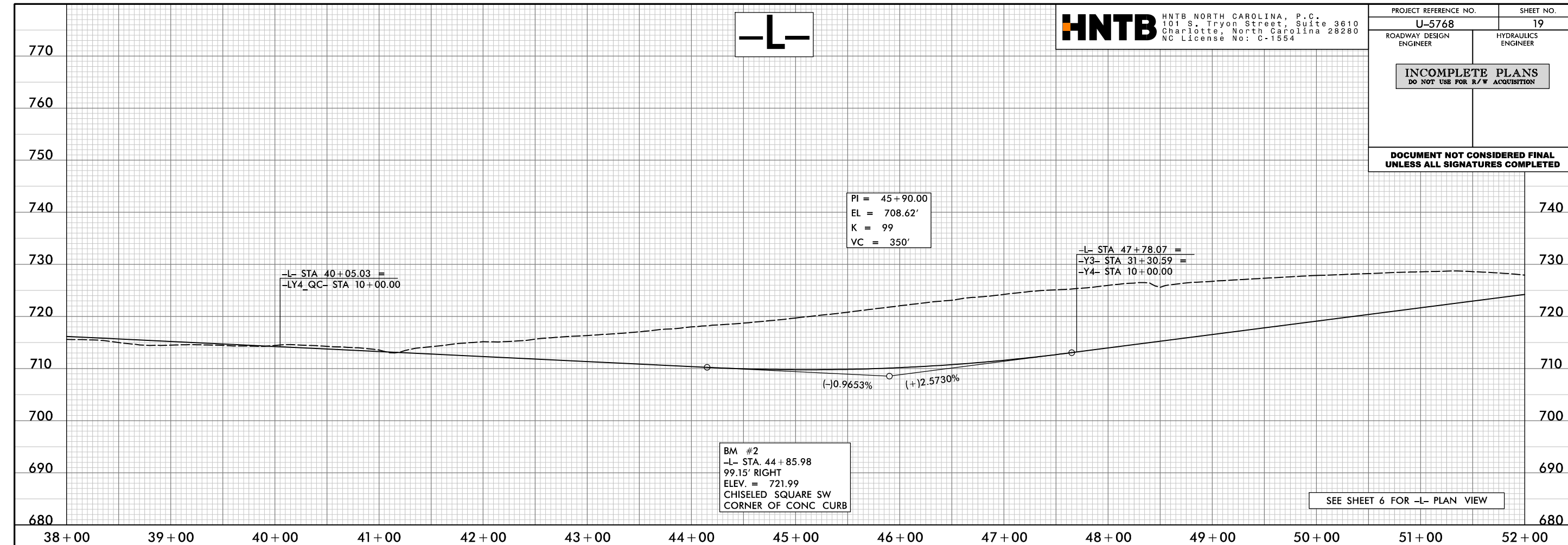

I:\JUN-2021\4404
 Roadway\Project\U5768_RDY_PFL_PSH19.dgn
 HNTB

5/28/99

-L_LT-

HNTB HNTB NORTH CAROLINA, P.C.
101 S. Tryon Street, Suite 3610
Charlotte, North Carolina 28280
NC License No: C-1554

PROJECT REFERENCE NO.	SHEET NO.
U-5768	20
ROADWAY DESIGN ENGINEER	HYDRAULICS ENGINEER
INCOMPLETE PLANS DO NOT USE FOR R/W ACQUISITION	
DOCUMENT NOT CONSIDERED FINAL UNLESS ALL SIGNATURES COMPLETED	

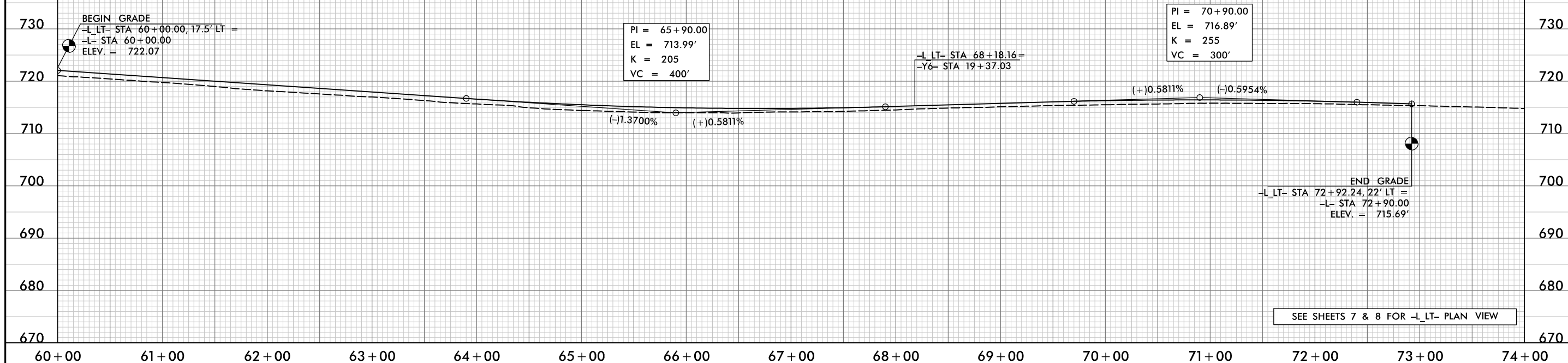

-L_RT-

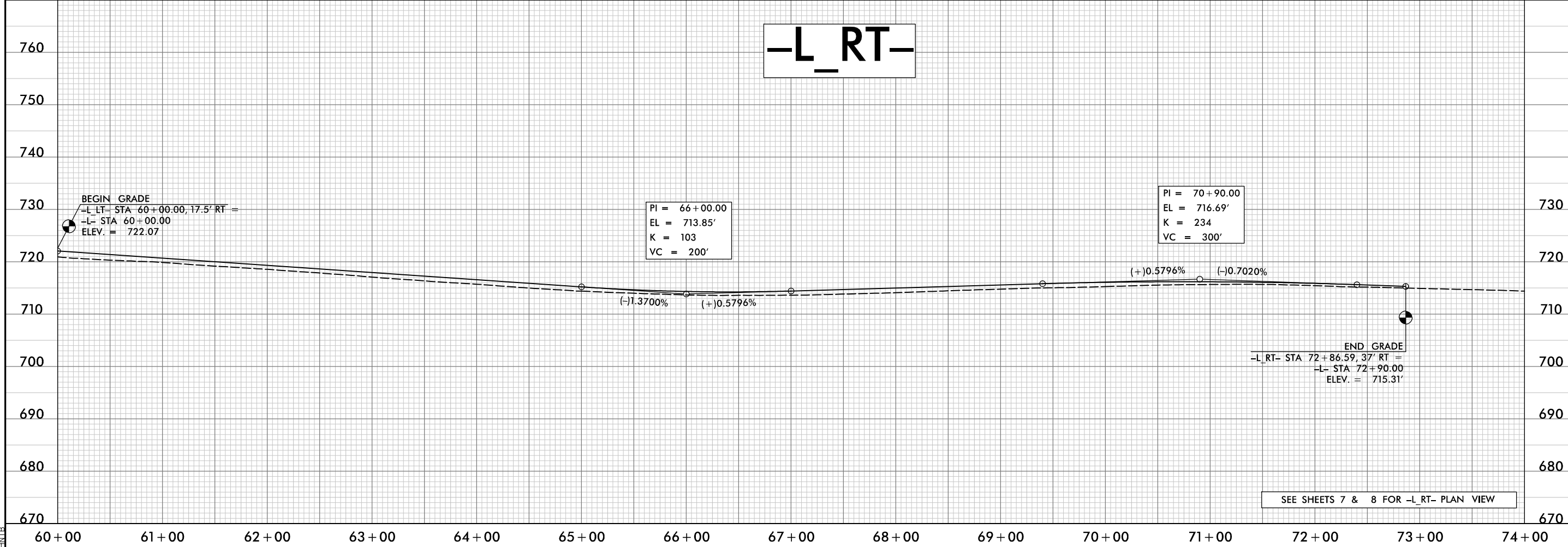

\\j\j\2021\404\Roadway\Project\U5768_RDY_PFL_PS\H20.dgn

5/28/99

-LY3_QA-

HNTB HNTB NORTH CAROLINA, P.C.
 101 S. Tryon Street, Suite 3610
 Charlotte, North Carolina 28280
 NC License No: C-1554

PROJECT REFERENCE NO.	SHEET NO.
U-5768	21
ROADWAY DESIGN ENGINEER	HYDRAULICS ENGINEER
INCOMPLETE PLANS DO NOT USE FOR R/W ACQUISITION	
DOCUMENT NOT CONSIDERED FINAL UNLESS ALL SIGNATURES COMPLETED	

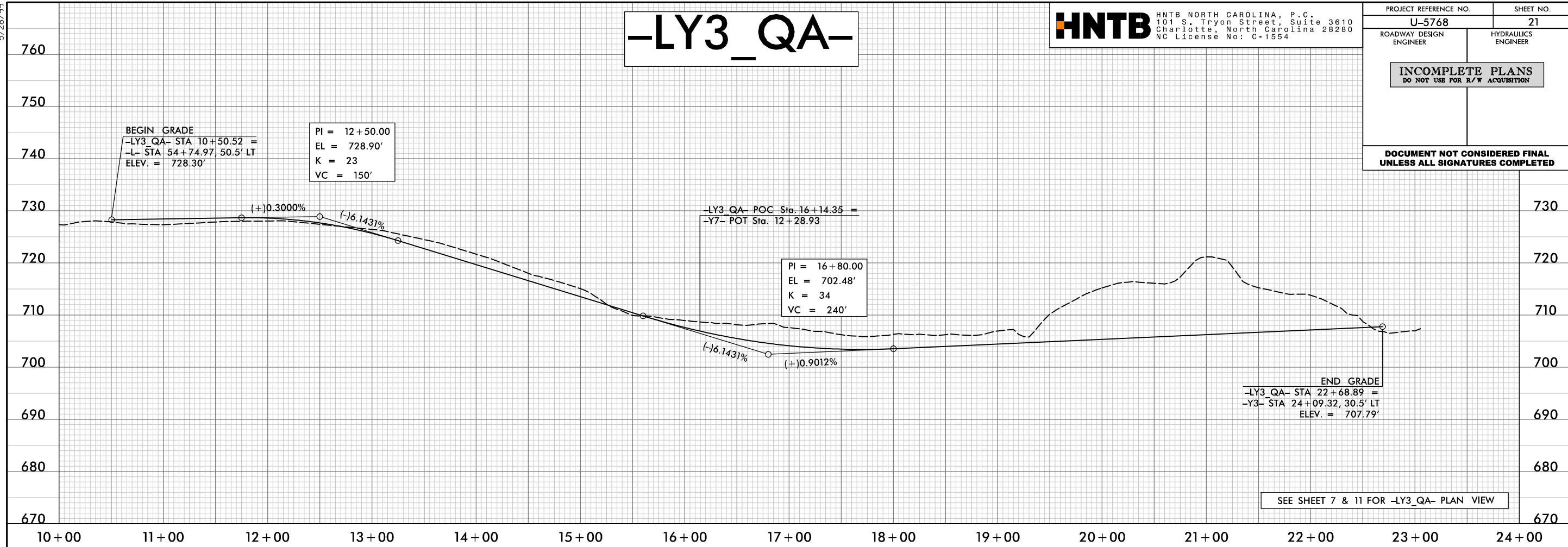

-LY4_QC-

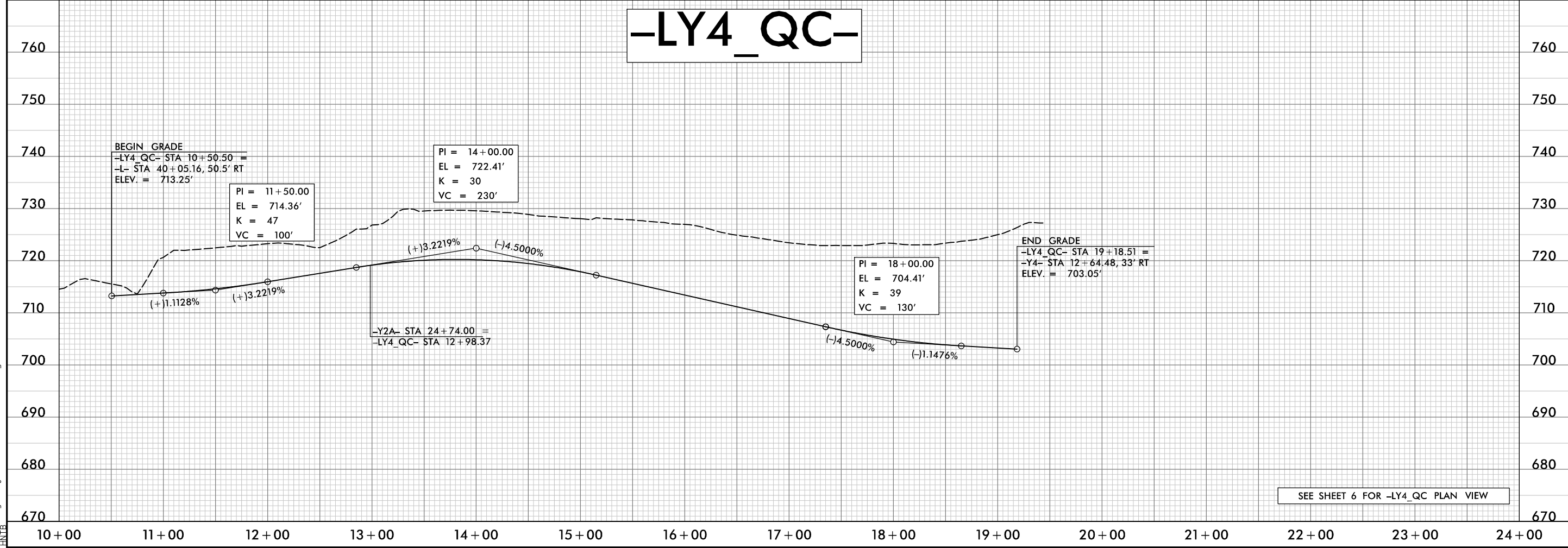

R:\JUN-2021\4404
Roadway\Project\U5768_RDY_PFL_PSH21.dgn
HNTB

5/28/99

-Y1-

HNTB HNTB NORTH CAROLINA, P.C.
 101 S. Tryon Street, Suite 3610
 Charlotte, North Carolina 28280
 NC License No: C-1554

PROJECT REFERENCE NO.	SHEET NO.
U-5768	22
ROADWAY DESIGN ENGINEER	HYDRAULICS ENGINEER
INCOMPLETE PLANS DO NOT USE FOR R/W ACQUISITION	
DOCUMENT NOT CONSIDERED FINAL UNLESS ALL SIGNATURES COMPLETED	

-Y1A-

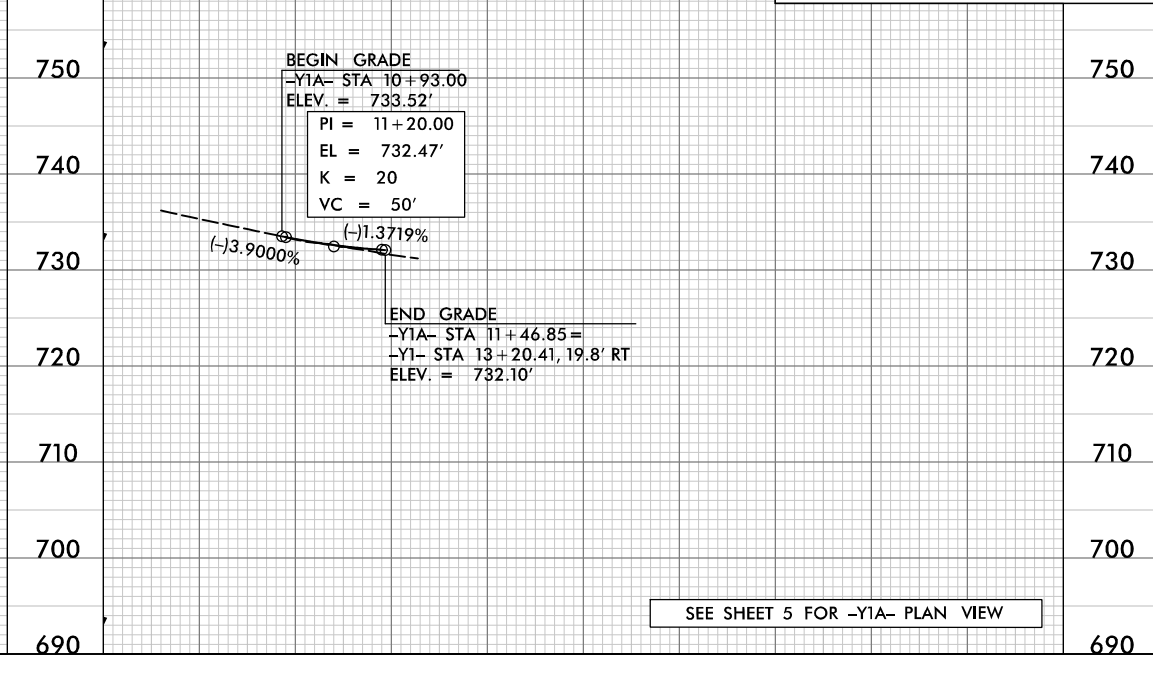
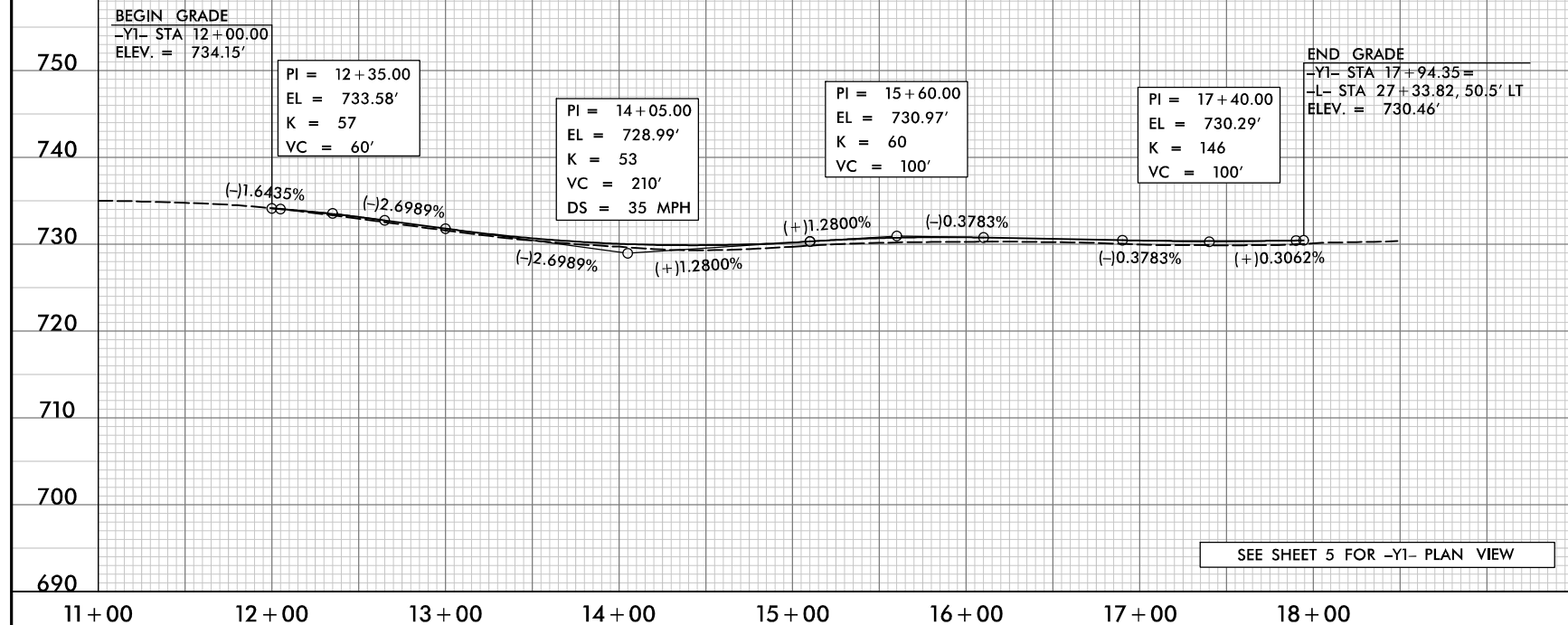

-Y2-

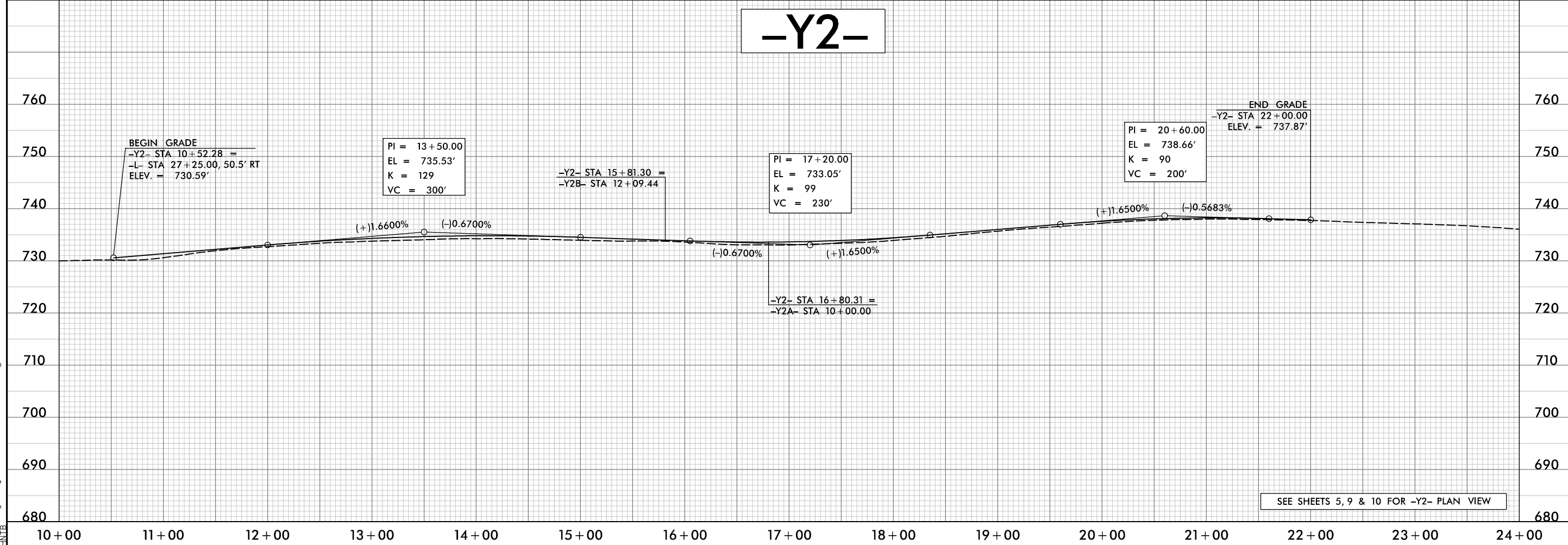

R:\JUN-2001\4404\Roadway\pco\U5768_RDY_PFL_PSH22.dgn

5/28/99

-Y2A-

HNTB HNTB NORTH CAROLINA, P.C.
 101 S. Tryon Street, Suite 3610
 Charlotte, North Carolina 28280
 NC License No: C-1554

PROJECT REFERENCE NO.	SHEET NO.
U-5768	23
ROADWAY DESIGN ENGINEER	HYDRAULICS ENGINEER
INCOMPLETE PLANS DO NOT USE FOR R/W ACQUISITION	
DOCUMENT NOT CONSIDERED FINAL UNLESS ALL SIGNATURES COMPLETED	

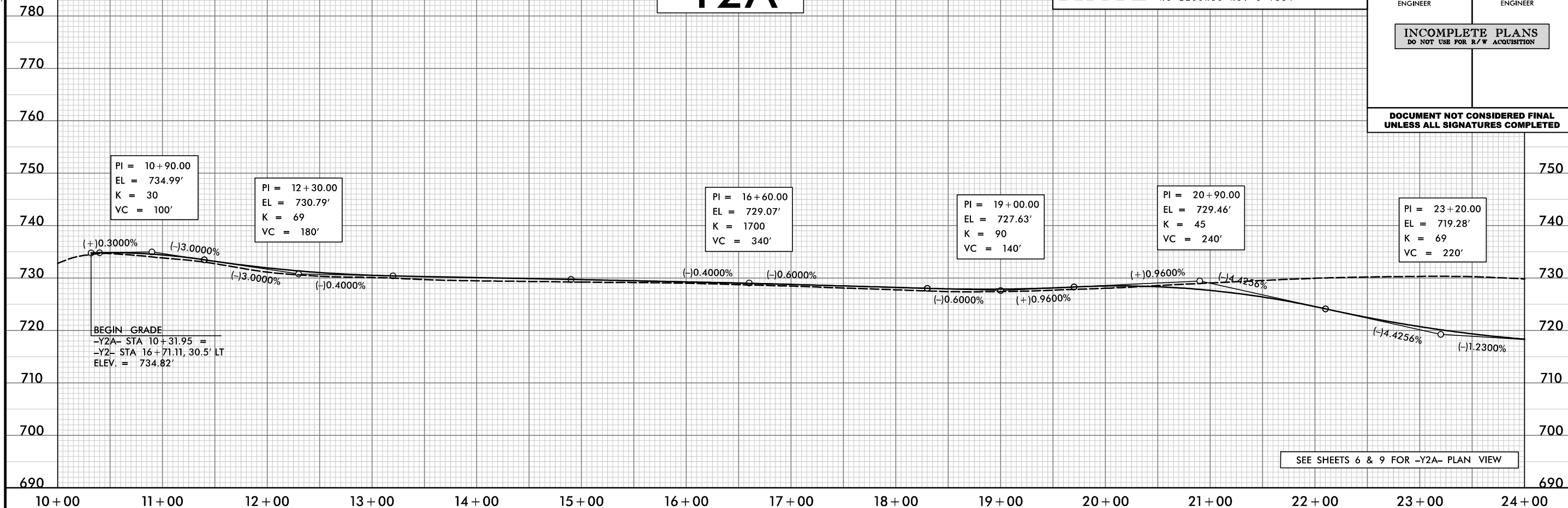

-Y2A-

-Y2B-

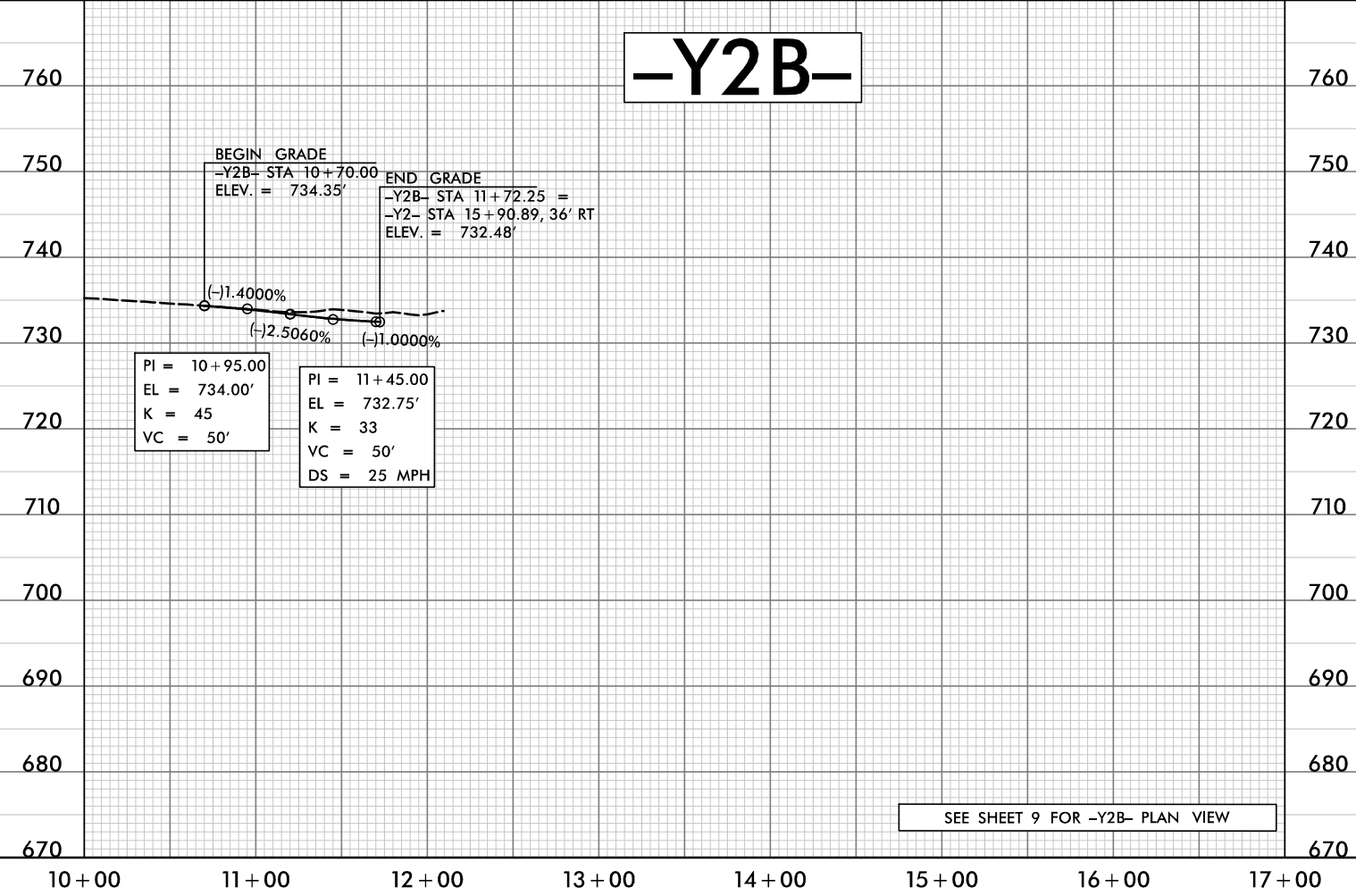
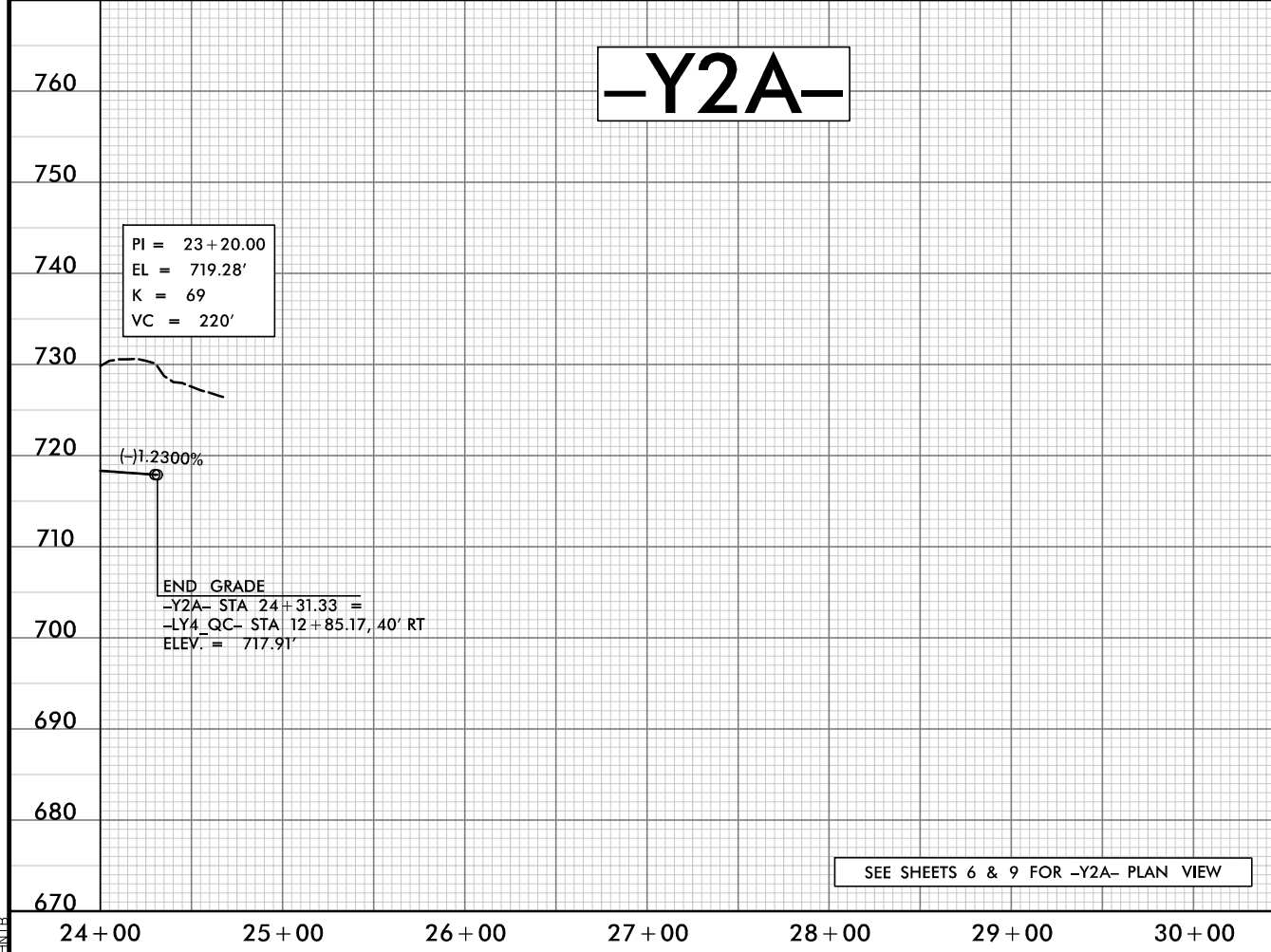

R:\JUN-2021\4404\Roadway\Project\U5768_RDY_PFL_PSH23.dgn

5/28/99

PROJECT REFERENCE NO.	SHEET NO.
U-5768	24
ROADWAY DESIGN ENGINEER	HYDRAULICS ENGINEER
INCOMPLETE PLANS DO NOT USE FOR R/W ACQUISITION	
DOCUMENT NOT CONSIDERED FINAL UNLESS ALL SIGNATURES COMPLETED	

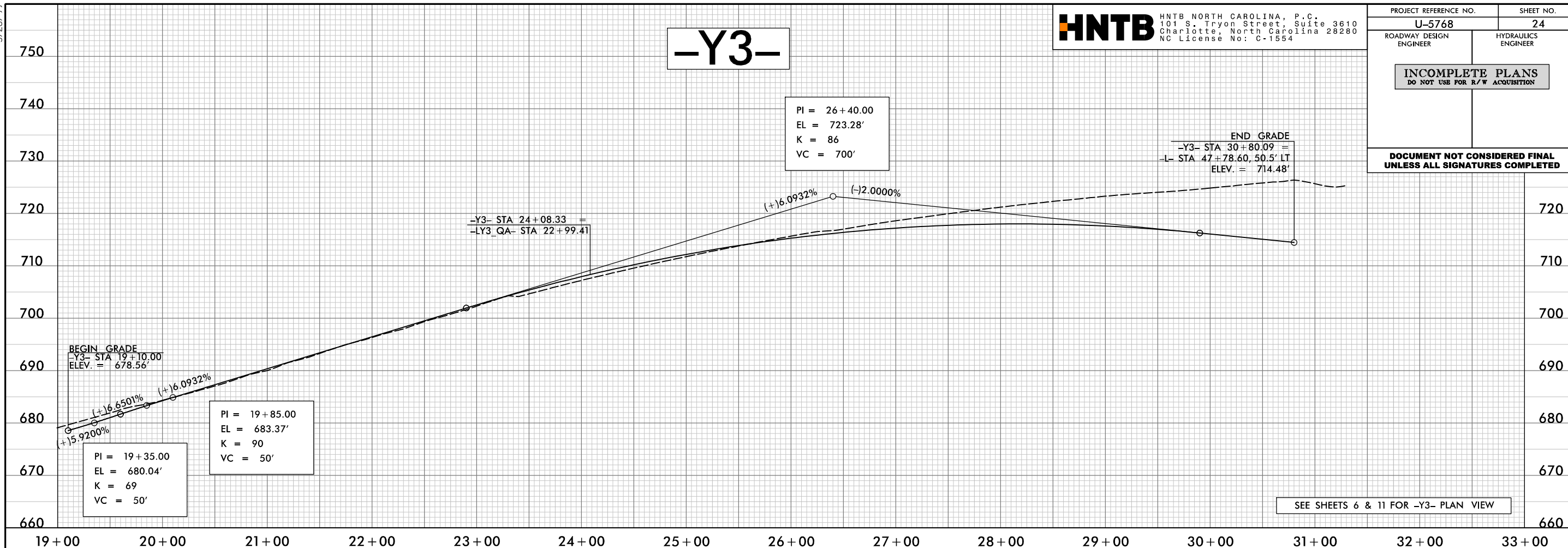

18 JUN 2021 14:04
V:\Roadway\Projects\U5768_RDY_PFL_PSH24.dgn

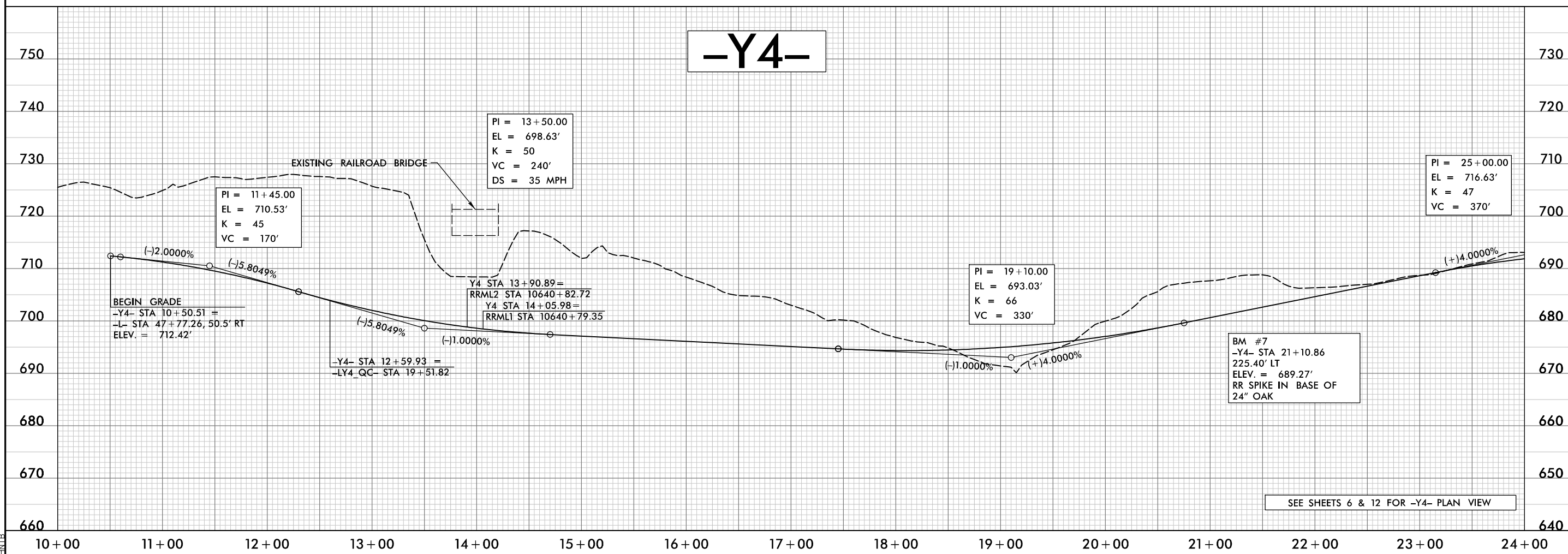

5/28/99

PROJECT REFERENCE NO. U-5768	SHEET NO. 25
ROADWAY DESIGN ENGINEER	HYDRAULICS ENGINEER
INCOMPLETE PLANS DO NOT USE FOR R/W ACQUISITION	
DOCUMENT NOT CONSIDERED FINAL UNLESS ALL SIGNATURES COMPLETED	

-Y4-

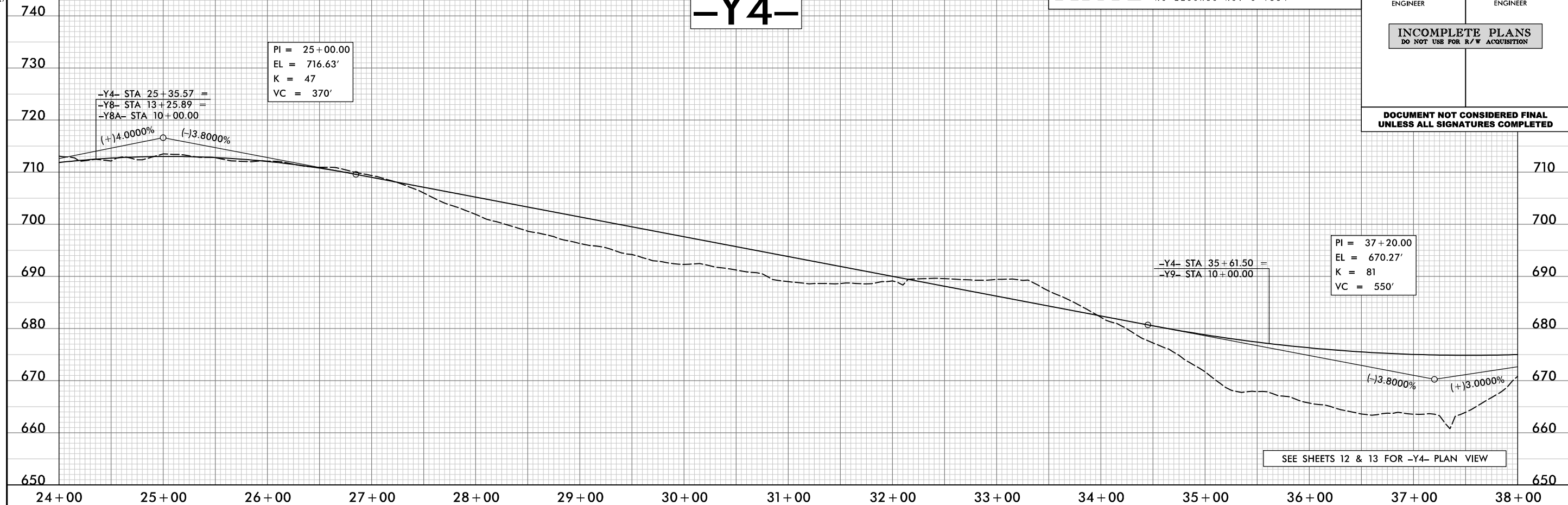

-Y4-

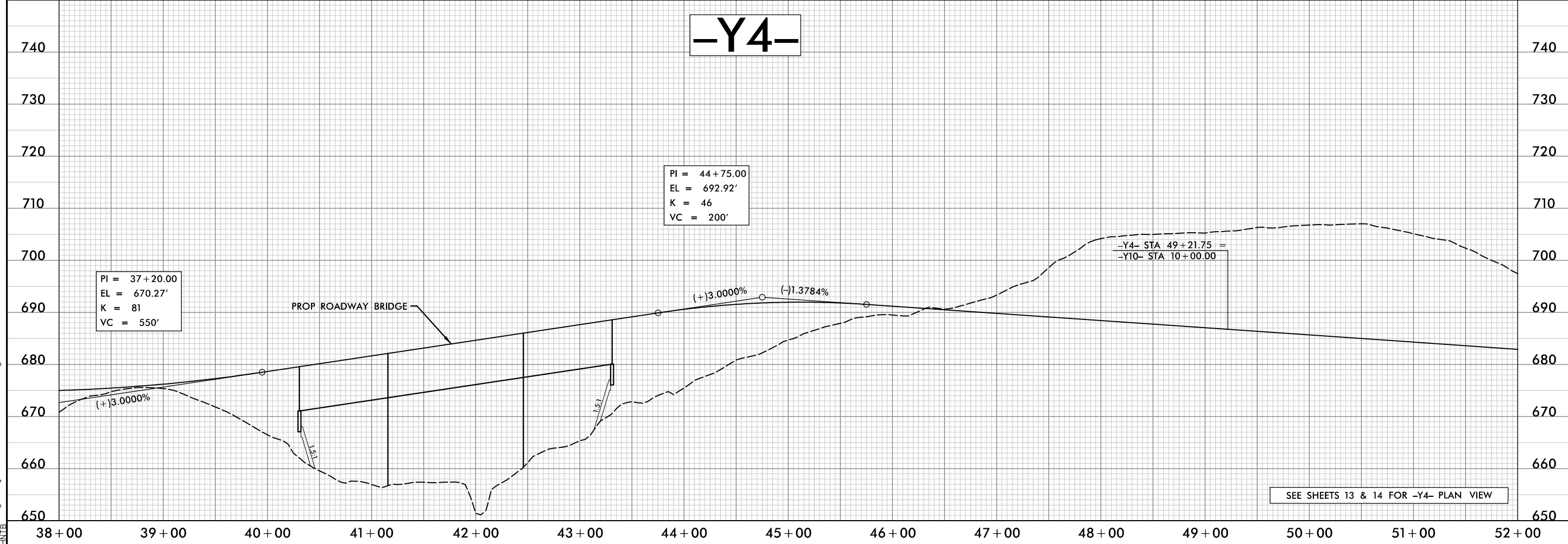

I:\JUN-2021\4404\Roadway\Proc\U5768_RDY_PFL_PSH25.dgn

5/28/99

**DOCUMENT NOT CONSIDERED FINAL
UNLESS ALL SIGNATURES COMPLETED**

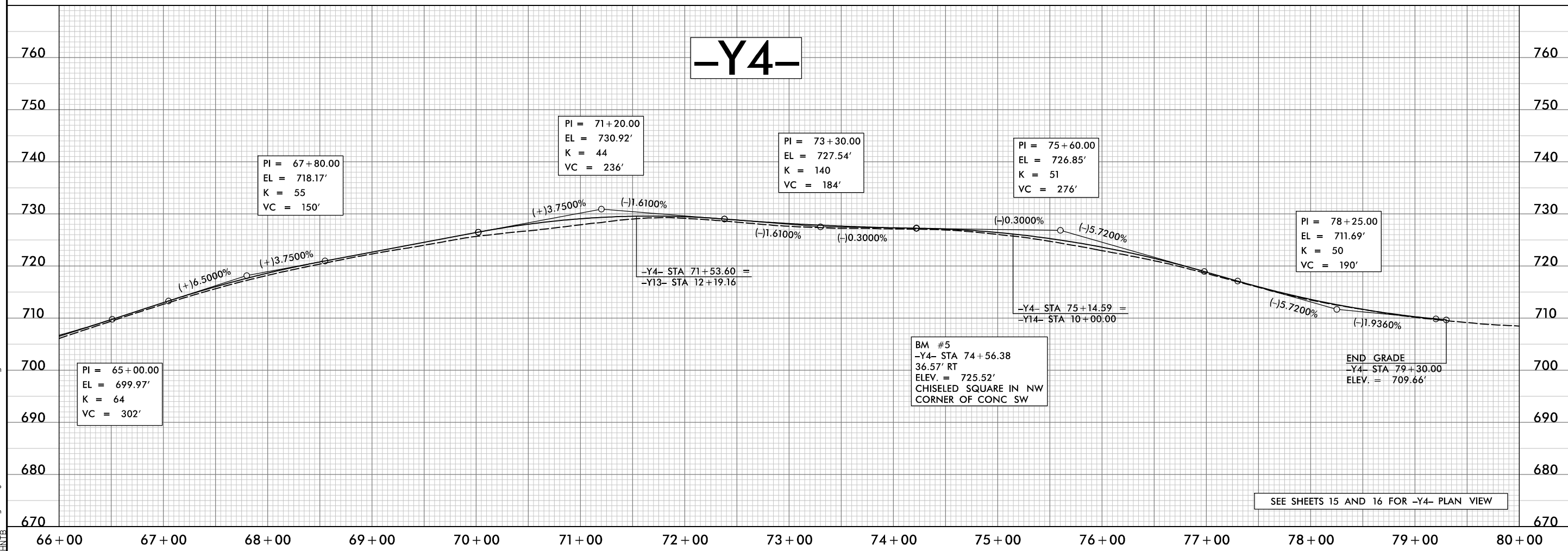
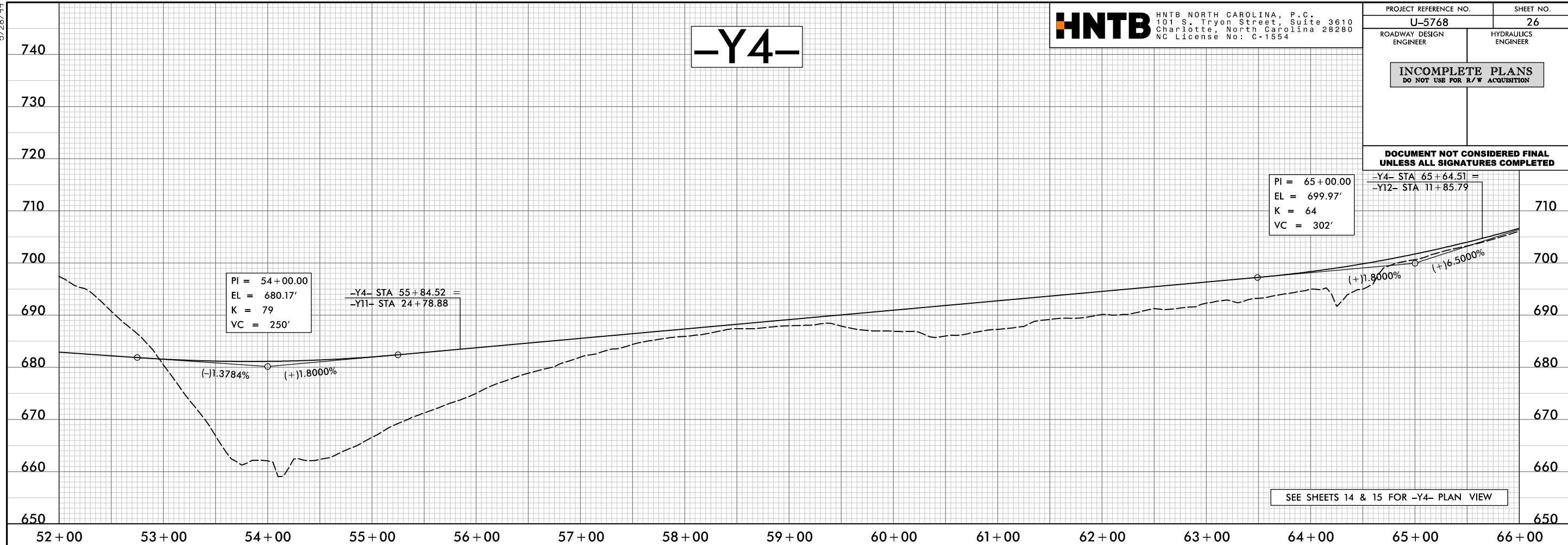

I:\JUN-2021\4404
 Roadway\Project\U5768_RDY_PFL_PS+26.dgn
 HNTB

5/28/99

PROJECT REFERENCE NO. U-5768	SHEET NO. 27
ROADWAY DESIGN ENGINEER	HYDRAULICS ENGINEER
INCOMPLETE PLANS DO NOT USE FOR R/W ACQUISITION	
DOCUMENT NOT CONSIDERED FINAL UNLESS ALL SIGNATURES COMPLETED	

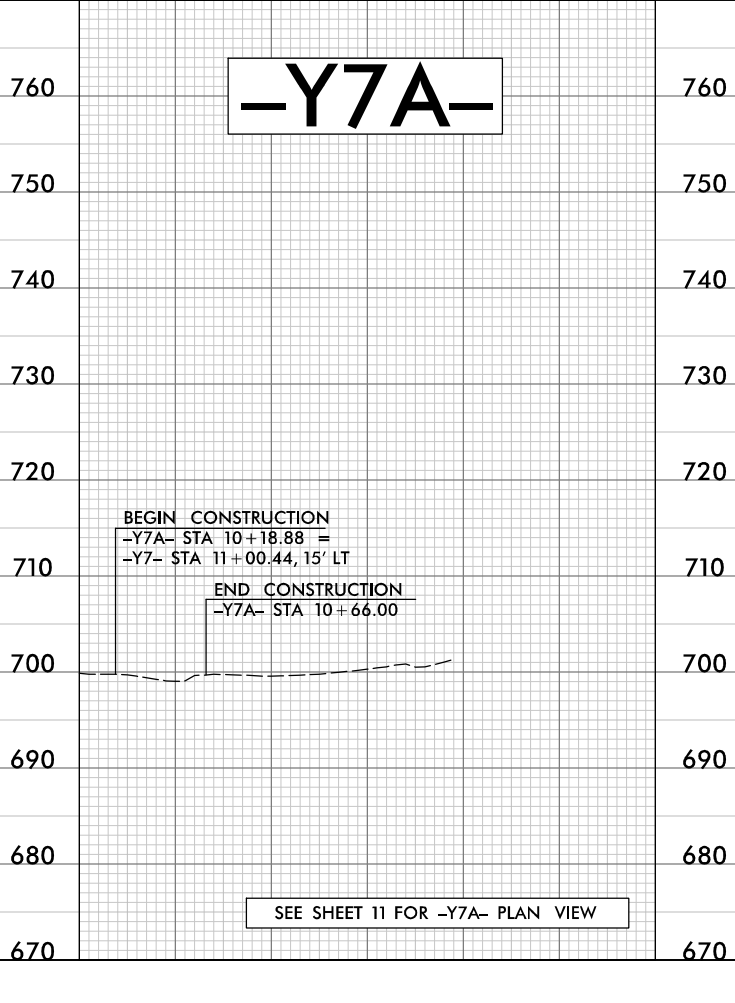
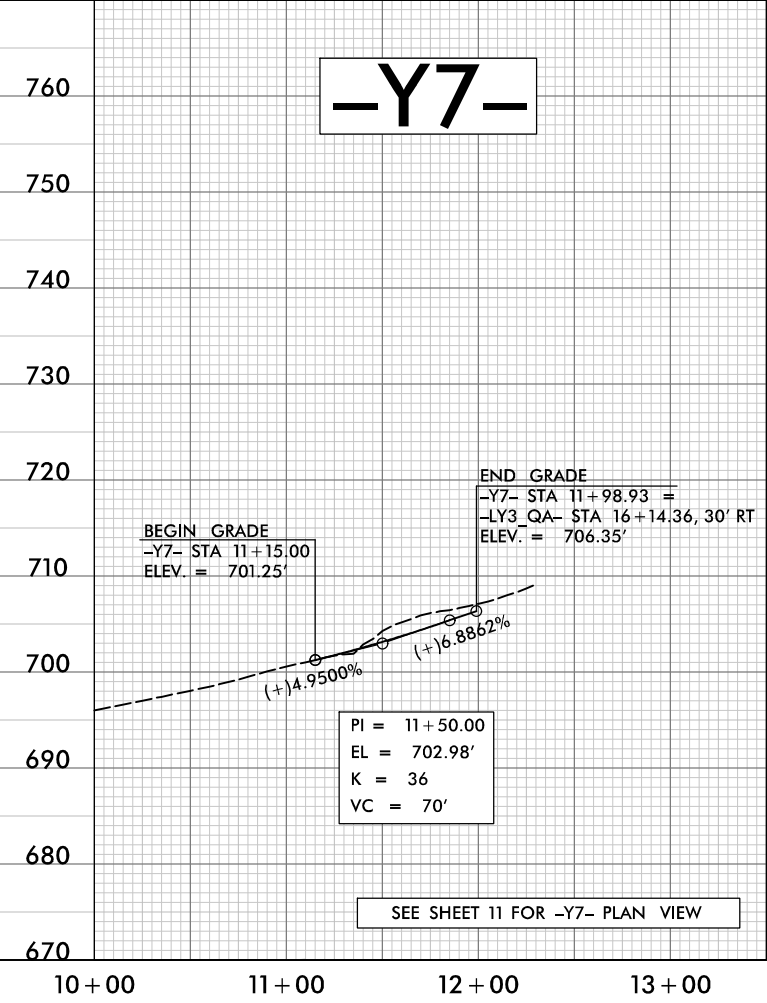
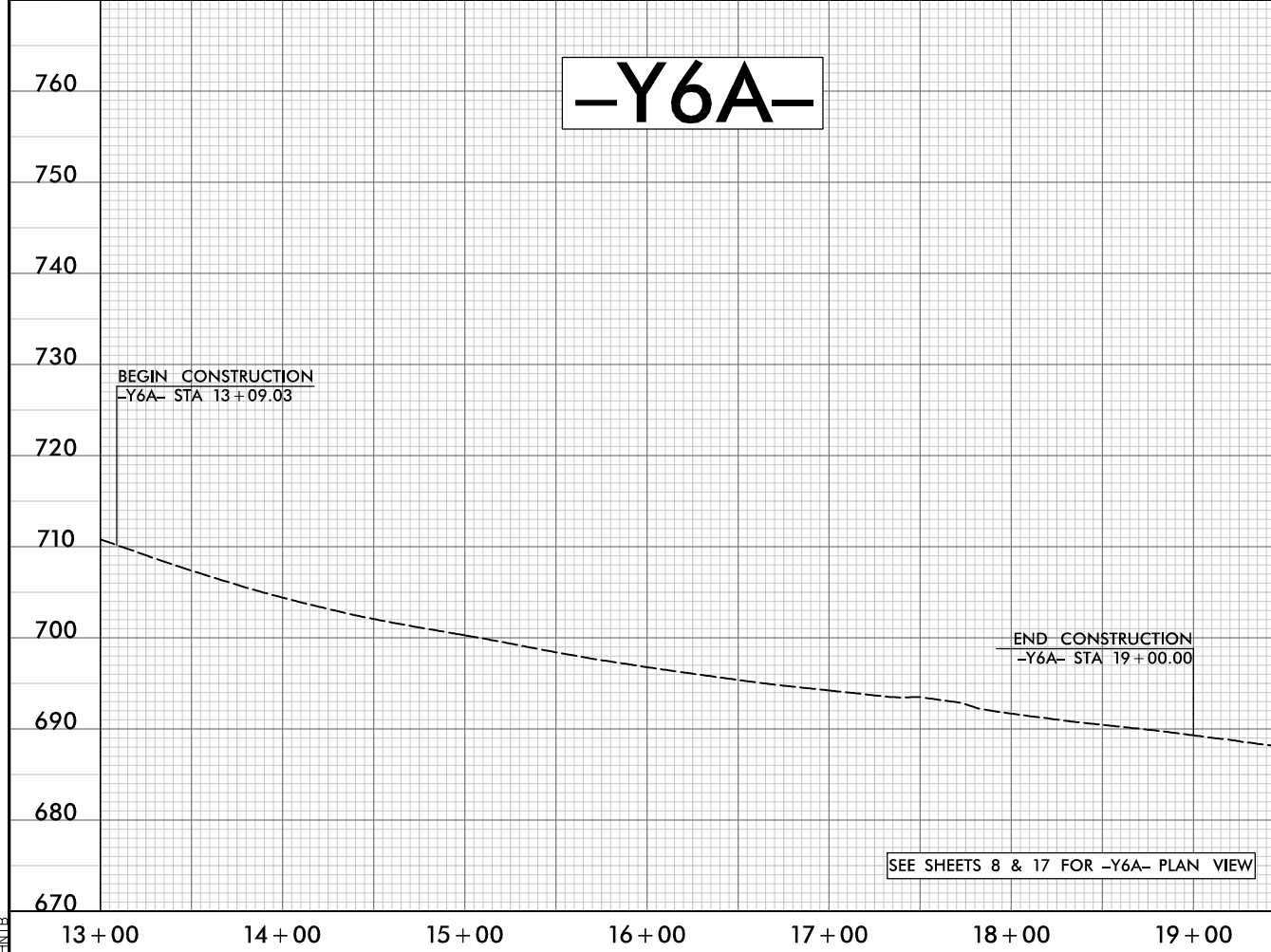
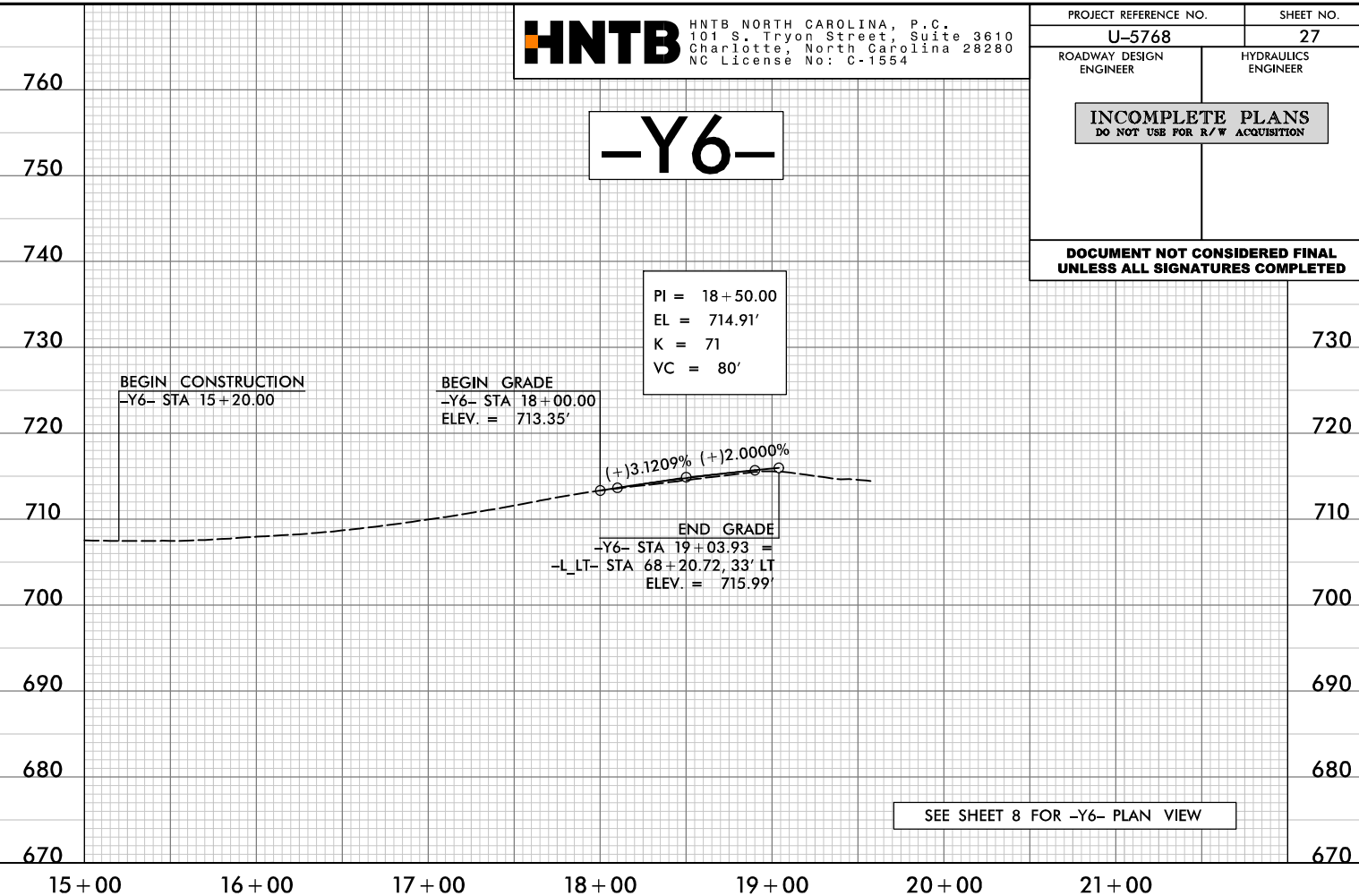
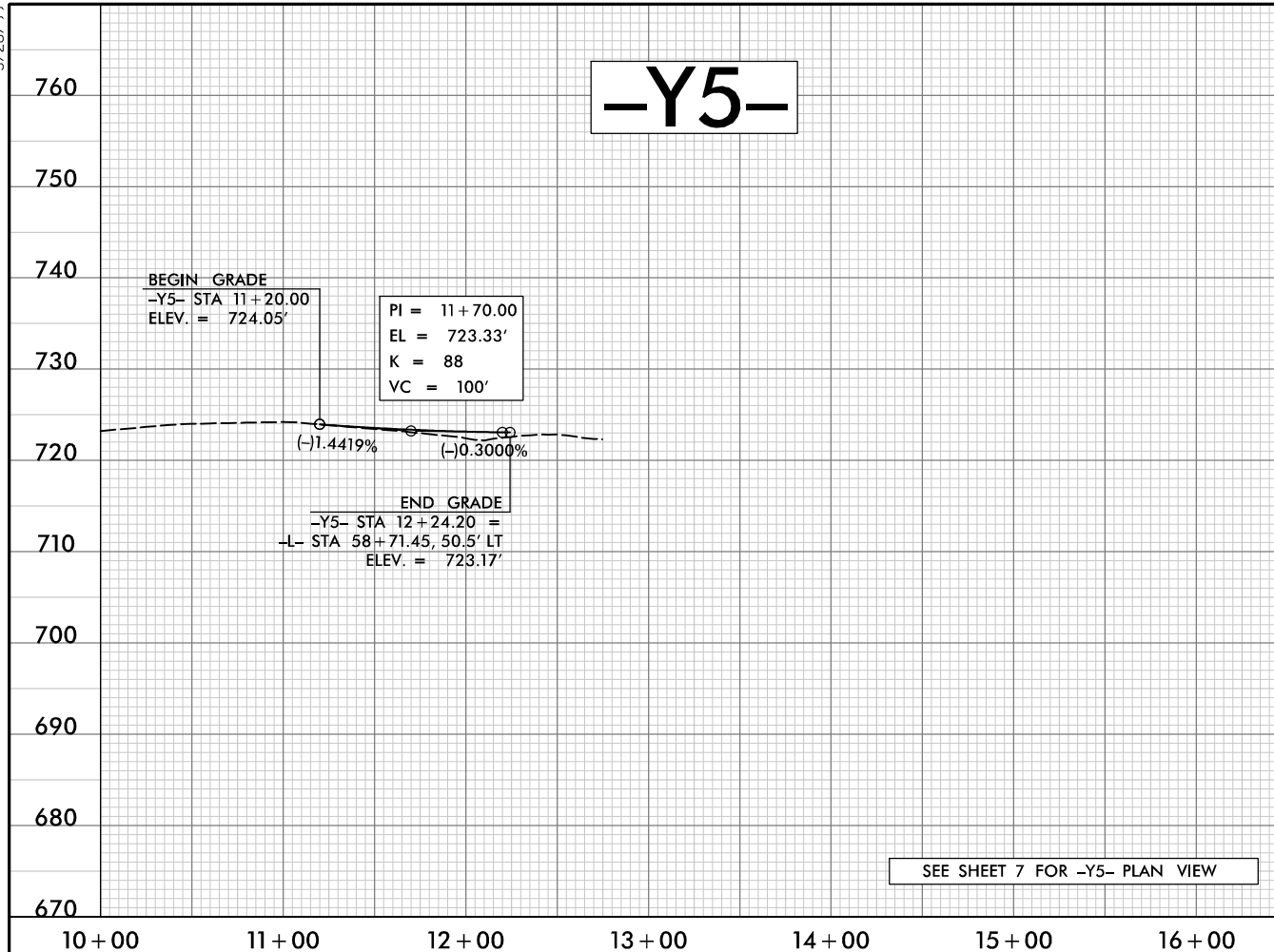

09-JUL-2002 09:44
V:\Roadway\99\05768_RDY_PFL_PSH27.dgn
HNTB

5/28/99

PROJECT REFERENCE NO.	SHEET NO.
U-5768	28
ROADWAY DESIGN ENGINEER	HYDRAULICS ENGINEER
INCOMPLETE PLANS DO NOT USE FOR R/W ACQUISITION	
DOCUMENT NOT CONSIDERED FINAL UNLESS ALL SIGNATURES COMPLETED	

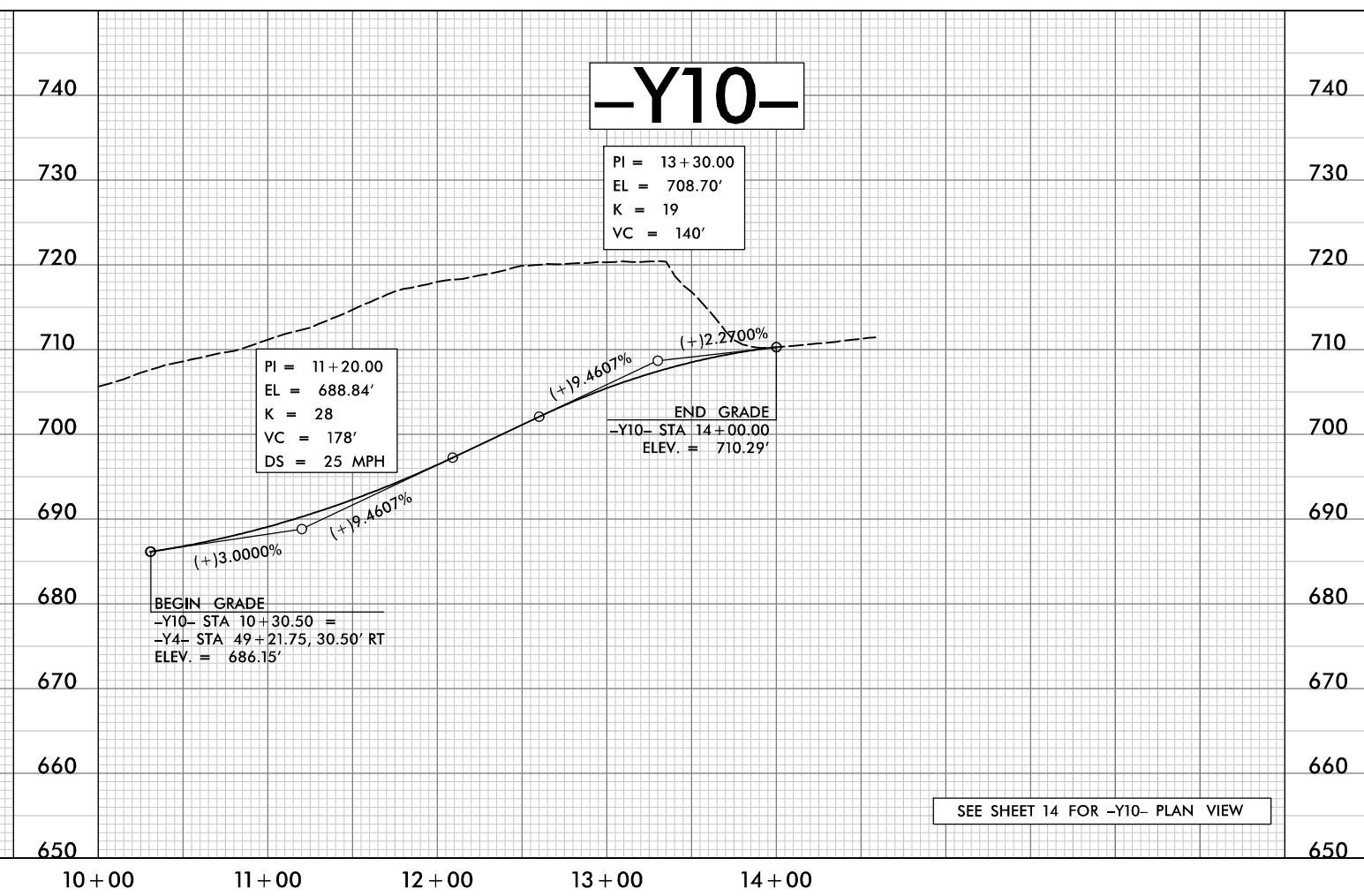
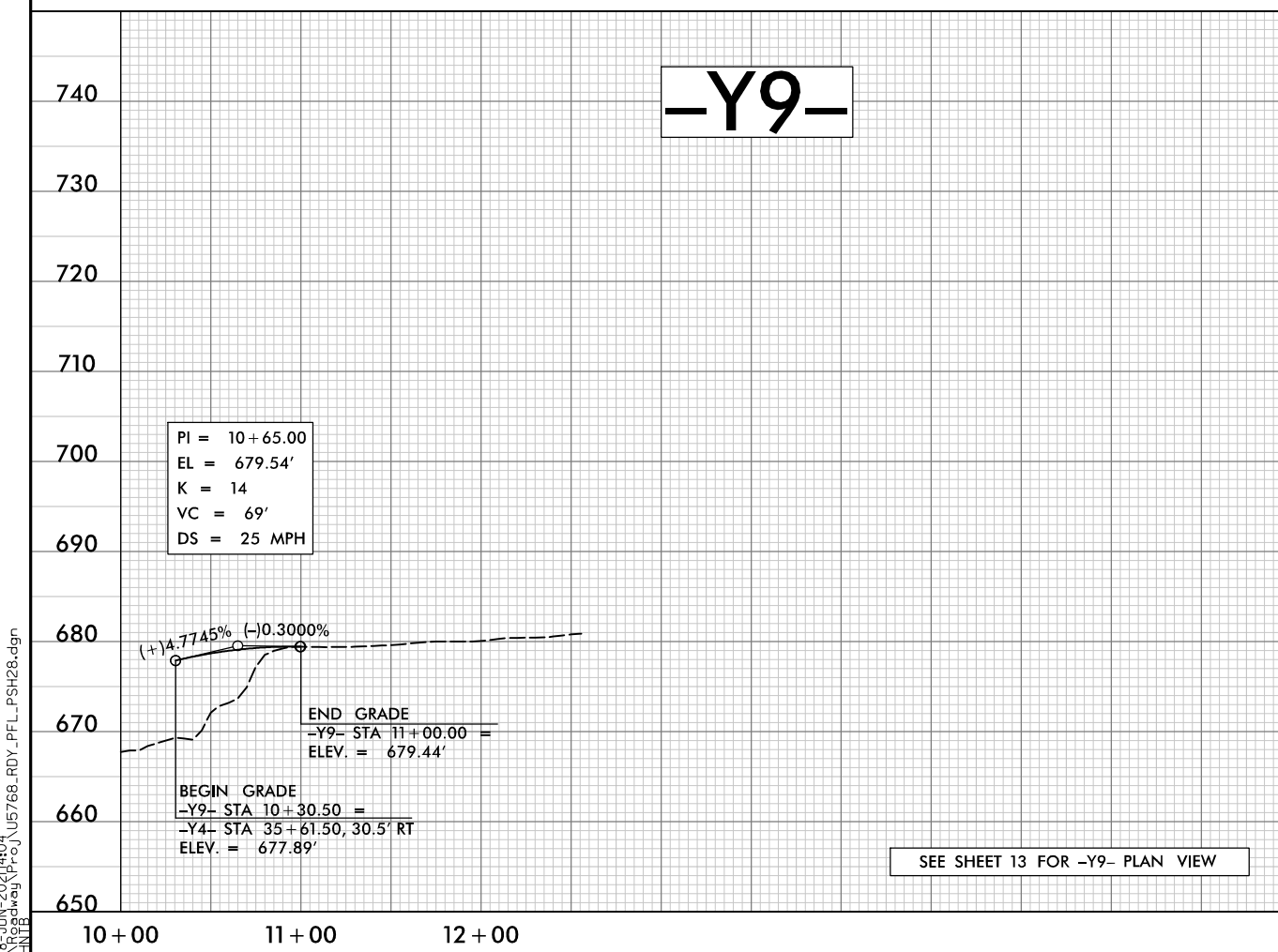
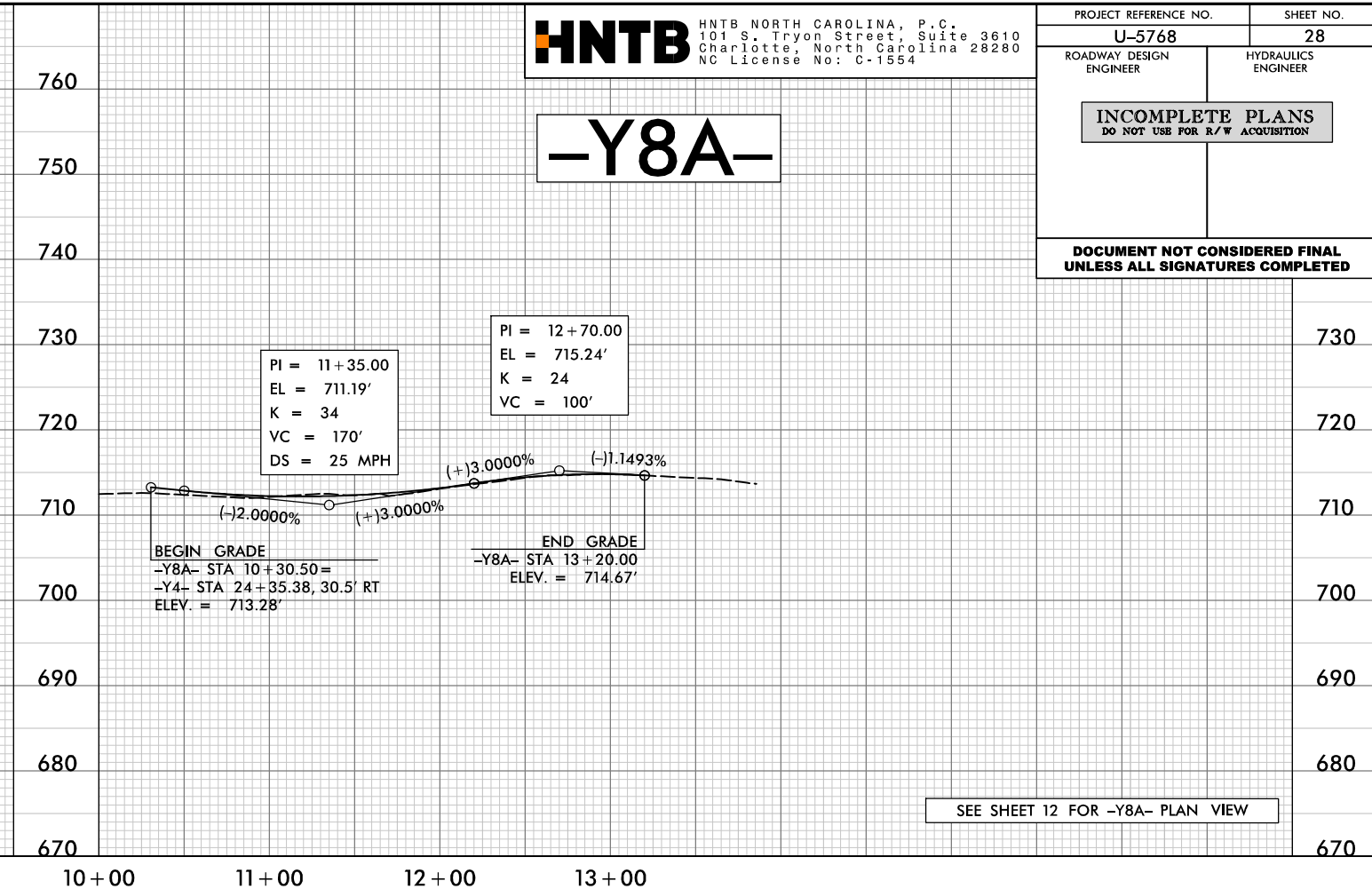
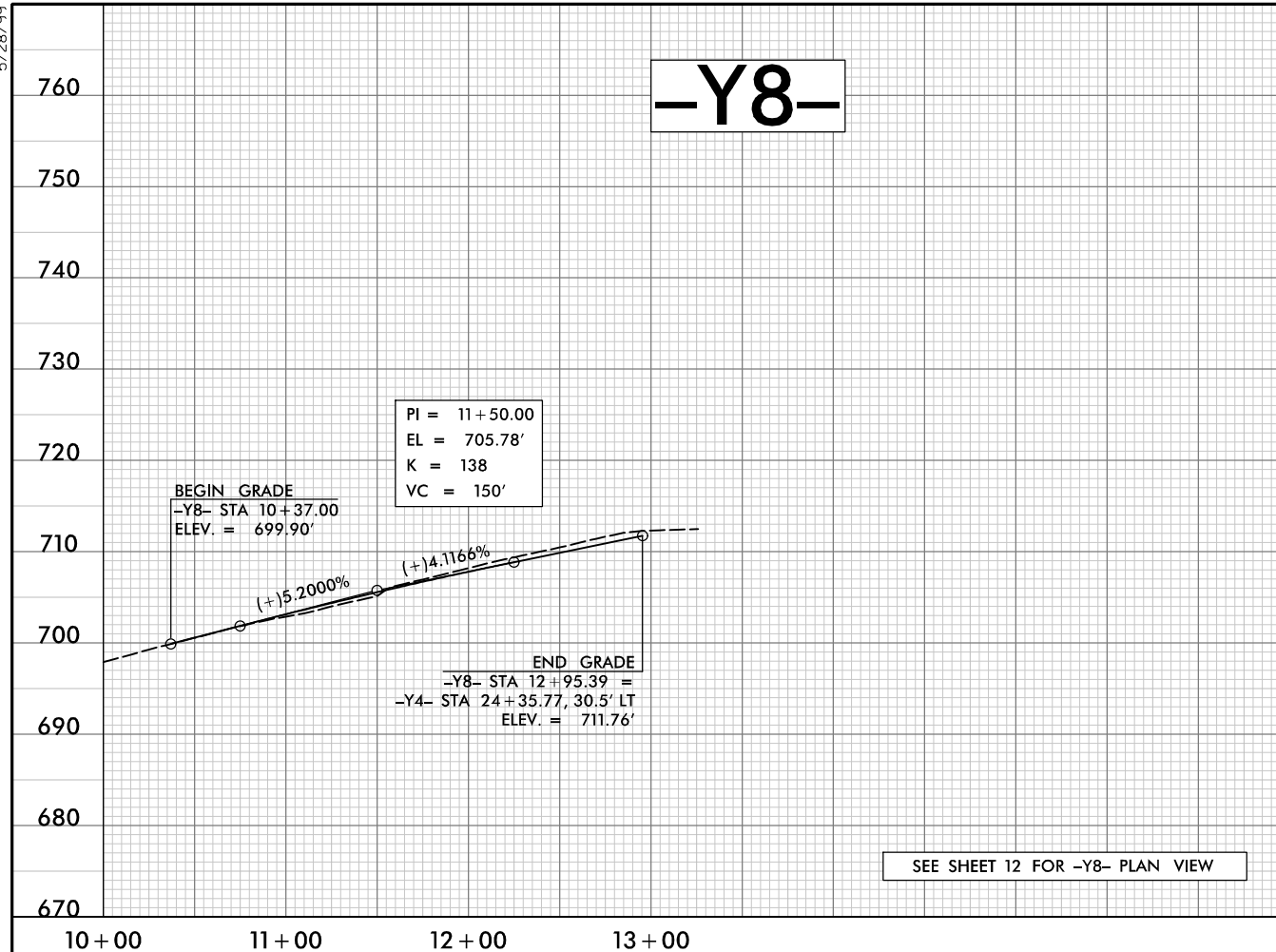

R:\JUN-2021\4404\Roadway\PC\U5768_RDY_PFL_PSH28.dgn

-Y11-

HNTB HNTB NORTH CAROLINA, P.C.
 101 S. Tryon Street, Suite 3610
 Charlotte, North Carolina 28280
 NC License No: C-1554

PROJECT REFERENCE NO.	SHEET NO.
U-5768	29
ROADWAY DESIGN ENGINEER	HYDRAULICS ENGINEER
INCOMPLETE PLANS DO NOT USE FOR R/W ACQUISITION	
DOCUMENT NOT CONSIDERED FINAL UNLESS ALL SIGNATURES COMPLETED	

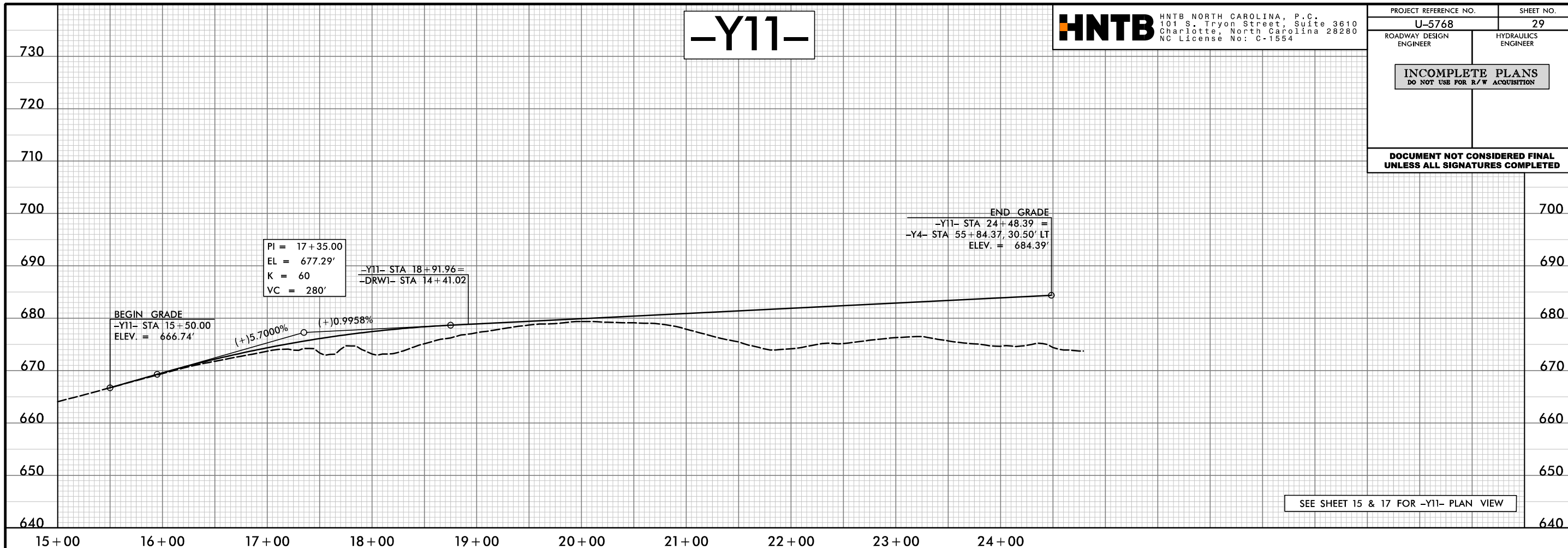

-Y12-

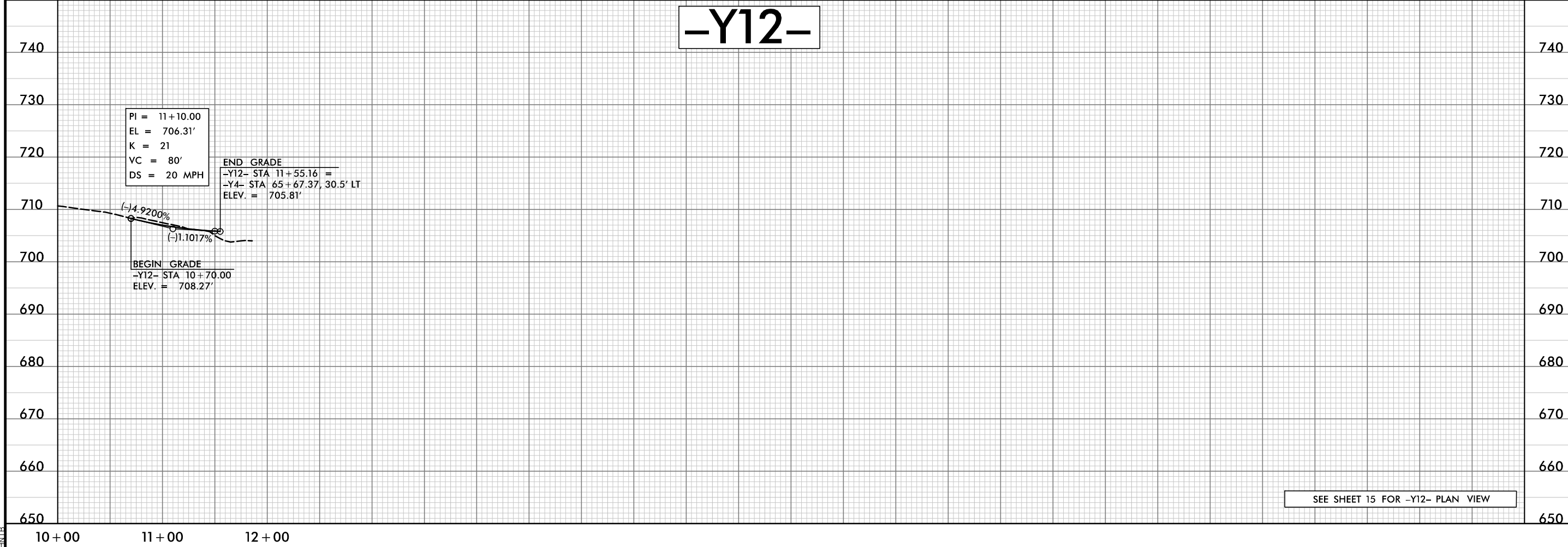

I:\JUN-2021\4404
 \Roadway\Project\U5768_RDY_PFL_PSH29.dgn
 HNTB

5/28/99

PROJECT REFERENCE NO.	SHEET NO.
U-5768	30
ROADWAY DESIGN ENGINEER	HYDRAULICS ENGINEER
INCOMPLETE PLANS DO NOT USE FOR R/W ACQUISITION	
DOCUMENT NOT CONSIDERED FINAL UNLESS ALL SIGNATURES COMPLETED	

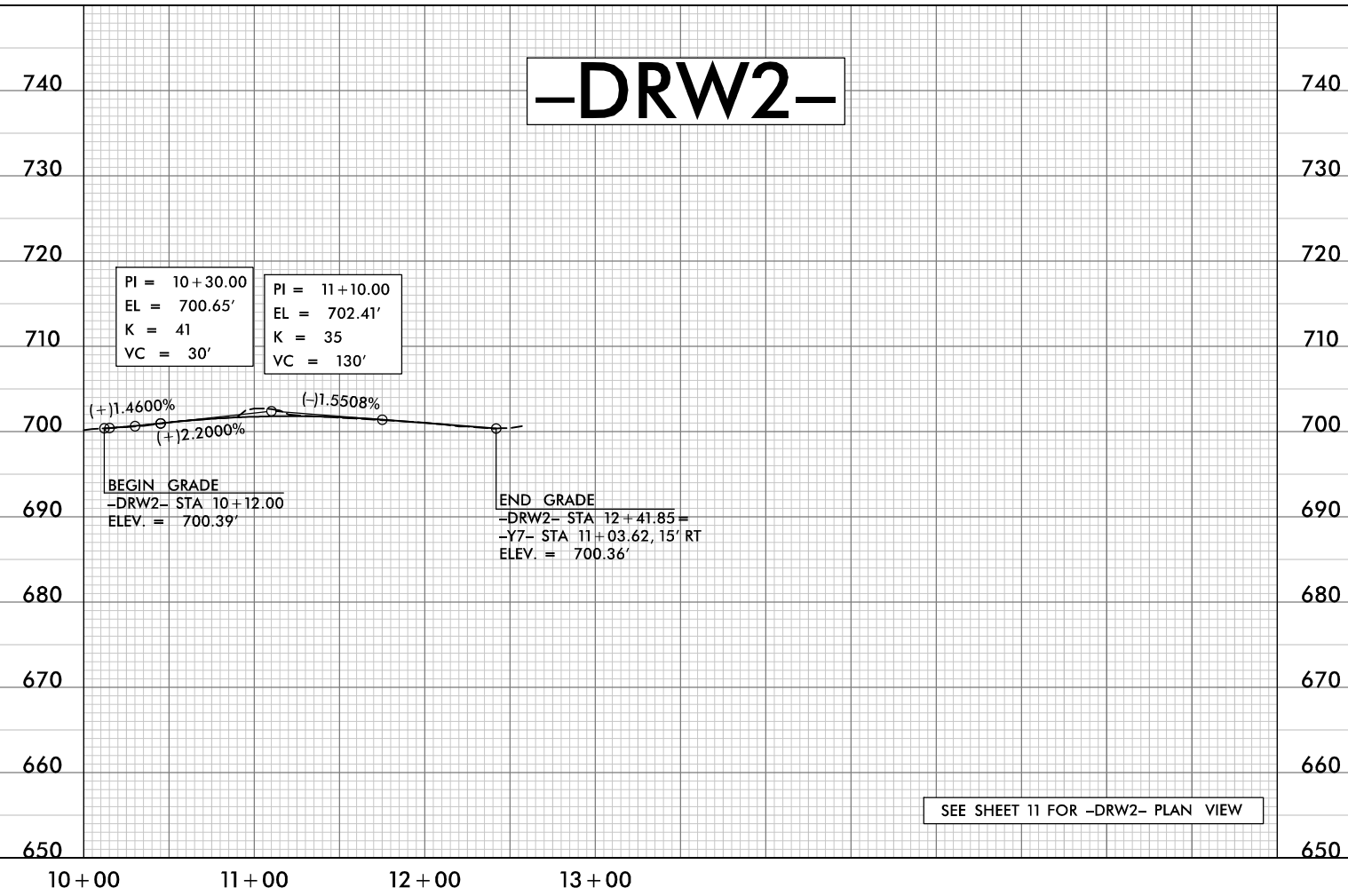
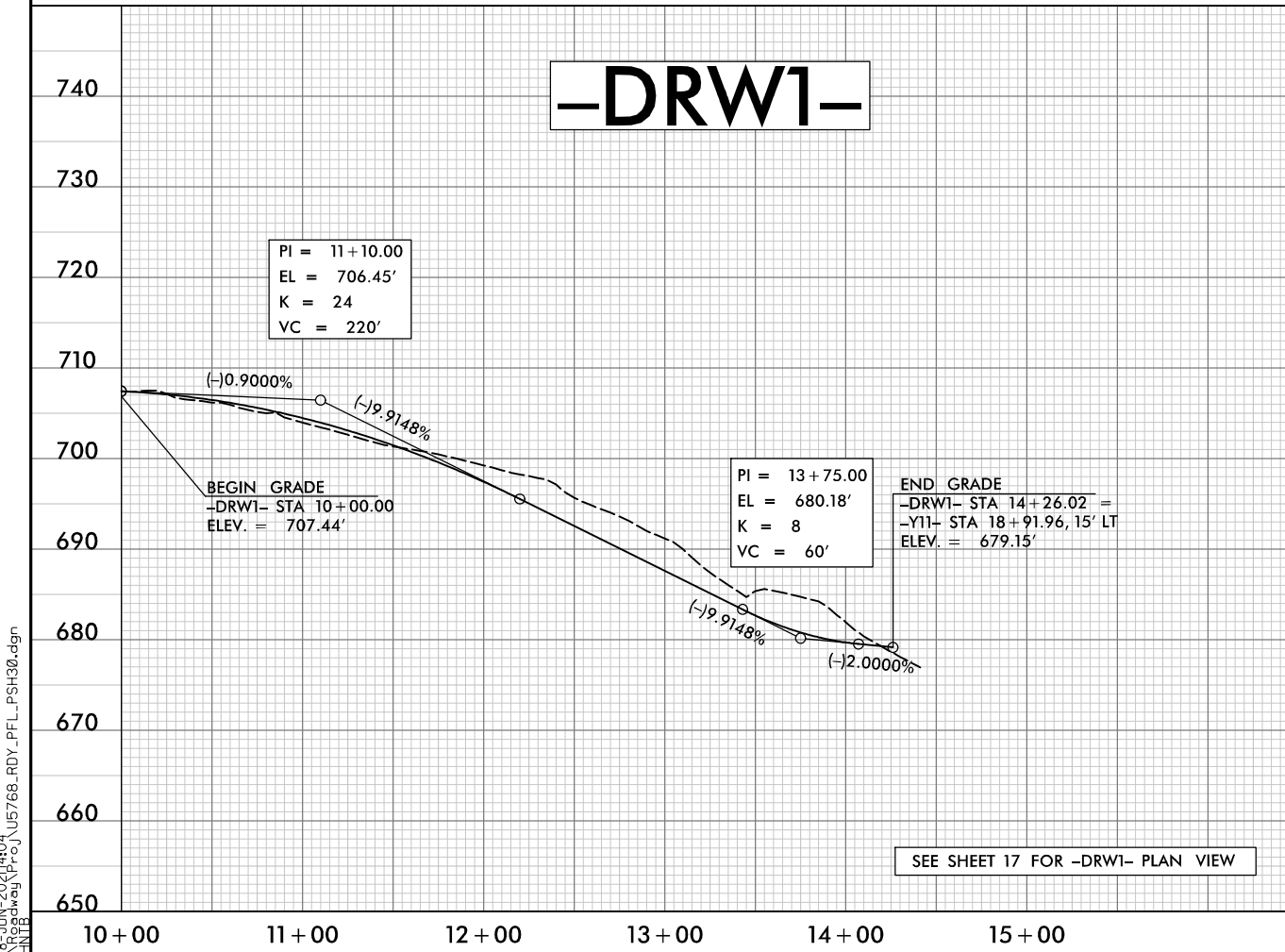
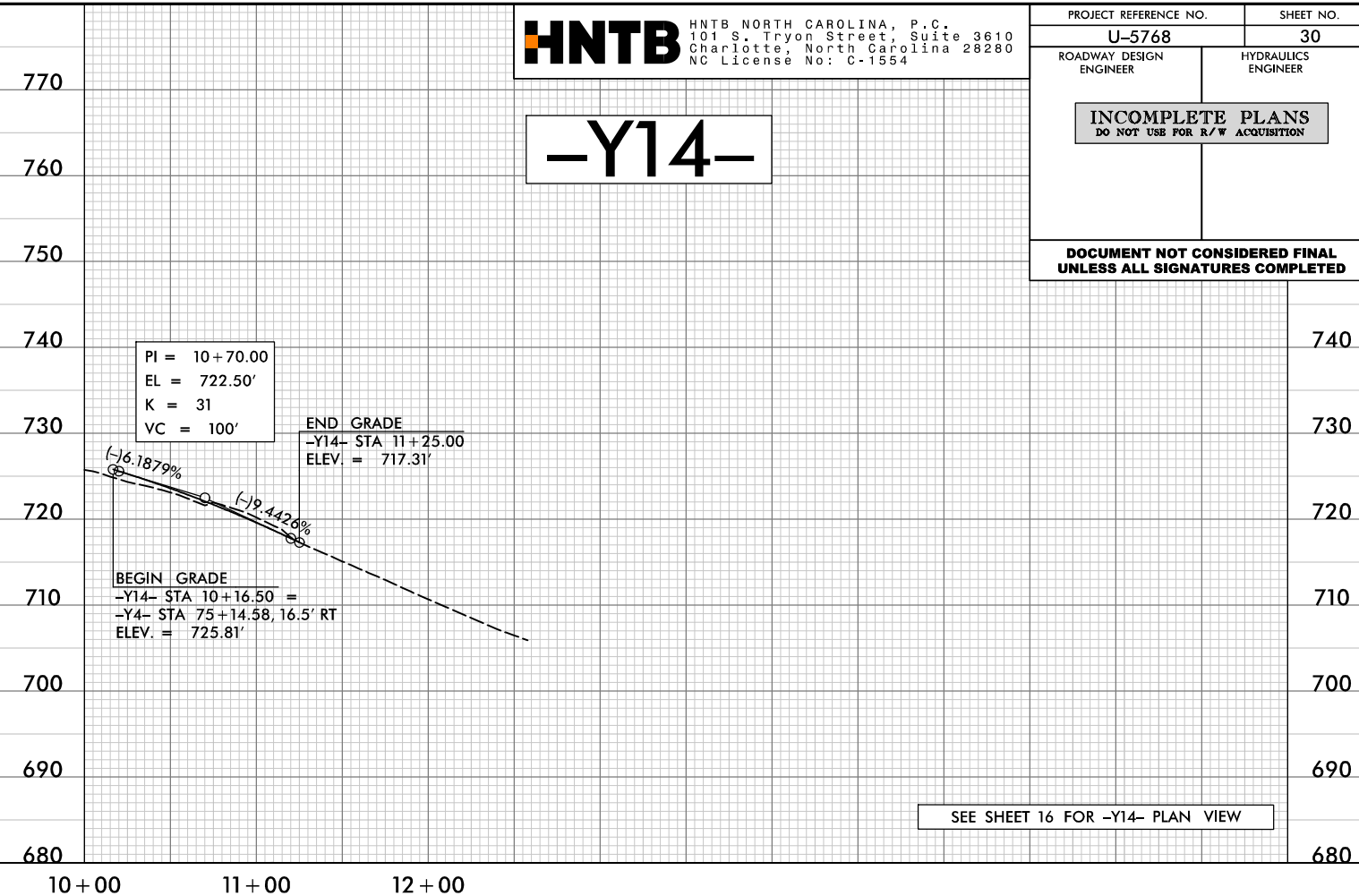
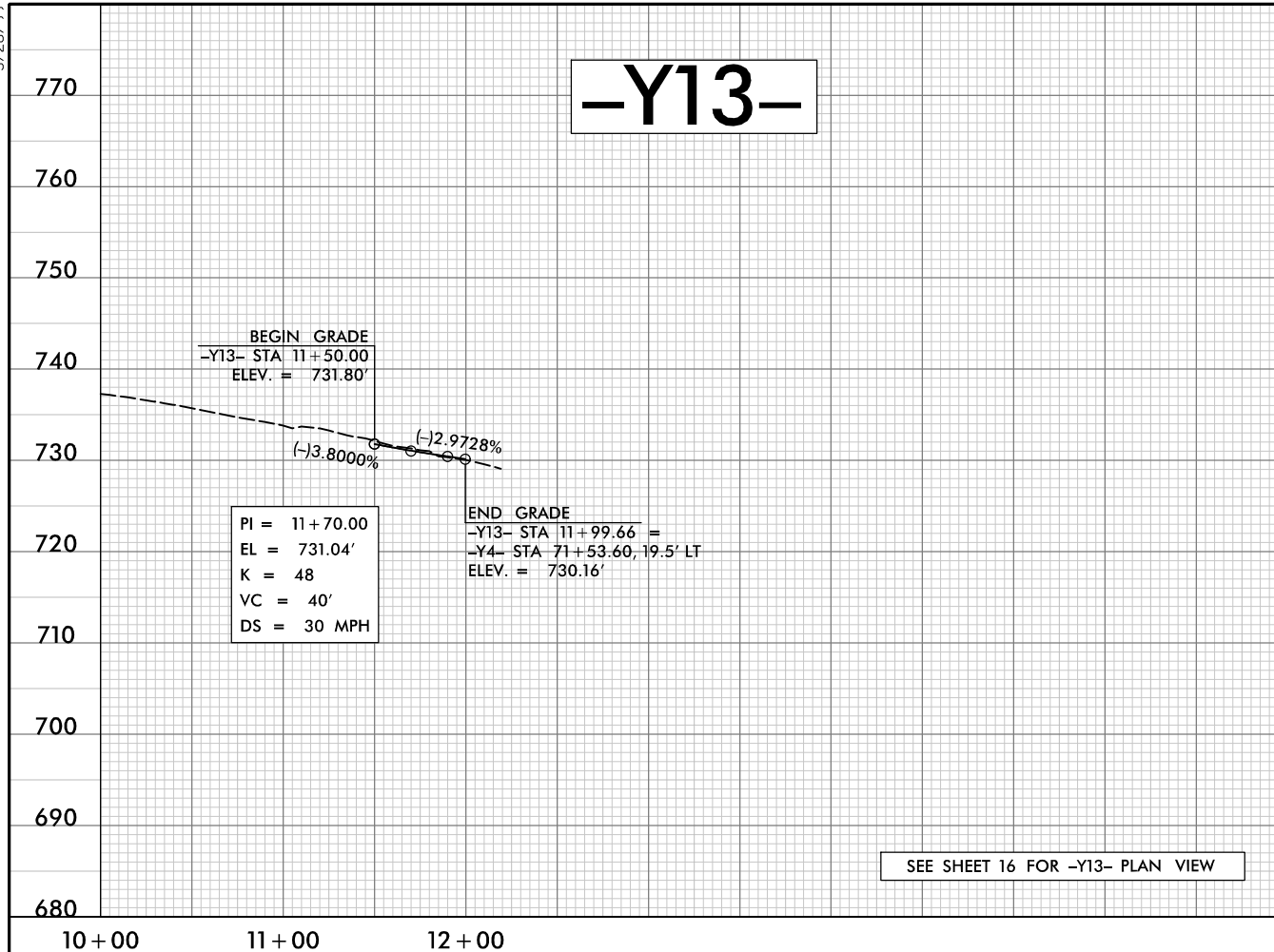

R:\JUN-2021\4404\Roadway\Project\U5768_RDY_PFL_PSH30.dgn