

09/08/2019

TIP PROJECT: W03293

CONTRACT: C205225

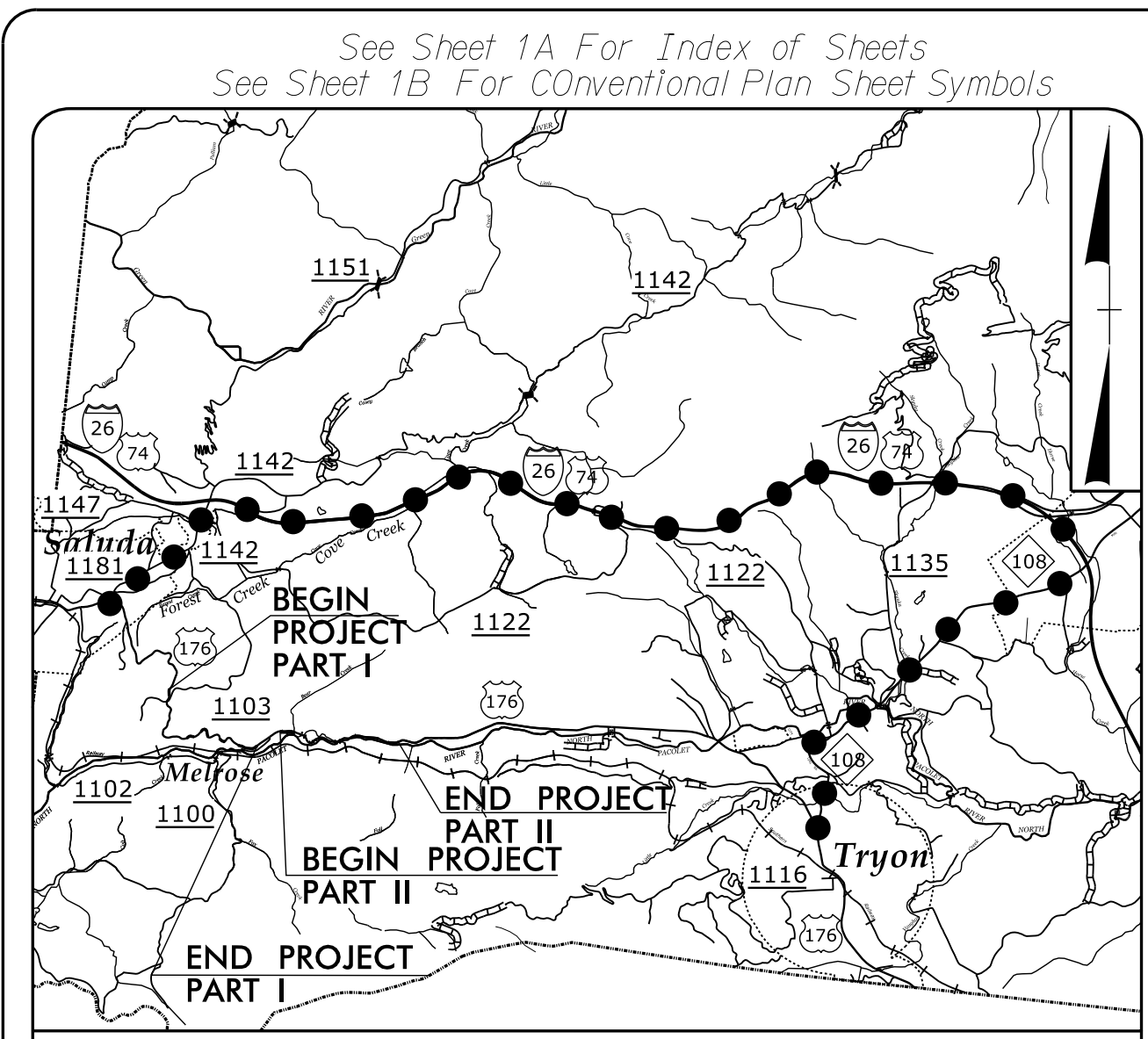

STATE OF NORTH CAROLINA
DIVISION OF HIGHWAYS
POLK COUNTY

LOCATION: US 176 FROM 0.1 MILES NORTH OF THOMPSON ROAD TO 0.8 MILES EAST OF BEAR CREEK LANE

TYPE OF WORK: GRADING, DRAINAGE, PAVING, AND RETAINING WALLS

STATE	STATE PROJECT REFERENCE NO.	SHEET NO.	TOTAL SHEETS
N.C.	W03293	1	
STATE PROJ. NO.	F.A. PROJ. NO.	DESCRIPTION	
18314.1075023		314	
18314.1075025		316	
18314.1075026		317	
18314.1075027		318	
18314.1075028		319	
18314.1075029		320	
18314.1075030		321	
18314.1075015		936	
18314.1075016		937	
18314.1075017		938	
18314.1075018		939	
18314.1075019		940	
18314.1075035		941	
18314.1075020		942	
18314.1075021		943	
18314.1075022		944	

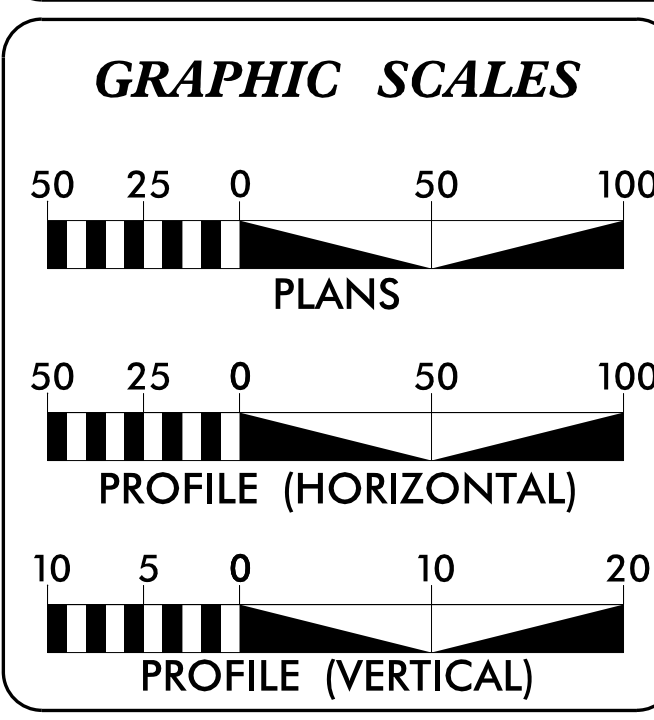
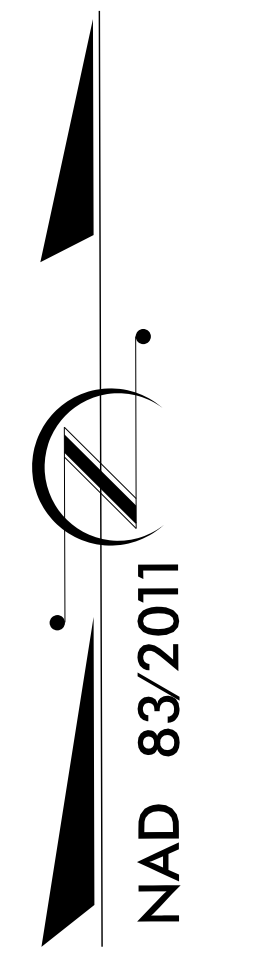
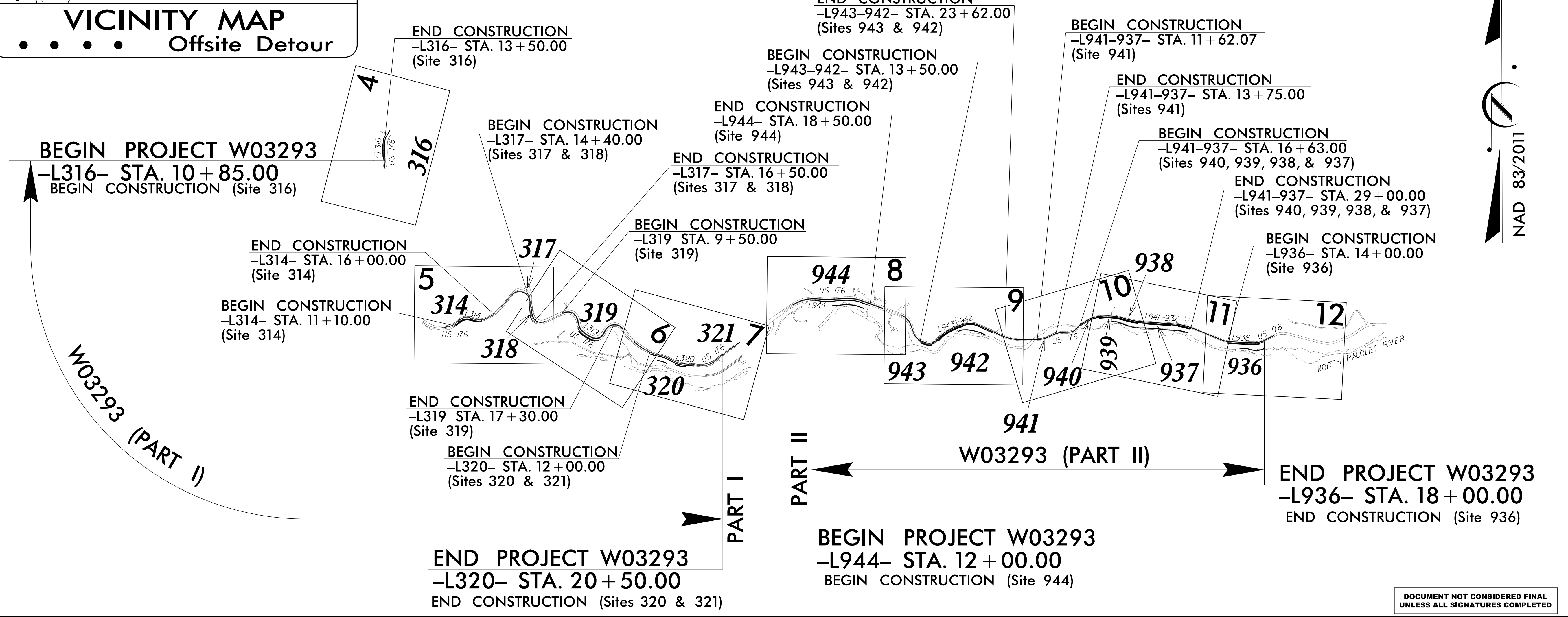

DESIGN DATA

ADT 2025 = 1,230
ADT 2050 = 1,570
V = 60 MPH

FUNC CLASS = MAJOR COLLECTOR SUBREGIONAL TIER

PROJECT LENGTH

TOTAL LENGTH ROADWAY PROJECT = 0.492 MILES
W03293 PART 1

TOTAL LENGTH ROADWAY PROJECT = 0.665 MILES
W03293 PART 2

TOTAL LENGTH ROADWAY PROJECT = 1.157 MILES
W03293

NC DOT CONTACT: JEANETTE WHITE, PE

PLANS PREPARED BY:
TGS ENGINEERS
201 W. MARION ST., STE 200
SHELBY, NC 28150
PH (704) 476-0003
CORP. LICENSE NO.: C-0275

PLANS PREPARED FOR:
NORTH CAROLINA DEPARTMENT OF TRANSPORTATION
DIVISION 14
252 Webster Rd
Sylva, NC 28779

RIGHT OF WAY DATE:
AUG. 29, 2025 (300s)
AUG 12, 2025 (900s)

LETTING DATE:
JULY 21, 2026

JIMMY L. TERRY, PE
PROJECT ENGINEER

AUSTIN R. TURNER, PE
PROJECT DESIGN ENGINEER

2024 STANDARD SPECIFICATIONS

HYDRAULICS ENGINEER

5/21/2026

Signed by: **John W. Twissdale, Jr.** P.E.
SIGNATURE PAGE

ROADWAY DESIGN ENGINEER

5/21/2026

DocuSigned by: **Jimmy Terry** P.E.
SIGNATURE PAGE

Professional Engineer Seals for John W. Twissdale, Jr. (Seal 024897) and Jimmy L. Terry (Seal 35018).

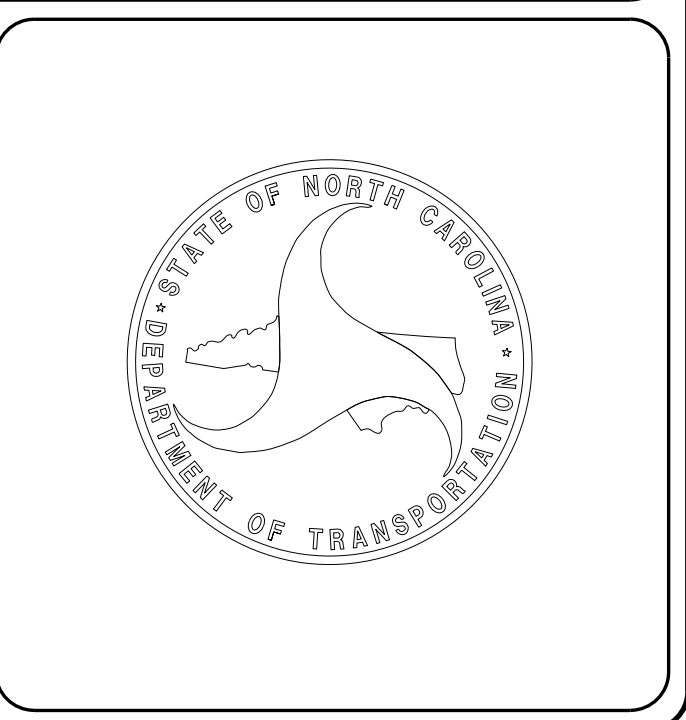

DOCUMENT NOT CONSIDERED FINAL UNLESS ALL SIGNATURES COMPLETED

5/21/2026 X:\NCDOT\Div 14 US 176 Repair\Roadway\Design\Title_Typicals_Detalls_Summaries\US176_Rdy_+tsh_Combined.dgn User:rtturner

8/17/99
12/30/2025
X:\NCD001\Div 14 US 176 Repair\Roadway\Design\Title_Typicals_Details_Summaries\US176_Rdy_tah_Combined.dgn

INDEX OF SHEETS



TGS ENGINEERS
201 W. MARION ST., STE 200
SHELBY, NC 28150
PH (704) 476-0003
CORP. LICENSE NO.: C-0275

PROJECT REFERENCE NO.	SHEET NO.
W03293	1A

DOCUMENT NOT CONSIDERED FINAL
UNLESS ALL SIGNATURES COMPLETED

STANDARD DRAWINGS



EFF. 08-11-2025
REV.

2024 ROADWAY ENGLISH STANDARD DRAWINGS

The following Roadway Standards as appear in "Roadway Standard Drawings" Contracts Standards and Development Unit - N. C. Department of Transportation - Raleigh, N. C., Dated January 16, 2024 are applicable to this project and by reference hereby are considered a part of these plans:

STD.NO.	TITLE
DIVISION 2 - EARTHWORK	
200.02	Method of Clearing - Method II
225.02	Guide for Grading Subgrade - Secondary and Local
225.04	Method of Obtaining Superelevation - Two Lane Pavement
275.01	Rock Plating
DIVISION 3 - PIPE CULVERTS	
300.01	Method of Pipe Installation (Use Details in Lieu of Standards for Sheets 1 and 2 of 2)
DIVISION 5 - SUBGRADE, BASES AND SHOULDERS	
560.01	Method of Shoulder Construction - High Side of Superelevated Curve - Method I
DIVISION 6 - ASPHALT BASES AND PAVEMENTS	
654.01	Pavement Repairs
DIVISION 8 - INCIDENTALS	
815.02	Subsurface Drain
838.01	Concrete Endwall for Single and Double Pipe Culverts - 15" thru 48" Pipe 90 Skew
838.11	Brick Endwall for Single and Double Pipe Culverts - 15" thru 48" Pipe 90 Skew
838.80	Precast Endwalls - 12" thru 72" Pipe 90 Skew
840.00	Concrete Base Pad for Drainage Structures
840.25	Anchorage for Frames - Brick or Concrete or Precast
840.29	Frames and Narrow Slot Flat Grates
840.35	Traffic Bearing Grated Drop Inlet - for Cast Iron Double Frame and Grates
840.37	Steel Grate and Frame
840.46	Traffic Bearing Precast Drainage Structure
850.01	Concrete Paved Ditches
840.66	Drainage Structure Steps
840.71	Concrete and Brick Pipe Plug
846.01	Concrete Curb, Gutter and Curb & Gutter
846.04	Drop Inlet Installation in Shoulder Berm Gutter
862.01	Guardrail Placement (Use Details in Lieu of Standards for Sheets 4, 6, 11, 12, and 14 of 15)
862.02	Guardrail Installation (Use Details in Lieu of Standards for Sheet 5 of 9)
876.01	Rip Rap in Channels and Ditches
876.02	Guide for Rip Rap at Pipe Outlets

SHEET NUMBER	SHEET
1	TITLE SHEET
1A	INDEX OF SHEETS, GENERAL NOTES, AND STANDARD DRAWINGS
1B	CONVENTIONAL SYMBOLS

W03293 PART I INDEX OF SHEETS	
SHEET NUMBER	SHEET
1	TITLE SHEET
2A-1	PAVEMENT SCHEDULE AND TYPICAL SECTIONS
2C-1 THRU 2C-2	SPECIAL DETAIL - METHOD OF PIPE INSTALLATION
2C-3	SPECIAL DETAIL - GUARDRAIL PLACEMENT
2C-4	SPECIAL DETAIL - GUARDRAIL INSTALLATION
2C-5	SPECIAL DETAIL - GUARDRAIL PLACEMENT
2D-1	DRAINAGE DETAIL - TRAFFIC BEARING GRATED INLET
2G-1	GEOTECHNICAL DETAIL - ROCK EMBANKMENT SITE 314
3B-1 THRU 3B-3	ROADWAY SUMMARIES (EARTHWORK, PAVEMENT REMOVAL, & SHOULDER BERM GUTTER)
3B-4	GUARDRAIL SUMMARY
3D-1 THRU 3D-2	DRAINAGE SUMMARIES
3G-1	GEOTECHNICAL SUMMARIES
3P-1	PARCEL INDEX SHEET
4 THRU 7	PLAN SHEETS
8	PROFILE SHEET
RW-1 THRU RW-7	SURVEY CONTROL SHEETS
TMP-1 THRU TMP-12	TRANSPORTATION MANAGEMENT PLANS
PMP-1 THRU PMP-5	PAVEMENT MARKING PLANS
EC-1 THRU EC-11	EROSION CONTROL PLANS
RF-1	REFORESTATION DETAIL SHEET
SIGN-1 THRU SIGN-6	SIGNING PLANS
UO-1 THRU UO-7	UTILITIES BY OTHERS PLANS
X-1	CROSS-SECTION INDEX SHEET
X-1A	CROSS-SECTION SUMMARY SHEET
X-2 THRU X-49	CROSS-SECTIONS
W-1 THRU W-3	SITE 316 RETAINING WALL
W-4 THRU W-5	SITE 314 RETAINING WALL
W-6 THRU W-7	SITE 319 RETAINING WALL
W-8 THRU W-10	SITE 320 RETAINING WALL

W03293 PART II INDEX OF SHEETS	
SHEET NUMBER	SHEET
1	TITLE SHEET
2A-1 THRU 2A-2	PAVEMENT SCHEDULE AND TYPICAL SECTIONS
2C-1 THRU 2C-2	SPECIAL DETAIL - METHOD OF PIPE INSTALLATION
2C-3	SPECIAL DETAIL - GUARDRAIL PLACEMENT
2C-4	SPECIAL DETAIL - GUARDRAIL INSTALLATION
2C-5	SPECIAL DETAIL - GUARDRAIL PLACEMENT
2D-1	DRAINAGE DETAIL - TRAFFIC BEARING GRATED INLET
2G-1 THRU 2G-2	GEOTECHNICAL DETAIL - SITE 941 WIRE FORM EMBANKMENT
2G-3	GEOTECHNICAL DETAIL - SITE 940 ROCK EMBANKMENTS
3B-1 THRU 3B-3	ROADWAY SUMMARIES (EARTHWORK, PAVEMENT REMOVAL, SHOULDER BERM GUTTER, & 8" CURB)
3B-4	GUARDRAIL SUMMARY
3D-1 THRU 3D-2	DRAINAGE SUMMARIES
3G-1	GEOTECHNICAL SUMMARIES
3P-1	PARCEL INDEX SHEET
8 THRU 12	PLAN SHEETS
RW-1 THRU RW-12	SURVEY CONTROL SHEETS
TMP-1 THRU TMP-6	TRANSPORTATION MANAGEMENT PLANS
PMP-1 THRU PMP-6	PAVEMENT MARKING PLANS
EC-1 THRU EC-13	EROSION CONTROL PLANS
RF-1	REFORESTATION DETAIL SHEET
SIGN-1 THRU SIGN-7	SIGNING PLANS
UO-1; UO-8 THRU UO-12	UTILITIES BY OTHERS PLANS
X-1	CROSS-SECTION INDEX SHEET
X-1A	CROSS-SECTION SUMMARY SHEET
X-2 THRU X-70	CROSS-SECTIONS
W-1 THRU W-5	SITE 944 RETAINING WALL
W-6 THRU W-7	SITE 943 RETAINING WALL
W-8 THRU W-11	SITE 942 RETAINING WALL
W-12 THRU W-15	SITES 938/938 RETAINING WALL
W-16 THRU W-19	SITE 937 RETAINING WALL
W-20 THRU W-23	SITE 936 RETAINING WALL
W-24 THRU W-25	PARTIALLY GROUTED ROCK FILL NOTES & DETAILS

GENERAL NOTES

2024 SPECIFICATIONS
EFFECTIVE: 01-16-2024
REVISED:

GRADING AND SURFACING OR RESURFACING AND WIDENING:

THE GRADE LINES SHOWN DENOTE THE FINISHED ELEVATION OF THE PROPOSED SURFACING AT GRADE POINTS SHOWN ON THE TYPICAL SECTIONS. WHERE NO GRADE LINES ARE SHOWN, THE PROFILES SHOWN DENOTE THE TOP ELEVATION OF THE EXISTING PAVEMENT ALONG THE CENTER LINE OF SURVEY ON WHICH THE PROPOSED RESURFACING WILL BE PLACED. GRADE LINES MAY BE ADJUSTED BY THE ENGINEER IN ORDER TO SECURE A PROPER TIE-IN.

CLEARING:

CLEARING ON THIS PROJECT SHALL BE PERFORMED TO THE LIMITS ESTABLISHED BY METHOD II.

SUPERELEVATION:

ALL CURVES ON THIS PROJECT SHALL BE SUPERELEVATED IN ACCORDANCE WITH STD. NO. 225.04 USING THE RATE OF SUPERELEVATION AND RUNOFF SHOWN ON THE PLANS. SUPERELEVATION IS TO BE REVOLVED ABOUT THE GRADE POINTS SHOWN ON THE TYPICAL SECTIONS.

SHOULDER CONSTRUCTION:

ASPHALT, EARTH, AND CONCRETE SHOULDER CONSTRUCTION ON THE HIGH SIDE OF SUPERELEVATED CURVES SHALL BE IN ACCORDANCE WITH STD. NO. 560.01

SUBSURFACE DRAINS:

SUBSURFACE DRAINS SHALL BE CONSTRUCTED IN ACCORDANCE WITH STD. NO. 815.02 AT LOCATIONS DIRECTED BY THE ENGINEER.

GUARDRAIL:

THE GUARDRAIL LOCATIONS SHOWN ON THE PLANS MAY BE ADJUSTED DURING CONSTRUCTION AS DIRECTED BY THE ENGINEER. THE CONTRACTOR SHOULD CONSULT WITH THE ENGINEER PRIOR TO ORDERING GUARDRAIL MATERIAL.

TEMPORARY SHORING:

SHORING REQUIRED FOR THE MAINTENANCE OF TRAFFIC NOT SHOWN ON THE PLANS WILL BE PAID FOR AT THE CONTRACT PRICE FOR "TEMPORARY SHORING".

UTILITIES:

UTILITY OWNERS ON THIS PROJECT ARE DUKE ENERGY, MCNC, DUKE FIBER, AND RIVER STREET.

ANY RELOCATION OF EXISTING UTILITIES WILL BE ACCOMPLISHED BY OTHERS, EXCEPT AS SHOWN ON THE PLANS.

RIGHT-OF-WAY MARKERS:

ALL RIGHT-OF-WAY MARKERS ON THIS PROJECT SHALL BE PLACED BY OTHERS.

05/20/24

Note: Not to Scale

STATE OF NORTH CAROLINA, DIVISION OF HIGHWAYS CONVENTIONAL PLAN SHEET SYMBOLS

BOUNDARIES AND PROPERTY:

State Line	_____
County Line	_____
Township Line	_____
City Line	_____
Reservation Line	_____
Property Line	_____
Existing Iron Pin (EIP)	○
Computed Property Corner	X
Existing Concrete Monument (ECM)	□
Parcel / Sequence Number	123
Existing Fence Line	-x-x-x-
Proposed Woven Wire Fence	○
Proposed Chain Link Fence	□
Proposed Barbed Wire Fence	◇
Existing Wetland Boundary	---WLB---
Proposed Wetland Boundary	---WLB---
Existing Endangered Animal Boundary	---EAB---
Existing Endangered Plant Boundary	---EPB---
Existing Historic Property Boundary	---HPB---
Known Contamination Area: Soil	---S---
Potential Contamination Area: Soil	---S---
Known Contamination Area: Water	---W---
Potential Contamination Area: Water	---W---
Contaminated Site: Known or Potential	☠☢
BUILDINGS AND OTHER CULTURE:	
Gas Pump Vent or U/G Tank Cap	○
Sign	○
Well	○
Small Mine	✕
Foundation	□
Area Outline	□
Cemetery	□
Building	□
School	□
Church	□
Dam	_____
HYDROLOGY:	
Stream or Body of Water	_____
Hydro, Pool or Reservoir	□
Jurisdictional Stream	---JS---
Buffer Zone 1	---BZ 1---
Buffer Zone 2	---BZ 2---
Flow Arrow	←
Disappearing Stream	→
Spring	○
Wetland	✕
Proposed Lateral, Tail, Head Ditch	→
False Sump	◁

RAILROADS:

Standard Gauge	_____
RR Signal Milepost	○
Switch	□
RR Abandoned	_____
RR Dismantled	_____

RIGHT OF WAY & PROJECT CONTROL:

Primary Horiz Control Point	○
Primary Horiz and Vert Control Point	●
Secondary Horiz and Vert Control Point	◆
Vertical Benchmark	⊠
Existing Right of Way Monument	△
Proposed Right of Way Monument (Rebar and Cap)	▲
Proposed Right of Way Monument (Concrete)	⊙
Existing Permanent Easement Monument	◇
Proposed Permanent Easement Monument (Rebar and Cap)	◆
Existing C/A Monument	△
Proposed C/A Monument (Rebar and Cap)	▲
Proposed C/A Monument (Concrete)	⊙
Existing Right of Way Line	_____
Proposed Right of Way Line	_____
Existing Control of Access Line	_____
Proposed Control of Access Line	_____
Proposed ROW and CA Line	_____
Existing Easement Line	---E---
Proposed Temporary Construction Easement	---E---
Proposed Temporary Drainage Easement	---TDE---
Proposed Permanent Drainage Easement	---PDE---
Proposed Permanent Drainage/Utility Easement	---DUE---
Proposed Permanent Utility Easement	---PUE---
Proposed Temporary Utility Easement	---TUE---
Proposed Aerial Utility Easement	---AUE---

ROADS AND RELATED FEATURES:

Existing Edge of Pavement	_____
Existing Curb	_____
Proposed Slope Stakes Cut	---C---
Proposed Slope Stakes Fill	---F---
Proposed Curb Ramp	○
Existing Metal Guardrail	_____
Proposed Guardrail	_____
Existing Cable Guiderail	_____
Proposed Cable Guiderail	_____
Equality Symbol	⊕
Pavement Removal	_____

VEGETATION:

Single Tree	○
Single Shrub	○
Hedge	_____

Woods Line	_____
Orchard	_____
Vineyard	_____

EXISTING STRUCTURES:

MAJOR:	
Bridge, Tunnel or Box Culvert	_____
Bridge Wing Wall, Head Wall and End Wall	_____
MINOR:	
Head and End Wall	_____
Pipe Culvert	_____
Footbridge	_____
Drainage Box: Catch Basin, DI or JB	□
Paved Ditch Gutter	_____
Storm Sewer Manhole	○
Storm Sewer	_____

UTILITIES:

* SUE - Subsurface Utility Engineering
LOS - Level of Service - A,B,C or D (Accuracy)

POWER:	
Existing Power Pole	●
Proposed Power Pole	○
Existing Joint Use Pole	●
Proposed Joint Use Pole	○
Power Manhole	○
Power Line Tower	⊠
Power Transformer	⊠
U/G Power Cable Hand Hole	□
H-Frame Pole	●
U/G Power Line Test Hole (SUE - LOS A)*	⊙
U/G Power Line (SUE - LOS B)*	---P---
U/G Power Line (SUE - LOS C)*	---P---
U/G Power Line (SUE - LOS D)*	---P---
TELEPHONE:	
Existing Telephone Pole	●
Proposed Telephone Pole	○
Telephone Manhole	○
Telephone Pedestal	⊠
Telephone Cell Tower	⊠
U/G Telephone Cable Hand Hole	□
U/G Telephone Test Hole (SUE - LOS A)*	⊙
U/G Telephone Cable (SUE - LOS B)*	---T---
U/G Telephone Cable (SUE - LOS C)*	---T---
U/G Telephone Cable (SUE - LOS D)*	---T---
U/G Telephone Conduit (SUE - LOS B)*	---TC---
U/G Telephone Conduit (SUE - LOS C)*	---TC---
U/G Telephone Conduit (SUE - LOS D)*	---TC---
U/G Fiber Optics Cable (SUE - LOS B)*	---TFO---
U/G Fiber Optics Cable (SUE - LOS C)*	---TFO---
U/G Fiber Optics Cable (SUE - LOS D)*	---TFO---

WATER:

Water Manhole	○
Water Meter	○
Water Valve	⊗
Water Hydrant	⊙
U/G Water Line Test Hole (SUE - LOS A)*	⊙
U/G Water Line (SUE - LOS B)*	---W---
U/G Water Line (SUE - LOS C)*	---W---
U/G Water Line (SUE - LOS D)*	---W---
Above Ground Water Line	---A/G Water---

TV:

TV Pedestal	⊠
TV Tower	⊗
U/G TV Cable Hand Hole	□
U/G TV Test Hole (SUE - LOS A)*	⊙
U/G TV Cable (SUE - LOS B)*	---TV---
U/G TV Cable (SUE - LOS C)*	---TV---
U/G TV Cable (SUE - LOS D)*	---TV---
U/G Fiber Optic Cable (SUE - LOS B)*	---TV FO---
U/G Fiber Optic Cable (SUE - LOS C)*	---TV FO---
U/G Fiber Optic Cable (SUE - LOS D)*	---TV FO---

GAS:

Gas Valve	◇
Gas Meter	⊙
U/G Gas Line Test Hole (SUE - LOS A)*	⊙
U/G Gas Line (SUE - LOS B)*	---G---
U/G Gas Line (SUE - LOS C)*	---G---
U/G Gas Line (SUE - LOS D)*	---G---
Above Ground Gas Line	---A/G Gas---

SANITARY SEWER:

Sanitary Sewer Manhole	⊙
Sanitary Sewer Cleanout	⊕
U/G Sanitary Sewer Line	---SS---
Above Ground Sanitary Sewer	---A/G Sanitary Sewer---
SS Force Main Line Test Hole (SUE - LOS A)*	⊙
SS Force Main Line (SUE - LOS B)*	---FSS---
SS Force Main Line (SUE - LOS C)*	---FSS---
SS Force Main Line (SUE - LOS D)*	---FSS---

MISCELLANEOUS:

Utility Pole	●
Utility Pole with Base	⊠
Utility Located Object	○
Utility Traffic Signal Box	⊠
Utility Unknown U/G Line (SUE - LOS B)*	---ZUL---
U/G Tank; Water, Gas, Oil	□
Underground Storage Tank, Approx. Loc.	⊠
A/G Tank; Water, Gas, Oil	□
Geoenvironmental Boring	⊙
Abandoned According to Utility Records	AATUR
End of Information	E.O.I.

PROJECT: W03293

See Sheet 1A For Index of Sheets
See Sheet 1B For Conventional Symbols

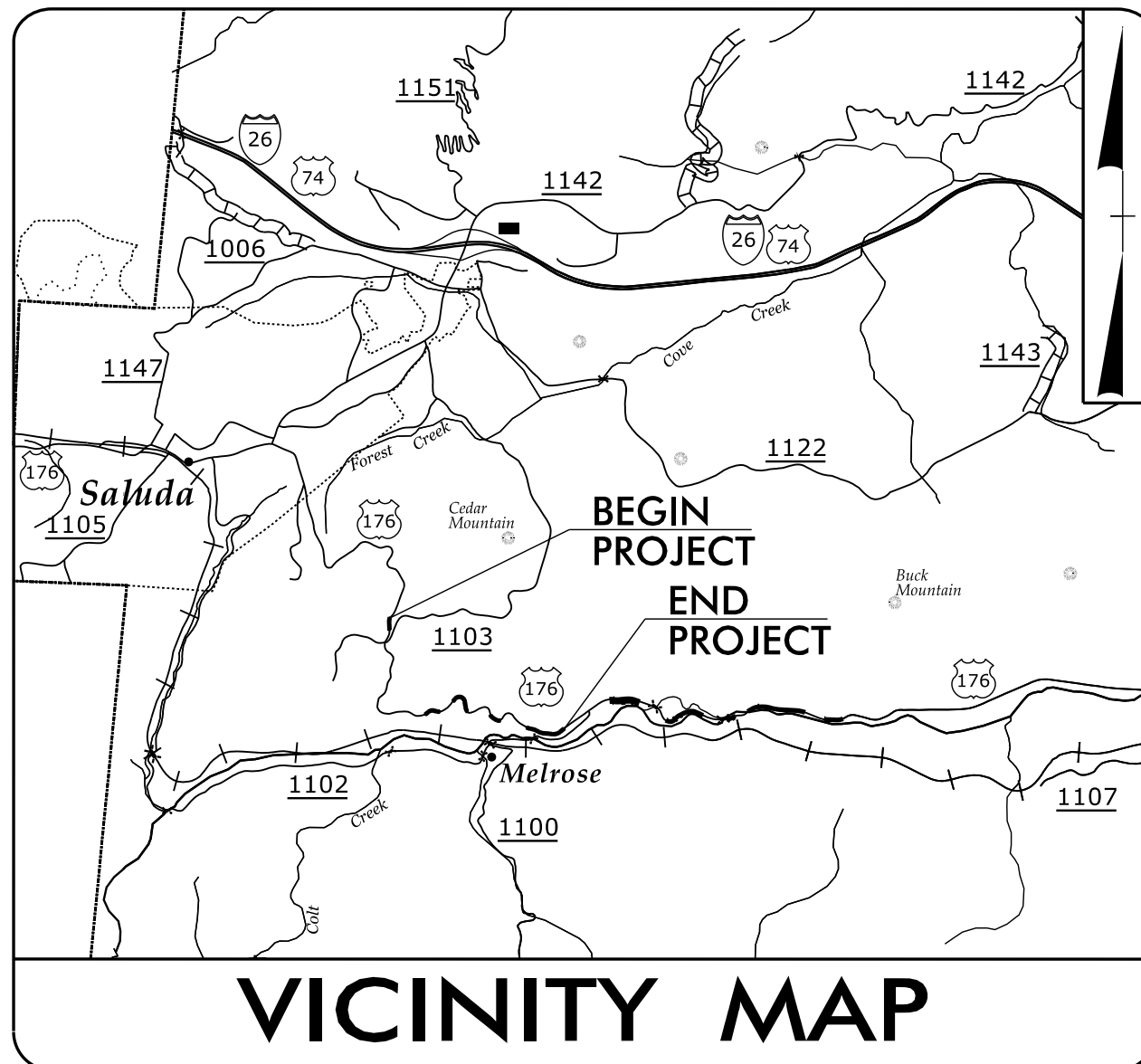

STATE OF NORTH CAROLINA
DIVISION OF HIGHWAYS

POLK COUNTY

LOCATION: US 176

TYPE OF WORK: GRADING, DRAINAGE, PAVING, AND RETAINING WALLS

STATE	STATE PROJECT REFERENCE NO.	SHEET NO.	TOTAL SHEETS
N.C.	W03293	1	
STATE PROJ. NO.	DESCRIPTION		
18314.1075023	314		
18314.1075025	316		
18314.1075026	317		
18314.1075027	318		
18314.1075028	319		
18314.1075029	320		
18314.1075030	321		

PART I

BEGIN PROJECT W03293
-L316- STA. 10 + 85.00
BEGIN CONSTRUCTION (SITE 316)

END CONSTRUCTION
-L316- STA. 13 + 50.00
(Site 316)

BEGIN CONSTRUCTION
-L317- STA. 14 + 40.00
(Sites 317 & 318)

END CONSTRUCTION
-L317- STA. 16 + 50.00
(Sites 317 & 318)

END CONSTRUCTION
-L314- STA. 16 + 00.00
(Site 314)

BEGIN CONSTRUCTION
-L319 STA. 9 + 50.00
(Site 319)

BEGIN CONSTRUCTION
-L314- STA. 11 + 10.00
(Site 314)

END PROJECT W03293
-L320- STA. 20 + 50.00
END CONSTRUCTION (SITES 320 & 321)

END CONSTRUCTION
-L319 STA. 17 + 30.00
(Site 319)

BEGIN CONSTRUCTION
-L320- STA. 12 + 00.00
(Sites 320 & 321)

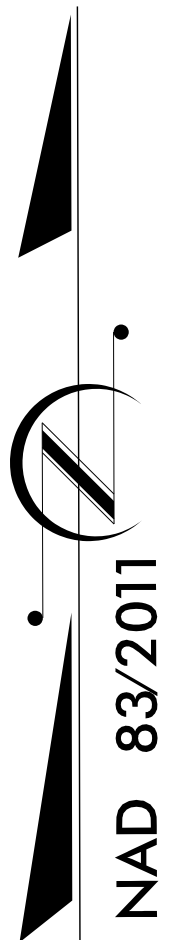

DOCUMENT NOT CONSIDERED FINAL
UNLESS ALL SIGNATURES COMPLETED

GRAPHIC SCALES

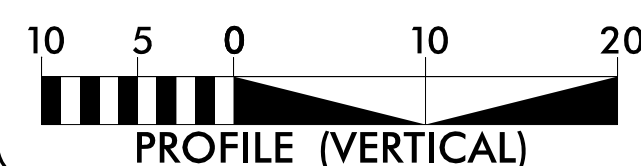
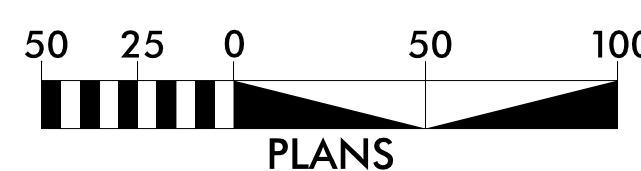

DESIGN DATA

ADT 2025 = 1,230
ADT 2050 = 1,570
V = 60 MPH

FUNC CLASS =
MAJOR COLLECTOR
SUBREGIONAL

PROJECT LENGTH

LENGTH ROADWAY SITE 314 = 0.093 MILES
LENGTH ROADWAY SITE 316 = 0.050 MILES
LENGTH ROADWAY SITE 318 = 0.040 MILES
LENGTH ROADWAY SITE 319 = 0.148 MILES
LENGTH ROADWAY SITE 320 = 0.085 MILES
LENGTH ROADWAY SITE 321 = 0.076 MILES

TOTAL LENGTH ROADWAY PROJECT W03293 = 0.492

NCDOT CONTACT: JEANETTE WHITE, PE

PLANS PREPARED BY:
TGS ENGINEERS
201 W. MARION ST., STE 200
SHELBY, NC 28150
PH (704) 476-0003
CORP. LICENSE NO.: C-0275

PLANS PREPARED FOR:
NORTH CAROLINA DEPARTMENT OF TRANSPORTATION
DIVISION 14
252 Webster Rd
Sylva, NC 28779

RIGHT OF WAY DATE:
AUGUST 29, 2025

JIMMY L. TERRY, PE
PROJECT ENGINEER

LETTING DATE:
JULY 21, 2026

AUSTIN R. TURNER, PE
PROJECT DESIGN ENGINEER

2024 STANDARD SPECIFICATIONS

HYDRAULICS ENGINEER

5/21/2026

Signed by:
John W. Twissdale, Jr. P.E.

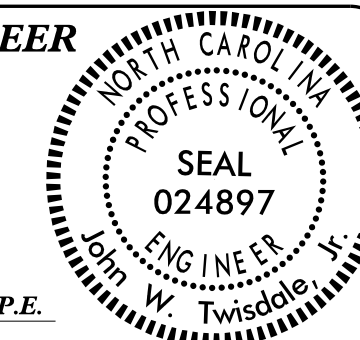

ROADWAY DESIGN ENGINEER

5/21/2026

Signed by:
Jimmy L. Terry P.E.

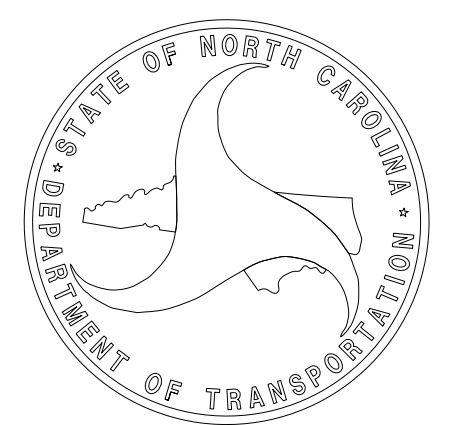
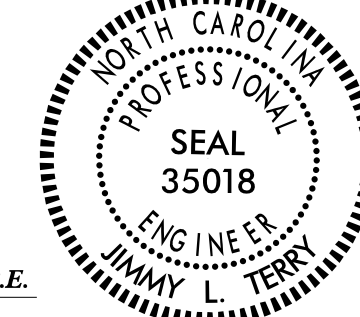

FINAL PAVEMENT SCHEDULE

(Nov 11, 2025)

C1	PROP. APPROX. 3" ASPHALT CONCRETE SURFACE COURSE, TYPE S9.5C, AT AN AVERAGE RATE OF 168 LBS. PER SQ. YD. IN EACH OF TWO LAYERS.
C2	PROP. APPROX. 1 1/2" ASPHALT CONCRETE SURFACE COURSE, TYPE S9.5C, AT AN AVERAGE RATE OF 168 LBS. PER SQ. YD.
E1	PROP. APPROX. 5" ASPHALT CONCRETE BASE COURSE, TYPE B25.0C, AT AN AVERAGE RATE OF 570 LBS. PER SQ. YD.
R1	SHOULDER BERM GUTTER
T	EARTH MATERIAL.
U	EXISTING PAVEMENT
V1	MILLING BITUMINOUS PAVEMENT, 1 1/2" DEPTH

PAVEMENT EDGE SLOPES ARE 1:1 UNLESS SHOWN OTHERWISE.

NOTE:

DUE TO UNKNOWN DAMAGE TO THE EXISTING PAVEMENT STRUCTURE FROM HELENE, FULL DEPTH PAVEMENT IS SHOWN TO EXTEND FOR THE FULL LENGTH OF AREAS COVERED BY TYPICAL SECTIONS NO. 2, 3, 4 AND 5. IF AGREED UPON BY THE RESIDENT ENGINEER AND CONTRACTOR DURING CONSTRUCTION TO OVERLAY EXISTING PAVEMENT ONLY, STANDARD NCDOT MILLING AND RESURFACING/WEDGING METHODS SHALL APPLY. THE ENGINEER OF RECORD SHALL BE NOTIFIED OF CHANGES, AND STANDARD DETAILS CAN BE PROVIDED UPON REQUEST.

PROJECT REFERENCE NO. W03293	SHEET NO. 2A-1
ROADWAY DESIGN ENGINEER JIMMY L. TERRY 35018 5/21/2026	PAVEMENT DESIGN ENGINEER JIMMY L. TERRY 045542 5/21/2026
DOCUMENT NOT CONSIDERED FINAL UNLESS ALL SIGNATURES COMPLETED	
TGS ENGINEERS 201 W. MARION ST. STE 200 SHELBY, NC 28150 PH (704) 476-0003 CORP. LICENSE NO.: C-0275	

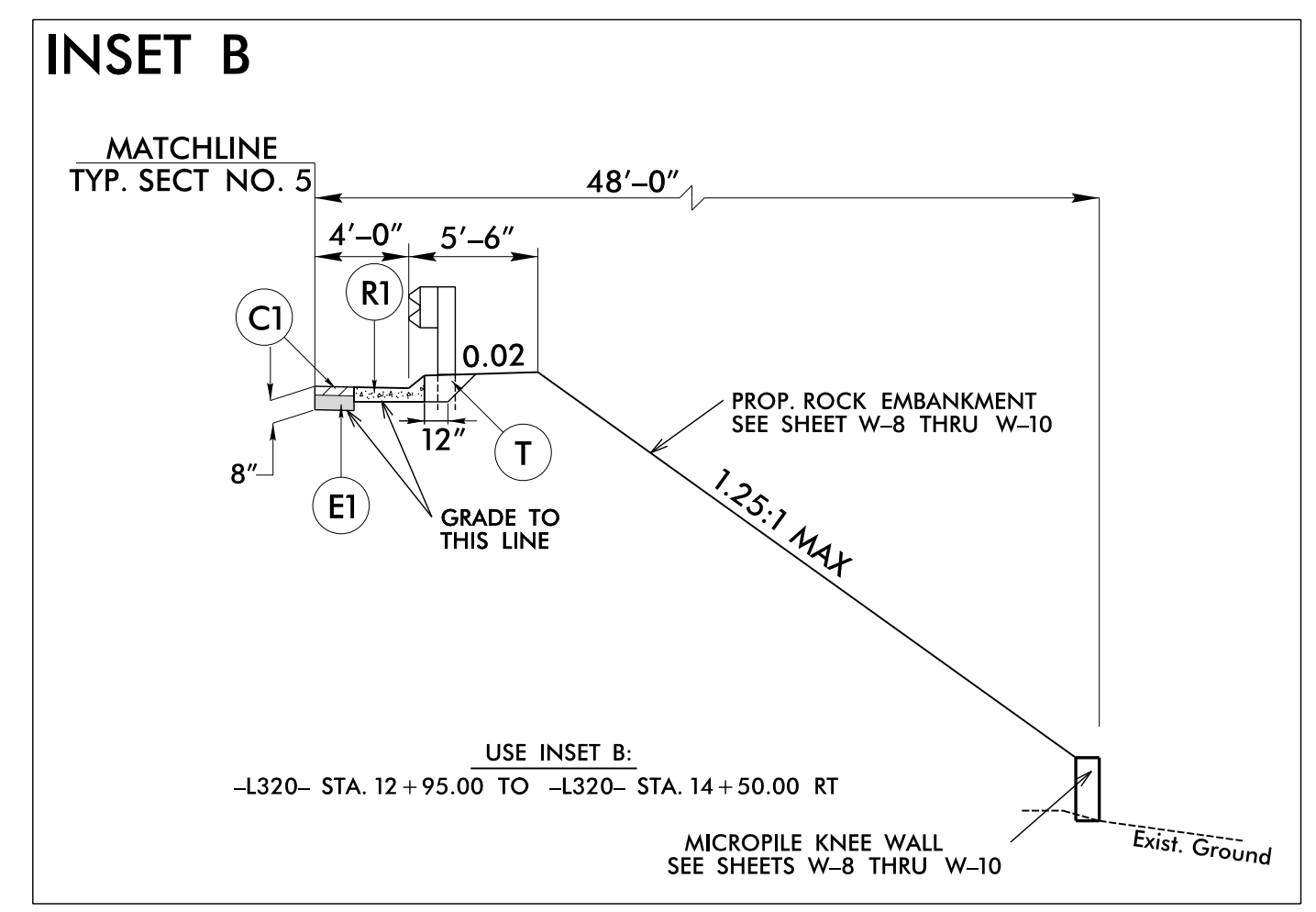
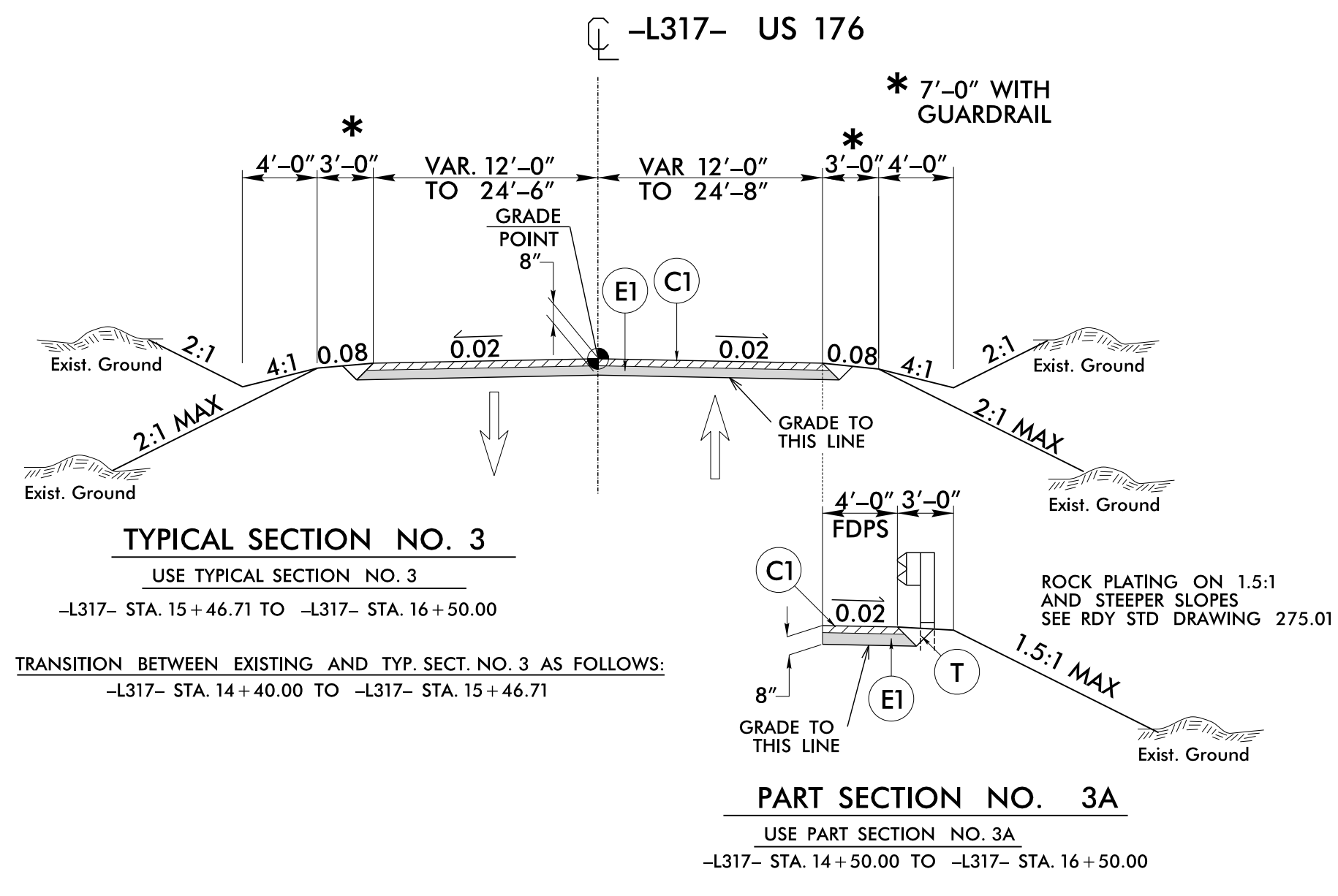
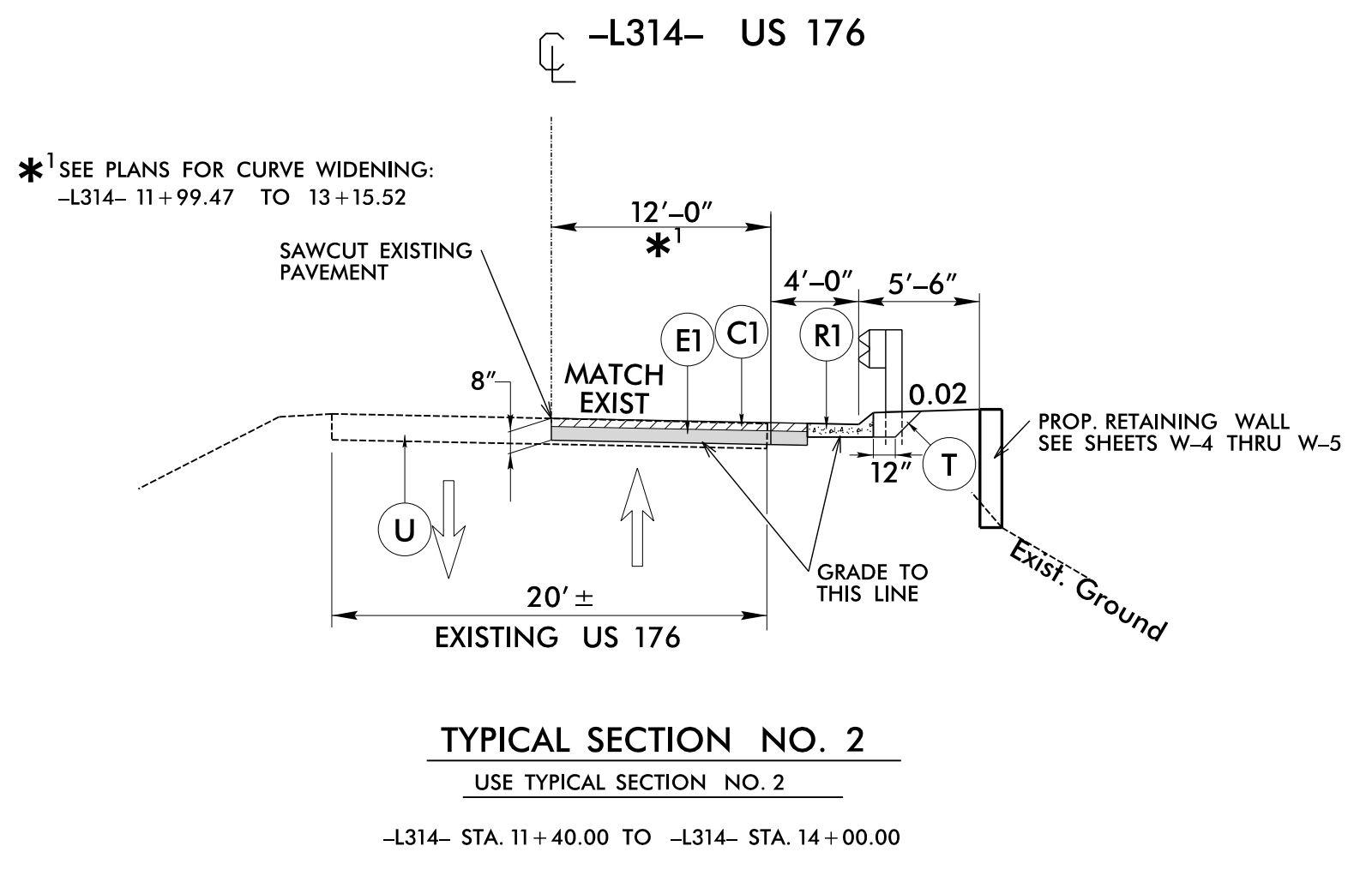
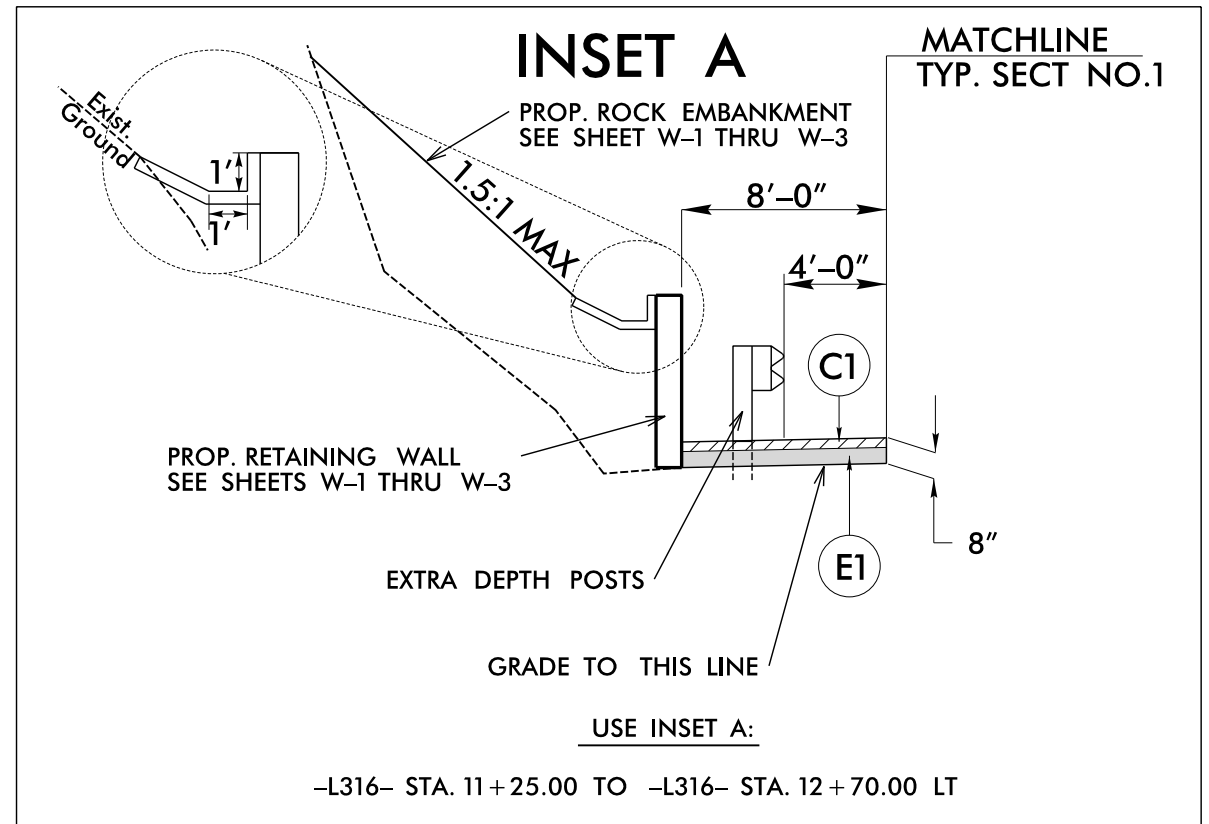
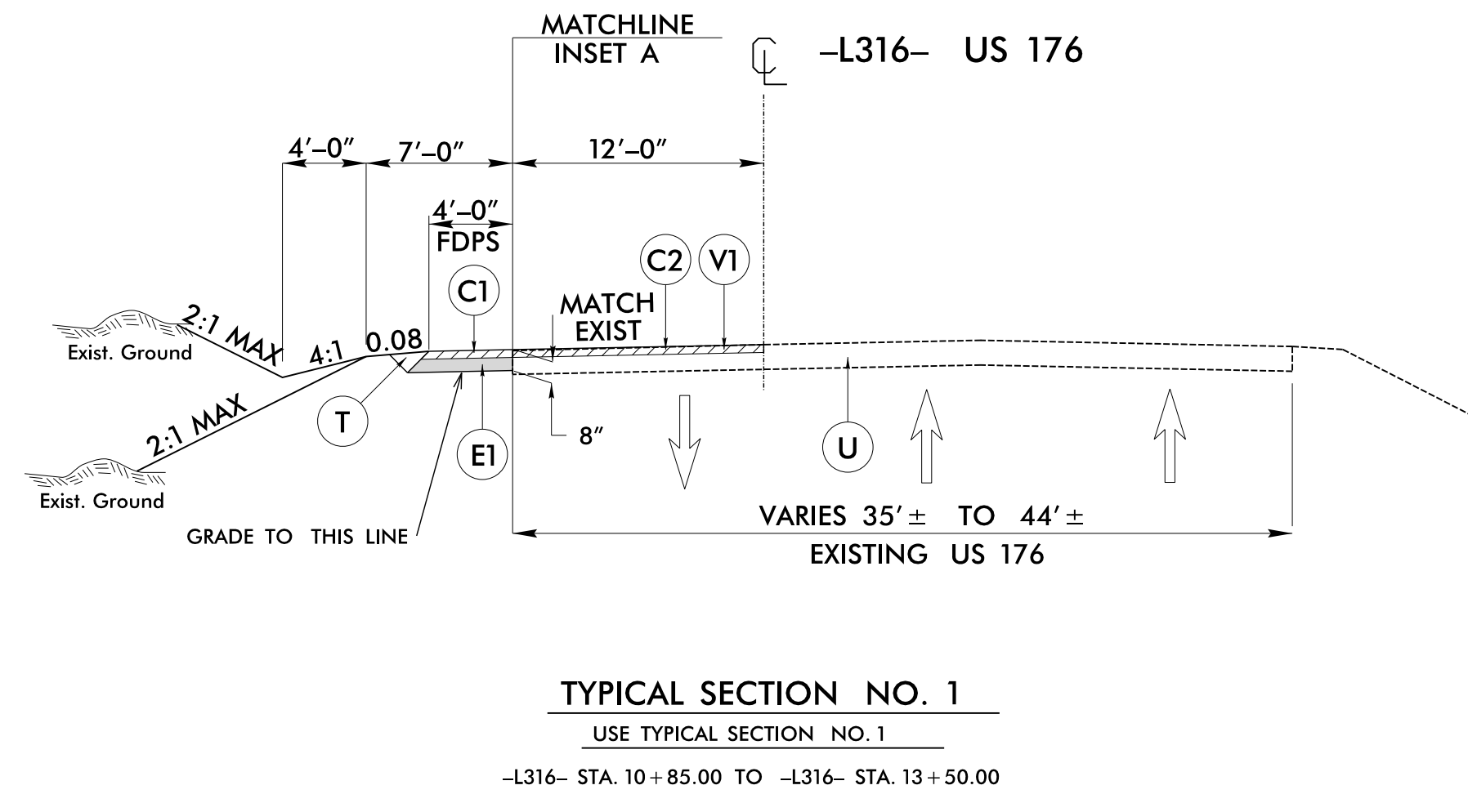

TRANSITION BETWEEN EXISTING AND TYP. SECT. NO. 2 AS FOLLOWS:
 -L314- STA. 11+10.00 TO -L314- STA. 11+40.00
 -L314- STA. 14+00.00 TO -L314- STA. 14+50.00

TRANSITION BETWEEN EXISTING AND TYP. SECT. NO. 3 AS FOLLOWS:
 -L317- STA. 14+40.00 TO -L317- STA. 15+46.71

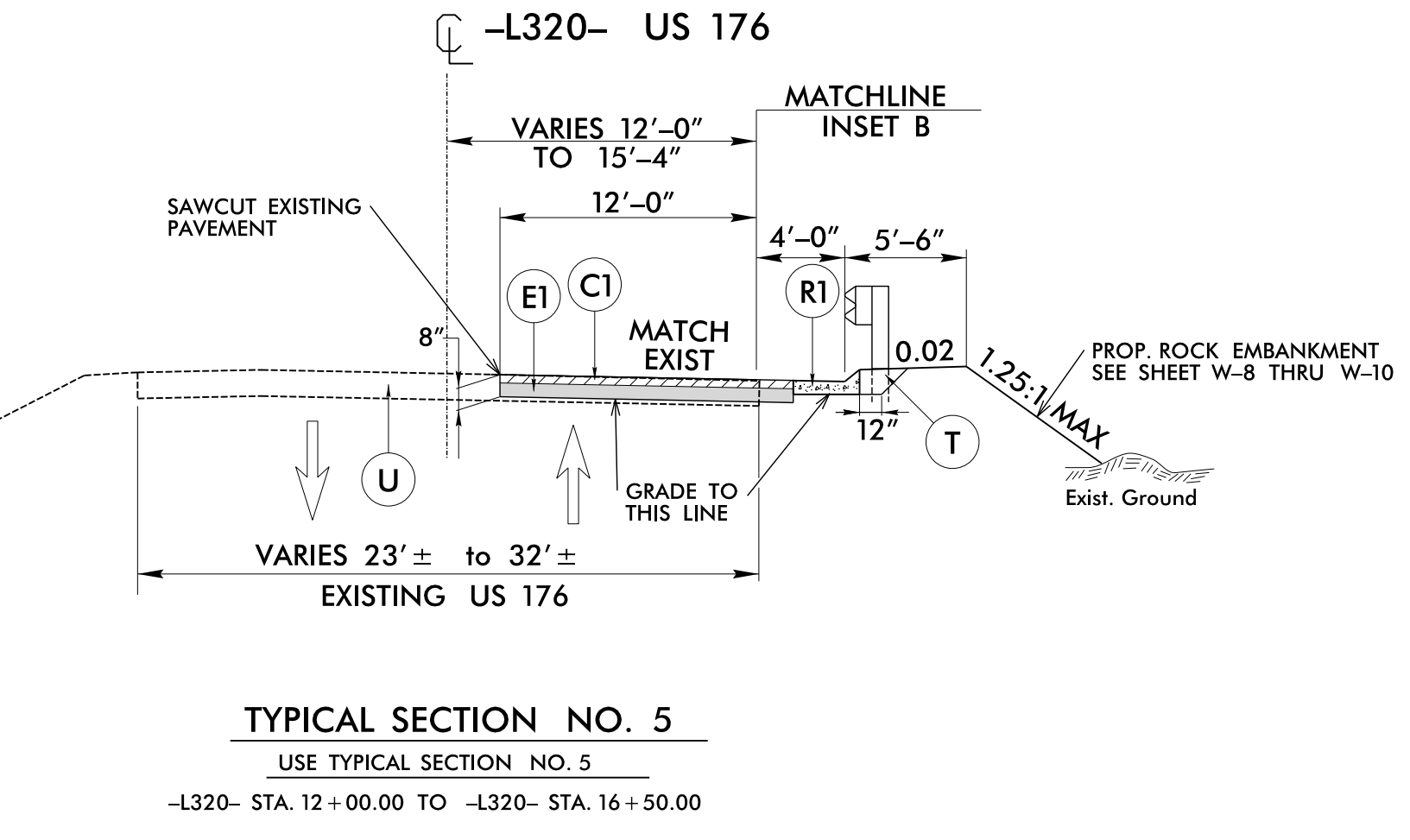
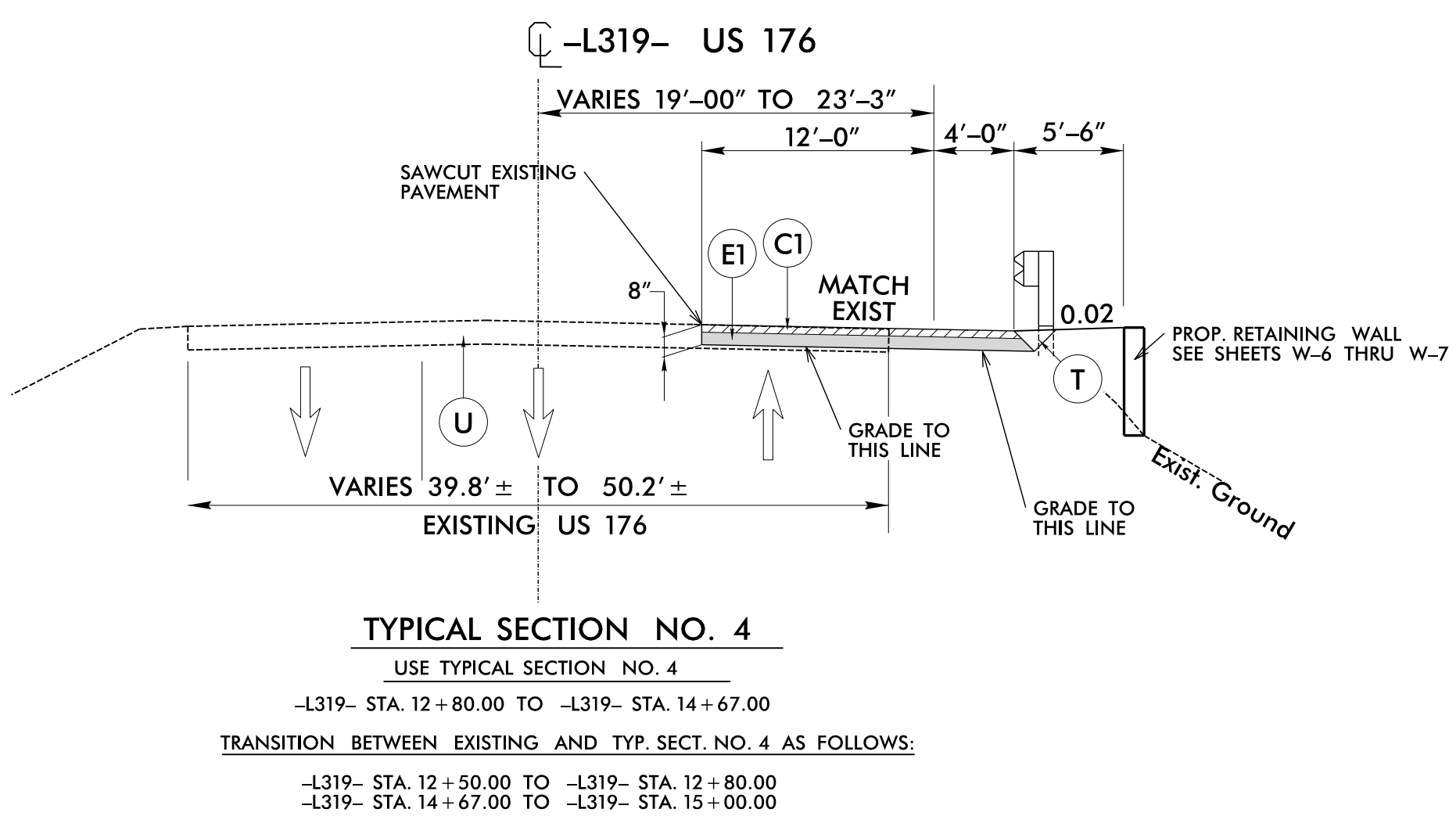

TRANSITION BETWEEN EXISTING AND TYP. SECT. NO. 4 AS FOLLOWS:
 -L319- STA. 12+50.00 TO -L319- STA. 12+80.00
 -L319- STA. 14+67.00 TO -L319- STA. 15+00.00

TRANSITION BETWEEN TYP. SECT. NO. 5 AND TYP. SECT. NO. 6 AS FOLLOWS:
 -L320- STA. 16+50.00 TO -L320- STA. 17+00.00

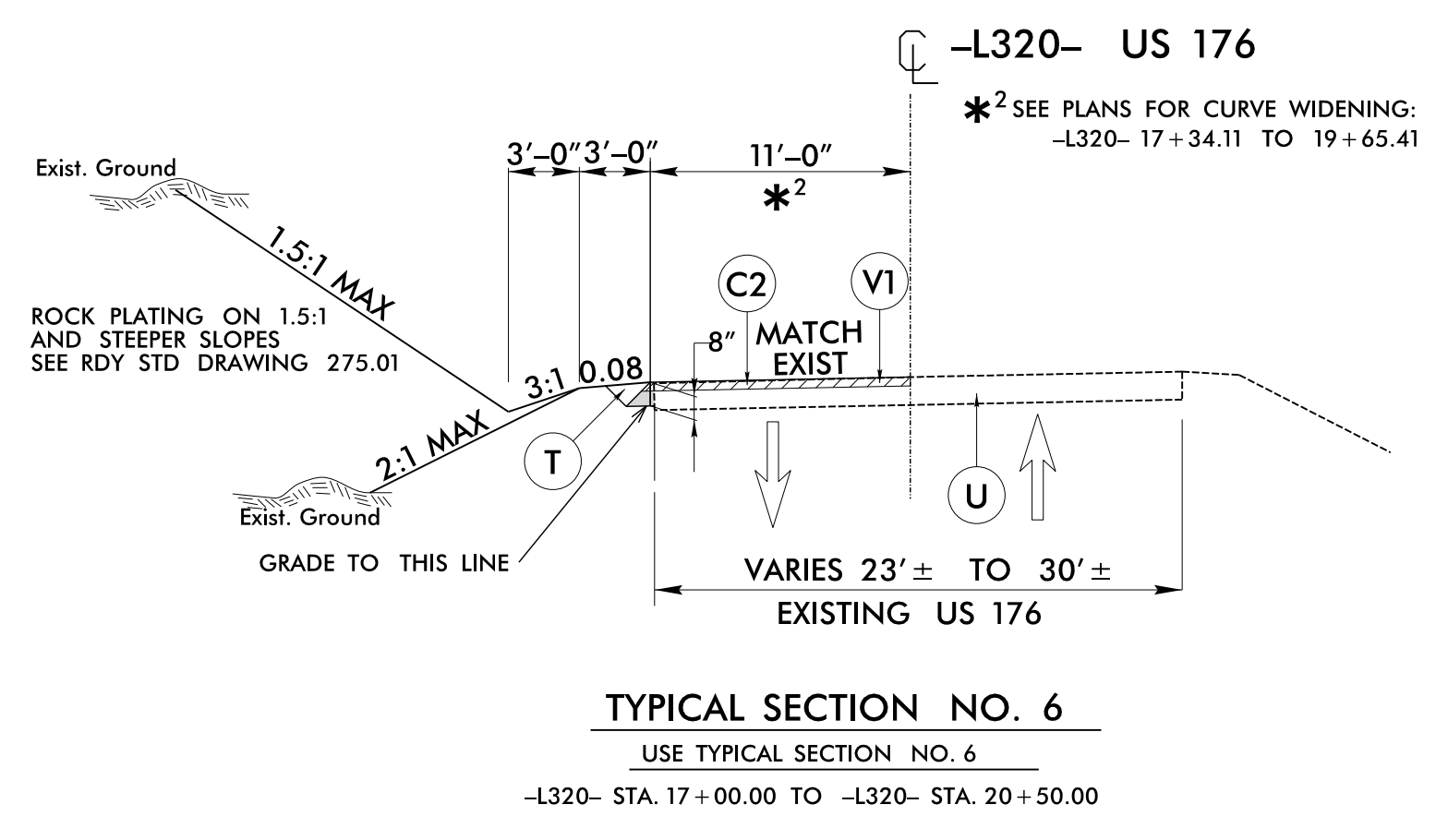

*2 SEE PLANS FOR CURVE WIDENING:
 -L320- 17+34.11 TO 19+65.41

5/28/2026
 C:\Users\jerry\OneDrive\Documents\Roadway\Design\Title_Typicals_Details_Summary\US176_Rdy_3000_typ.dgn
 User: jerry

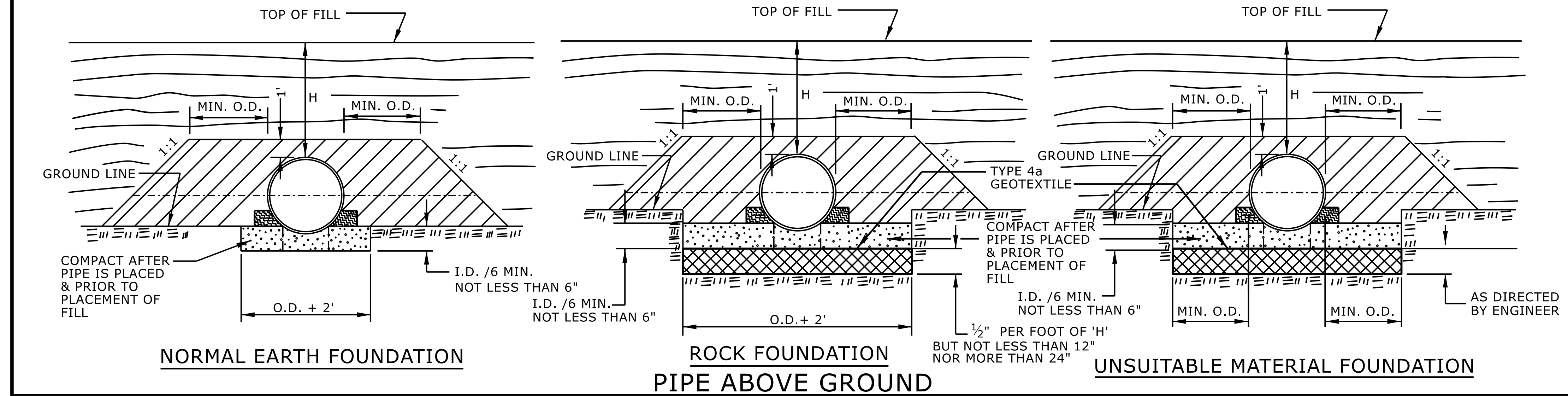
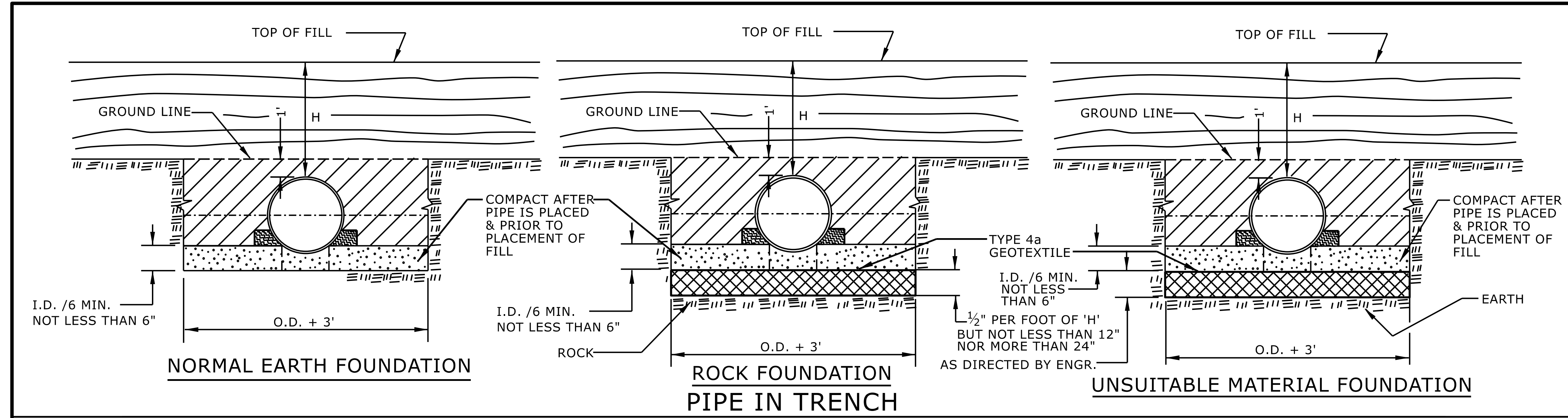

GENERAL NOTES:
 I.D. = THE MAXIMUM HORIZONTAL INSIDE DIAMETER DIMENSION.
 O.D. = THE MAXIMUM HORIZONTAL OUTSIDE DIAMETER DIMENSION.
 H = THE FILL HEIGHT MEASURED VERTICALLY AT ANY POINT ALONG THE PIPE FROM THE TOP OF THE PIPE TO THE TOP OF THE EMBANKMENT AT THAT POINT.

APPROVED SUITABLE LOCAL MATERIAL.
 TAKE CARE TO FULLY COMPACT HAUNCH ZONE OF PIPE BACKFILL.
 LOOSELY PLACED SELECT MATERIAL CLASS III OR CLASS II, TYPE 1 FOR PIPE BEDDING. LEAVE SECTION DIRECTLY BENEATH PIPE UNCOMPACTED AS PIPE SEATING AND BACKFILL WILL ACCOMPLISH COMPACTION.

DO NOT OPERATE HEAVY EQUIPMENT OVER ANY PIPE CULVERT UNTIL THE PIPE CULVERT HAS BEEN PROPERLY BACKFILLED AND COVERED WITH AT LEAST 3 FEET OF APPROVED MATERIAL.

REFER TO NCDOT PIPE MATERIAL SELECTION GUIDE AND STANDARD SPECIFICATIONS FOR ALLOWABLE PIPE FILL HEIGHTS AND PIPE SPECIFICATIONS.

SPRINGLINE OF PIPE
 SELECT BACKFILL MATERIAL CLASS III OR CLASS II, TYPE 1 ABOVE AND BELOW SPRINGLINE.
 UNDISTURBED EARTH MATERIAL
 SELECT MATERIAL CLASS V OR VI FOR FOUNDATION CONDITIONING. ENCAPSULATE WITH TYPE IV GEOTEXTILE AS DIRECTED BY THE ENGINEER.

STATE OF NORTH CAROLINA
 DEPT. OF TRANSPORTATION
 DIVISION OF HIGHWAYS
 RALEIGH, N.C.

ROADWAY DETAIL DRAWING FOR
METHOD OF PIPE INSTALLATION
 FLEXIBLE PIPE

SHEET 1 OF 2
300.01

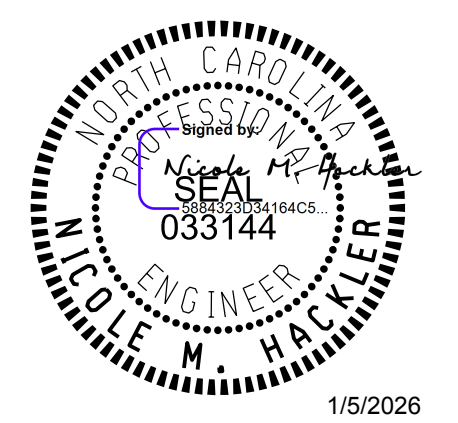

DOCUMENT NOT CONSIDERED FINAL
UNLESS ALL SIGNATURES COMPLETED



CONTRACTS STANDARDS AND DEVELOPMENT UNIT
 Office 919-707-6950 FAX 919-250-4119

SEE TITLE BLOCK

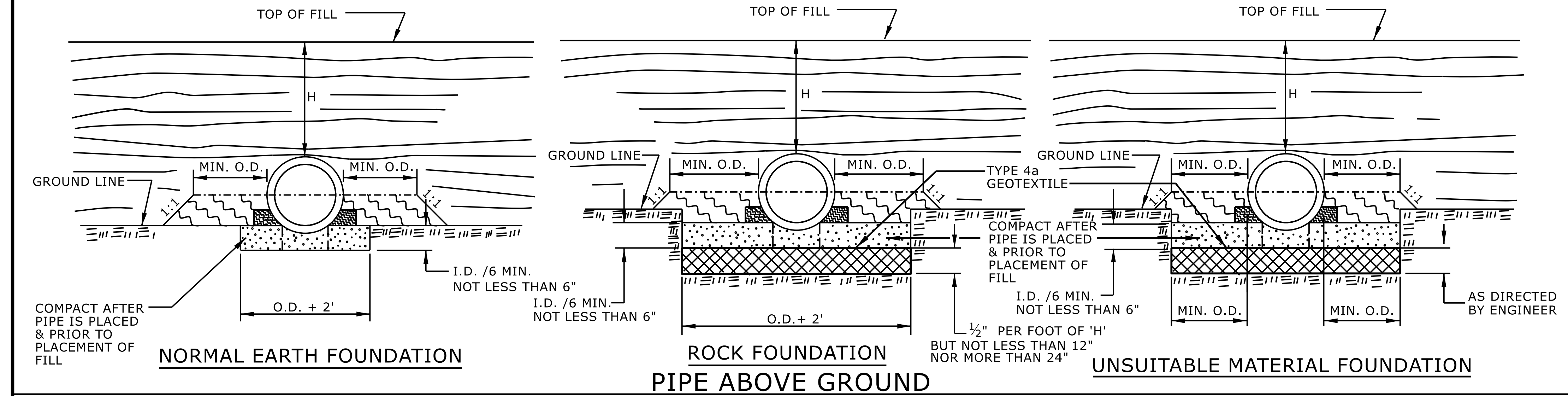
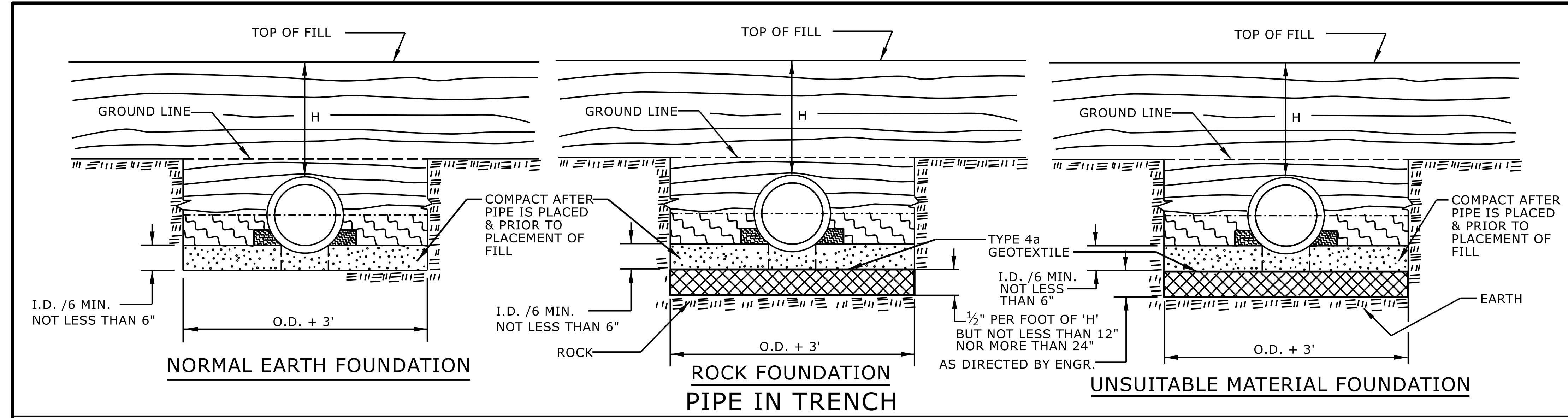
ORIGINAL BY: S.CALHOUN DATE: 7-25-2024
 MODIFIED BY: _____ DATE: _____
 CHECKED BY: _____ DATE: _____
 FILE SPEC.: _____





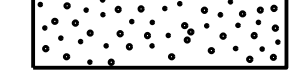

GENERAL NOTES:
 I.D. = THE MAXIMUM HORIZONTAL INSIDE DIAMETER DIMENSION.
 O.D. = THE MAXIMUM HORIZONTAL OUTSIDE DIAMETER DIMENSION.
 H = THE FILL HEIGHT MEASURED VERTICALLY AT ANY POINT ALONG THE PIPE FROM THE TOP OF THE PIPE TO THE TOP OF THE EMBANKMENT AT THAT POINT.

-  APPROVED SUITABLE LOCAL MATERIAL.
-  TAKE CARE TO FULLY COMPACT HAUNCH ZONE OF PIPE BACKFILL.
-  LOOSELY PLACED SELECT MATERIAL CLASS III OR CLASS II, TYPE 1 FOR PIPE BEDDING. LEAVE SECTION DIRECTLY BENEATH PIPE UNCOMPACTED AS PIPE SEATING AND BACKFILL WILL ACCOMPLISH COMPACTION.

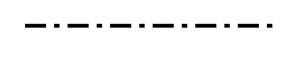
DO NOT OPERATE HEAVY EQUIPMENT OVER ANY PIPE CULVERT UNTIL THE PIPE CULVERT HAS BEEN PROPERLY BACKFILLED AND COVERED WITH AT LEAST 3 FEET OF APPROVED MATERIAL.

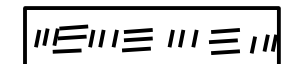
REFER TO NCDOT PIPE MATERIAL SELECTION GUIDE AND STANDARD SPECIFICATIONS FOR ALLOWABLE PIPE FILL HEIGHTS AND PIPE SPECIFICATIONS.

-  SPRINGLINE OF PIPE
-  SELECT BACKFILL MATERIAL CLASS III OR CLASS II, BELOW SPRINGLINE.
-  UNDISTURBED EARTH MATERIAL
-  SELECT MATERIAL CLASS V OR VI FOR FOUNDATION CONDITIONING. ENCAPSULATE WITH TYPE IV GEOTEXTILE AS DIRECTED BY THE ENGINEER.

STATE OF NORTH CAROLINA
 DEPT. OF TRANSPORTATION
 DIVISION OF HIGHWAYS
 RALEIGH, N.C.
 ROADWAY DETAIL DRAWING FOR
METHOD OF PIPE INSTALLATION
 RIGID PIPE

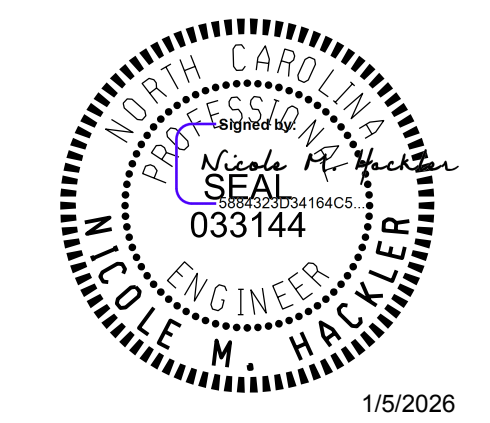

SHEET 2 OF 2
300.01

DOCUMENT NOT CONSIDERED FINAL
 UNLESS ALL SIGNATURES COMPLETED

CONTRACTS STANDARDS AND DEVELOPMENT UNIT
 Office 919-707-6950 FAX 919-250-4119

SEE TITLE BLOCK

ORIGINAL BY: S.CALHOUN DATE: 7-25-2024
 MODIFIED BY: DATE: _____
 CHECKED BY: DATE: _____
 FILE SPEC.: _____

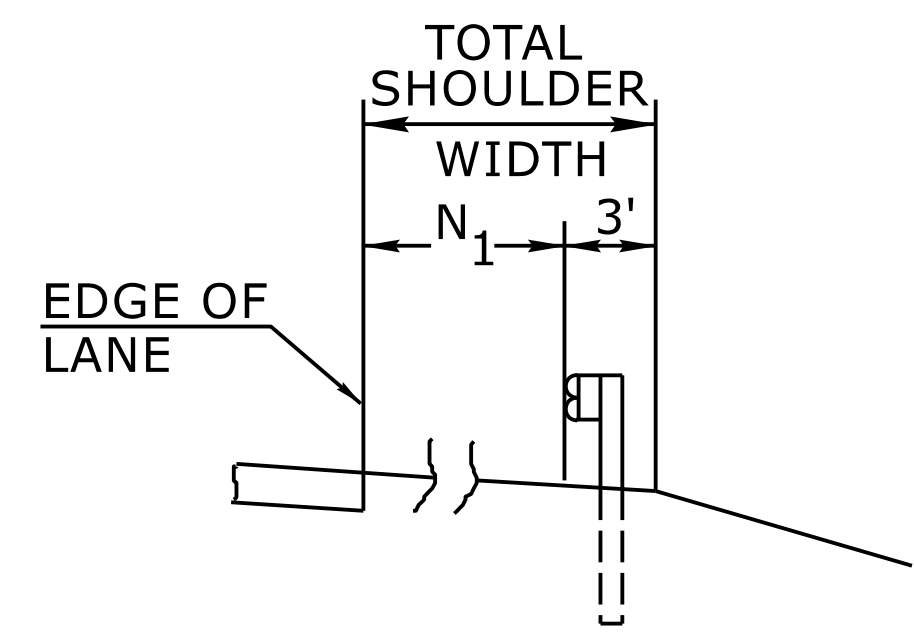

FILL SECTION

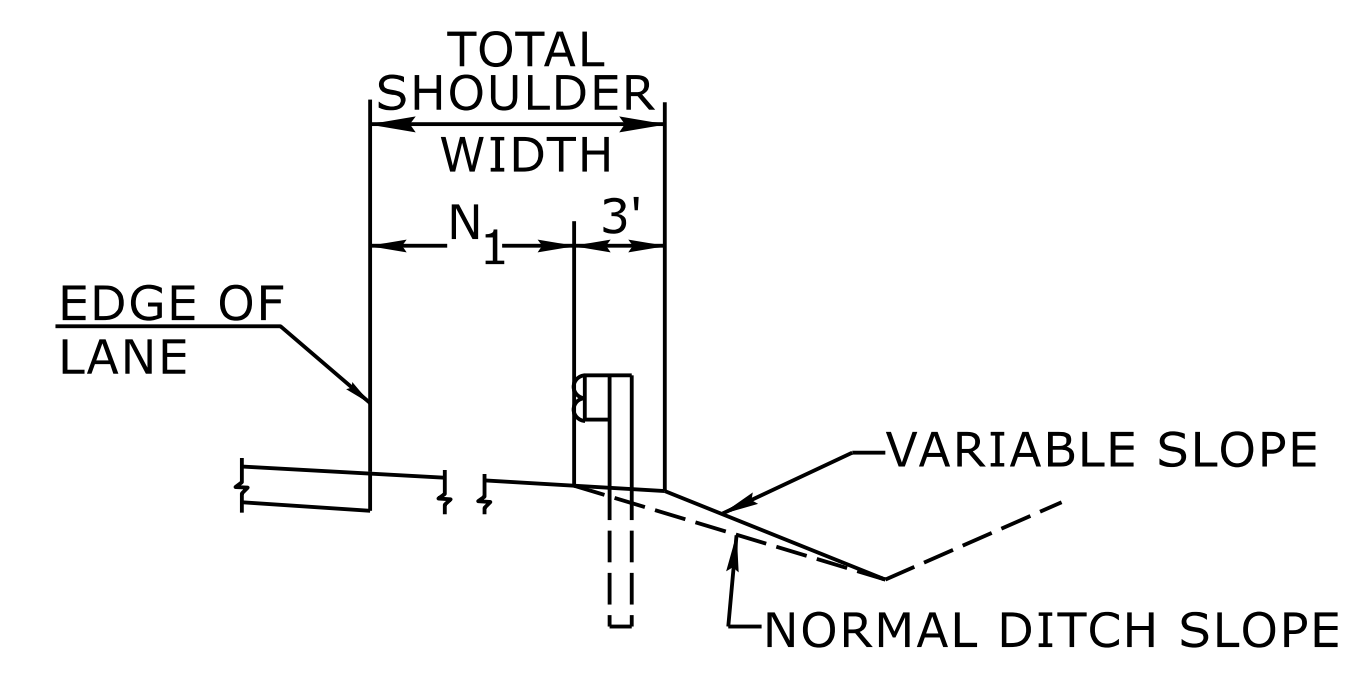

CUT SECTION

"N₁" = DISTANCE FROM EDGE OF LANE TO FACE OF GUARDRAIL WHERE GUARDRAIL IS PARALLEL TO LANE.

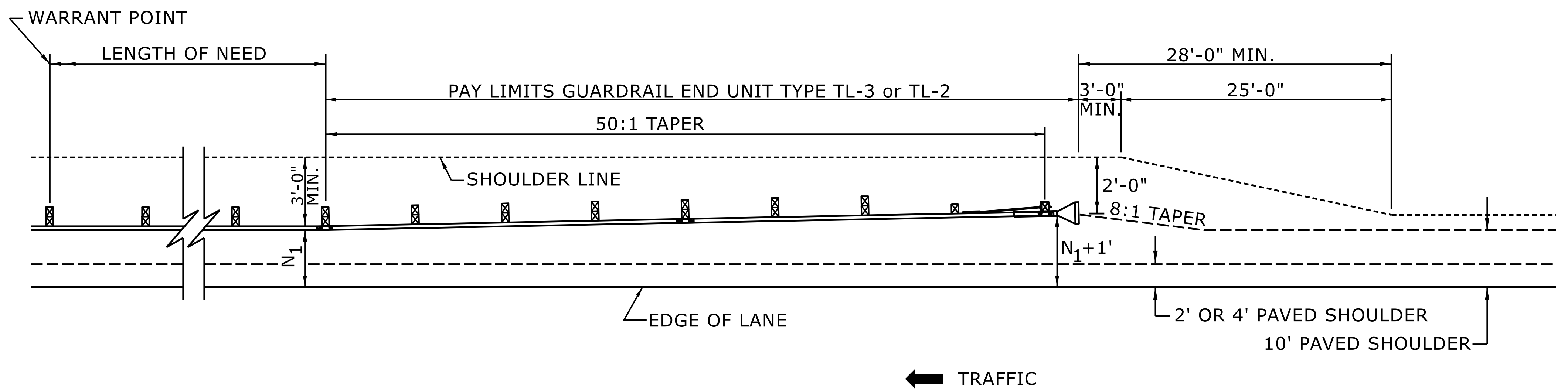

FOR POSTED SPEEDS ≥ 45mph USE GREU TYPE TL-3
FOR POSTED SPEEDS < 45mph USE GREU TYPE TL-2

DETAIL OF BEGINNING OF GUARDRAIL IN CUT OR FILL SECTION

STATE OF
NORTH CAROLINA
DEPT. OF TRANSPORTATION
DIVISION OF HIGHWAYS
RALEIGH, N.C.

ROADWAY DETAIL DRAWING FOR
GUARDRAIL PLACEMENT

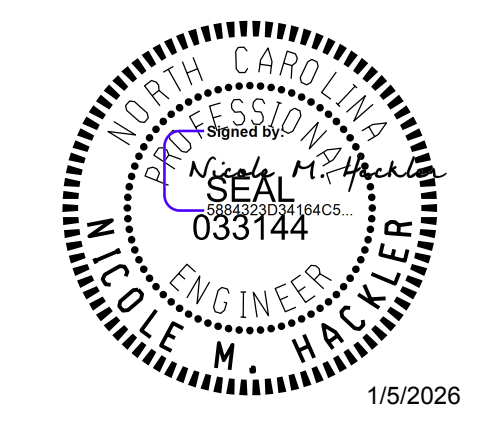

1/5/2026

SHEET 6 OF 15
862D01

DOCUMENT NOT CONSIDERED FINAL
UNLESS ALL SIGNATURES COMPLETED

**CONTRACTS STANDARDS
AND DEVELOPMENT UNIT**
Office 919-707-6950 FAX 919-250-4119

SEE TITLE BLOCK

ORIGINAL BY: S.CALHOUN	DATE: 7-25-2024
MODIFIED BY:	DATE:
CHECKED BY:	DATE:
FILE SPEC.:	

NOTE: IF EXISTING GUARDRAIL IS LOWER THAN 29", USE AN ADDITIONAL 12'-6" LONG SECTION OF GUARDRAIL, FOR EVERY 1" OF HEIGHT DIFFERENCE, TO TRANSITION FROM EXISTING GUARDRAIL TO PROPOSED 31" GUARDRAIL.

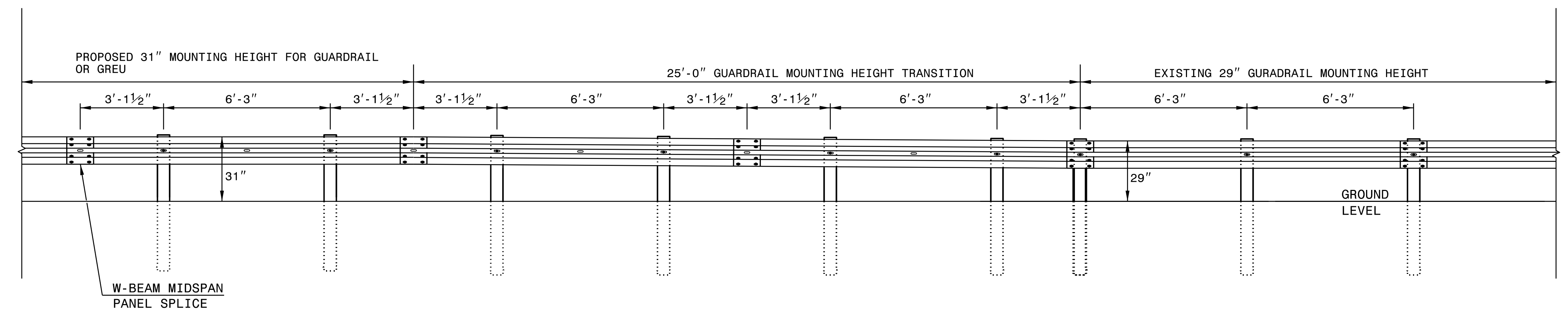

ELEVATION VIEW

TRANSITION FROM 29" TO 31" W-BEAM GUARDRAIL MOUNTING HEIGHT

STATE OF
NORTH CAROLINA
DEPT. OF TRANSPORTATION
DIVISION OF HIGHWAYS
RALEIGH, N.C.

ROADWAY DETAIL DRAWING FOR
GUARDRAIL INSTALLATION

SHEET 5 OF 9
862D02

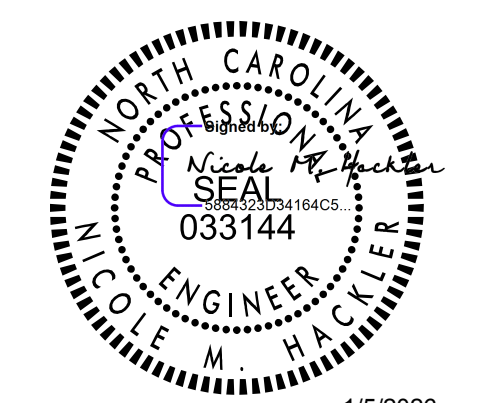

1/5/2026

DOCUMENT NOT CONSIDERED FINAL
UNLESS ALL SIGNATURES COMPLETED

**CONTRACTS STANDARDS
AND DEVELOPMENT UNIT**
Office 919-707-8950 FAX 919-250-4119

SEE TITLE BLOCK

ORIGINAL BY: K. Aldridge	DATE: 02-25
MODIFIED BY:	DATE:
CHECKED BY:	DATE:
FILE SPEC.:	

05-FEB-2025 07:53
U:\spec\of\Details
Revisions\862D02 Detail\862D02.dgn
\$\$\$\$\$USERNAME\$\$\$\$\$

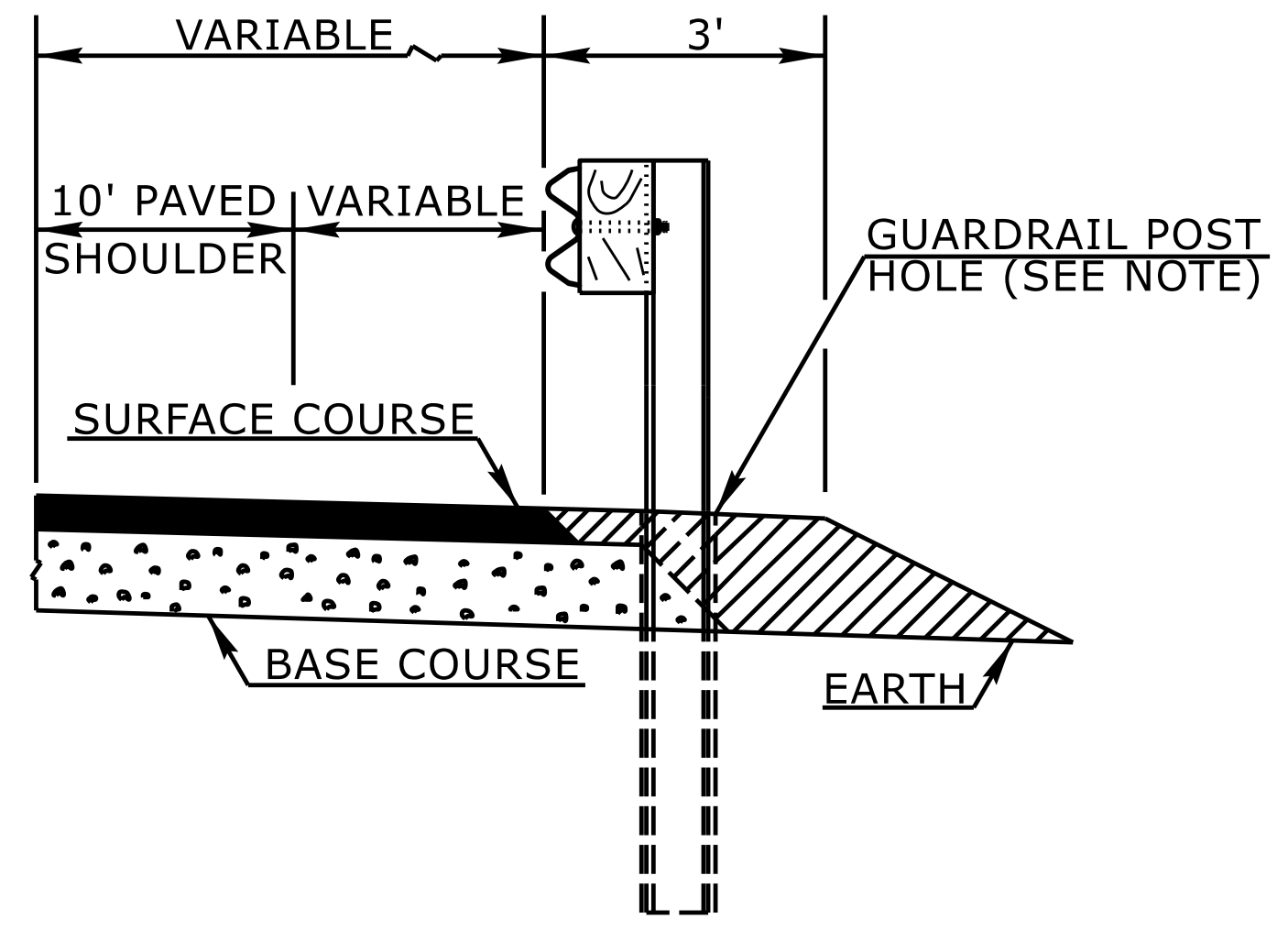

FLEXIBLE PAVED SHOULDER

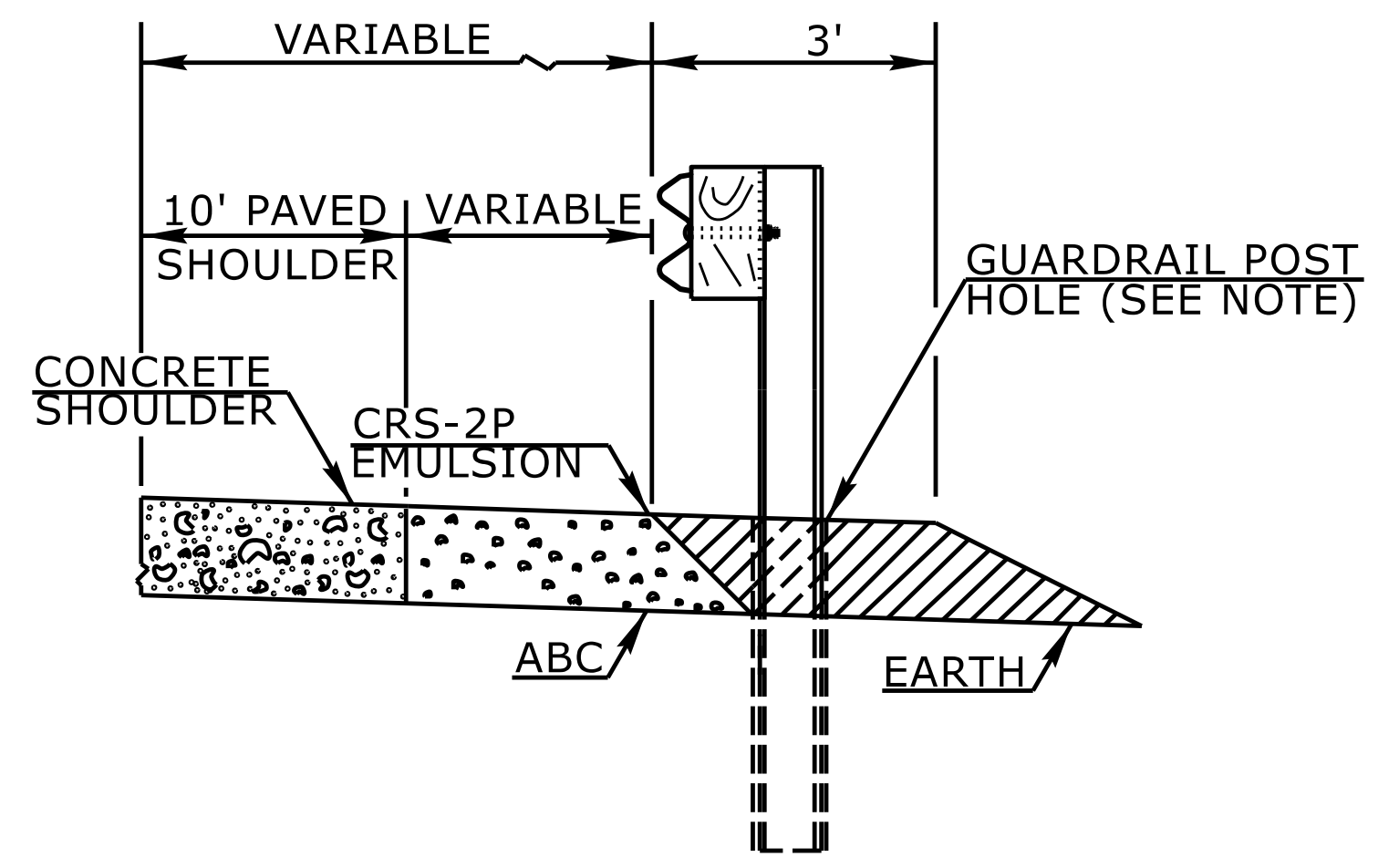

CONCRETE PAVED SHOULDER

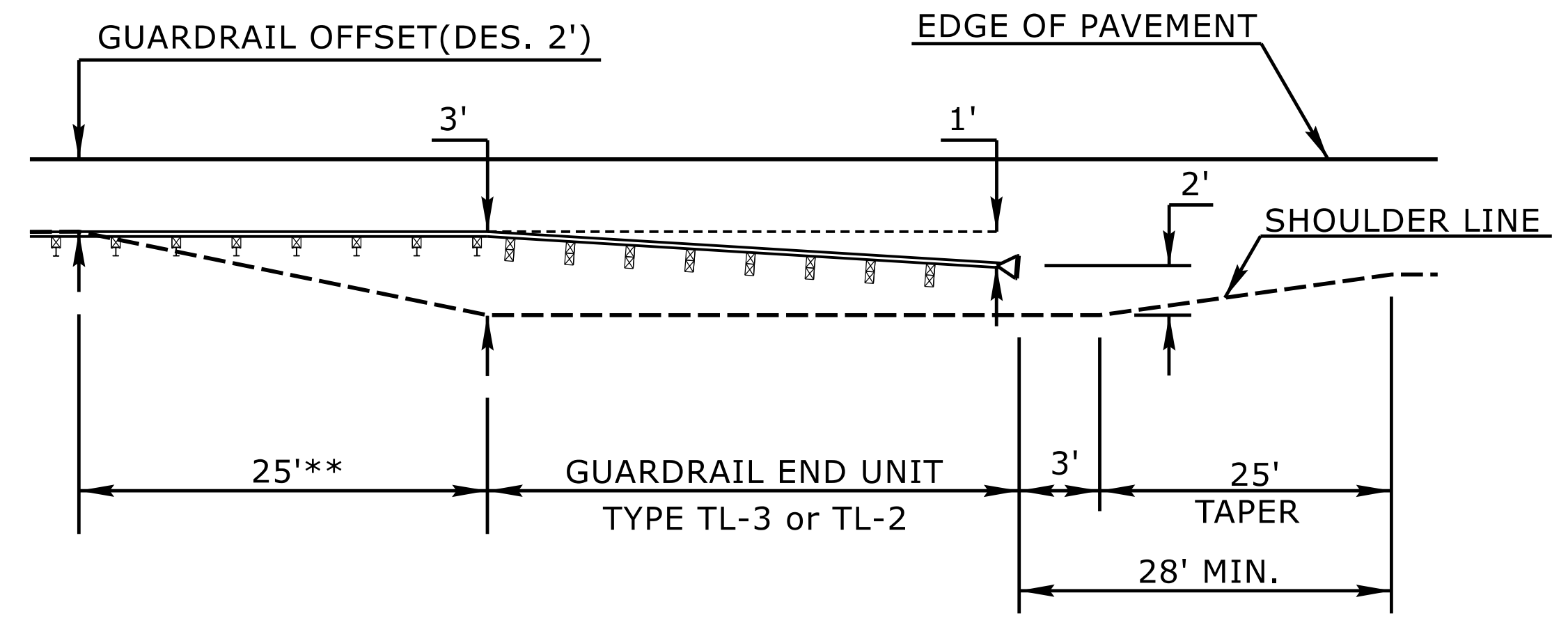

**8' GUARDRAIL POST ON 2:1 SLOPE-END UNIT TRANSITION*
PLAN VIEW**

* THE 8' GUARDRAIL POST ON 2:1 SLOPE DETAIL IS INTENDED FOR USE ONLY IN SEVERELY CONSTRAINED AREAS WITH A POSTED SPEED ≤ 60 MPH. GUARDRAIL END UNITS MAY NOT BE PLACED ON THE 2:1 SLOPE AND MUST TRANSITION TO THE SHOULDER.
 ** 8' GUARDRAIL POST SHOULD BE USED IN THIS RANGE

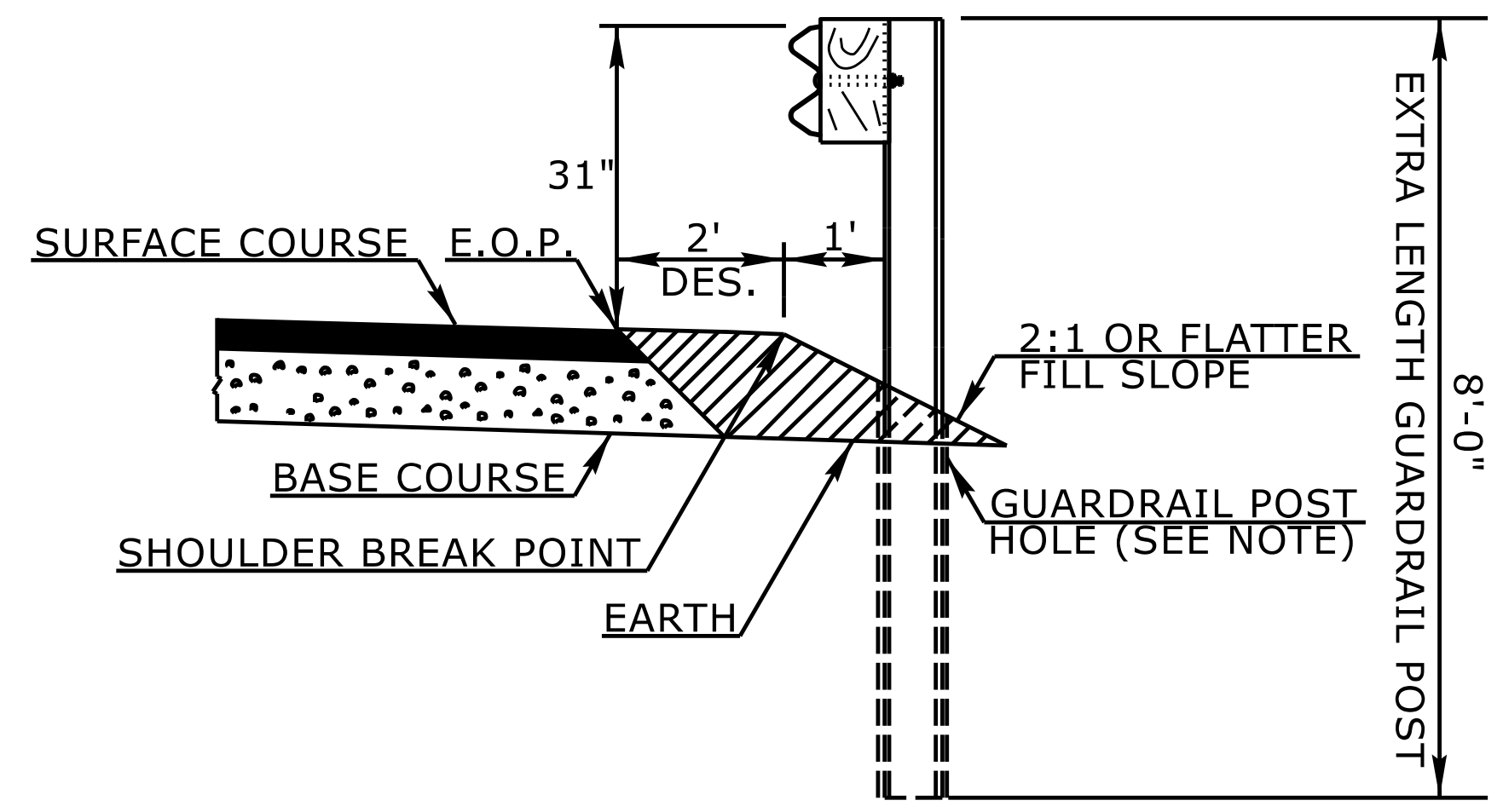

8' GUARDRAIL POST ON 2:1 SLOPE*

NOTE:
 WHEN WOODEN GUARDRAIL POSTS ARE USED, DRILL HOLES THROUGH EARTH MATERIAL AND BASE COURSE. THE POST MAY THEN BE DRIVEN TO THE PROPER DEPTH. DRILL THE HOLE OF SUFFICIENT SIZE TO ACCOMMODATE THE PARTICULAR POST BEING USED. BACKFILL AND TAMP HOLES USING THE EXCAVATED MATERIAL.

STATE OF
 NORTH CAROLINA
 DEPT. OF TRANSPORTATION
 DIVISION OF HIGHWAYS
 RALEIGH, N.C.

ROADWAY DETAIL DRAWING FOR
GUARDRAIL PLACEMENT

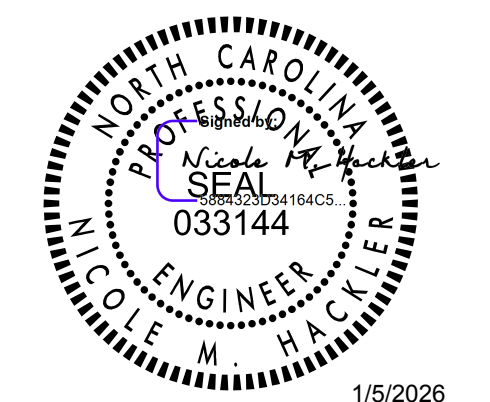

1/5/2026

SHEET 11 OF 15
862D01

DOCUMENT NOT CONSIDERED FINAL
 UNLESS ALL SIGNATURES COMPLETED

**CONTRACTS STANDARDS
 AND DEVELOPMENT UNIT**
 Office 919-707-6950 FAX 919-250-4119

SEE TITLE BLOCK

ORIGINAL BY: L.SMITH DATE: 10-14-2025
 MODIFIED BY: DATE:
 CHECKED BY: DATE:
 FILE SPEC.: DATE:

I3-AUG-2018 09:00 S:\Contracts\Contractors\Special Details\Jhewerton\840d35 TBDI Up to 54in.dgn Jhewerton AT_CSD-292595

STATE OF NORTH CAROLINA
DEPT. OF TRANSPORTATION
DIVISION OF HIGHWAYS
RALEIGH, N.C.

ENGLISH DETAIL DRAWING FOR
TRAFFIC BEARING GRATED INLET
FOR PIPES UP TO 54"

SHEET 1 OF 2
840D35

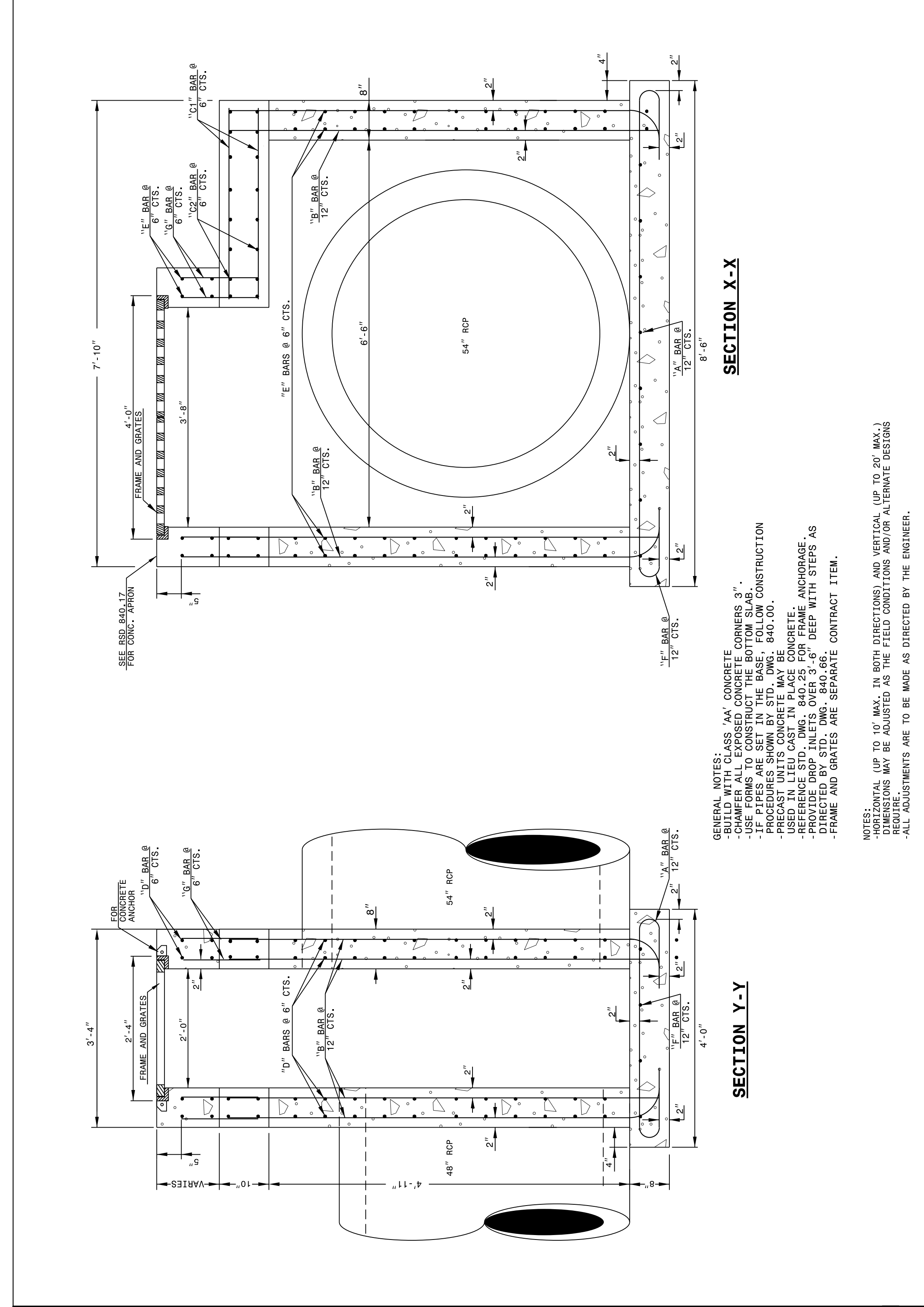

STATE OF NORTH CAROLINA
DEPT. OF TRANSPORTATION
DIVISION OF HIGHWAYS
RALEIGH, N.C.

ENGLISH DETAIL DRAWING FOR
TRAFFIC BEARING GRATED INLET
FOR PIPES UP TO 54"

SHEET 1 OF 2
840D35

STATE OF NORTH CAROLINA
DEPT. OF TRANSPORTATION
DIVISION OF HIGHWAYS
RALEIGH, N.C.

ENGLISH DETAIL DRAWING FOR
TRAFFIC BEARING GRATED INLET
FOR PIPES UP TO 54"

SHEET 2 OF 2
840D35

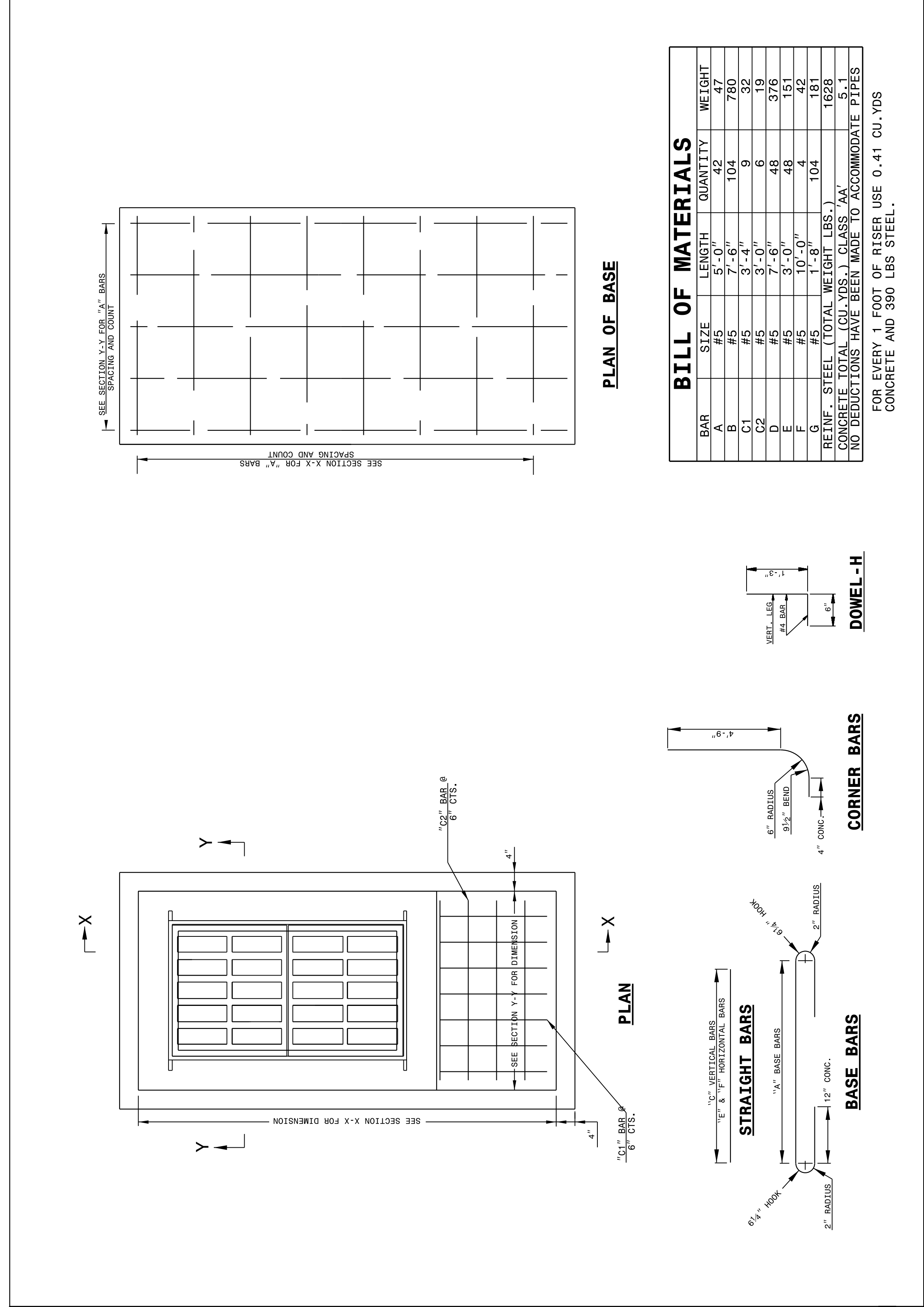

STATE OF NORTH CAROLINA
DEPT. OF TRANSPORTATION
DIVISION OF HIGHWAYS
RALEIGH, N.C.

ENGLISH DETAIL DRAWING FOR
TRAFFIC BEARING GRATED INLET
FOR PIPES UP TO 54"

SHEET 2 OF 2
840D35

SECTION X-X

- GENERAL NOTES:
 -BUILD WITH CLASS 'AA' CONCRETE
 -CHAMFER ALL EXPOSED CONCRETE CORNERS 3".
 -USE FORMS TO CONSTRUCT THE BOTTOM SLAB.
 -PIPE ANCHORS IN THE BASE, FOLLOW CONSTRUCTION PRACTICES SHOWN IN THE BASE, 840.00.
 -PRECAST UNITS CONCRETE MAY BE USED IN LIEU CAST IN PLACE CONCRETE.
 -REFERENCE STD. DWG. 840.25 FOR FRAME ANCHORAGE.
 -FRAME AND GRATES ARE SEPARATE CONTRACT ITEM.
 -FRAME AND GRATES ARE SEPARATE CONTRACT ITEM.

- NOTES:
 -HORIZONTAL UP TO 10' MAX. IN BOTH DIRECTIONS AND VERTICAL (UP TO 20' MAX.) DIMENSIONS MAY BE ADJUSTED AS THE FIELD CONDITIONS AND/OR ALTERNATE DESIGNS REQUIRE.
 -ALL ADJUSTMENTS ARE TO BE MADE AS DIRECTED BY THE ENGINEER.

SECTION Y-Y

BILL OF MATERIALS

BAR	SIZE	LENGTH	QUANTITY	WEIGHT
A	#2	5'-0"	42	47
B	#2	7'-6"	104	790
C1	#3	3'-0"	9	32
C2	#3	3'-0"	6	19
D	#5	3'-6"	48	376
E	#5	3'-0"	48	151
F	#5	1'-0"	4	42
G	#5	1'-0"	104	181
REFIN. STEEL (TOTAL WEIGHT LBS.)				1626
CONCRETE TOTAL (CU. YDS.) CLASS 'AA'				5.1
NO DEDUCTIONS HAVE BEEN MADE TO ACCOMMODATE PIPES				

FOR EVERY 1 FOOT OF RISER USE 0.41 CU. YDS CONCRETE AND 390 LBS STEEL.

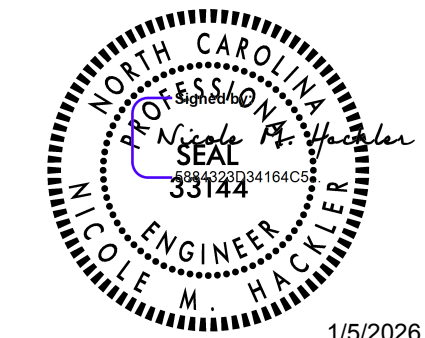

1/5/2026

DOCUMENT NOT CONSIDERED FINAL
UNLESS ALL SIGNATURES COMPLETED

CONTRACT STANDARDS AND DEVELOPMENT UNIT
Office 919-707-6950 FAX 919-250-4119

SEE PLATE FOR TITLE

ORIGINAL BY: K. KEMPF DATE: 03-03-2015
 MODIFIED BY: DATE:
 CHECKED BY: DATE:
 FILE SPEC.: jhewerton/840d35 TBDI Up to 54in.dgn

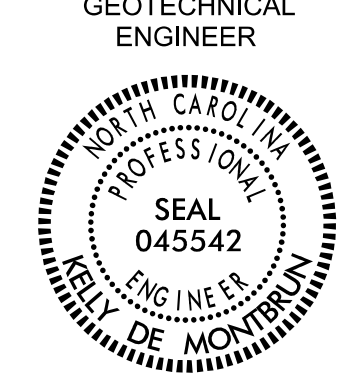
GEOTECHNICAL ENGINEER  Signed by: <i>Kelly de Montigny</i> 12/2/2025 <small>DATE</small>	ENGINEER SIGNATURE _____ DATE _____
DOCUMENT NOT CONSIDERED FINAL UNLESS ALL SIGNATURES COMPLETED	

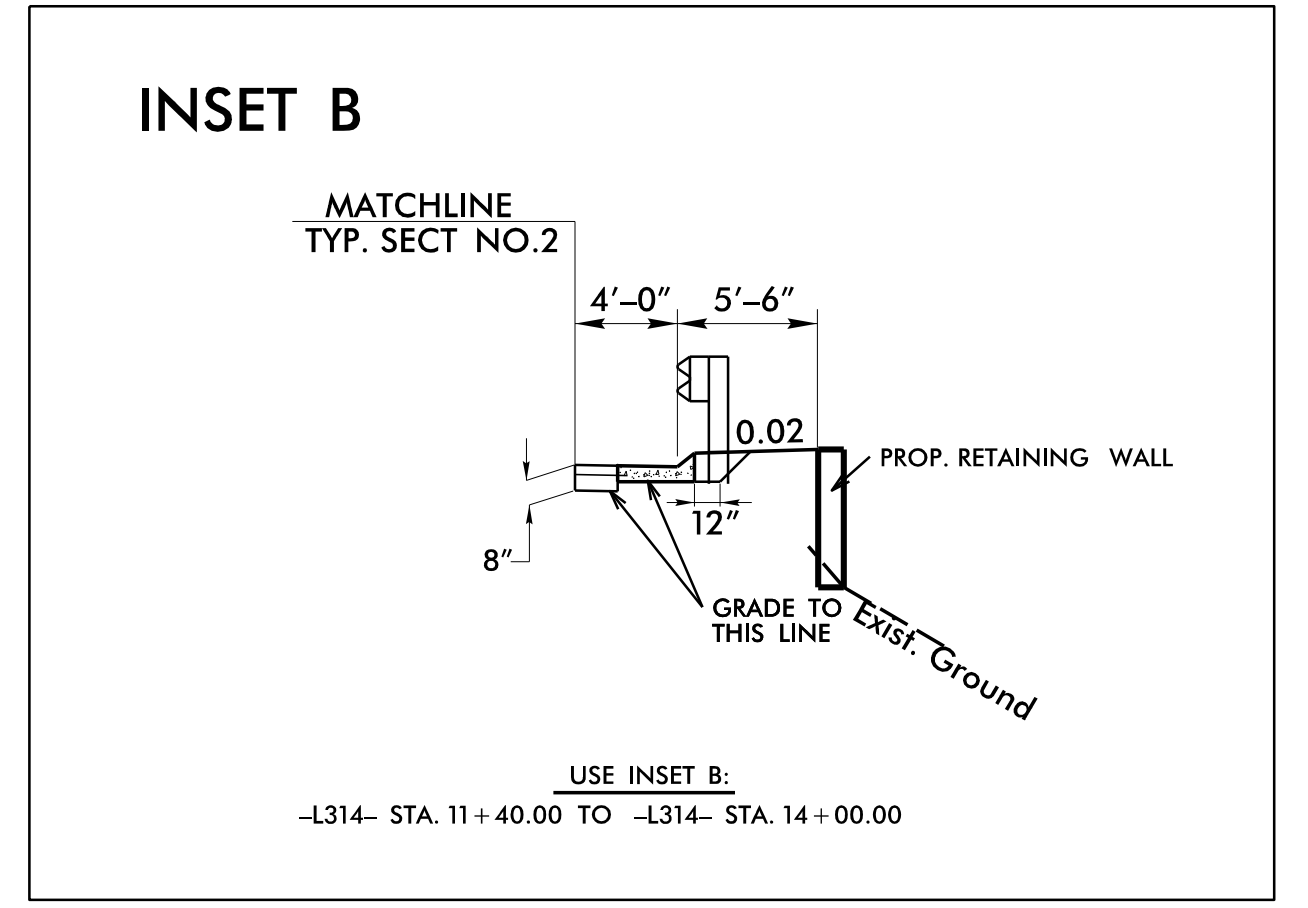
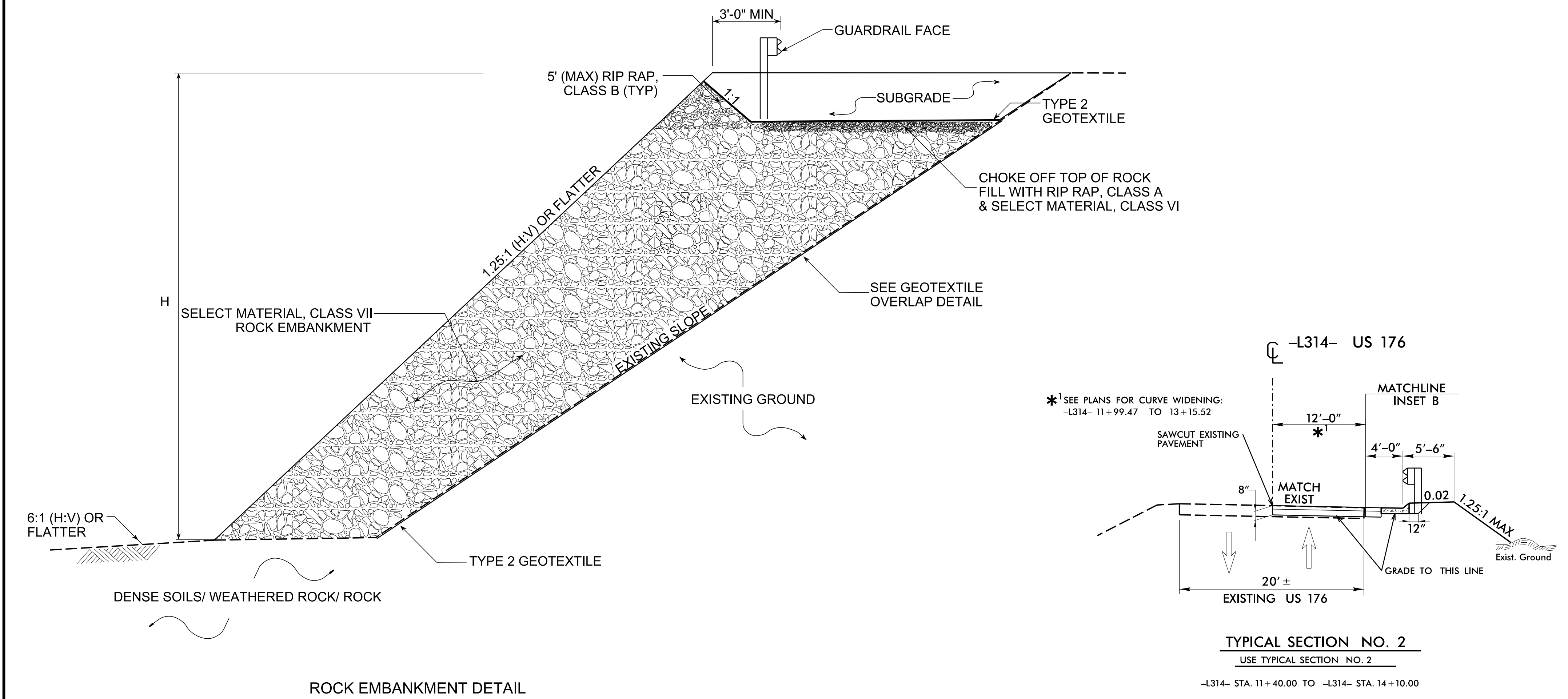

- NOTES:**
1. USE ROCK EMBANKMENTS WHERE SLOPES WITH AN INCLINATION OF UP TO 1.25:1 (H:V) ARE PLANNED: -L314- STA. 14+00.00 TO -L314- STA. 14+10.00
 2. THE MAXIMUM ALLOWABLE HEIGHT FOR THE ROCK EMBANKMENT DETAIL IS 80'.
 3. FOR ROCK EMBANKMENT, BENCH EXISTING SLOPE IN ACCORDANCE WITH SECTION 235 OF THE STANDARD SPECIFICATIONS, WHERE POSSIBLE.
 4. FOR ROCK EMBANKMENTS, SEE ROCK EMBANKMENTS SPECIAL PROVISION.

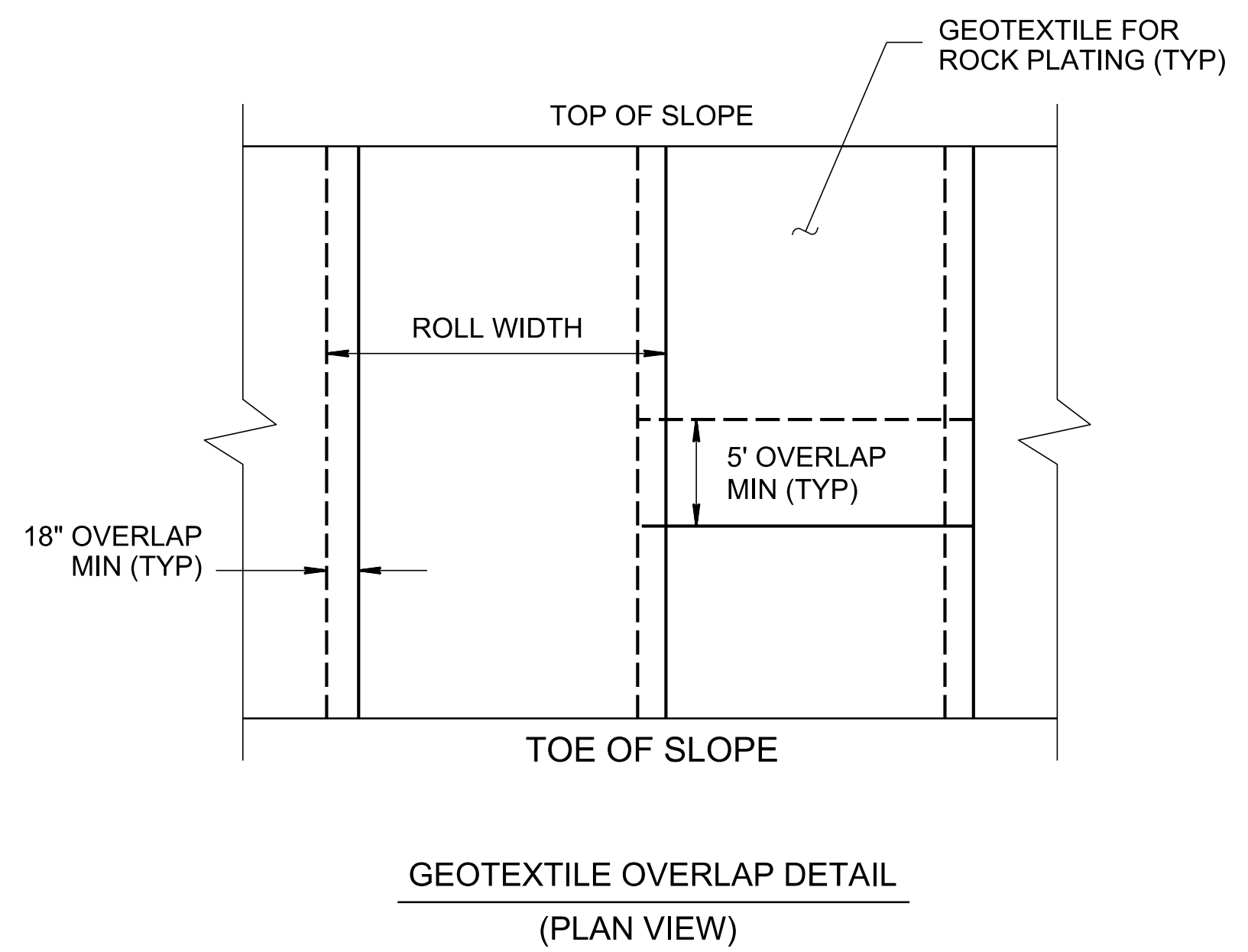

ESTIMATED SITE 314 QUANTITIES	
ROCK EMBANKMENTS	15 TONS
GEOTEXTILE FOR ROCK EMBANKMENTS	25 SY

PROJECT NO.: W03293
 POLK COUNTY
 STATION: -L314- STA. 11+40.00 TO 14+00.00, RT

PREPARED BY: KND	DATE: 07/25
REVIEWED BY: REK	DATE: 07/25

Prepared in the Office of:

CAROLINUS GEOTECHNICAL GROUP
 1805 SARDIS ROAD NORTH
 SUITE 100
 CHARLOTTE, NC 28270
 (980) 339-8684

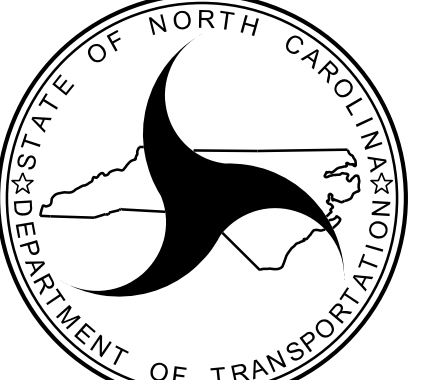
 NORTH CAROLINA
 DEPARTMENT OF TRANSPORTATION
 DIVISION OF HIGHWAYS
GEOTECHNICAL ENGINEERING UNIT

SITE 314 ROCK EMBANKMENTS					
REVISIONS					
NO.	BY	DATE	NO.	BY	DATE
1	-	-	3	-	-
2	-	-	4	-	-

SHEET NO. 2G-1

COMPUTED BY: SGM DATE: 10/8/2025
 CHECKED BY: JLT DATE: 11/10/2025

PROJECT NO.	SHEET NO.
W03293	3B-1

**STATE OF NORTH CAROLINA
 DIVISION OF HIGHWAYS**

SUMMARY OF EARTHWORK
 IN CUBIC YARDS

NOTE: EARTHWORK QUANTITIES ARE CALCULATED BY TGS ENGINEERS. THESE EARTHWORK QUANTITIES ARE BASED IN PART ON SUBSURFACE DATA PROVIDED BY THE GEOTECHNICAL ENGINEERING UNIT.

APPROXIMATE QUANTITIES ONLY. UNCLASSIFIED EXCAVATION, BORROW EXCAVATION, FINE GRADING, CLEARING AND GRUBBING, AND REMOVAL OF EXISTING PAVEMENT WILL BE PAID FOR AT THE LUMP SUM PRICE FOR "GRADING".

PROJECT TOTALS	EXCAVATION TOTAL UNCLASS.	BORROW	WASTE
SITE			
SITE 316		320	
SITE 314	51	274	
SITE 318	22	1,300	
SITE 319	13	265	
SITE 320	80		78
SITE 321	956		774
GRAND TOTALS	1,122	2,159	852
SAY W03293 (Part I)	1,130	2,160	

SEE SHEET 3B-2 FOR EARTHWORK SUMMARY
 SEE SHEET 3B-2 FOR EARTHWORK SUMMARY
 SEE SHEET 3B-2 FOR EARTHWORK SUMMARY
 SEE SHEET 3B-2 FOR EARTHWORK SUMMARY
 SEE SHEET 3B-2 FOR EARTHWORK SUMMARY
 SEE SHEET 3B-3 FOR EARTHWORK SUMMARY

SAY W03293 (Part II)	1,260	2,050
SAY W03293 (Combined Project)	2,390	4,210

	Part I	Part II	Combined Project
BORROW FOR WIRE FORM EMBANKMENT (CY)	N/A	4,900	4,900
SELECT GRANULAR MATERIAL (CY)	1,200	1,800	3,000
EST. SHALLOW UNDERCUT (CY)	300	450	750
ESTIMATED UNDERCUT TO BE USED AT THE DISCRETION OF THE RESIDENT ENGINEER PER GEOTECH RECOMMENDATION. (CY)	1,200	1,800	3,000

COMPUTED BY: SGM DATE: 10/8/25
 CHECKED BY: JLT DATE: 11/10/2025

PROJECT NO. W03293 SHEET NO. 3B-2

STATE OF NORTH CAROLINA DIVISION OF HIGHWAYS

NOTE: EARTHWORK QUANTITIES ARE CALCULATED BY TGS ENGINEERS. THESE EARTHWORK QUANTITIES ARE BASED IN PART ON SUBSURFACE DATA PROVIDED BY THE GEOTECHNICAL ENGINEERING UNIT.

SUMMARY OF EARTHWORK

IN CUBIC YARDS

Site 316

Station	Station	Uncl. Excav.	Embank. +%	Borrow	Waste
-L316- 10+85.00	-L316-13+50.00	27	305	278	
SUBTOTALS:		27	305	278	
TOTALS:		27	305	278	
LOSS DUE TO CLEARING & GRUBBING		-27		27	
PROJECT TOTALS:		0	305	305	
EST. 5% TO REPLACE TOP SOIL ON BORROW PIT				15	
GRAND TOTALS:			305	320	

SELECT GRANULAR MATERIAL = 200 CUBIC YARDS
 EST. SHALLOW UNDERCUT = 50 CUBIC YARDS

PER GEOTECH RECOMMENDATION, ESTIMATED 200 CUBIC YARDS OF UNDERCUT TO BE USED IN THE DISCRETION OF THE RESIDENT ENGINEER.

APPROXIMATE QUANTITIES ONLY. BORROW EXCAVATION, FINE GRADING, CLEARING AND GRUBBING, AND REMOVAL OF EXISTING PAVEMENT WILL BE PAID FOR AT THE LUMP SUM PRICE FOR "GRADING".

SUMMARY OF EARTHWORK

IN CUBIC YARDS

Site 318

Station	Station	Uncl. Excav.	Embank. +%	Borrow	Waste
-L317- 14+40.00	-L317- 16+50.00	72	1260	1188	
SUBTOTALS:		72	1260	1188	
TOTALS:		72	1260	1188	
LOSS DUE TO CLEARING & GRUBBING		-50		50	
PROJECT TOTALS:		22	1260	1238	
EST. 5% TO REPLACE TOP SOIL ON BORROW PIT				62	
GRAND TOTALS:		22	1,260	1,300	

SELECT GRANULAR MATERIAL = 200 CUBIC YARDS
 EST. SHALLOW UNDERCUT = 50 CUBIC YARDS

PER GEOTECH RECOMMENDATION, ESTIMATED 200 CUBIC YARDS OF UNDERCUT TO BE USED IN THE DISCRETION OF THE RESIDENT ENGINEER.

APPROXIMATE QUANTITIES ONLY. UNCLASSIFIED EXCAVATION, BORROW EXCAVATION, FINE GRADING, CLEARING AND GRUBBING, AND REMOVAL OF EXISTING PAVEMENT WILL BE PAID FOR AT THE LUMP SUM PRICE FOR "GRADING".

SUMMARY OF EARTHWORK

IN CUBIC YARDS

Site 314

Station	Station	Uncl. Excav.	Embank. +%	Borrow	Waste
-L314- 11+10.00	-L314- 14+50.00	101	312	211	
SUBTOTALS:		101	312	211	
TOTALS:		101	312	211	
LOSS DUE TO CLEARING & GRUBBING		-50		50	
PROJECT TOTALS:		51	312	261	
EST. 5% TO REPLACE TOP SOIL ON BORROW PIT				13	
GRAND TOTALS:		51	312	274	

SELECT GRANULAR MATERIAL = 200 CUBIC YARDS
 EST. SHALLOW UNDERCUT = 50 CUBIC YARDS

PER GEOTECH RECOMMENDATION, ESTIMATED 200 CUBIC YARDS OF UNDERCUT TO BE USED IN THE DISCRETION OF THE RESIDENT ENGINEER.

APPROXIMATE QUANTITIES ONLY. UNCLASSIFIED EXCAVATION, BORROW EXCAVATION, FINE GRADING, CLEARING AND GRUBBING, AND REMOVAL OF EXISTING PAVEMENT WILL BE PAID FOR AT THE LUMP SUM PRICE FOR "GRADING".

SUMMARY OF EARTHWORK

IN CUBIC YARDS

Site 319

Station	Station	Uncl. Excav.	Embank. +%	Borrow	Waste
-L319- 12+50.00	-L319- 15+00.00	63	265	202	
SUBTOTALS:		63	265	202	
TOTALS:		63	265	202	
LOSS DUE TO CLEARING & GRUBBING		-50		50	
PROJECT TOTALS:		13	265	252	
EST. 5% TO REPLACE TOP SOIL ON BORROW PIT				13	
GRAND TOTALS:		13	265	265	

SELECT GRANULAR MATERIAL = 200 CUBIC YARDS
 EST. SHALLOW UNDERCUT = 50 CUBIC YARDS

PER GEOTECH RECOMMENDATION, ESTIMATED 200 CUBIC YARDS OF UNDERCUT TO BE USED IN THE DISCRETION OF THE RESIDENT ENGINEER.

APPROXIMATE QUANTITIES ONLY. UNCLASSIFIED EXCAVATION, BORROW EXCAVATION, FINE GRADING, CLEARING AND GRUBBING, AND REMOVAL OF EXISTING PAVEMENT WILL BE PAID FOR AT THE LUMP SUM PRICE FOR "GRADING".

SUMMARY OF EARTHWORK

IN CUBIC YARDS

Site 320

Station	Station	Uncl. Excav.	Embank. +%	Borrow	Waste
-L320- 12+00.00	-L320- 16+50.00	130	2		128
SUBTOTALS:		130	2		128
TOTALS:		130	2		128
LOSS DUE TO CLEARING & GRUBBING		-50			-50
PROJECT TOTALS:		80	2		78
EST. 5% TO REPLACE TOP SOIL ON BORROW PIT					
GRAND TOTALS:		80	2		78

SELECT GRANULAR MATERIAL = 200 CUBIC YARDS
 EST. SHALLOW UNDERCUT = 50 CUBIC YARDS

PER GEOTECH RECOMMENDATION, ESTIMATED 200 CUBIC YARDS OF UNDERCUT TO BE USED IN THE DISCRETION OF THE RESIDENT ENGINEER.

APPROXIMATE QUANTITIES ONLY. UNCLASSIFIED EXCAVATION, FINE GRADING, CLEARING AND GRUBBING, AND REMOVAL OF EXISTING PAVEMENT WILL BE PAID FOR AT THE LUMP SUM PRICE FOR "GRADING".

COMPUTED BY: SGM DATE: 10/8/2025
 CHECKED BY: JLT DATE: 11/10/2025

PROJECT NO. SHEET NO.
 W03293 3B-3

STATE OF NORTH CAROLINA DIVISION OF HIGHWAYS

NOTE: EARTHWORK QUANTITIES ARE CALCULATED BY TGS ENGINEERS. THESE EARTHWORK QUANTITIES ARE BASED IN PART ON SUBSURFACE DATA PROVIDED BY THE GEOTECHNICAL ENGINEERING UNIT.

SUMMARY OF EARTHWORK

IN CUBIC YARDS

Site 321

Station	Station	Uncl. Excav.	Embank. +%	Borrow	Waste
-L320- 16+50.00	-L320- 20+50.00	1006	182		824
SUBTOTALS:		1006	182		824
TOTALS:		1006	182		824
LOSS DUE TO CLEARING & GRUBBING		-50			-50
PROJECT TOTALS:		956	182		774
EST. 5% TO REPLACE TOP SOIL ON BORROW PIT					
GRAND TOTALS:		956	182		774

SELECT GRANULAR MATERIAL = 200 CUBIC YARDS
 EST. SHALLOW UNDERCUT = 50 CUBIC YARDS

PER GEOTECH RECOMMENDATION, ESTIMATED 200 CUBIC YARDS OF UNDERCUT TO BE USED IN THE DISCRETION OF THE RESIDENT ENGINEER.

APPROXIMATE QUANTITIES ONLY. UNCLASSIFIED EXCAVATION, FINE GRADING, CLEARING AND GRUBBING, AND REMOVAL OF EXISTING PAVEMENT WILL BE PAID FOR AT THE LUMP SUM PRICE FOR "GRADING".

PAVEMENT REMOVAL SUMMARY

IN SQUARE YARDS

Site	SURVEY LINE	Station	Station	LOCATION LT/RT/CL	ASPHALT REMOVAL	SITE TOTAL
316	-L316-	10+85	13+50	LT	16.76	16.76
314	-L314-	11+10	14+50	RT	530.54	530.54
318	-L317-	14+40	16+50	CL	794.04	794.04
319	-L319-	12+50	15+00	RT	347.84	347.84
320	-L320-	12+00	16+50	RT	634.97	634.97
321	-L320-	16+50	20+50	RT	557.86	557.86

TOTAL (PART I):	2,882.01
------------------------	-----------------

SAY (PART I):	2,900
----------------------	--------------

SAY (PART II):	4,350
-----------------------	--------------

SAY (COMBINED PROJECT):	7,250
--------------------------------	--------------

SHOULDER BERM GUTTER SUMMARY

IN FEET

Site	LINE	Station	Station	LENGTH	SAY
314	-L314-, RT	11+40	14+10	270.00	280
320	-L320-, RT	12+00	16+50	450.00	470
321	-L320-, RT	16+50	17+00	50.00	60

TOTAL (PART I):	770.00	810
------------------------	--------	------------

TOTAL (PART II):	2,262.00	2,370
-------------------------	----------	--------------

COMBINED PROJECT TOTAL	3,032.00	3,180
-------------------------------	----------	--------------

COMPUTED BY: SGM DATE: 10/8/25
 CHECKED BY: JLT DATE: 11/10/25

DIVISION OF HIGHWAYS
 STATE OF NORTH CAROLINA

PROJECT REFERENCE NO. W03293 SHEET NO. 3B-4

"N" = DISTANCE FROM EDGE OF LANE TO FACE OF GUARDRAIL
 TOTAL SHOULDER WIDTH = DISTANCE FROM EDGE OF TRAVEL LANE TO SHOULDER BREAK POINT.
 FLARE LENGTH = DISTANCE FROM LAST SECTION OF PARALLEL GUARDRAIL TO END OF GUARDRAIL
 W = TOTAL WIDTH OF FLARE FROM BEGINNING OF TAPER TO END OF GUARDRAIL

GUARDRAIL SUMMARY

G = GATING IMPACT ATTENUATOR TYPE 350
 NG = NON-GATING IMPACT ATTENUATOR TYPE 350

SURVEY LINE	BEG. STA.	END STA.	LOCATION	LENGTH			WARRANT POINT		"N" DIST. FROM E.O.L.	TOTAL SHOULDER WIDTH	FLARE LENGTH		W		ANCHORS				IMPACT ATTENUATOR		EXTRA DEPTH POSTS	REMOVE EXISTING GUARDRAIL	REMOVE AND RESET EXISTING GUARDRAIL	REMARKS				
				STRAIGHT	SHOP CURVED	DOUBLE FACED	APPROACH END	TRAILING END			APPROACH END	TRAILING END	APPROACH END	TRAILING END	CAT-1	GREU, TL-3	G	NG										
SITE 316																												
-L316-	10+85.00	13+22.50	LT	237.50			12+70	11+25	4'	8'	50		1'															
SUB-TOTALS				237.50																								
LESS ANCHOR DEDUCTIONS																												
			GREU, TL-3	2 @ 50.00 ft	100.00						12.5																	
ANCHOR TOTALS				100.00																								
SITE 316 TOTALS				137.50																								
SAY				150.00			Additional Guardrail Posts = 2 EA																					
SITE 314																												
-L314-	11+10.00	14+35.00	RT	325.00																		87.3		TIE TO EXIST. GUARDRAIL				
SITE 314 TOTALS				325.00																			87.3					
SAY				337.5			Additional Guardrail Posts = 2 EA																90					
SITE 317																												
-L317-	12+93+/-	13+61+/-	LT																					97.4				
SITE 317 TOTALS																								97.4				
SAY																								100				
SITE 318																												
-L317-	14+50.00	16+50.00	RT	200.00			15+00		4'	7'	50'		1'										126.1		TIE TO EXIST. GUARDRAIL			
SUB-TOTALS				200.00																								
LESS ANCHOR DEDUCTIONS																												
			GREU, TL-3	1 @ 50.00 ft	50.00																							
ANCHOR TOTALS				50.00																								
SITE 318 TOTALS				150.00																				126.1				
SAY				162.5			Additional Guardrail Posts = 2 EA																	130				
SITE 319																												
-L319-	12+50.00	15+00.00	RT	250.00																			250		TIE TO EXIST. GUARDRAIL			
SITE 319 TOTALS				250.00																				250.0				
SAY				262.5			Additional Guardrail Posts = 2 EA																	255				
SITE 320																												
-L320-	12+00.00	16+50.00	RT	450.00																			457.6		TIE TO EXIST. GUARDRAIL			
SITE 320 TOTALS				450.00																				457.6				
SAY				456.25			Additional Guardrail Posts = 2 EA																	460				
SITE 321																												
-L320-	16+50.00	17+43.75	RT	93.75																			90.2		TIE TO EXIST. GUARDRAIL			
SITE 321 TOTALS				93.75																				90.2				
SAY				100.0			Additional Guardrail Posts = 2 EA																	95				
W03293 (PART I) TOTALS				1468.75			Additional Guardrail Posts = 12 EA																	3		1,030	100	
W03293 (PART II) TOTALS				3206.25			Additional Guardrail Posts = 18 EA																		4		2,031	0
W03293 COMBINED PLANS TOTALS				4675.00			Additional Guardrail Posts = 30 EA																		7		3,061	100

COMPUTED BY: PMP DATE: 07/31/2025
 CHECKED BY: KND DATE: 07/31/2025

(9-17-24)

PROJECT NO. W03293	SHEET NO. 3G-1
-----------------------	-------------------

**STATE OF NORTH CAROLINA
 DIVISION OF HIGHWAYS**

PART I

SUMMARY OF SUBSURFACE DRAINAGE

LINE	Station	Station	Location LT/RT/CL	Drain Type* UD/BD/SD	LF
CONTINGENCY (SITE 314 / 18314.1075023)					
				SD	100
CONTINGENCY (SITE 316 / 18314.1075025)					
				SD	100
CONTINGENCY (SITE 318 / 18314.1075027)					
				SD	100
CONTINGENCY (SITE 319 / 18314.1075028)					
				SD	100
CONTINGENCY (SITE 320 / 18314.1075029)					
				SD	100
CONTINGENCY (SITE 321 / 18314.1075030)					
				SD	100
TOTAL LF:					600

*UD = Underdrain
 *BD = Blind Drain
 *SD = Subsurface Drain

SUMMARY OF ROCK PLATING

LINE	Beginning Slope (H:V)	Approx. Station	Ending Slope (H:V)	Approx. Station	Location LT/RT	Rock Plating Detail No. 1/2/3/4	Riprap Class* 1/2/B	Rock Plating SY
SITE 318 / 18314.1075027								
-L317-	1.5:1	14+50	1.5:1	16+50	RT	2		2150
SITE 321 / 18314.1075030								
-L320-	1.5:1	17+50	1.5:1	19+50	LT	4		1525
TOTAL SY:								3675

*Use Class 1, 2 or B riprap if riprap class is not shown for rock plating location.

SUMMARY OF AGGREGATE SUBGRADE/STABILIZATION

LINE	Station	Station	Aggregate Type* ASU(1/2)/ AST	Aggregate Thickness INCHES [8" for ASU(2)]	Shallow Undercut CY	Class IV Subgrade Stabilization TONS	Geotextile for Subgrade Stabilization SY	Stabilizer Aggregate TONS	Class IV Aggregate Stabilization TONS
CONTINGENCY (SITE 314 / 18314.1075023)									
			ASU1	12	50	100	150		
CONTINGENCY (SITE 316 / 18314.1075025)									
			ASU1	12	50	100	150		
CONTINGENCY (SITE 318 / 18314.1075027)									
			ASU1	12	50	100	150		
CONTINGENCY (SITE 319 / 18314.1075028)									
			ASU1	12	50	100	150		
CONTINGENCY (SITE 320 / 18314.1075029)									
			ASU1	12	50	100	150		
CONTINGENCY (SITE 321 / 18314.1075030)									
			ASU1	12	50	100	150		
TOTAL CY/TONS/SY:					300	600**	900**	0	0

*ASU(1/2) = Aggregate Subgrade (Type 1 or 2)

*AST = Aggregate Stabilization

**Total tons of "Class IV Subgrade Stabilization" and total square yards of "Geotextile for Subgrade Stabilization" are only the estimated quantities for ASU(1/2)/AST and may only represent a portion of the subgrade stabilization and geotextile quantities shown in the Item Sheets of the Proposal.

8/17/99

REVISIONS

X:\Road\2025\Div 14 US 176 Repair\Roadway\Design\PlanSheets\US176_Rdy_psh_04.dgn
 12/28/2025 10:00 AM
 User: jsm

PROJECT REFERENCE NO. W03293	SHEET NO. 4
RW SHEET NO.	
ROADWAY DESIGN ENGINEER JIMMY L. TERRY NORTH CAROLINA PROFESSIONAL SEAL 35018 1/5/2026	HYDRAULICS ENGINEER JOHN W. TWISDOLE, JR. NORTH CAROLINA PROFESSIONAL SEAL 024897 1/5/2026
DOCUMENT NOT CONSIDERED FINAL UNLESS ALL SIGNATURES COMPLETED	
TGS ENGINEERS 201 W. MARION ST., STE 200 SHELBY, NC 28150 PH: (704) 476-0003 CORP. LICENSE NO.: C-0275	

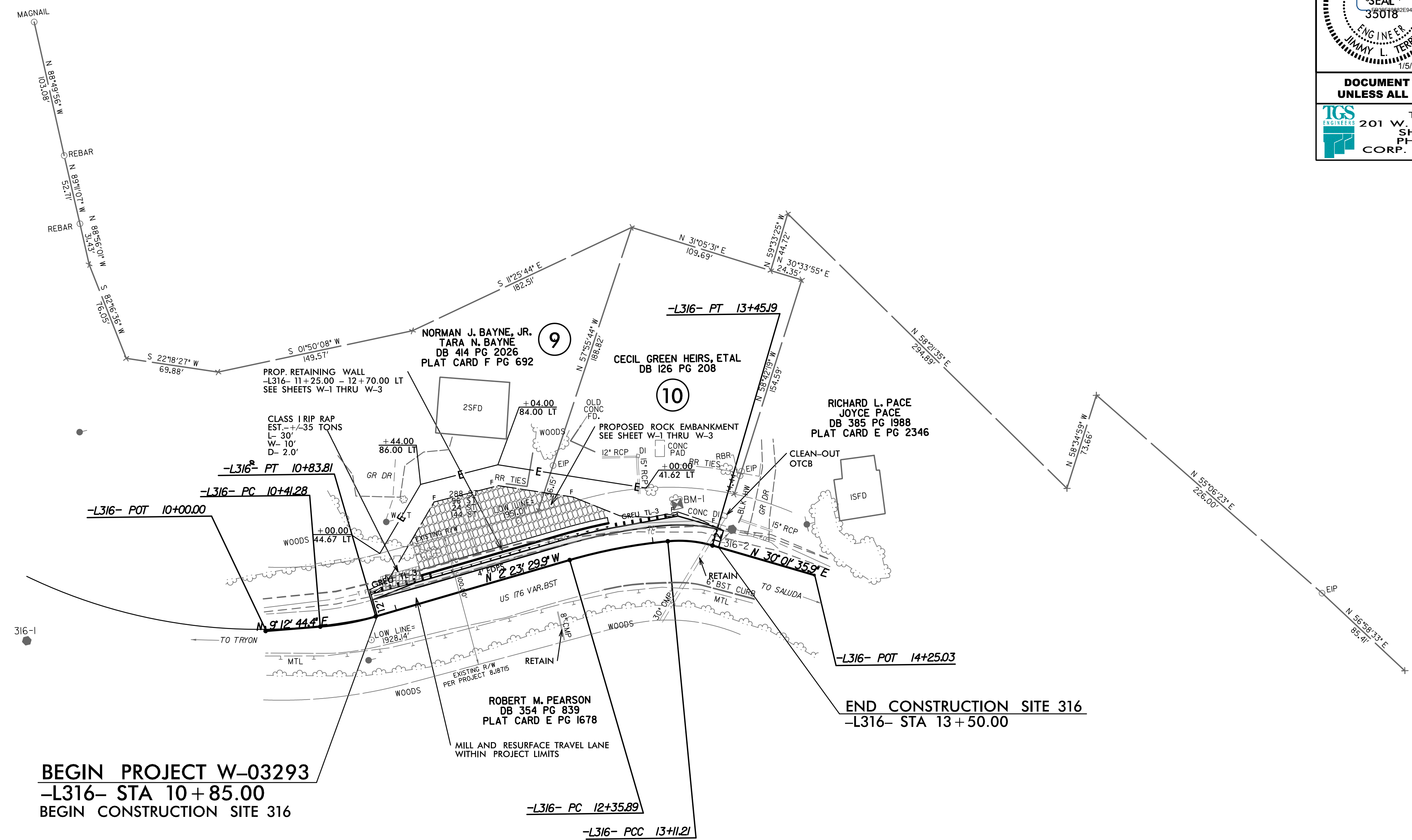
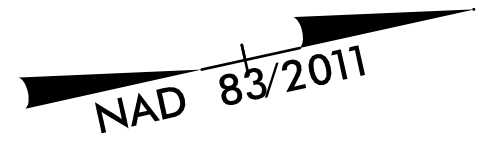

-L316- CURVE DATA

PI Sta	PI Sta	PI Sta
10+62.62	12+73.66	13+28.41
$\Delta = 11^{\circ}36'14.4\"$ (LT)	$\Delta = 10^{\circ}47'22.5\"$ (RT)	$\Delta = 21^{\circ}37'43.3\"$ (RT)
$D = 27^{\circ}17'01.3\"$	$D = 14^{\circ}19'26.2\"$	$D = 63^{\circ}39'43.1\"$
$L = 42.53'$	$L = 75.33'$	$L = 33.97'$
$T = 21.34'$	$T = 37.77'$	$T = 17.19'$
$R = 210.00'$	$R = 400.00'$	$R = 90.00'$
SE = EXIST.	SE = EXIST.	SE = EXIST.

PROJECT REFERENCE NO. W03293		SHEET NO. 5	
RW SHEET NO.		HYDRAULICS ENGINEER	
ROADWAY DESIGN ENGINEER		ENGINEER	
DOCUMENT NOT CONSIDERED FINAL UNLESS ALL SIGNATURES COMPLETED			
 TGS ENGINEERS 201 W. MARION ST., STE 200 SHELBY, NC 28150 PH (704) 476-0003 CORP. LICENSE NO.: C-0275			

NAD 83/2011

REVISIONS
 5/21/2026
 14 US 176 Repair Roadway Design Plan Sheets\US176_Rdy_psh_05.dgn
 User: jturner

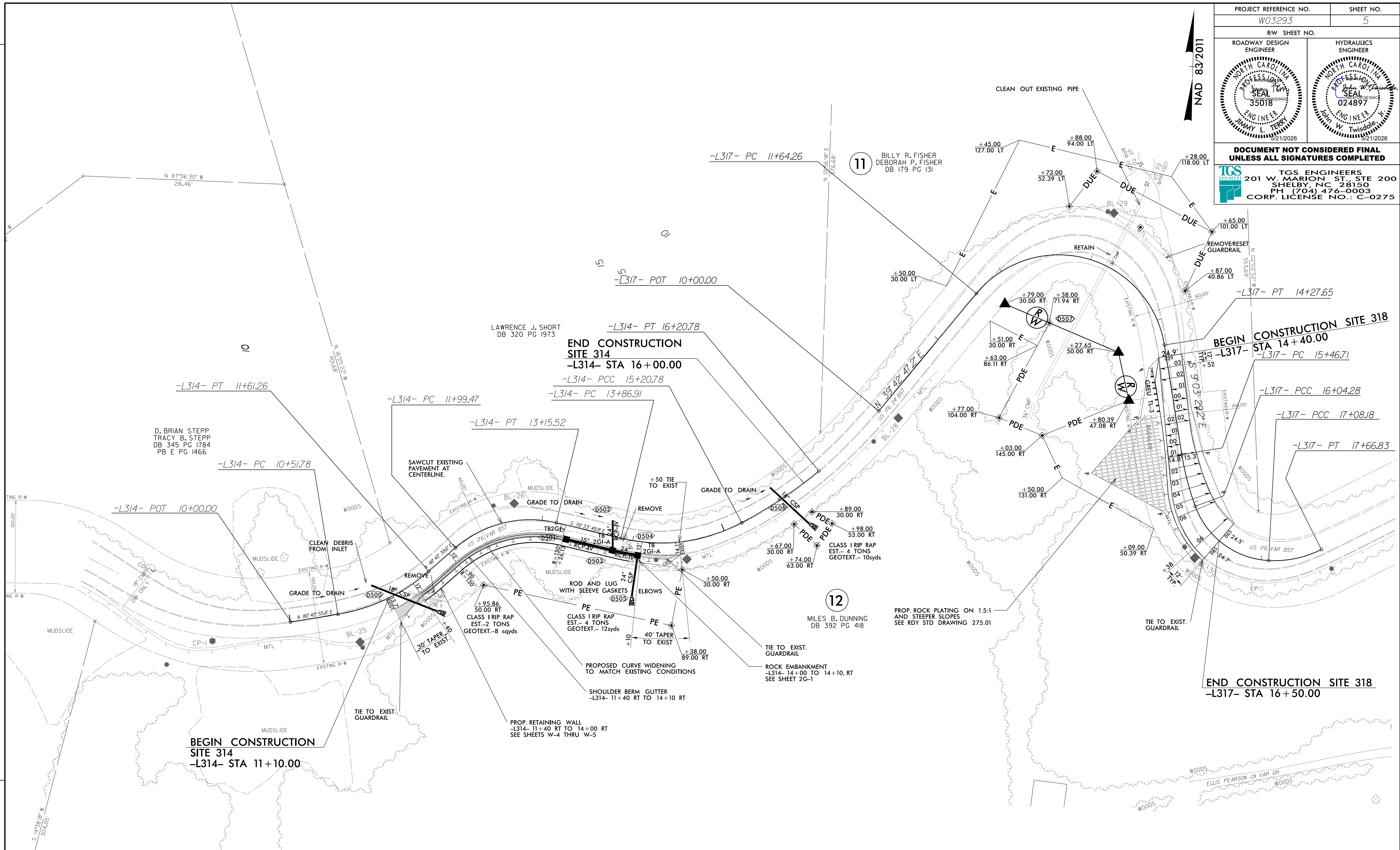

-L314- Curve Data

PI Sta	PI Sta	PI Sta	PI Sta
11+07.99	12+62.35	14+56.93	15+70.96
$\Delta = 32^{\circ} 00' 17.0''$ (LT)	$\Delta = 54^{\circ} 43' 31.5''$ (RT)	$\Delta = 41^{\circ} 27' 40.2''$ (LT)	$\Delta = 11^{\circ} 38' 43.7''$ (LT)
D = 29' 13' 57.1"	D = 47' 09' 25.3"	D = 30' 58' 14.5"	D = 11' 38' 43.7"
L = 109.48'	L = 116.05'	L = 133.87'	L = 100.00'
T = 56.21'	T = 62.88'	T = 70.02'	T = 50.17'
R = 196.00'	R = 121.50'	R = 185.00'	R = 492.00'
SE = EXIST.	SE = EXIST.	SE = EXIST.	SE = EXIST.

-L317- Curve Data

PI Sta	PI Sta	PI Sta	PI Sta
14+17.95	15+75.58	16+63.07	17+38.18
$\Delta = 131^{\circ} 13' 43.6''$ (RT)	$\Delta = 10^{\circ} 59' 48.1''$ (LT)	$\Delta = 66^{\circ} 53' 18.9''$ (LT)	$\Delta = 29^{\circ} 44' 01.6''$ (LT)
D = 49' 49' 20.7"	D = 19' 05' 54.9"	D = 64' 22' 38.2"	D = 50' 42' 14.9"
L = 263.39'	L = 57.58'	L = 103.90'	L = 58.64'
T = 253.69'	T = 28.88'	T = 58.78'	T = 30.00'
R = 115.00'	R = 300.00'	R = 89.00'	R = 113.00'
SE = 0.12	SE = 0.06	SE = EXIST.	SE = EXIST.
DS = 20 MPH	DS = 30 MPH		

FOR -L317 PROFILE, SEE SHEET NO. 8

-L320- CURVE DATA

PI Sta 10+99.39 Δ = 10° 01' 34.8" (LT) D = 8° 04' 11.4" L = 124.24' T = 62.28' R = 710.00' SE = EXIST.	PI Sta 12+38.45 Δ = 15° 52' 01.8" (LT) D = 20° 27' 46.0" L = 77.54' T = 39.02' R = 290.00' SE = EXIST.	PI Sta 13+73.53 Δ = 16° 21' 11.1" (RT) D = 19° 45' 25.8" L = 82.77' T = 41.67' R = 290.00' SE = EXIST.	PI Sta 15+36.23 Δ = 24° 24' 38.2" (LT) D = 22° 02' 12.6" L = 110.77' T = 56.24' R = 260.00' SE = EXIST.	PI Sta 16+65.69 Δ = 3° 44' 05.8" (RT) D = 6° 13' 40.1" L = 59.97' T = 30.00' R = 920.00' SE = EXIST.	PI Sta 18+54.39 Δ = 46° 21' 07.6" (LT) D = 27° 17' 01.3" L = 169.89' T = 89.90' R = 210.00' SE = EXIST.	PI Sta 21+27.70 Δ = 4° 06' 20.2" (RT) D = 1° 20' 49.9" L = 304.75' T = 152.44' R = 4253.00' SE = EXIST.
--	--	--	---	--	---	---

PROJECT REFERENCE NO. W03293	SHEET NO. 7
RW SHEET NO.	
ROADWAY DESIGN ENGINEER JIMMY L. TERRY 1/5/2026	HYDRAULICS ENGINEER JOHN W. TWISDALE, JR. 1/5/2026
DOCUMENT NOT CONSIDERED FINAL UNLESS ALL SIGNATURES COMPLETED	
TGS ENGINEERS 201 W. MARION ST., STE 200 SHELBY, NC 28150 PH: (704) 476-0003 CORP. LICENSE NO.: C-0275	

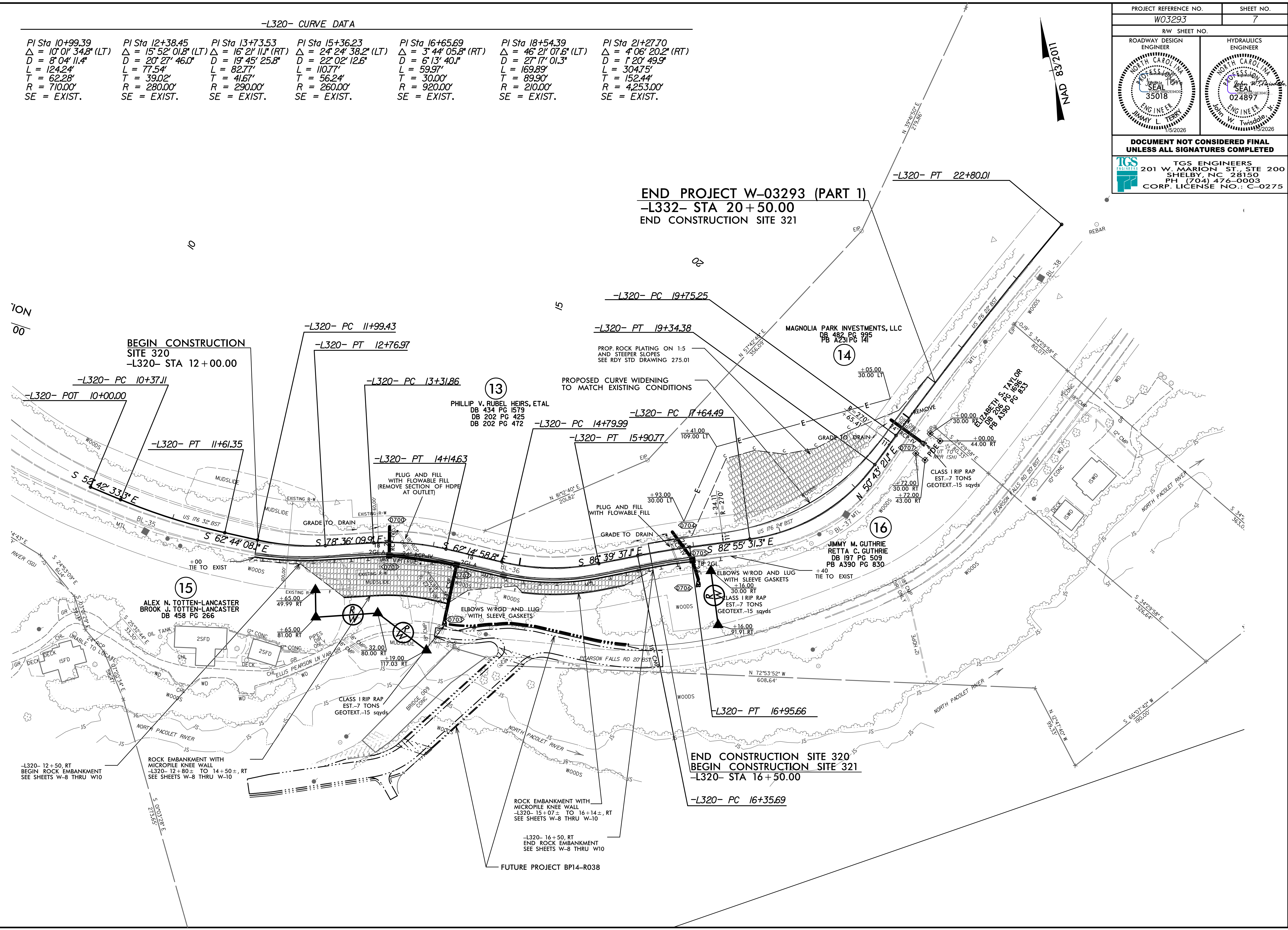

REVISIONS

12/30/2025
K:\Roadwork\Div 14 US 176 Repair\Roadway\Design\PlanSheets\US176_Rdy_psh_07.dgn
User: jstame

-L320- 12+50, RT
BEGIN ROCK EMBANKMENT
SEE SHEETS W-8 THRU W-10

ROCK EMBANKMENT WITH
MICROPILE KNEE WALL
-L320- 12+80 ± TO 14+50 ±, RT
SEE SHEETS W-8 THRU W-10

ROCK EMBANKMENT WITH
MICROPILE KNEE WALL
-L320- 15+07 ± TO 16+14 ±, RT
SEE SHEETS W-8 THRU W-10

-L320- 16+50, RT
END ROCK EMBANKMENT
SEE SHEETS W-8 THRU W-10

FUTURE PROJECT BP14-R038



END CONSTRUCTION SITE 320
BEGIN CONSTRUCTION SITE 321
-L320- STA 16+50.00

END PROJECT W-03293 (PART 1)
-L320- STA 20+50.00
END CONSTRUCTION SITE 321

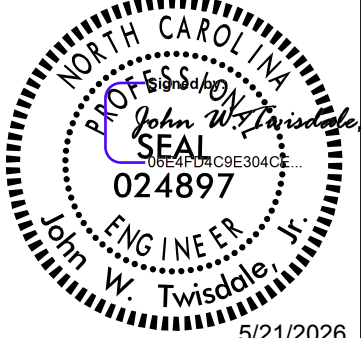

5/14/99

-L317-

PROJECT REFERENCE NO. W03293		SHEET NO. 8	
ROADWAY DESIGN ENGINEER		HYDRAULICS ENGINEER	
			
5/21/2026		5/21/2026	
DOCUMENT NOT CONSIDERED FINAL UNLESS ALL SIGNATURES COMPLETED			
 TGS ENGINEERS 201 W. MARION ST. STE 200 SHELBY, NC 28150 PH (704) 476-0003 CORP. LICENSE NO.: C-0275			

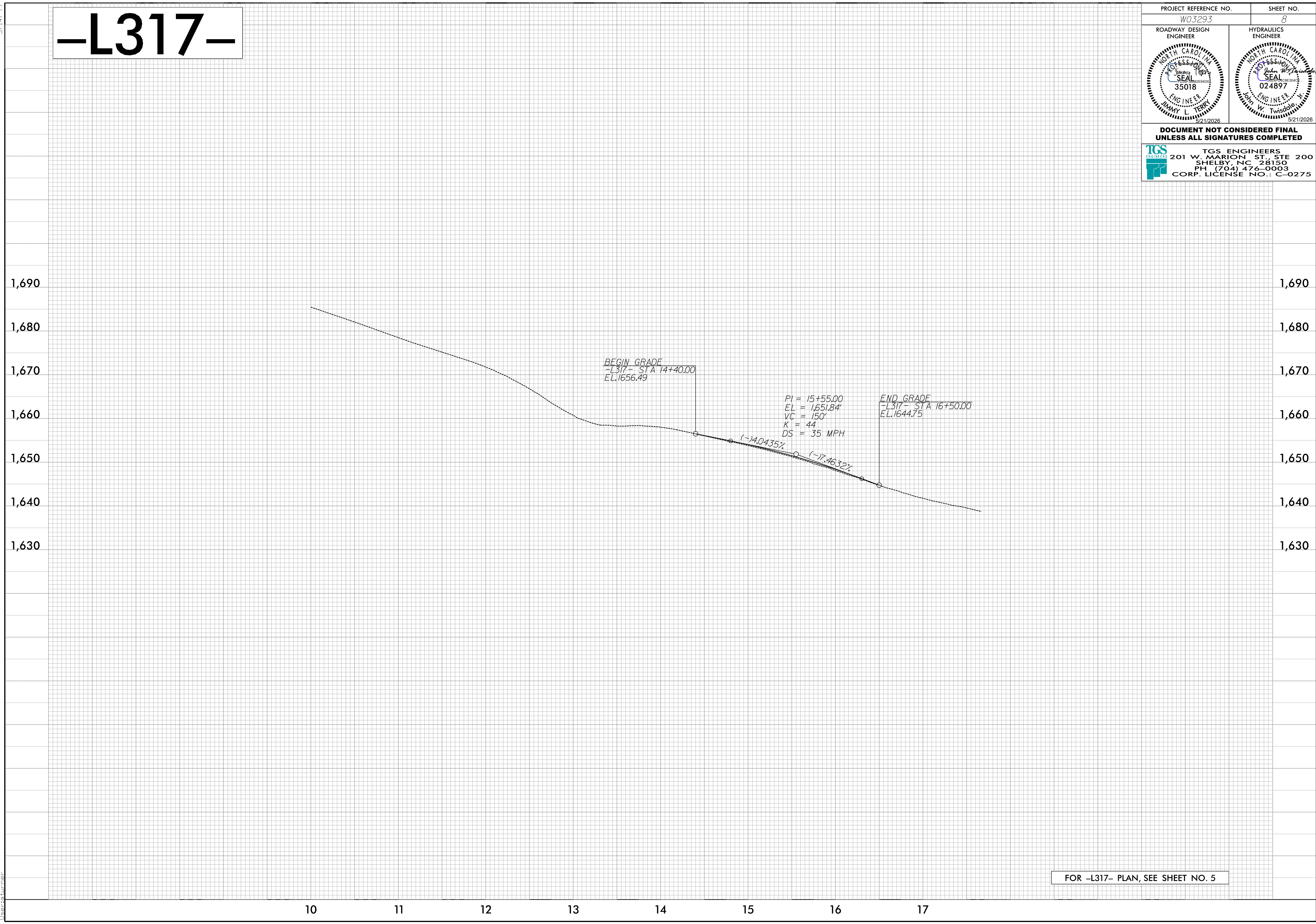

FOR -L317- PLAN, SEE SHEET NO. 5

5/21/2026
C:\Users\jturner\OneDrive\Documents\Roadway\Design\US176_Rdy.pfl.dgn
jturner