

18 CHANNEL IP CONFLICT MONITOR PROGRAMMING DETAIL

(remove jumpers and set switches as shown)

REMOVE DIODE JUMPERS 1-4, 1-9, 1-12, 1-14, 2-6, 2-9, 2-15, 4-9, 4-12, 4-14, 6-9, 6-15, 9-12, 9-14, 9-15 and 12-14.

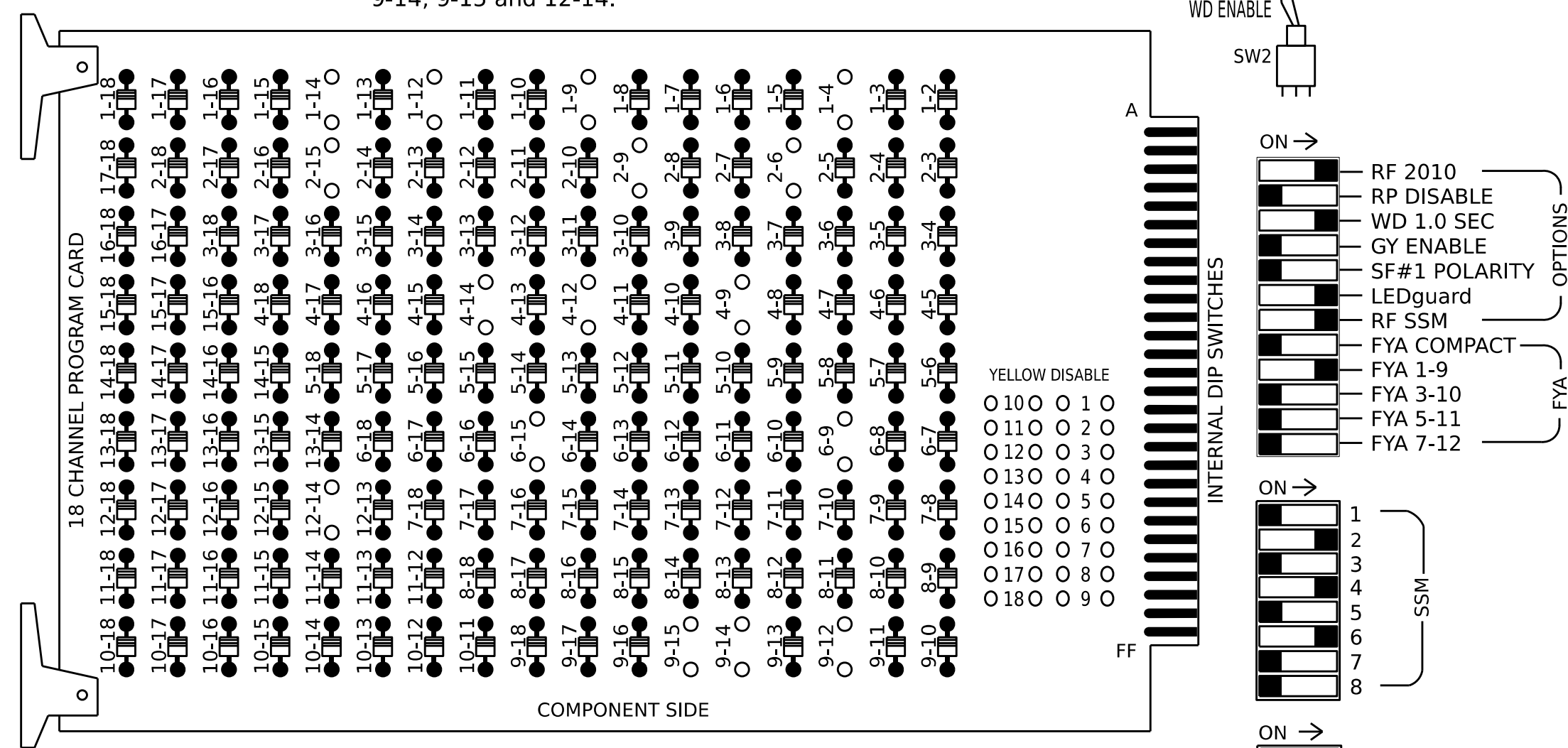

REMOVE JUMPERS AS SHOWN

NOTES:

1. Card is provided with all diode jumpers in place. Removal of any jumper allows its channels to run concurrently.
2. Ensure jumpers SEL2-SEL5 and SEL9 are present on the monitor board.
3. Ensure that the Red Enable is active at all times during normal operation.
4. Integrate monitor with Ethernet network in cabinet.

INPUT FILE POSITION LAYOUT (front view)

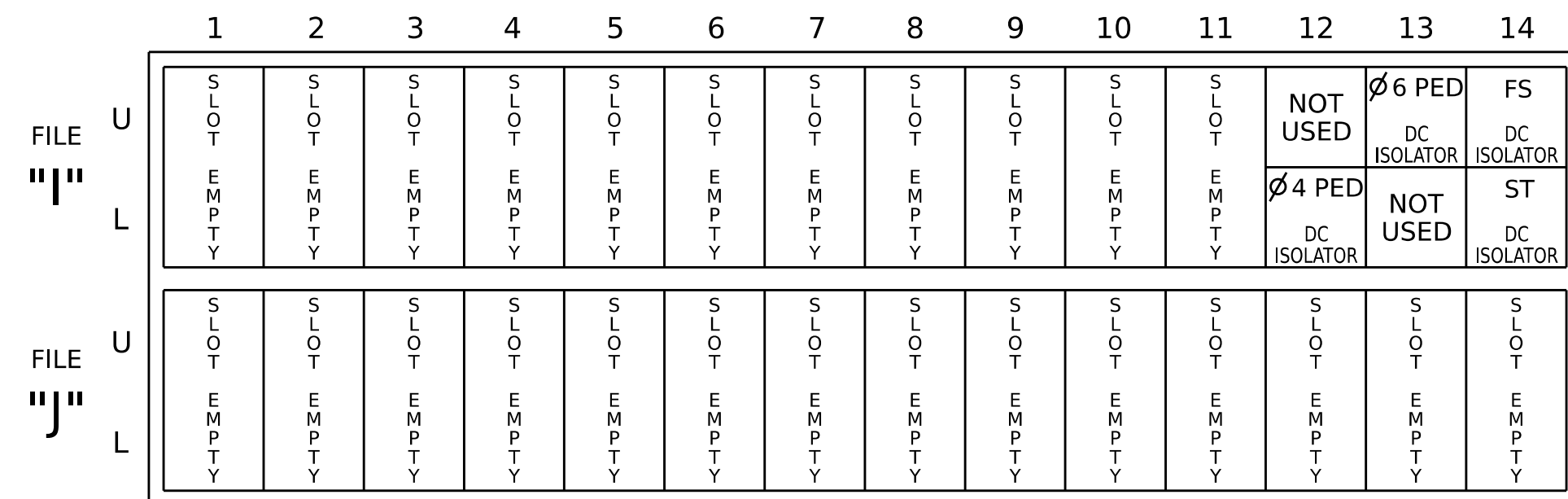

EX.: 1A, 2A, ETC. = LOOP NO.'S

FS = FLASH SENSE
ST = STOP TIME

INPUT FILE CONNECTION & PROGRAMMING CHART

LOOP NO.	LOOP TERMINAL	INPUT FILE POS.	PIN NO.	DETECTOR NO.	NEMA PHASE	DELAY TIME	EXTEND (STRETCH) TIME
PED PUSH BUTTONS							
P41,P42	TB8-5,6	I12L	69	PED 4	4 PED		
P61,P62	TB8-7,9	I13U	68	PED 6	6 PED		

NOTE:
INSTALL DC ISOLATORS IN INPUT FILE SLOTS I12 AND I13.

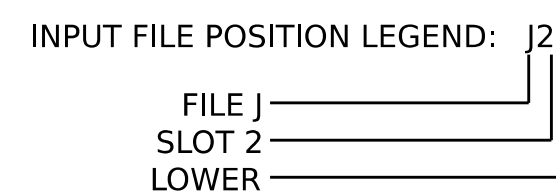

SPECIAL DETECTOR NOTE

Install a multi-zone microwave detection system for vehicle detection. Perform installation according to manufacturer's directions and NCDOT engineer-approved mounting locations to accomplish the detection schemes shown on the Signal Design Plans.

NOTES

1. To prevent "flash-conflict" problems, insert red flash program blocks for all vehicle load switches in the output file. The installer shall verify that signal heads flash in accordance with the Signal Plans.
 2. Program controller to start up in phases 2 Green and 6 Green/Don't Walk.
 3. Enable simultaneous gap-out feature for all phases.
 4. The cabinet and controller are part of the Hickory City System.
5. Default the controller before programming this detail.

EQUIPMENT INFORMATION

Controller..... 2070
 Cabinet..... 332 w/ Aux
 Software..... SE-PAC2070
 Cabinet Mount..... Base
 Output File Positions..... 18 With Aux. Output File
 Load Switches Used..... S1, S2, S5, S6, S8, S9, AUX S1, AUX S5
 Phases Used..... 2, 4, 4PED, 6, 6PED,
 Overlap "A"..... *
 Overlap "B"..... Not Used
 Overlap "C"..... Not Used
 Overlap "D"..... *
 Overlap "G"..... *

*See overlap programming detail on sheet 2

COUNTDOWN PEDESTRIAN SIGNAL OPERATION

Countdown Ped Signals are required to display timing only during Ped Clearance Interval. Consult Ped Signal Module user's manual for instructions on selecting this feature.

ADVANCE WALK PED PROGRAMMING DETAIL

(program controller as shown below)

1. From Main Menu select **3-PHASE DATA**
2. From PHASE DATA Submenu select **3-PEDESTRIAN DATA**
3. From PEDESTRIAN DATA Submenu select **3-PED OFFSET+**

PHASE	1	2	3	4	5	6	7	8
WOFF/10	0	0	0	40	0	70	0	0
MODE	0	0	0	0	0	0	0	0

CODES: * 0=ADVANCE 1=DELAY

ADVANCE WALK PED PROGRAMMING COMPLETE

FLASHER CIRCUIT MODIFICATION DETAIL

IN ORDER TO INSURE THAT SIGNALS FLASH CONCURRENTLY ON THE SAME APPROACH, MAKE THE FOLLOWING FLASHER CIRCUIT CHANGES:

1. ON REAR OF PDA - REMOVE WIRE FROM TERM. T2-4 AND TERMINATE ON T2-2.
2. ON REAR OF PDA - REMOVE WIRE FROM TERM. T2-5 AND TERMINATE ON T2-3.
3. REMOVE FLASHER UNIT 2.

THE CHANGES LISTED ABOVE TIES ALL PHASES AND OVERLAPS TO FLASHER UNIT 1.

SIGNAL HEAD HOOK-UP CHART

LOAD SWITCH NO.	S1	S2	S3	S4	S5	S6	S7	S8	S9	S10	S11	S12	AUX S1	AUX S2	AUX S3	AUX S4	AUX S5	AUX S6	
CMU CHANNEL NO.	1	2	13	3	4	14	5	6	15	7	8	16	9	10	17	11	12	18	
PHASE	OLG	2	2 PED	3	4	4 PED	5	6	6 PED	7	8	8 PED	OLA	OLB	SPARE	OLC	OLD	SPARE	
SIGNAL HEAD NO.	63	21	22	NU	NU	41	P41, P42	NU	61	62	P61, P62, P63, P64	NU	NU	NU	63	NU	NU	42,43	NU
RED	128	128						134	134				A121						
YELLOW	*	129	129						135	135									
GREEN			130							136									
RED ARROW						101													A101
YELLOW ARROW						102							A122						A102
FLASHING YELLOW ARROW													A123						
GREEN ARROW	127	130				103		136											A103
Hand icon							104			119									
Person icon							106			121									

NU = Not Used

*Denotes install load resistor. See LOAD RESISTOR INSTALLATION DETAIL this sheet.

*See pictorial of head wiring in detail this sheet.

#Load switch reassigned. See LOAD SWITCH MAPPING DETAIL on sheet 2.

FYA SIGNAL WIRING DETAIL

(wire signal head as shown)

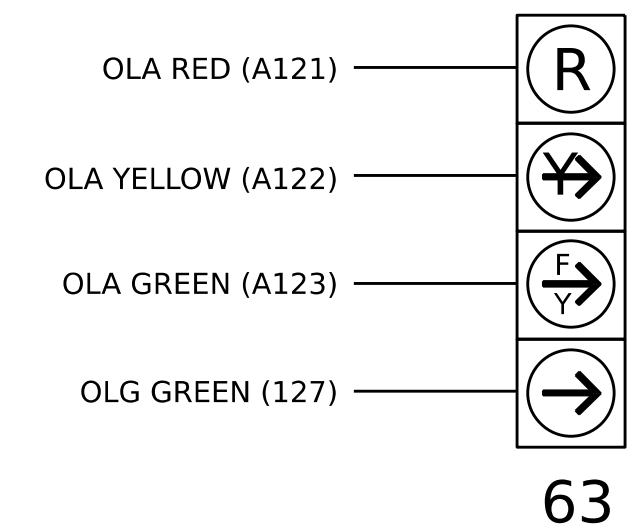

LOAD RESISTOR INSTALLATION DETAIL

(install resistor as shown)

ACCEPTABLE VALUES	
Value (ohms)	Wattage
1.5K - 1.9K	25W (min)
2.0K - 3.0K	10W (min)



THIS ELECTRICAL DETAIL IS FOR THE SIGNAL DESIGN: 12-0309
 DESIGNED: January 2026
 SEALED: 04/13/2026
 REVISED: N/A

Electrical Detail - Sheet 1 of 2

Electrical and Programming Details For:

Prepared in the Offices of:

750 N. Greenfield Pkwy, Garner, NC 27529

I-40 EB Ramp at SR 1007 (Lenoir Rhyne Blvd. SE)

Division 12 Catawba County Hickory

PLAN DATE: April 2026 REVIEWED BY:

PREPARED BY: Tim Langston REVIEWED BY:

REVISIONS	INIT.	DATE

DOCUMENT NOT CONSIDERED FINAL UNLESS ALL SIGNATURES COMPLETED

SEAL

DocuSigned by: Todd Joyce 04/14/2026

SIG. INVENTORY NO. 12-0309