

09_08/2019

See Sheet 1A For Index of Sheets
See Sheet 1B For Conventional Plan Sheet Symbols

STATE OF NORTH CAROLINA
DIVISION OF HIGHWAYS

PAMLICO COUNTY

**LOCATION: REPLACE BRIDGE NO. 57 OVER DAWSON CREEK
ON SR 1302 (JANIERO RD.)**

TYPE OF WORK: GRADING, DRAINAGE, PAVING, AND STRUCTURE

STATE	STATE PROJECT REFERENCE NO.	SHEET NO.	TOTAL SHEETS
N.C.	B-5995	1	
STATE PROJ. NO.	F.A. PROJ. NO.	DESCRIPTION	
48190.1.1	BRZ-1302(083)	PE	
48190.2.1	BRZ-1302(083)	ROW/UTIL	
48190.3.1	BRZ-1302(083)	CONSTRUCTION	

TIP PROJECT: B-5995

CONTRACT: C204742

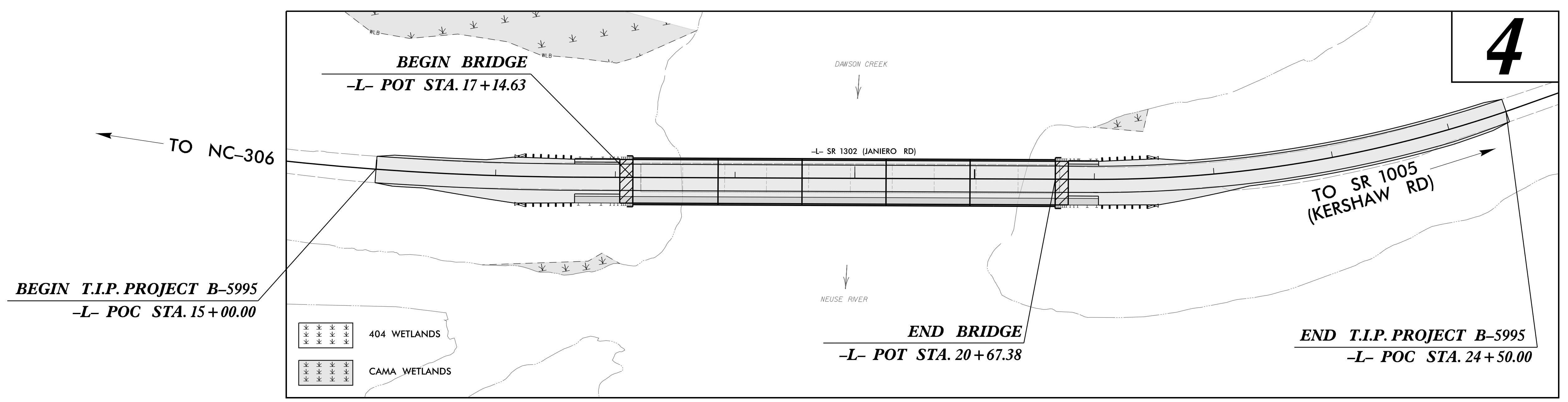
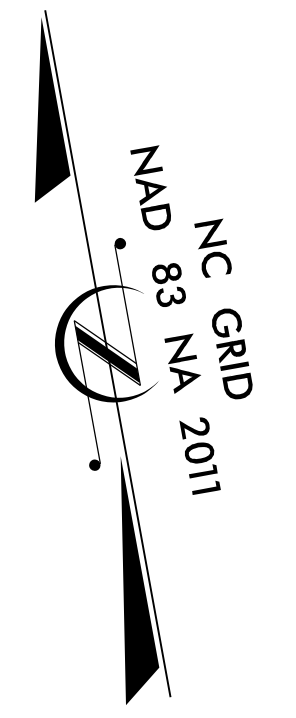
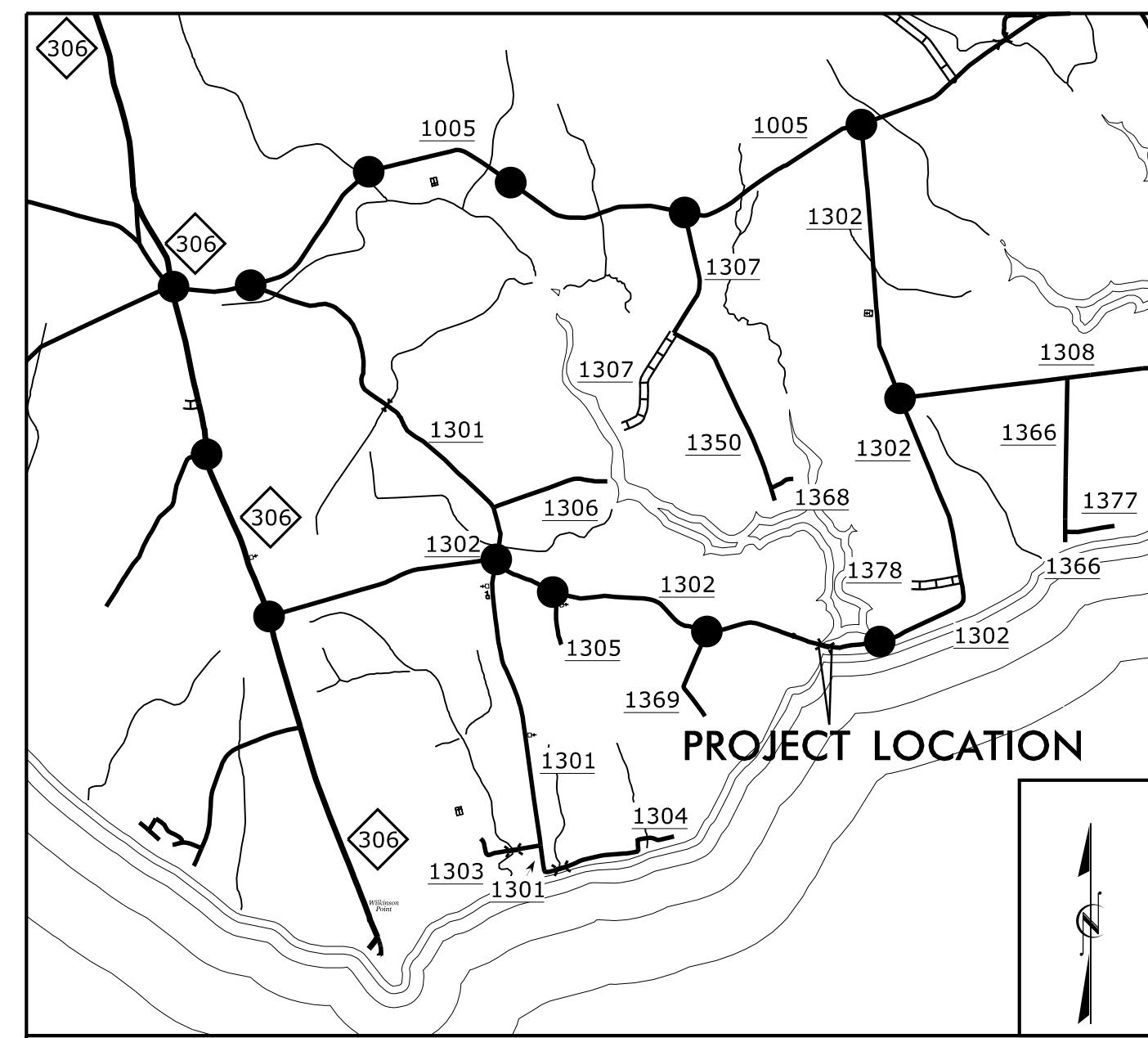

DOCUMENT NOT CONSIDERED FINAL
UNLESS ALL SIGNATURES COMPLETED

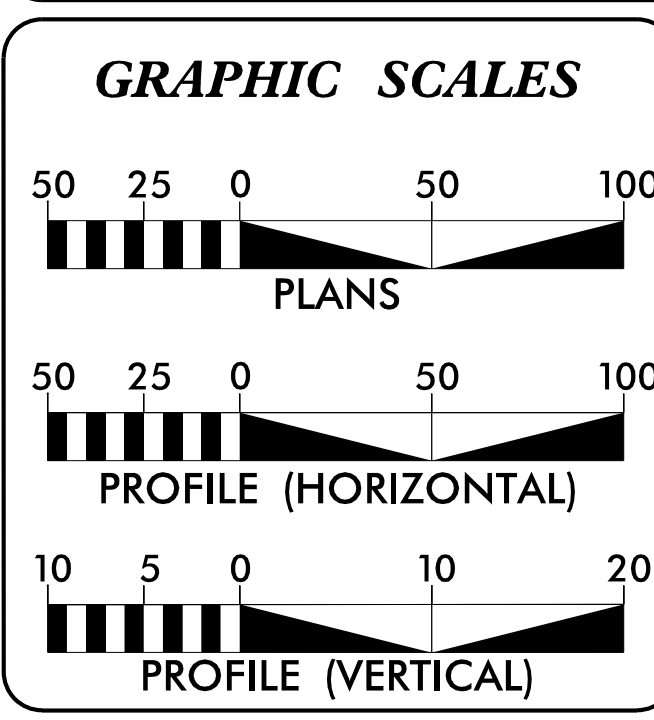

DESIGN DATA

ADT 2026 =	400
ADT 2046 =	800
K =	10 %
D =	60 %
T =	6 % *
V =	50 MPH
* TTST =	2% DUAL 4%
FUNC CLASS =	MINOR COLLECTOR
SUB REGIONAL TIER	

PROJECT LENGTH

LENGTH OF ROADWAY T.I.P. PROJECT B-5995 =	0.113 MILES
LENGTH OF STRUCTURE T.I.P. PROJECT B-5995 =	0.067 MILES
TOTAL LENGTH OF T.I.P. PROJECT B-5995 =	0.180 MILES

PREPARED IN THE OFFICE OF:
HNTB
HNTB NORTH CAROLINA, P.C.
4000 Center at North Hills St
Suite 500
Raleigh, North Carolina 27609
NC License No: C-1554
FOR NCDOT DIVISION 2

2024 STANDARD SPECIFICATIONS

RIGHT OF WAY DATE:
AUGUST 10, 2022

LETTING DATE:
JUNE 16, 2026

ROY H. TELLIER, PE
PROJECT ENGINEER

MICHAEL C. AMAN, PE
NCDOT CONTACT

HYDRAULICS ENGINEER

Signed by: *Paul Cameron*
DATE: 07/20/2022
SIGNATURE:

ROADWAY DESIGN ENGINEER

DocuSigned by: *Roy Tellier*
DATE: 07/20/2022
SIGNATURE:

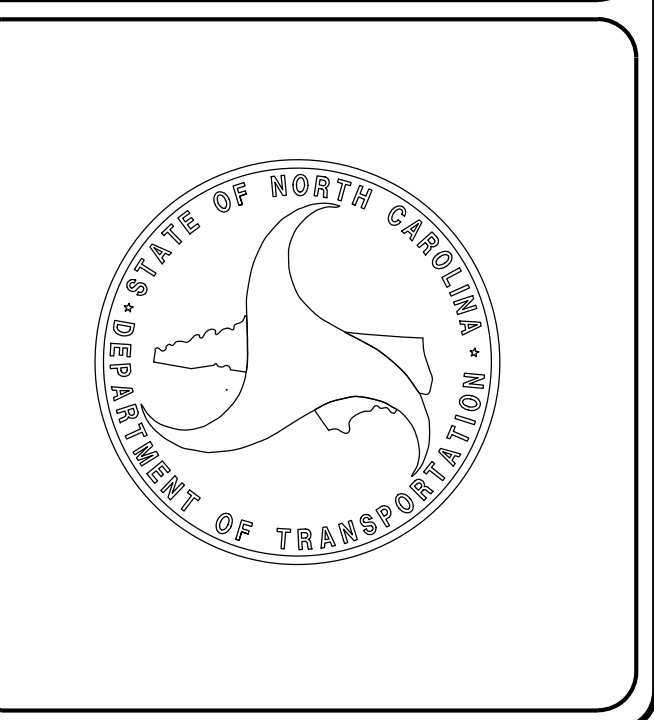

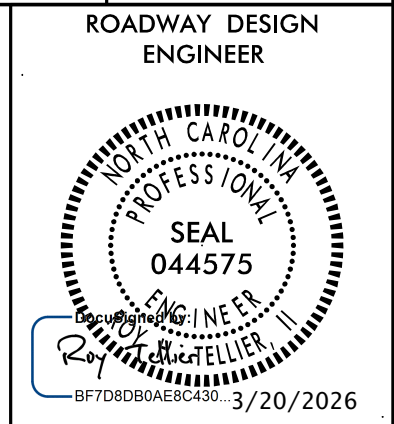

**DOCUMENT NOT CONSIDERED FINAL
UNLESS ALL SIGNATURES COMPLETED**

INDEX OF SHEETS

SHEET NUMBER	SHEET
1	TITLE SHEET
1A	INDEX OF SHEETS, GENERAL NOTES, AND STANDARD DRAWINGS
1B	CONVENTIONAL SYMBOLS
2A-1	PAVEMENT SCHEDULE & TYPICAL SECTIONS
2C-1 THRU 2C-7	SPECIAL DETAILS
3B-1	ROADWAY SUMMARIES
3D-1	DRAINAGE SUMMARIES
3G-1	GEOTECHNICAL SUMMARIES
4	PLAN AND PROFILE SHEET
RW-1 THRU RW-04	SURVEY CONTROL, EXISTING CENTERLINES, RIGHT OF WAY, EASEMENT AND PROPERTY TIES
TMP-1 THRU TMP-2	TRAFFIC MANAGEMENT PLANS
EC-1 THRU EC-5	EROSION CONTROL PLANS
RF-1	REFORESTATION PLANS
UC-1 THRU UC-4	UTILITIES CONSTRUCTION PLANS
UO-1 THRU UO-3	UTILITIES BY OTHERS PLANS
X-1	CROSS-SECTION SUMMARY SHEET
X-2 THRU X-13	CROSS-SECTIONS
S-1 THRU S-25	STRUCTURE PLANS

GENERAL NOTES:

2024 SPECIFICATIONS
 EFFECTIVE: 01-16-2024
 REVISED:

GRADING AND SURFACING OR RESURFACING AND WIDENING:
 THE GRADE LINES SHOWN DENOTE THE FINISHED ELEVATION OF THE PROPOSED SURFACING AT GRADE POINTS SHOWN ON THE TYPICAL SECTIONS. WHERE NO GRADE LINES ARE SHOWN, THE PROFILES SHOWN DENOTE THE TOP ELEVATION OF THE EXISTING PAVEMENT ALONG THE CENTER LINE OF SURVEY ON WHICH THE PROPOSED RESURFACING WILL BE PLACED. GRADE LINES MAY BE ADJUSTED BY THE ENGINEER IN ORDER TO SECURE A PROPER TIE-IN.

CLEARING:
 CLEARING ON THIS PROJECT SHALL BE PERFORMED TO THE LIMITS ESTABLISHED BY METHOD 11.

SUPERELEVATION:
 ALL CURVES ON THIS PROJECT SHALL BE SUPERELEVATED IN ACCORDANCE WITH STD. NO. 225.04 USING THE RATE OF SUPERELEVATION AND RUNOFF SHOWN ON THE PLANS. SUPERELEVATION IS TO BE REVOLVED ABOUT THE GRADE POINTS SHOWN ON THE TYPICAL SECTIONS.

SHOULDER CONSTRUCTION:
 ASPHALT, EARTH, AND CONCRETE SHOULDER CONSTRUCTION ON THE HIGH SIDE OF SUPERELEVATED CURVES SHALL BE IN ACCORDANCE WITH STD. NO. 560.01

SUBSURFACE DRAINS:
 SUBSURFACE DRAINS SHALL BE CONSTRUCTED IN ACCORDANCE WITH STD. NO. 815.02 AT LOCATIONS DIRECTED BY THE ENGINEER.

GUARDRAIL:
 THE GUARDRAIL LOCATIONS SHOWN ON THE PLANS MAY BE ADJUSTED DURING CONSTRUCTION AS DIRECTED BY THE ENGINEER. THE CONTRACTOR SHOULD CONSULT WITH THE ENGINEER PRIOR TO ORDERING GUARDRAIL MATERIAL.

TEMPORARY SHORING:
 SHORING REQUIRED FOR THE MAINTENANCE OF TRAFFIC WILL BE PAID FOR AS "EXTRA WORK" IN ACCORDANCE WITH SECTION 104-7.

END BENTS:
 THE ENGINEER SHALL CHECK THE STRUCTURE END BENT PLANS, DETAILS, AND CROSS-SECTION PRIOR TO SETTING OF THE SLOPE STAKES FOR THE EMBANKMENT OR EXCAVATION APPROACHING A BRIDGE.

UTILITIES:
 UTILITY OWNERS ON THIS PROJECT ARE
 PHONE - BRIGHTSPEED
 CATV - CHARTER
 POWER - TIDELAND EMC
 WATER - PAMLICO COUNTY WATER
 ANY RELOCATION OF EXISTING UTILITIES WILL BE ACCOMPLISHED BY OTHERS, EXCEPT AS SHOWN ON THE PLANS.

RIGHT-OF-WAY MARKERS:
 ALL RIGHT-OF-WAY MARKERS ON THIS PROJECT SHALL BE PLACED BY OTHERS.

2024 ROADWAY ENGLISH STANDARD DRAWINGS

The following Roadway Standards as appear in "Roadway Standard Drawings" Contracts Standards and Development Unit - N. C. Department of Transportation - Raleigh, N. C., Dated January 16, 2024 are applicable to this project and by reference hereby are considered a part of these plans:

STD.NO.	TITLE
DIVISION 2 - EARTHWORK	
200.02	Method of Clearing - Method 11
225.02	Guide for Grading Subgrade - Secondary and Local
225.04	Method of Obtaining Superelevation - Two Lane Pavement
275.01	Rock Plating
DIVISION 3 - PIPE CULVERTS	
300.01	Method of Pipe Installation (Use Details in Lieu of Standards for Sheets 1 and 2 of 2)
DIVISION 4 - MAJOR STRUCTURES	
423.01	Bridge Approach Fills - Type 1 Approach Fill for Bridge Abutment
DIVISION 5 - SUBGRADE, BASES AND SHOULDERS	
560.01	Method of Shoulder Construction - High Side of Superelevated Curve - Method 1
DIVISION 6 - ASPHALT BASES AND PAVEMENTS	
654.01	Pavement Repairs
DIVISION 8 - INCIDENTALS	
815.02	Subsurface Drain
840.00	Concrete Base Pad for Drainage Structures
840.01	Brick Catch Basin - 12" thru 54" Pipe
840.02	Concrete Catch Basin - 12" thru 54" Pipe
840.03	Frame, Grates and Hood - for Use on Standard Catch Basin
840.25	Anchorage for Frames - Brick or Concrete or Precast
840.29	Frames and Narrow Slot Flat Grates
840.34	Traffic Bearing Junction Box - for Use with Pipes 42" and Under
840.35	Traffic Bearing Grated Drop Inlet - for Cast Iron Double Frame and Grates
840.45	Precast Drainage Structure
840.46	Traffic Bearing Precast Drainage Structure
840.54	Manhole Frame and Cover
840.66	Drainage Structure Steps
846.01	Concrete Curb, Gutter and Curb & Gutter
846.04	Drop Inlet Installation in Shoulder Berm Gutter
848.01	Concrete Sidewalk (Use Detail in Lieu of Standard for Sheet 1 of 1)
862.01	Guardrail Placement (Use Details in Lieu of Standards for Sheets 4, 6, 11, 12, and 14 of 15)
862.02	Guardrail Installation (Use Detail in Lieu of Standard for Sheet 5 of 9)
862.03	Structure Anchor Units (Use Detail in Lieu of Standards for Sheet 6 and 8 of 9)
876.02	Guide for Rip Rap at Pipe Outlets

STATE OF NORTH CAROLINA, DIVISION OF HIGHWAYS CONVENTIONAL PLAN SHEET SYMBOLS

Note: Not to Scale

BOUNDARIES AND PROPERTY:

State Line	-----
County Line	-----
Township Line	-----
City Line	-----
Reservation Line	-----
Property Line	-----
Existing Iron Pin (EIP)	○
Computed Property Corner	×
Existing Concrete Monument (ECM)	□
Parcel/Sequence Number	(123)
Existing Fence Line	-x-x-x-
Proposed Woven Wire Fence	○
Proposed Chain Link Fence	□
Proposed Barbed Wire Fence	◇
Existing Wetland Boundary	WLB
Proposed Wetland Boundary	WLB
Existing Endangered Animal Boundary	EAB
Existing Endangered Plant Boundary	EPB
Existing Historic Property Boundary	HPB
Known Contamination Area: Soil	☠-s-☠-s-
Potential Contamination Area: Soil	☠-s-☠-s-
Known Contamination Area: Water	☠-w-☠-w-
Potential Contamination Area: Water	☠-w-☠-w-
Contaminated Site: Known or Potential	☠ ?

BUILDINGS AND OTHER CULTURE:

Gas Pump Vent or U/G Tank Cap	○
Sign	○
Well	○
Small Mine	×
Foundation	□
Area Outline	□
Cemetery	□
Building	□
School	□
Church	□
Dam	□

HYDROLOGY:

Stream or Body of Water	-----
Hydro, Pool or Reservoir	-----
Jurisdictional Stream	JS
Buffer Zone 1	BZ 1
Buffer Zone 2	BZ 2
Flow Arrow	←
Disappearing Stream	→
Spring	○
Wetland	WLB
Proposed Lateral, Tail, Head Ditch	-----
False Sump	▽

RAILROADS:

Standard Gauge	-----
RR Signal Milepost	○
Switch	□
RR Abandoned	-----
RR Dismantled	-----

RIGHT OF WAY & PROJECT CONTROL:

Primary Horiz Control Point	○
Primary Horiz and Vert Control Point	●
Secondary Horiz and Vert Control Point	◆
Vertical Benchmark	⊕
Existing Right of Way Monument	△
Proposed Right of Way Monument (Rebar and Cap)	▲
Proposed Right of Way Monument (Concrete)	▲
Existing Permanent Easement Monument	◇
Proposed Permanent Easement Monument (Rebar and Cap)	◆
Existing C/A Monument	△
Proposed C/A Monument (Rebar and Cap)	▲
Proposed C/A Monument (Concrete)	▲
Existing Right of Way Line	-----
Proposed Right of Way Line	-----
Existing Control of Access Line	-----
Proposed Control of Access Line	-----
Proposed ROW and CA Line	-----
Existing Easement Line	-----
Proposed Temporary Construction Easement	E
Proposed Temporary Drainage Easement	TDE
Proposed Permanent Drainage Easement	PDE
Proposed Permanent Drainage/Utility Easement	DUE
Proposed Permanent Utility Easement	PUE
Proposed Temporary Utility Easement	TUE
Proposed Aerial Utility Easement	AUE

ROADS AND RELATED FEATURES:

Existing Edge of Pavement	-----
Existing Curb	-----
Proposed Slope Stakes Cut	C
Proposed Slope Stakes Fill	F
Proposed Curb Ramp	CR
Existing Metal Guardrail	T
Proposed Guardrail	T
Existing Cable Guiderail	□
Proposed Cable Guiderail	□
Equality Symbol	⊕
Pavement Removal	⊗
VEGETATION:	
Single Tree	○
Single Shrub	○
Hedge	-----

Woods Line	-----
Orchard	○
Vineyard	□

EXISTING STRUCTURES:

MAJOR:	
Bridge, Tunnel or Box Culvert	CONC
Bridge Wing Wall, Head Wall and End Wall	CONC WW
MINOR:	
Head and End Wall	CONC HW
Pipe Culvert	-----
Footbridge	-----
Drainage Box: Catch Basin, DI or JB	CB
Paved Ditch Gutter	-----
Storm Sewer Manhole	⊕
Storm Sewer	S

UTILITIES:

* SUE - Subsurface Utility Engineering
LOS - Level of Service - A,B,C or D (Accuracy)

POWER:	
Existing Power Pole	●
Proposed Power Pole	○
Existing Joint Use Pole	●
Proposed Joint Use Pole	○
Power Manhole	⊕
Power Line Tower	⊗
Power Transformer	⊗
U/G Power Cable Hand Hole	PH
H-Frame Pole	●
U/G Power Line Test Hole (SUE - LOS A)*	⊕
U/G Power Line (SUE - LOS B)*	P
U/G Power Line (SUE - LOS C)*	P
U/G Power Line (SUE - LOS D)*	P

TELEPHONE:

Existing Telephone Pole	●
Proposed Telephone Pole	○
Telephone Manhole	⊕
Telephone Pedestal	⊕
Telephone Cell Tower	⊕
U/G Telephone Cable Hand Hole	PH
U/G Telephone Test Hole (SUE - LOS A)*	⊕
U/G Telephone Cable (SUE - LOS B)*	T
U/G Telephone Cable (SUE - LOS C)*	T
U/G Telephone Cable (SUE - LOS D)*	T
U/G Telephone Conduit (SUE - LOS B)*	TC
U/G Telephone Conduit (SUE - LOS C)*	TC
U/G Telephone Conduit (SUE - LOS D)*	TC
U/G Fiber Optics Cable (SUE - LOS B)*	T FO
U/G Fiber Optics Cable (SUE - LOS C)*	T FO
U/G Fiber Optics Cable (SUE - LOS D)*	T FO

WATER:

Water Manhole	⊕
Water Meter	○
Water Valve	⊗
Water Hydrant	⊕
U/G Water Line Test Hole (SUE - LOS A)*	⊕
U/G Water Line (SUE - LOS B)*	P
U/G Water Line (SUE - LOS C)*	P
U/G Water Line (SUE - LOS D)*	P
Above Ground Water Line	A/G Water
TV:	
TV Pedestal	⊕
TV Tower	⊗
U/G TV Cable Hand Hole	PH
U/G TV Test Hole (SUE - LOS A)*	⊕
U/G TV Cable (SUE - LOS B)*	TV
U/G TV Cable (SUE - LOS C)*	TV
U/G TV Cable (SUE - LOS D)*	TV
U/G Fiber Optic Cable (SUE - LOS B)*	TV FO
U/G Fiber Optic Cable (SUE - LOS C)*	TV FO
U/G Fiber Optic Cable (SUE - LOS D)*	TV FO

GAS:

Gas Valve	◇
Gas Meter	⊕
U/G Gas Line Test Hole (SUE - LOS A)*	⊕
U/G Gas Line (SUE - LOS B)*	G
U/G Gas Line (SUE - LOS C)*	G
U/G Gas Line (SUE - LOS D)*	G
Above Ground Gas Line	A/G Gas

SANITARY SEWER:

Sanitary Sewer Manhole	⊕
Sanitary Sewer Cleanout	⊕
U/G Sanitary Sewer Line	SS
Above Ground Sanitary Sewer	A/G Sanitary Sewer
SS Force Main Line Test Hole (SUE - LOS A)*	⊕
SS Force Main Line (SUE - LOS B)*	FSS
SS Force Main Line (SUE - LOS C)*	FSS
SS Force Main Line (SUE - LOS D)*	FSS

MISCELLANEOUS:

Utility Pole	●
Utility Pole with Base	□
Utility Located Object	○
Utility Traffic Signal Box	⊕
Utility Unknown U/G Line (SUE - LOS B)*	UTL
U/G Tank; Water, Gas, Oil	UST
Underground Storage Tank, Approx. Loc.	UST
A/G Tank; Water, Gas, Oil	UST
Geoenvironmental Boring	⊕
Abandoned According to Utility Records	AATUR
End of Information	E.O.I.

6/2/2019

PAVEMENT SCHEDULE	
(FINAL PAVEMENT DESIGN DATED: 01/20/2026)	
C1	PROP. APPROX. 1.5" ASPHALT CONCRETE SURFACE COURSE TYPE S9.5B AT AN AVERAGE RATE OF 165 LBS. PER SQ. YD.
C2	PROP. APPROX. 3" ASPHALT CONCRETE SURFACE COURSE, TYPE S9.5B, AT AN AVERAGE RATE OF 165 LBS. PER SQ. YD. PLACED IN EACH OF TWO LAYERS.
C3	PROP. VAR. DEPTH ASPHALT CONCRETE SURFACE COURSE TYPE S9.5B, AT AN AVERAGE RATE OF 110 LBS. PER SQ. YD. PER 1" DEPTH, TO BE PLACED IN LAYERS NOT LESS THAN 1" IN DEPTH OR GREATER THAN 1 1/2" IN DEPTH.
D1	PROP. APPROX. 4" ASPHALT CONCRETE INTERMEDIATE COURSE, TYPE I19.0C, AT AN AVERAGE RATE OF 456 LBS. PER SQ. YD.
D2	PROP. VAR. DEPTH ASPHALT CONCRETE INTERMEDIATE COURSE, TYPE I19.0C, AT AN AVERAGE RATE OF 114 LBS. PER SQ. YD. PER 1" DEPTH, TO BE PLACED IN LAYERS NOT LESS THAN 2 1/2" IN DEPTH OR GREATER THAN 4" IN DEPTH.
E1	PROP. APPROX. 4" ASPHALT CONCRETE BASE COURSE, TYPE B25.0C, AT AN AVERAGE RATE OF 456 LBS. PER SQ. YD.
E2	PROP. VAR. DEPTH ASPHALT CONCRETE BASE COURSE, TYPE B25.0C, AT AN AVERAGE RATE OF 114 LBS. PER SQ. YD. PER 1" DEPTH, TO BE PLACED IN LAYERS NOT LESS THAN 3" IN DEPTH OR GREATER THAN 5 1/2" IN DEPTH.
R1	2'-6" CONCRETE CURB & GUTTER
R2	SHOULDER BERM GUTTER
S1	4" CONCRETE SIDEWALK
T	EARTH MATERIAL.
U	EXISTING PAVEMENT.
V	INCIDENTAL MILLING
W	VARIABLE DEPTH ASPHALT PAVEMENT (SEE WEDGING DETAIL, THIS SHEET)

NOTE: PAVEMENT EDGE SLOPES ARE 1:1 UNLESS OTHERWISE SHOWN.

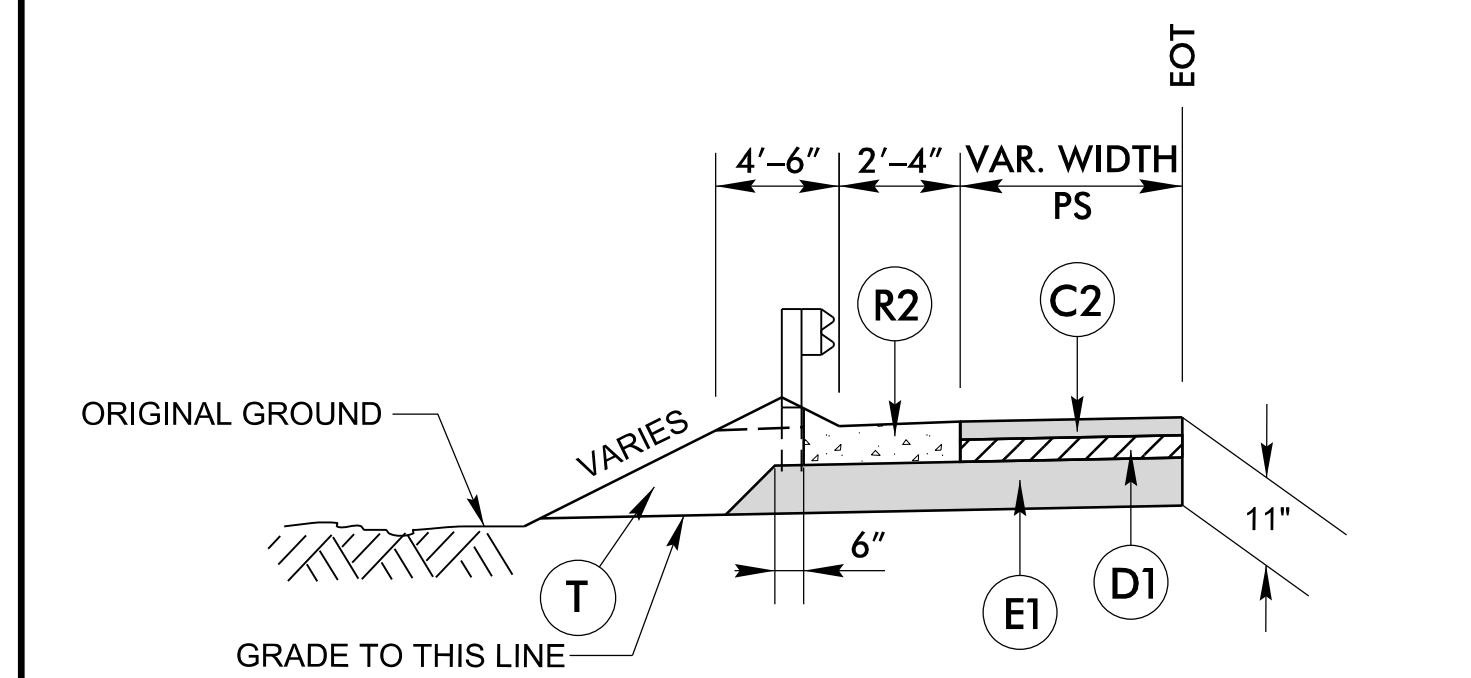

SHOULDER BERM GUTTER DETAIL
 USE DETAIL WITH TYPICAL SECTION NO. 2
 -L- STA 16+66.01 LT TO STA 17+03.75 LT
 -L- STA 20+78.25 LT TO STA 21+03.57 LT

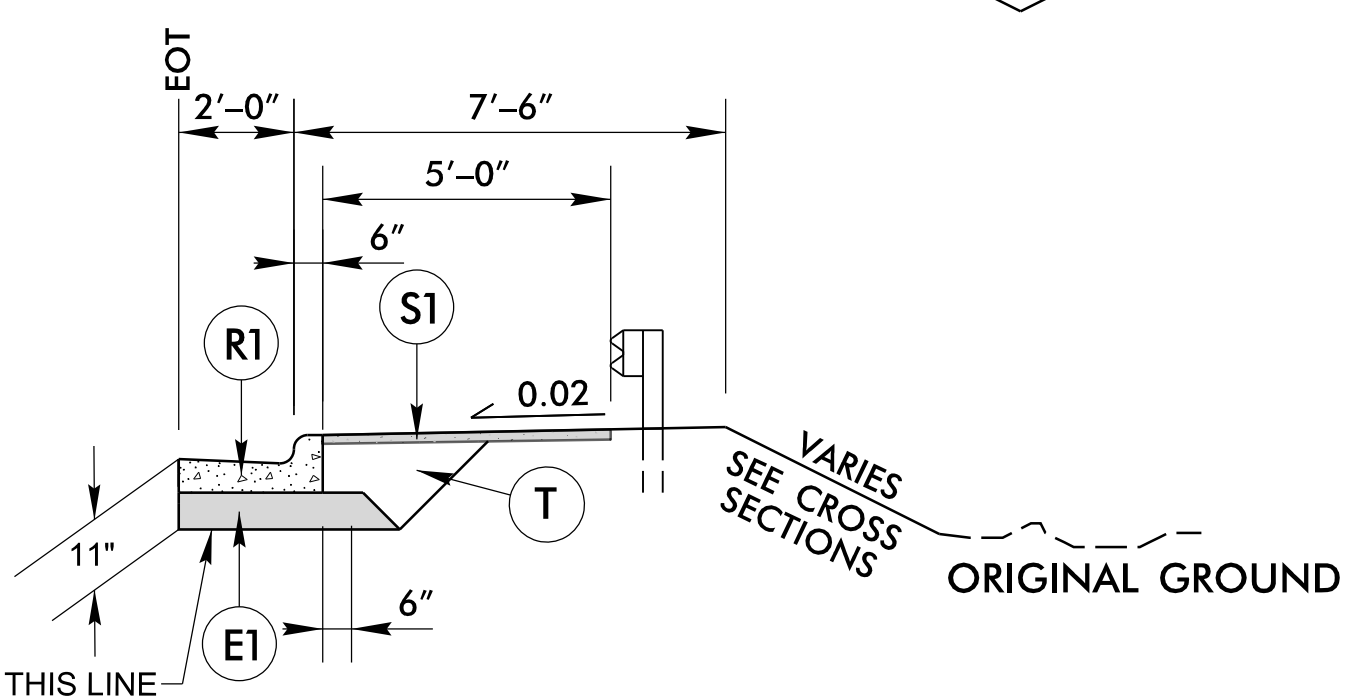

CURB & GUTTER DETAIL
 USE DETAIL WITH TYPICAL SECTION NO. 2
 -L- STA 16+66.01 RT TO STA 17+03.75 RT
 -L- STA 20+78.25 RT TO STA 21+03.42 RT

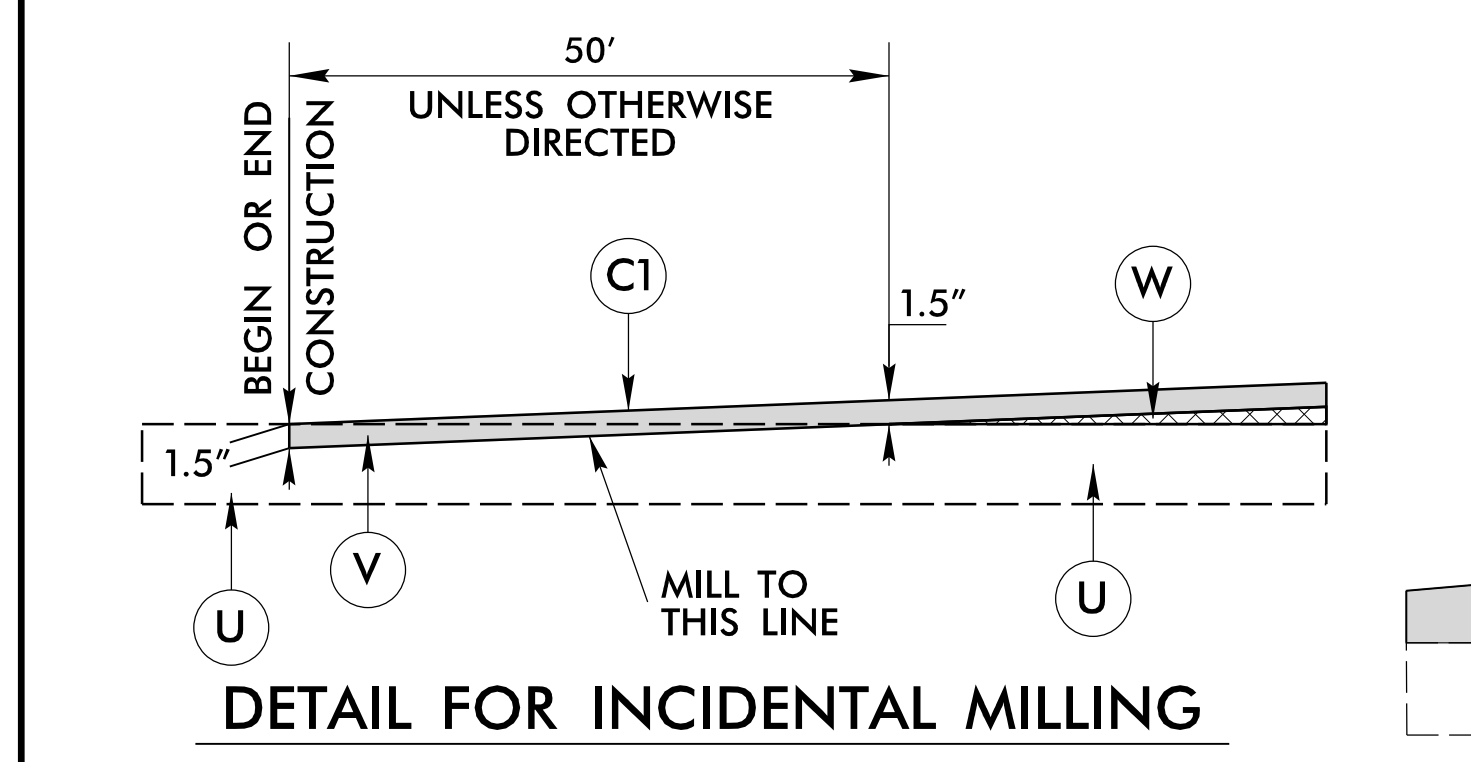

DETAIL FOR INCIDENTAL MILLING

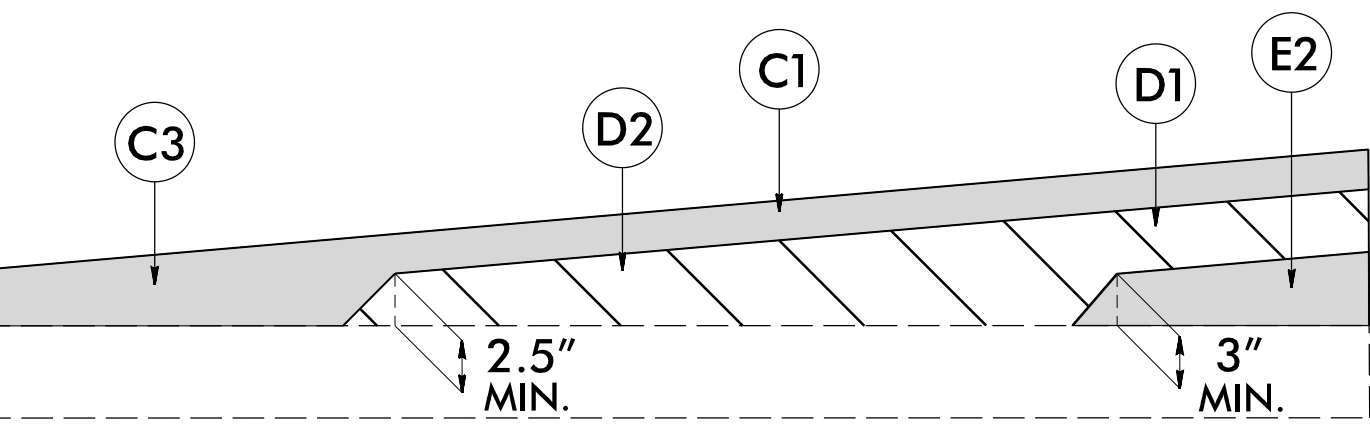

DETAIL FOR WEDGING

HNTB HNTB NORTH CAROLINA, P.C.
 4000 Center at North Hills St
 Suite 500
 Raleigh, North Carolina 27609
 NC License No: C-1554

PROJECT REFERENCE NO. B-5995	SHEET NO. 2A-1
ROADWAY DESIGN ENGINEER <i>[Signature]</i>	PAVEMENT DESIGN ENGINEER <i>[Signature]</i>
SEAL 044575 3/19/2026	SEAL 038176 3/20/2026

DOCUMENT NOT CONSIDERED FINAL UNLESS ALL SIGNATURES COMPLETED

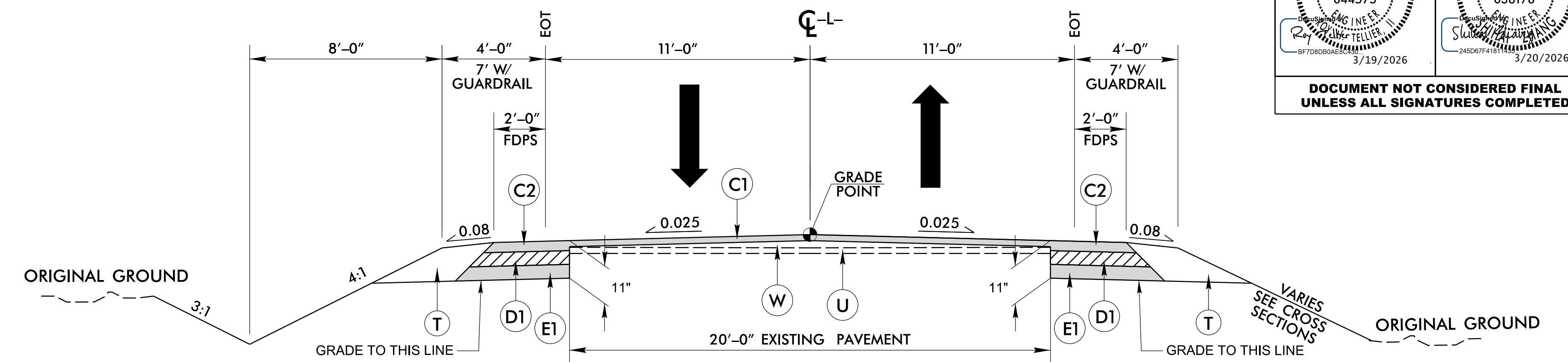

TYPICAL SECTION NO. 1
 -L- SR 1302 (JANIERO RD)

USE TYPICAL SECTION NO. 1 FROM:
 -L- STA 15+00.00 TO STA 16+00.00
 -L- STA 21+50.00 TO STA 24+50.00

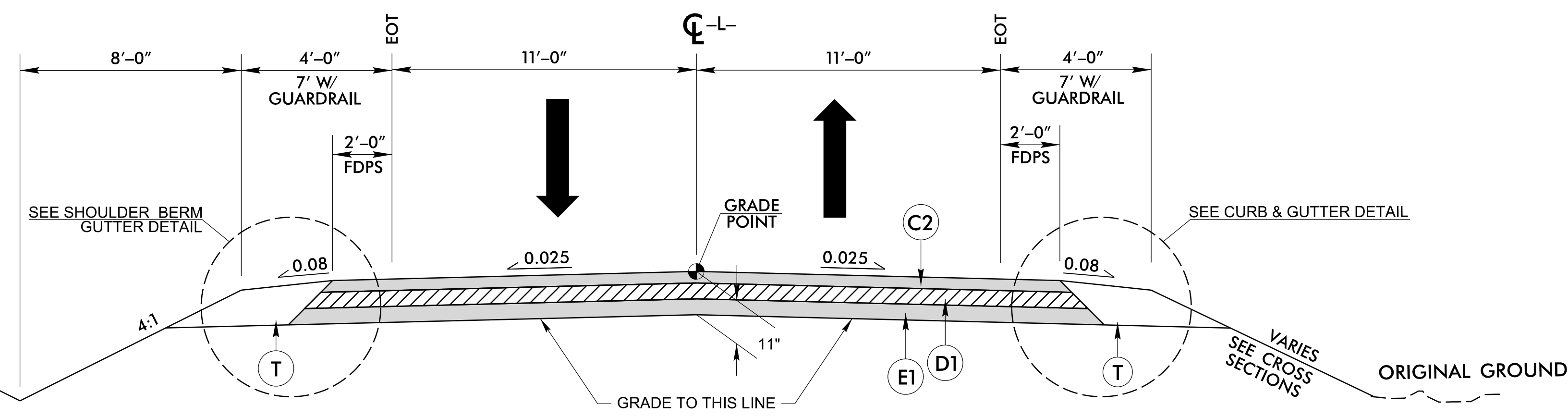

TYPICAL SECTION NO. 2
 -L- SR 1302 (JANIERO RD)

USE TYPICAL SECTION NO. 2 FROM:
 -L- STA 16+00.00 TO STA 17+14.63 (BRIDGE)
 -L- STA 20+67.38 (BRIDGE) TO STA 21+50.00

NOTES:
 GUARDRAIL TO BE PLACED AT MINIMUM 4' FROM EDGE OF TRAVEL.

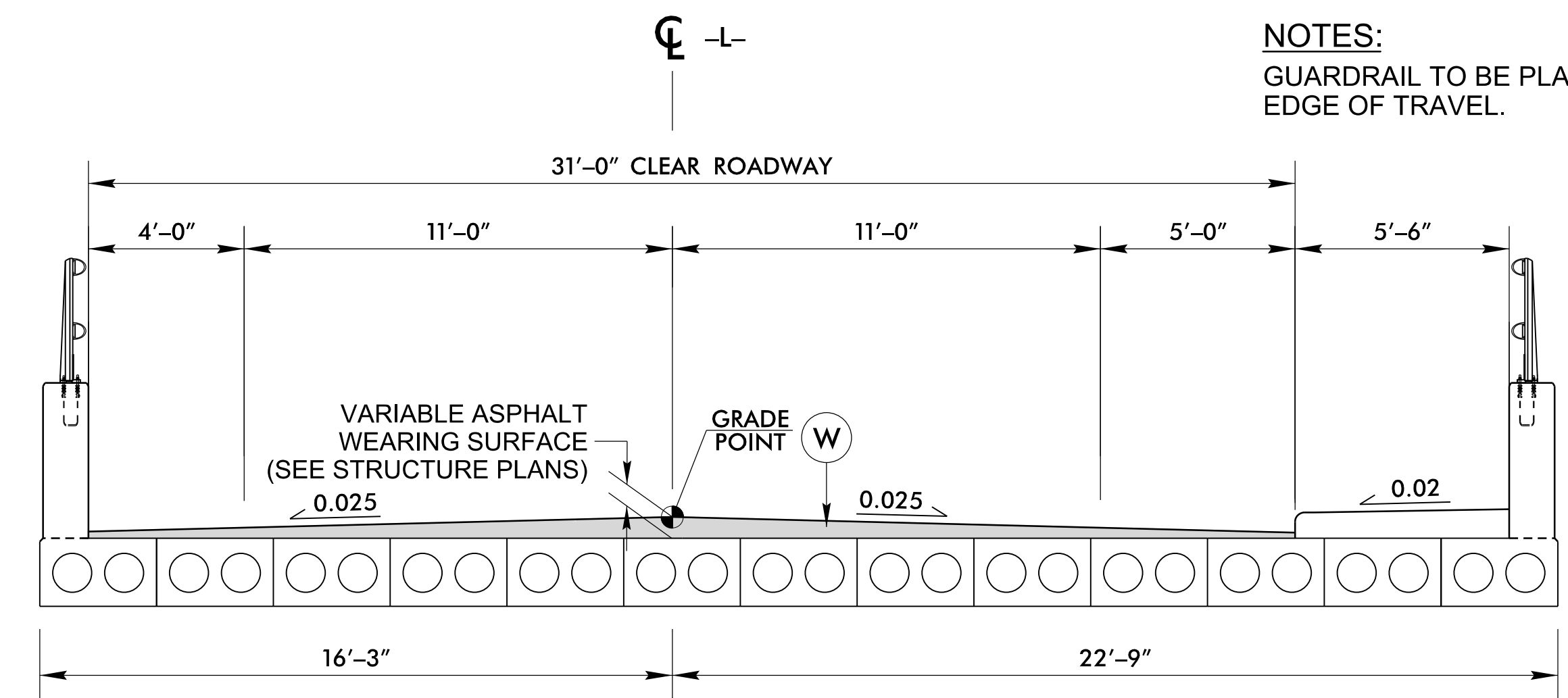

TYPICAL SECTION NO. 3
 -L- SR 1302 (JANIERO RD)
 CORED SLAB BRIDGE

USE TYPICAL SECTION NO. 3 FROM:
 -L- STA 17+14.63 TO STA 20+67.38

SEE STRUCTURES PLANS FOR STRUCTURE CONSTRUCTION DETAILS

19-MAR-2026 12:51
 V:\Projects\2025\185995\RDY_TYP.dgn
 HNTB

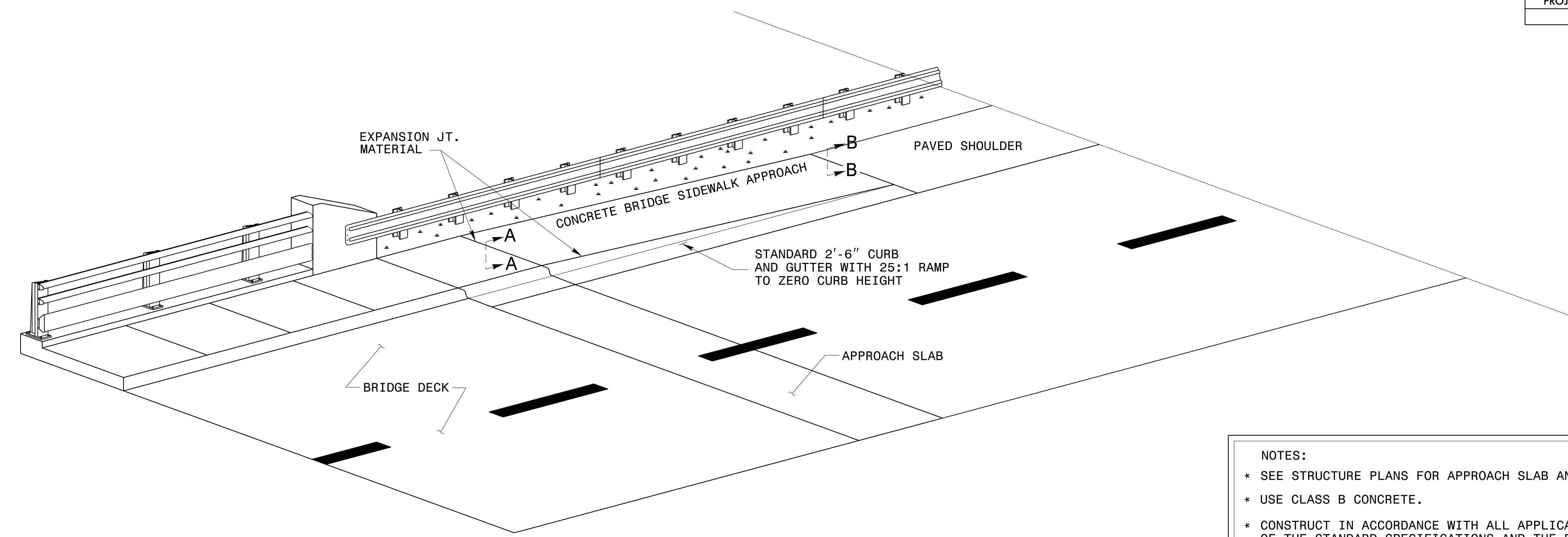

DETAIL OF PROPOSED CONCRETE BRIDGE SIDEWALK APPROACH

- NOTES:**
- * SEE STRUCTURE PLANS FOR APPROACH SLAB AND CURB DIMENSIONS.
 - * USE CLASS B CONCRETE.
 - * CONSTRUCT IN ACCORDANCE WITH ALL APPLICABLE REQUIREMENTS OF THE STANDARD SPECIFICATIONS AND THE ROADWAY DRAWINGS OR AS DIRECTED BY THE ENGINEER.
 - * DETERMINE WIDTH OF PROPOSED BRIDGE SIDEWALK APPROACH IN FIELD TO MATCH WALKWAY ON BRIDGE AND APPROACH SLAB OR AS DIRECTED BY THE ENGINEER.
 - * SEE ROADWAY PLANS FOR GUARDRAIL PLACEMENT.

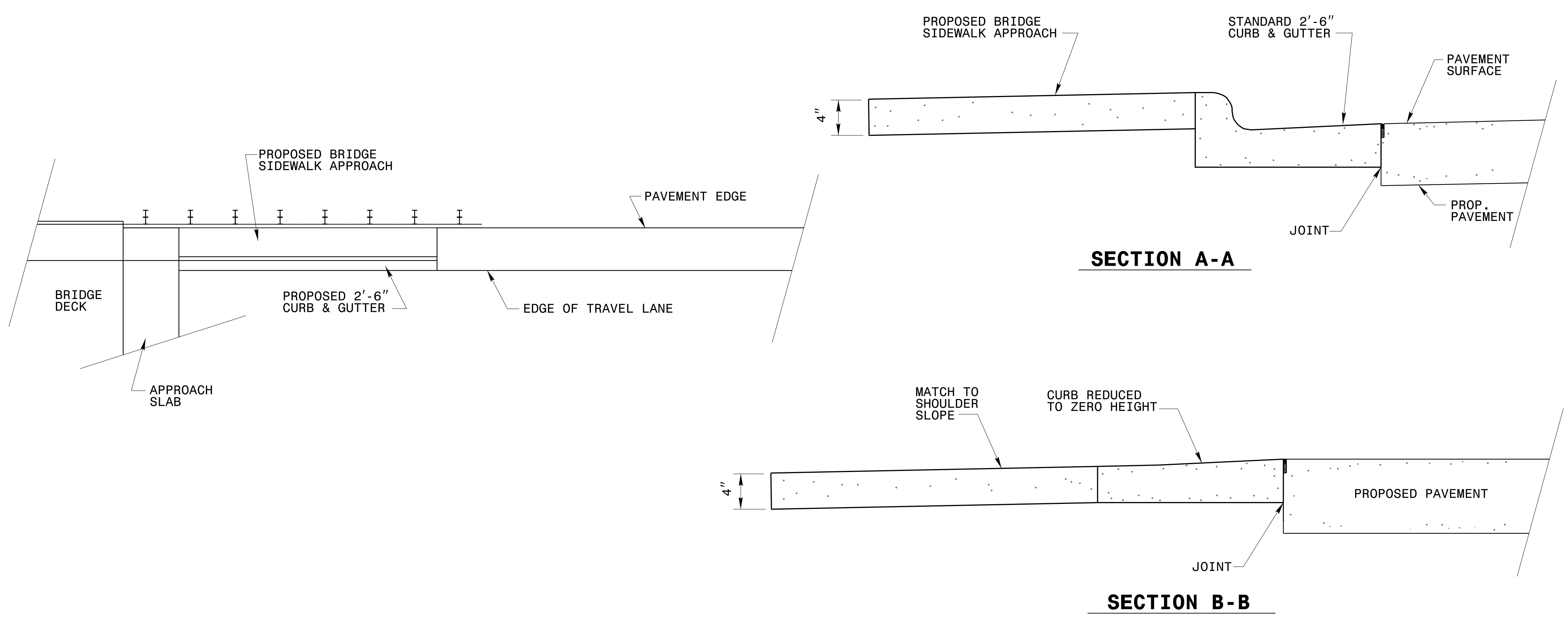

DOCUMENT NOT CONSIDERED FINAL
UNLESS ALL SIGNATURES COMPLETED

**CONTRACT STANDARDS & DEVELOPMENT UNIT
STANDARDS AND SPECIAL DESIGN**
Office 919-707-6950 FAX 919-250-4119



**DETAIL OF CONCRETE BRIDGE
SIDEWALK APPROACH**

ORIGINAL BY: _____ DATE: _____
 MODIFIED BY: rnbritt DATE: 10-12-04
 CHECKED BY: _____ DATE: _____
 FILE SPEC.: details/nbritt/metric/misc/sidewalkapproach.dgn

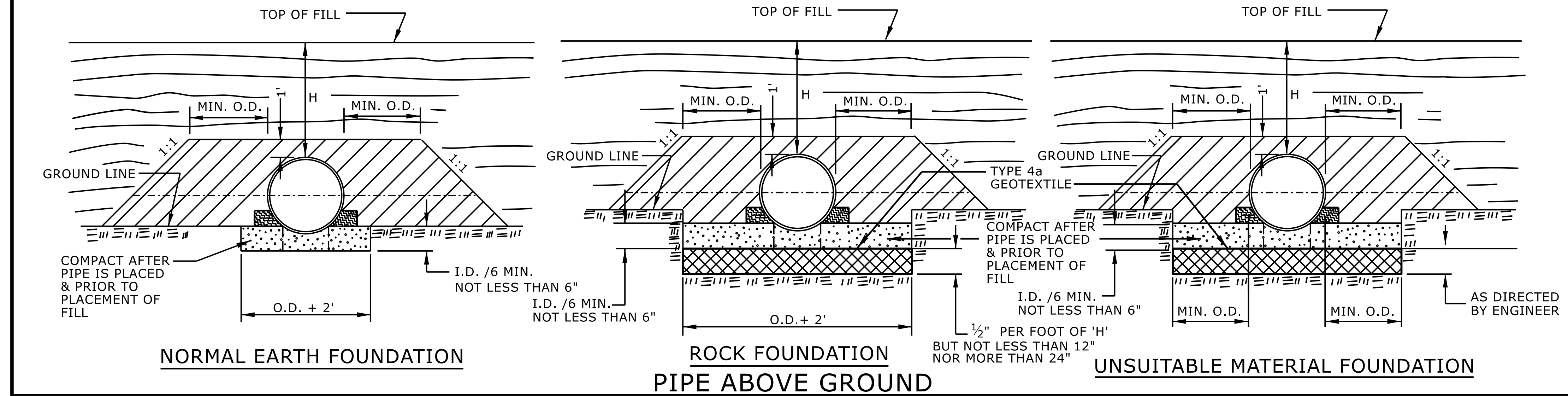
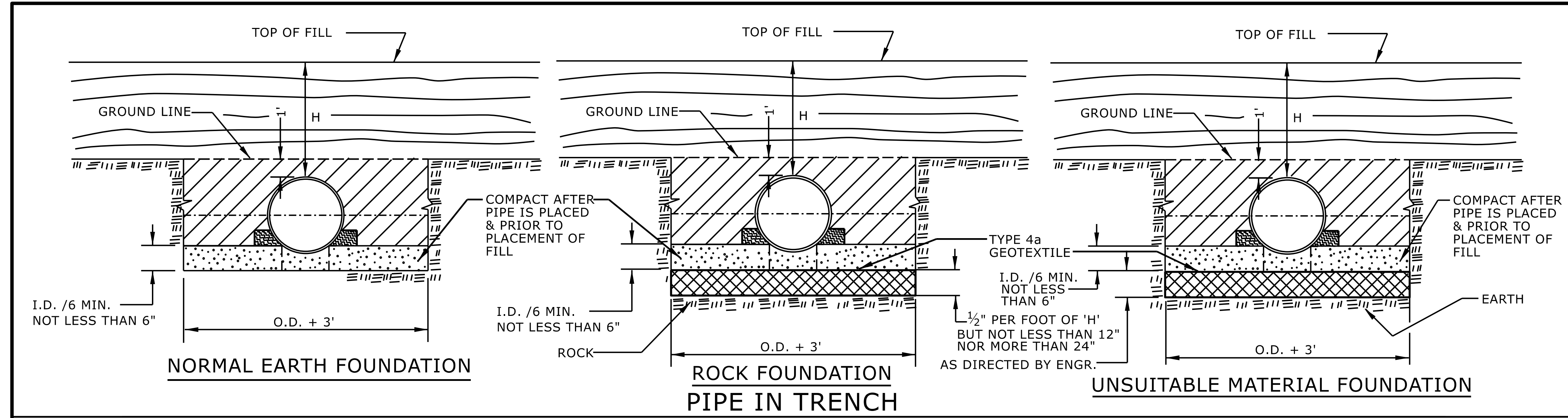



Q:\FEB-2019\1431\Projects\Special Details\Jhowerton\Bridge Approach Sidewalk Transition.dgn
 Jhowerton At CSD 2/25/26

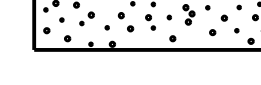

GENERAL NOTES:
 I.D. = THE MAXIMUM HORIZONTAL INSIDE DIAMETER DIMENSION.
 O.D. = THE MAXIMUM HORIZONTAL OUTSIDE DIAMETER DIMENSION.
 H = THE FILL HEIGHT MEASURED VERTICALLY AT ANY POINT ALONG THE PIPE FROM THE TOP OF THE PIPE TO THE TOP OF THE EMBANKMENT AT THAT POINT.

-  APPROVED SUITABLE LOCAL MATERIAL.
-  TAKE CARE TO FULLY COMPACT HAUNCH ZONE OF PIPE BACKFILL.
-  LOOSELY PLACED SELECT MATERIAL CLASS III OR CLASS II, TYPE 1 FOR PIPE BEDDING. LEAVE SECTION DIRECTLY BENEATH PIPE UNCOMPACTED AS PIPE SEATING AND BACKFILL WILL ACCOMPLISH COMPACTION.

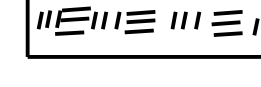
DO NOT OPERATE HEAVY EQUIPMENT OVER ANY PIPE CULVERT UNTIL THE PIPE CULVERT HAS BEEN PROPERLY BACKFILLED AND COVERED WITH AT LEAST 3 FEET OF APPROVED MATERIAL.
 REFER TO NCDOT PIPE MATERIAL SELECTION GUIDE AND STANDARD SPECIFICATIONS FOR ALLOWABLE PIPE FILL HEIGHTS AND PIPE SPECIFICATIONS.

-  SPRINGLINE OF PIPE
-  SELECT BACKFILL MATERIAL CLASS III OR CLASS II, TYPE 1 ABOVE AND BELOW SPRINGLINE.
-  UNDISTURBED EARTH MATERIAL
-  SELECT MATERIAL CLASS V OR VI FOR FOUNDATION CONDITIONING. ENCAPSULATE WITH TYPE IV GEOTEXTILE AS DIRECTED BY THE ENGINEER.

STATE OF NORTH CAROLINA
 DEPT. OF TRANSPORTATION
 DIVISION OF HIGHWAYS
 RALEIGH, N.C.

ROADWAY DETAIL DRAWING FOR
METHOD OF PIPE INSTALLATION
 FLEXIBLE PIPE



SHEET 1 OF 2
300.01

DOCUMENT NOT CONSIDERED FINAL
 UNLESS ALL SIGNATURES COMPLETED



CONTRACTS STANDARDS AND DEVELOPMENT UNIT
 Office 919-707-6950 FAX 919-250-4119

SEE TITLE BLOCK

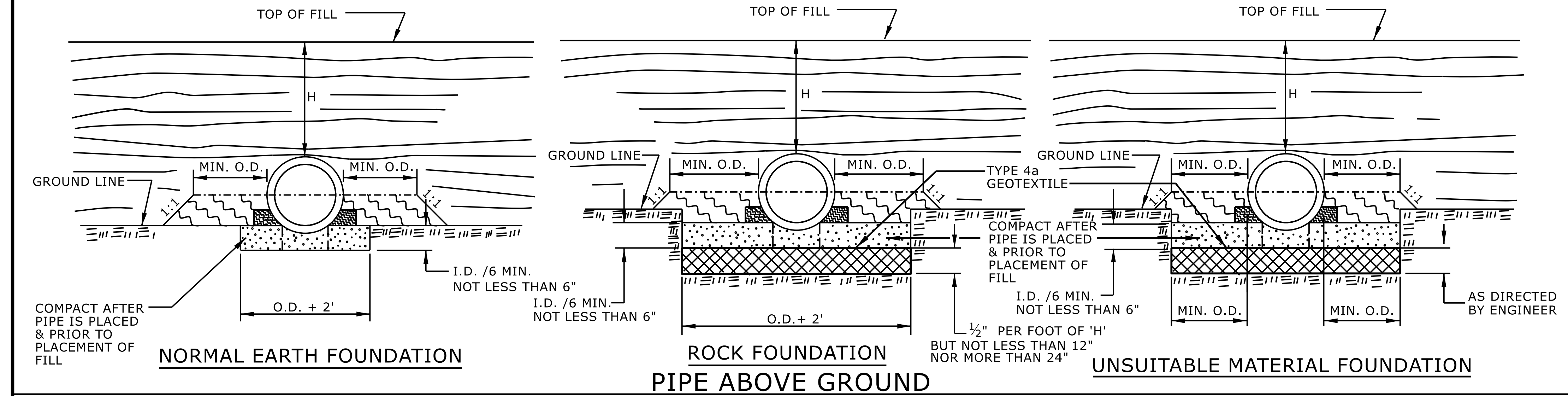
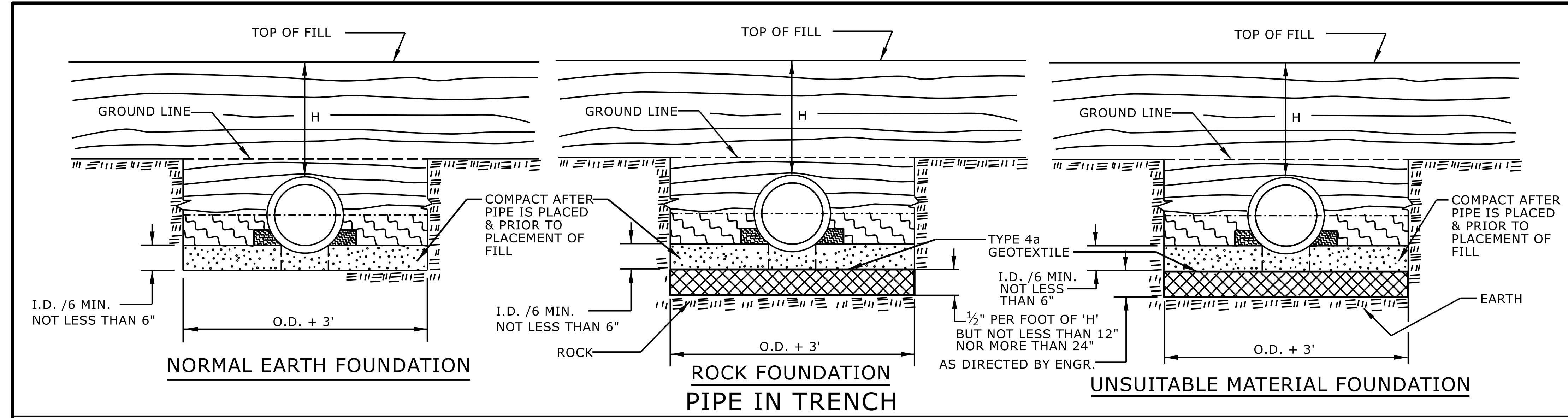
ORIGINAL BY: S.CALHOUN DATE: 7-25-2024
 MODIFIED BY: DATE: _____
 CHECKED BY: DATE: _____
 FILE SPEC.: _____





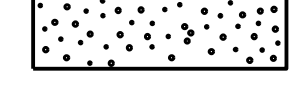

GENERAL NOTES:
 I.D. = THE MAXIMUM HORIZONTAL INSIDE DIAMETER DIMENSION.
 O.D. = THE MAXIMUM HORIZONTAL OUTSIDE DIAMETER DIMENSION.
 H = THE FILL HEIGHT MEASURED VERTICALLY AT ANY POINT ALONG THE PIPE FROM THE TOP OF THE PIPE TO THE TOP OF THE EMBANKMENT AT THAT POINT.

-  APPROVED SUITABLE LOCAL MATERIAL.
-  TAKE CARE TO FULLY COMPACT HAUNCH ZONE OF PIPE BACKFILL.
-  LOOSELY PLACED SELECT MATERIAL CLASS III OR CLASS II, TYPE 1 FOR PIPE BEDDING. LEAVE SECTION DIRECTLY BENEATH PIPE UNCOMPACTED AS PIPE SEATING AND BACKFILL WILL ACCOMPLISH COMPACTION.

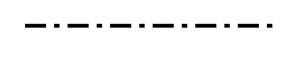
DO NOT OPERATE HEAVY EQUIPMENT OVER ANY PIPE CULVERT UNTIL THE PIPE CULVERT HAS BEEN PROPERLY BACKFILLED AND COVERED WITH AT LEAST 3 FEET OF APPROVED MATERIAL.

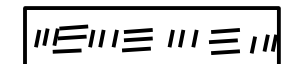
REFER TO NCDOT PIPE MATERIAL SELECTION GUIDE AND STANDARD SPECIFICATIONS FOR ALLOWABLE PIPE FILL HEIGHTS AND PIPE SPECIFICATIONS.

-  SPRINGLINE OF PIPE
-  SELECT BACKFILL MATERIAL CLASS III OR CLASS II, BELOW SPRINGLINE.
-  UNDISTURBED EARTH MATERIAL
-  SELECT MATERIAL CLASS V OR VI FOR FOUNDATION CONDITIONING. ENCAPSULATE WITH TYPE IV GEOTEXTILE AS DIRECTED BY THE ENGINEER.

STATE OF NORTH CAROLINA
 DEPT. OF TRANSPORTATION
 DIVISION OF HIGHWAYS
 RALEIGH, N.C.

ROADWAY DETAIL DRAWING FOR
METHOD OF PIPE INSTALLATION
 RIGID PIPE

SHEET 2 OF 2
300.01



DOCUMENT NOT CONSIDERED FINAL
 UNLESS ALL SIGNATURES COMPLETED

CONTRACTS STANDARDS
 AND DEVELOPMENT UNIT
 Office 919-707-6950 FAX 919-250-4119

SEE TITLE BLOCK

ORIGINAL BY: S.CALHOUN DATE: 7-25-2024
 MODIFIED BY: DATE:
 CHECKED BY: DATE:
 FILE SPEC.:

NOTES:

CONSTRUCT STANDARD SIDEWALK 5' WIDE AND 4" THICK UNLESS OTHERWISE DENOTED ON PLANS.

PLACE A GROOVE JOINT 1" DEEP WITH 1/8" RADII IN THE CONCRETE SIDEWALK AT 5' INTERVALS. ONE 1/2" EXPANSION JOINT WILL BE REQUIRED AT 50' INTERVALS. A 1/2" EXPANSION JOINT WILL BE REQUIRED WHERE THE SIDEWALK JOINS ANY RIGID STRUCTURE.

SEE STD. DWG. 848.06 FOR CURB RAMP LOCATION REQUIREMENTS AND CONSTRUCTION GUIDELINES.

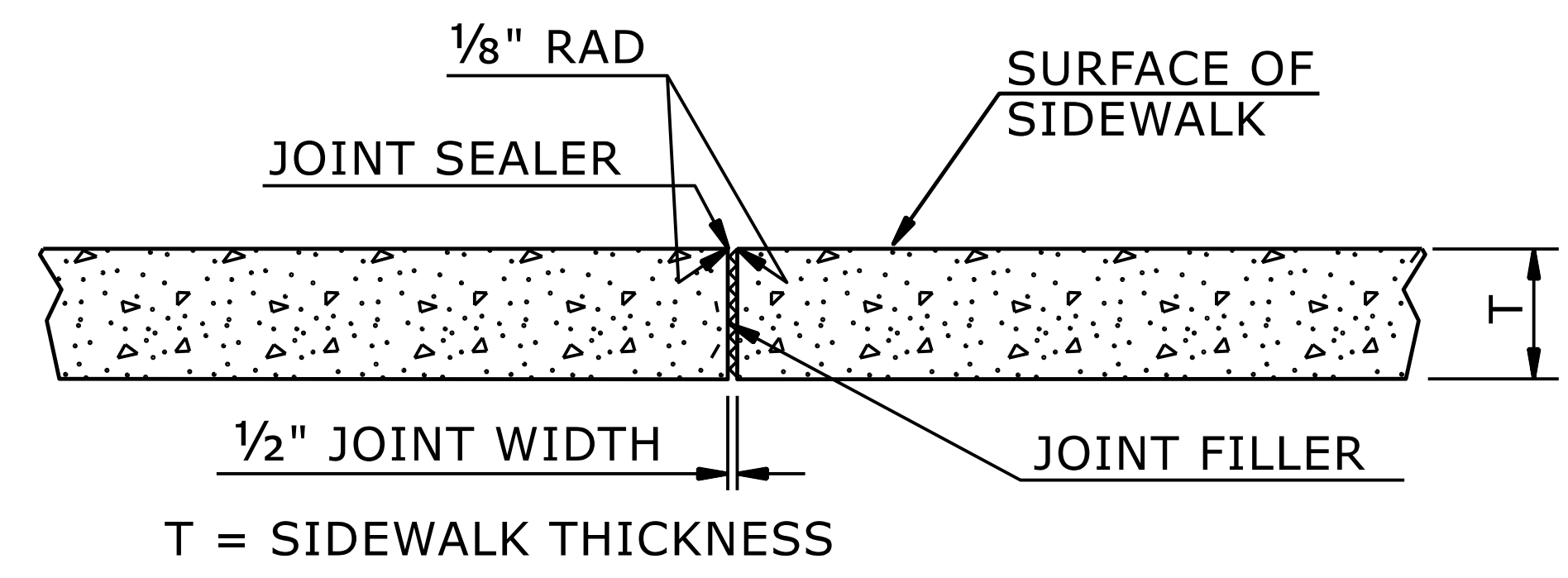

TRANSVERSE EXPANSION JOINT IN SIDEWALK

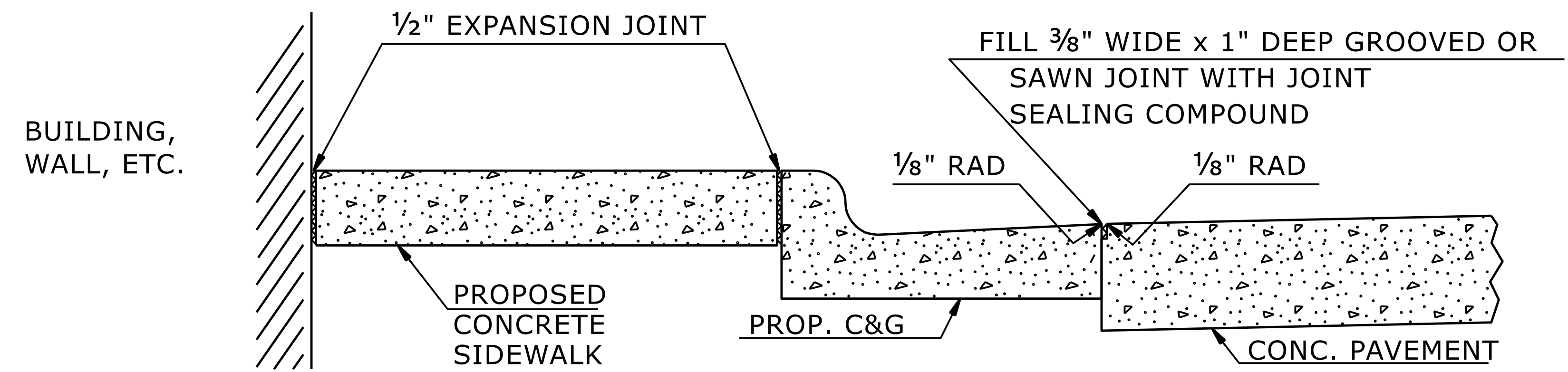

DETAILS SHOWING JOINTS IN CONCRETE SIDEWALK

STATE OF NORTH CAROLINA
DEPT. OF TRANSPORTATION
DIVISION OF HIGHWAYS
RALEIGH, N.C.

ROADWAY DETAIL DRAWING FOR
CONCRETE SIDEWALK



SHEET 1 OF 1
848D01

DOCUMENT NOT CONSIDERED FINAL
UNLESS ALL SIGNATURES COMPLETED

CONTRACTS STANDARDS AND DEVELOPMENT UNIT
Office 919-707-6950 FAX 919-250-4119

SEE TITLE BLOCK

ORIGINAL BY: S.CALHOUN	DATE: 7-25-2024
MODIFIED BY: _____	DATE: _____
CHECKED BY: _____	DATE: _____
FILE SPEC.: _____	

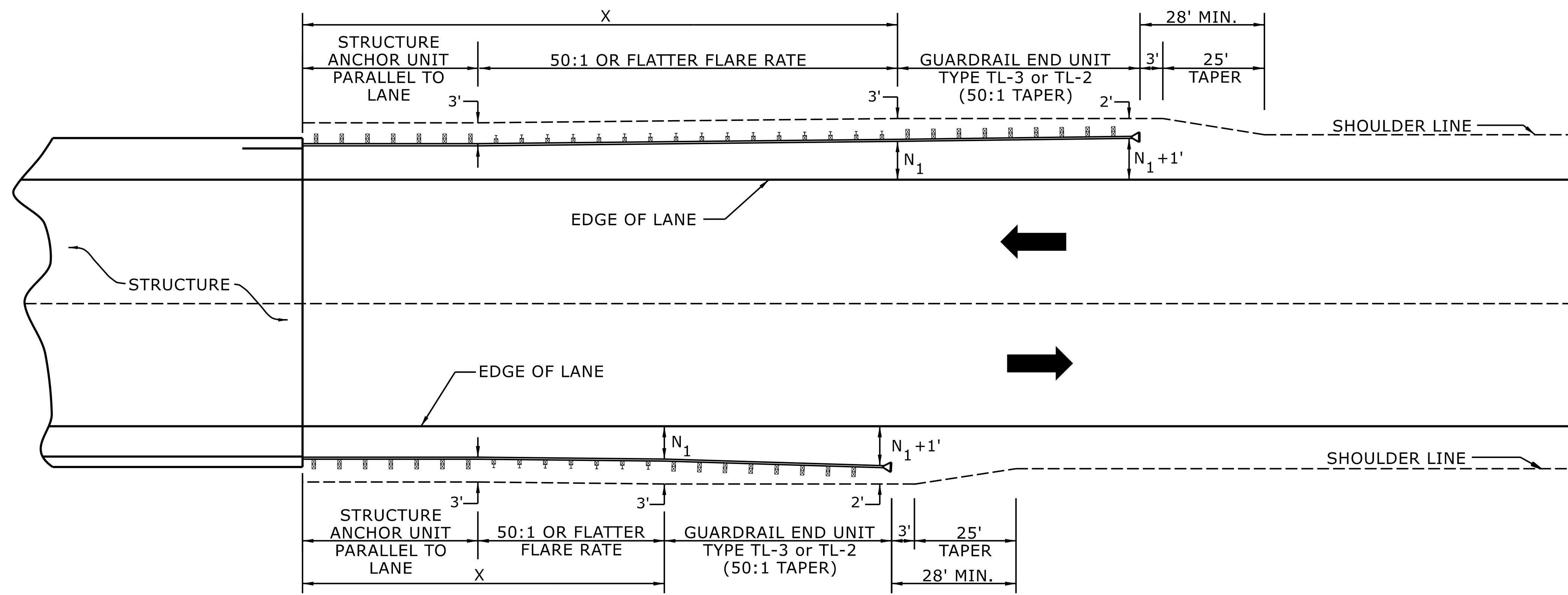

USE FLARE RATE AS THE CONTROL IF THE "N₁" DISTANCE IS NOT OBTAINED.
 ("N₁" IS BASED ON SHOULDER WIDTHS IN THE ROADWAY DESIGN MANUAL)
 SEE STD. 862.03 FOR STRUCTURE ANCHOR UNITS
 FOR POSTED SPEEDS ≥ 45MPH USE GREU TYPE TL-3
 FOR POSTED SPEEDS < 45MPH USE GREU TYPE TL-2
 GUARDRAIL LENGTH OF NEED (X) IS CALCULATED BASED ON THE AASHTO ROADSIDE DESIGN GUIDE.

LENGTHS AND OFFSETS FOR PROPOSED GUARDRAIL AT TWO LANE - TWO WAY LOCATIONS

STATE OF
 NORTH CAROLINA
 DEPT. OF TRANSPORTATION
 DIVISION OF HIGHWAYS
 RALEIGH, N.C.

ROADWAY DETAIL DRAWING FOR
GUARDRAIL PLACEMENT



SHEET 4 OF 15
862D01

DOCUMENT NOT CONSIDERED FINAL
 UNLESS ALL SIGNATURES COMPLETED

**CONTRACTS STANDARDS
 AND DEVELOPMENT UNIT**
 Office 919-707-6950 FAX 919-250-4119

SEE TITLE BLOCK

ORIGINAL BY: S.CALHOUN DATE: 7-25-2024
 MODIFIED BY: _____ DATE: _____
 CHECKED BY: _____ DATE: _____
 FILE SPEC.: _____

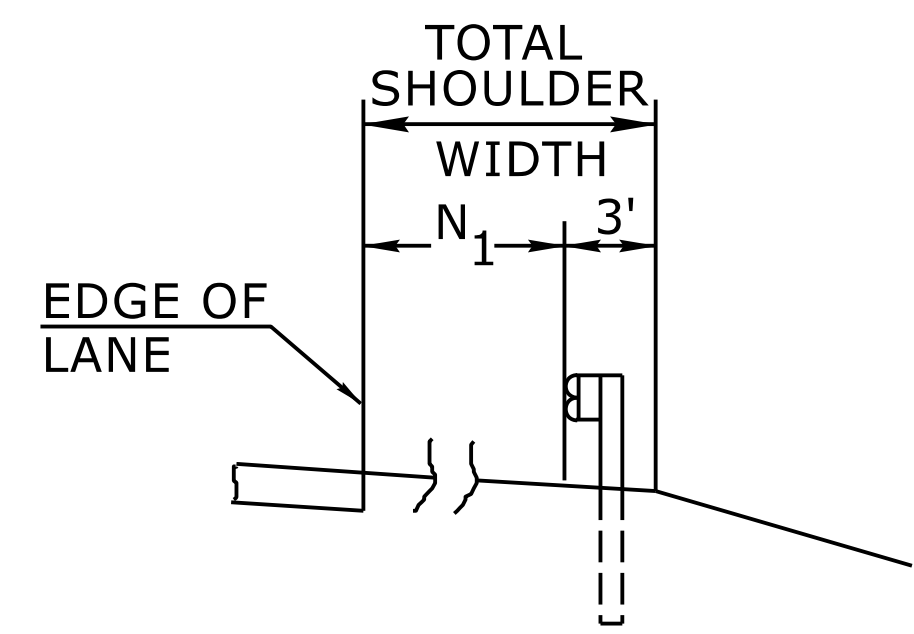

FILL SECTION

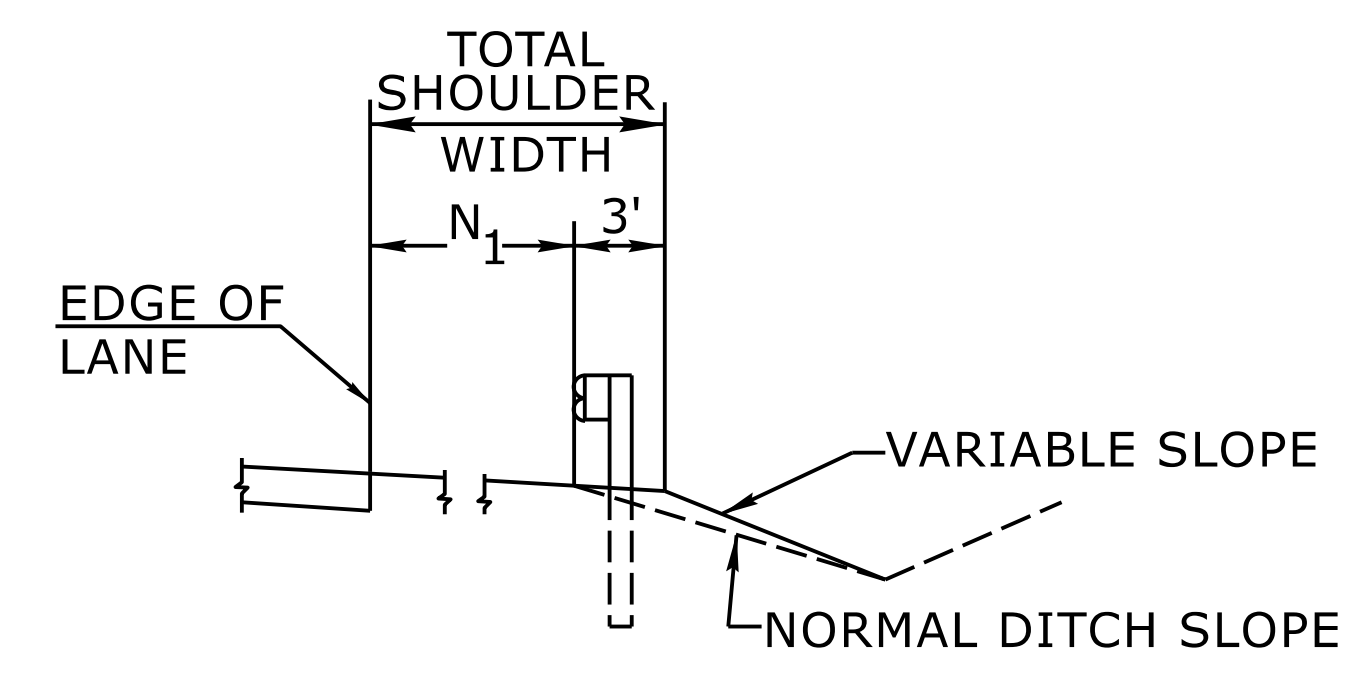

CUT SECTION

"N₁" = DISTANCE FROM EDGE OF LANE TO FACE OF GUARDRAIL WHERE GUARDRAIL IS PARALLEL TO LANE.

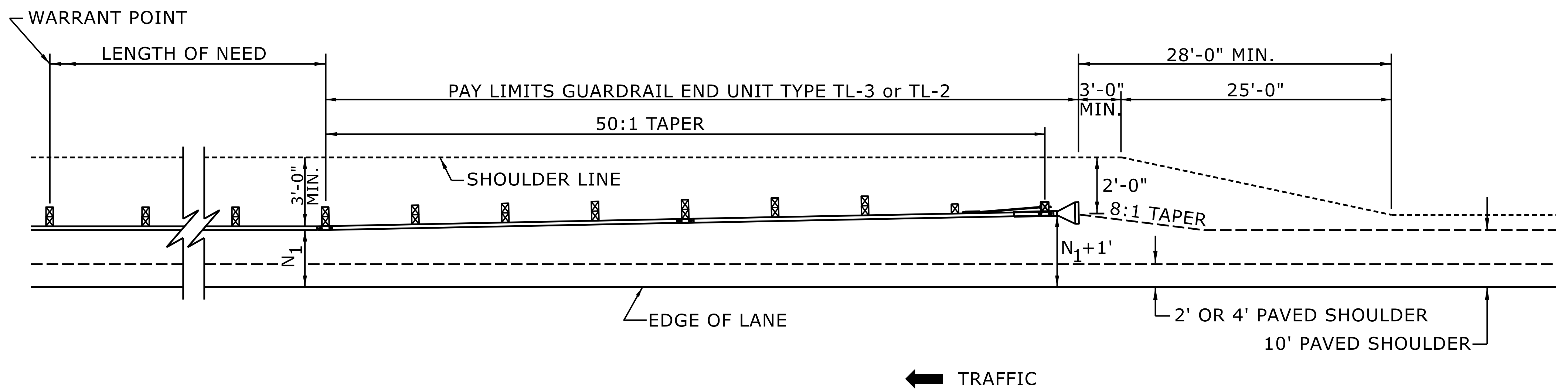

FOR POSTED SPEEDS ≥ 45mph USE GREU TYPE TL-3
FOR POSTED SPEEDS < 45mph USE GREU TYPE TL-2

DETAIL OF BEGINNING OF GUARDRAIL IN CUT OR FILL SECTION

STATE OF NORTH CAROLINA
DEPT. OF TRANSPORTATION
DIVISION OF HIGHWAYS
RALEIGH, N.C.

ROADWAY DETAIL DRAWING FOR
GUARDRAIL PLACEMENT



SHEET 6 OF 15
862D01

DOCUMENT NOT CONSIDERED FINAL
UNLESS ALL SIGNATURES COMPLETED

CONTRACTS STANDARDS AND DEVELOPMENT UNIT
Office 919-707-6950 FAX 919-250-4119

SEE TITLE BLOCK

ORIGINAL BY: S.CALHOUN	DATE: 7-25-2024
MODIFIED BY: _____	DATE: _____
CHECKED BY: _____	DATE: _____
FILE SPEC.: _____	

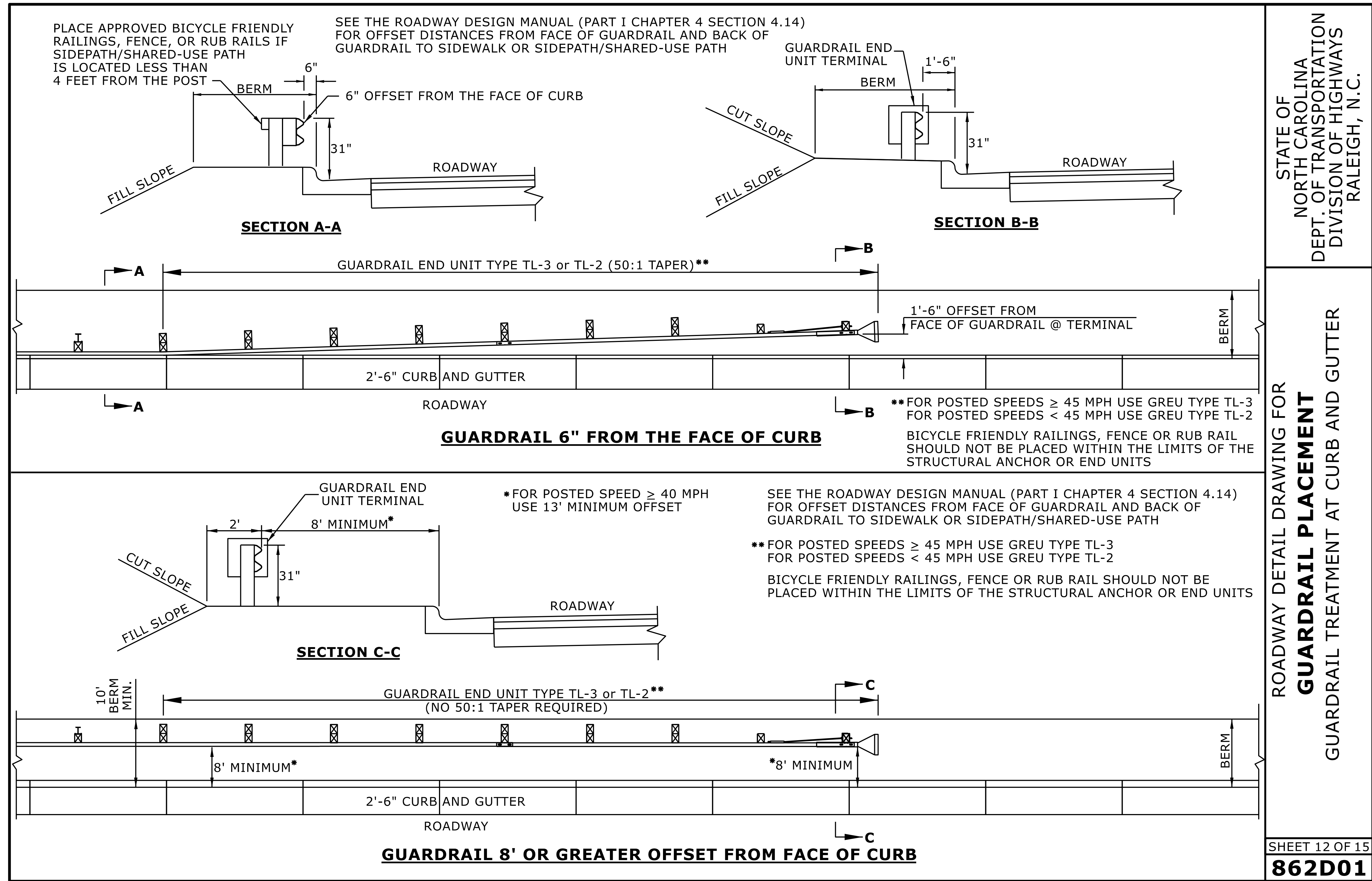

STATE OF NORTH CAROLINA
 DEPT. OF TRANSPORTATION
 DIVISION OF HIGHWAYS
 RALEIGH, N.C.

ROADWAY DETAIL DRAWING FOR
GUARDRAIL PLACEMENT
 GUARDRAIL TREATMENT AT CURB AND GUTTER



SHEET 12 OF 15
862D01

DOCUMENT NOT CONSIDERED FINAL
 UNLESS ALL SIGNATURES COMPLETED

CONTRACTS STANDARDS AND DEVELOPMENT UNIT
 Office 919-707-6950 FAX 919-250-4119

SEE TITLE BLOCK

ORIGINAL BY: S.CALHOUN DATE: 7-25-2024
 MODIFIED BY: _____ DATE: _____
 CHECKED BY: _____ DATE: _____
 FILE SPEC.: _____

(9-17-24)

**STATE OF NORTH CAROLINA
 DIVISION OF HIGHWAYS**

SUMMARY OF SUBSURFACE DRAINAGE

LINE	Station	Station	Location LT/RT/CL	Drain Type* UD/BD/SD	LF
				SD	200
				TOTAL LF:	200

*UD = Underdrain
 *BD = Blind Drain
 *SD = Subsurface Drain

SUMMARY OF ROCK PLATING

LINE	Beginning Slope (H:V)	Approx. Station	Ending Slope (H:V)	Approx. Station	Location LT/RT	Rock Plating Detail No. 1/2/3/4	Riprap Class* 1/2/B	Rock Plating SY
-L-	2.5:1	16+25	1.5:1	17+04	LT	1	*	170
-L-	1.5:1	20+78	2.5:1	21+75	LT	1	*	210
							TOTAL SY:	380

*Use Class 1, 2 or B riprap if riprap class is not shown for rock plating location.

PROJECT REFERENCE NO. B-5995	SHEET NO. 4
RW SHEET NO.	
ROADWAY DESIGN ENGINEER	HYDRAULICS ENGINEER
DOCUMENT NOT CONSIDERED FINAL UNLESS ALL SIGNATURES COMPLETED	

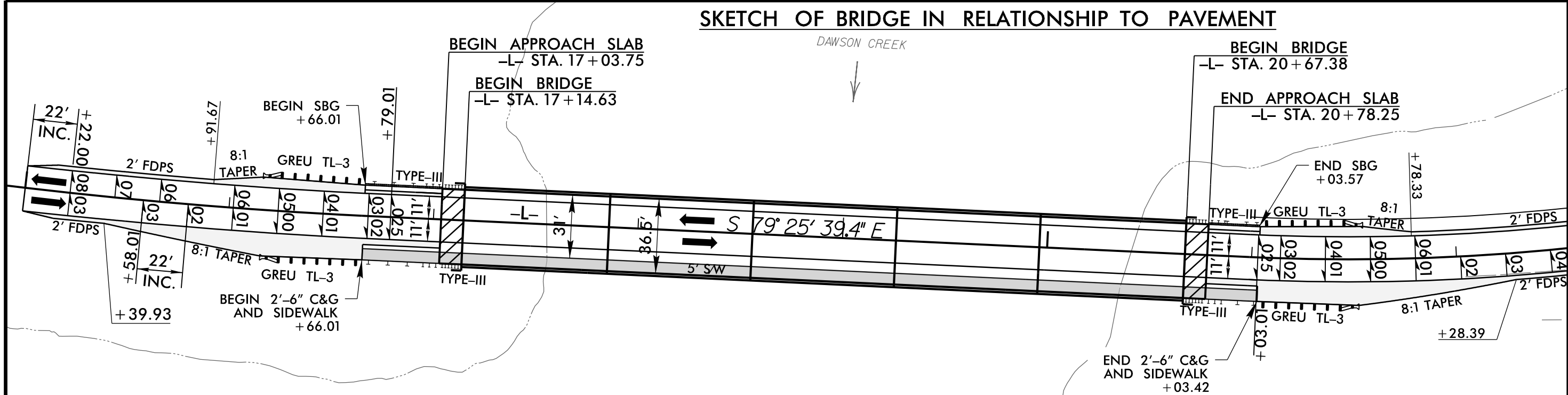
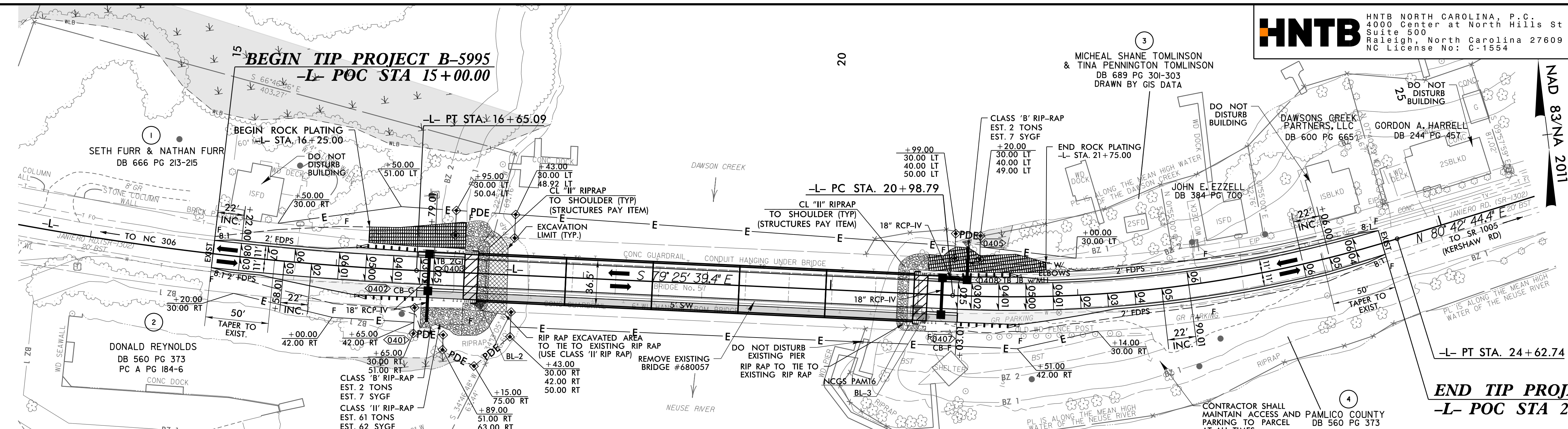

404 WETLANDS
 CAMA WETLANDS
 MATERIAL TO BE REMOVED
 NOTE: ALL RIP RAP SHALL BE GRANITE RIP RAP
 FOR STRUCTURE PLANS, SEE SHEETS S-1 THRU S-25

-L-
 PI Sta 14+20.11 PI Sta 22+82.61
 $\Delta = 11' 33" 42.1" (LT)$ $\Delta = 19' 51" 36.2" (LT)$
 $D = 2' 21" 06.1"$ $D = 5' 27" 24.3"$
 $L = 491.63'$ $L = 363.95'$
 $T = 246.65'$ $T = 183.82'$
 $R = 2,436.36'$ $R = 1,050.00'$
 $SE = EXIST$ $SE = 0.06$
 $RO = N/A$ $RO = 132'$

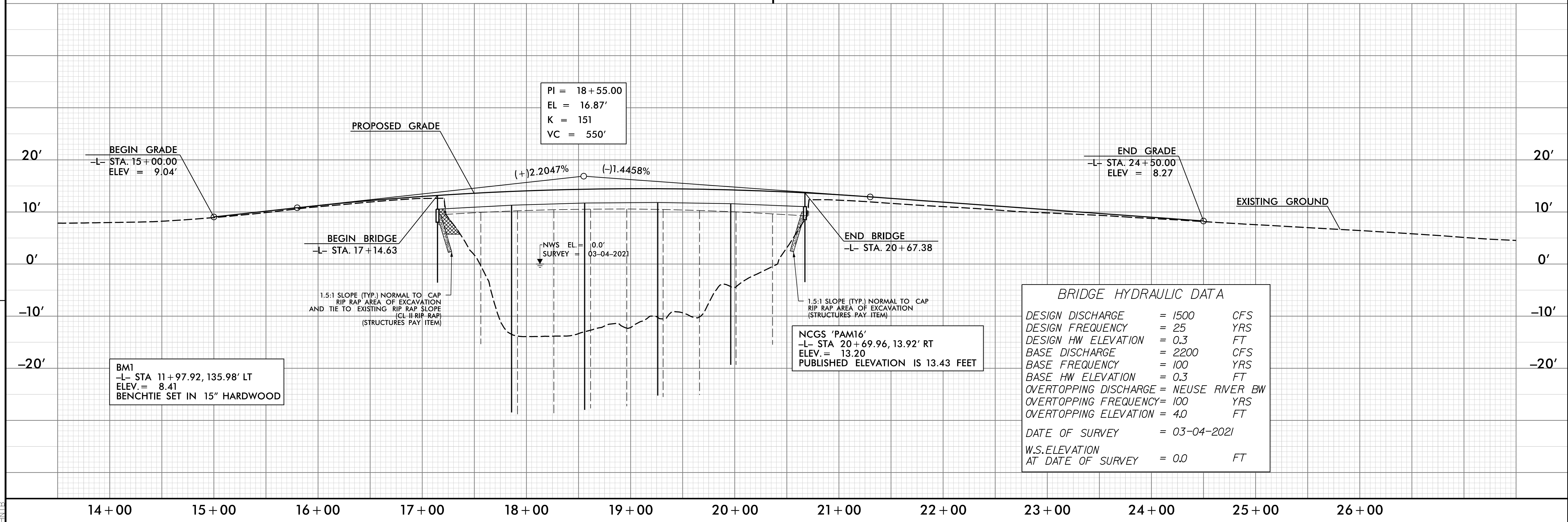

REVISIONS

16-FEB-2026 16:22 B5995_RDY_PSH4.dgn
 16-FEB-2026 16:22 B5995_RDY_PSH4.dgn