

HE-0016
RDY 6

NORTH CAROLINA
DEPARTMENT OF TRANSPORTATION
BRUNSWICK COUNTY

ROADWAY DESIGN UNIT
ROADWAY DESIGN ENGINEER

Professional Engineer Seal: WILLIAM L. GRAINGER, SEAL 045691, ENGINEER, EXPIRES 12/31/2026

Signed by: *William L. Grainger*
Professional Engineer

Professional Engineer Seal: FARRIEL NELSON, SEAL 053425, ENGINEER, EXPIRES 12/31/2026

Signed by: *Fariel Nelson*
Professional Engineer

Professional Engineer Seal: MATTHEW HANSEY, SEAL 053425, ENGINEER, EXPIRES 12/31/2026

Signed by: *Matthew Hansey*
Professional Engineer

WETHERILL ENGINEERING
WE Design your Tomorrow ...
1223 Jones Franklin Road
Raleigh, NC 27606
(919) 851-8077
NC License F-0377

DOCUMENT NOT CONSIDERED FINAL
UNLESS ALL SIGNATURES COMPLETED

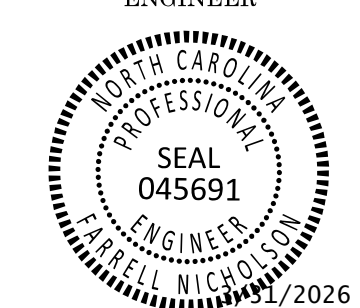
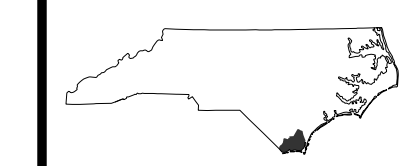

Signed by: Farrell Nelson, CIVIL ENGINEER



Signed by: Matthew Haney, CIVIL ENGINEER



WE Design your Tomorrow ... 1223 Jones Franklin Road, Raleigh, NC 27606, (919) 851-8077, NC License F-0377

DOCUMENT NOT CONSIDERED FINAL UNLESS ALL SIGNATURES COMPLETED

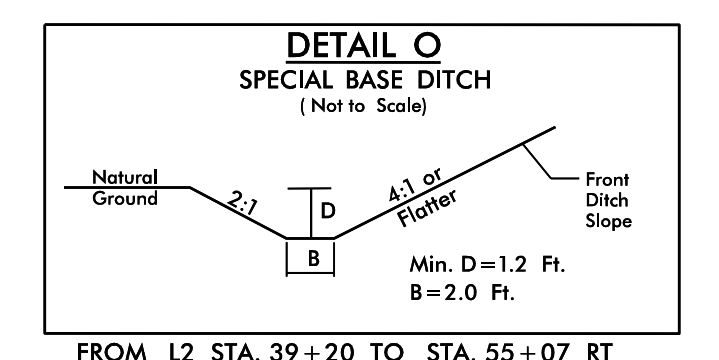
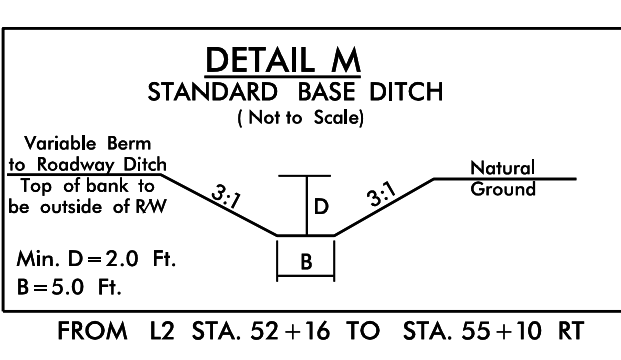
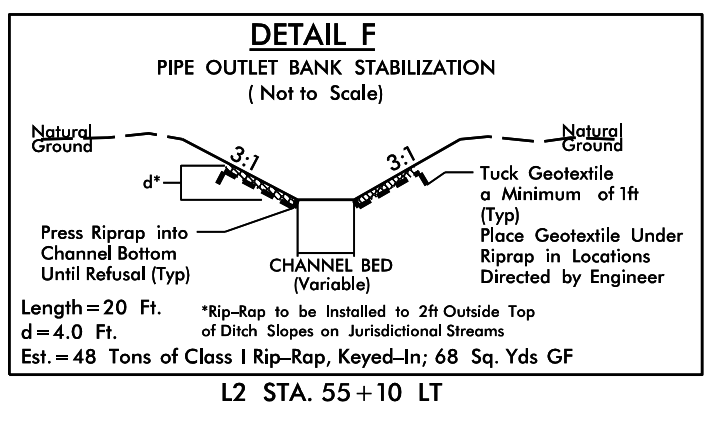
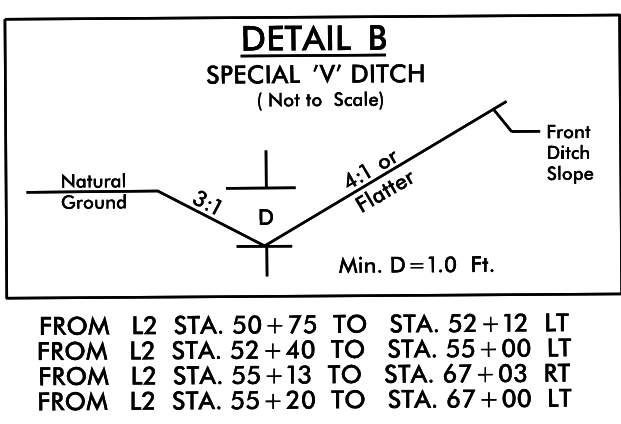
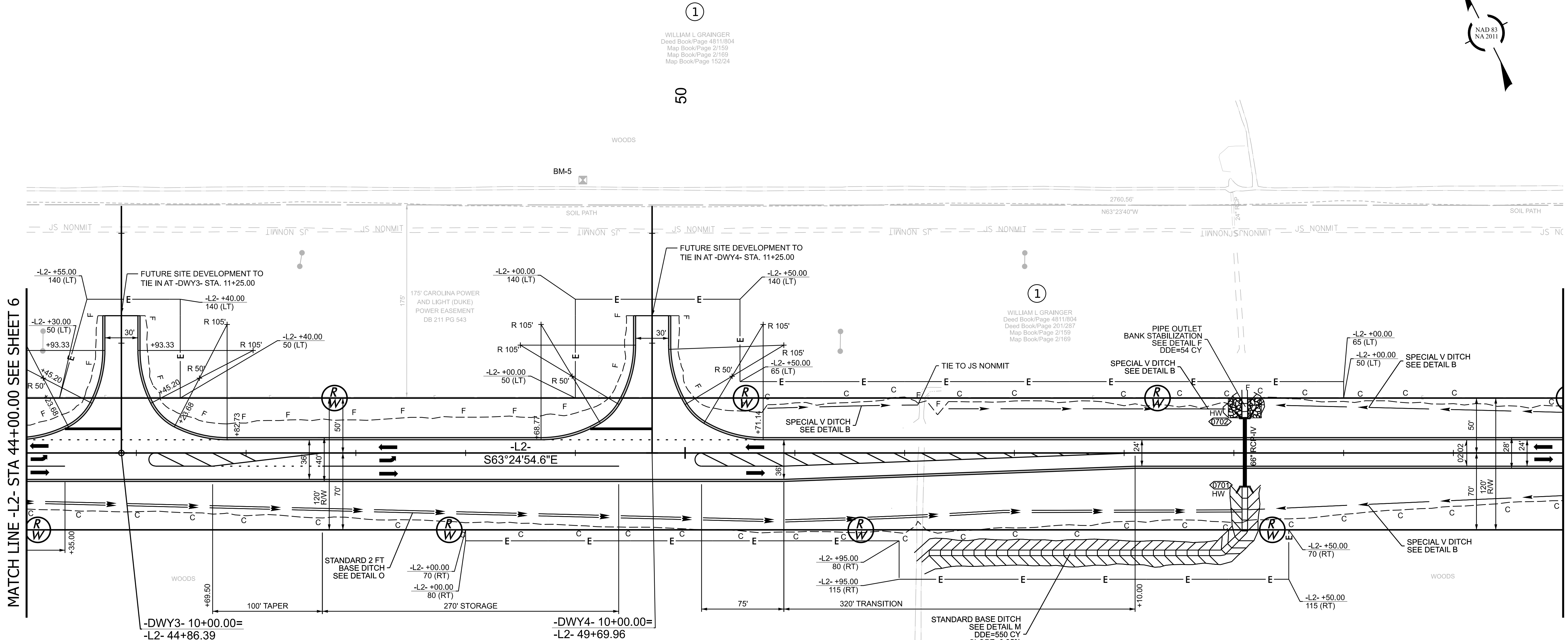

WILLIAM L GRAINGER, Deed Book/Page 4811804, Deed Book/Page 201/287, Map Book/Page 2/159, Map Book/Page 2/169

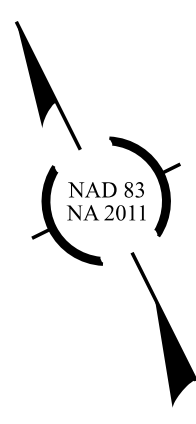

FOR -L2- PROFILE, SEE SHEET 13 THRU 14
FOR -DWY3- PROFILE, SEE SHEET 19
FOR -DWY4- PROFILE, SEE SHEET 19

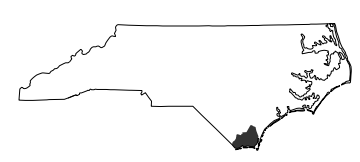

ROADWAY DESIGN UNIT
ROADWAY DESIGN
ENGINEER



Signed by:
William L. Grainger
CIVIL ENGINEER



Signed by:
Matthew L. Harvey
CIVIL ENGINEER

PREPARED BY
WETHERILL ENGINEERING

WE Design your Tomorrow ...

1223 Jones Franklin Road
Raleigh, NC 27606
(919) 851-8077

NC License F-0377

DOCUMENT NOT CONSIDERED FINAL
UNLESS ALL SIGNATURES COMPLETED

MATCH LINE -L2- STA 58+00.00 SEE SHEET 7

MATCH LINE -L2- STA 72+00.00 SEE SHEET 9

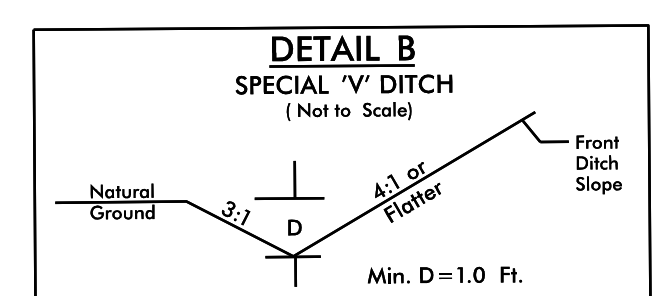
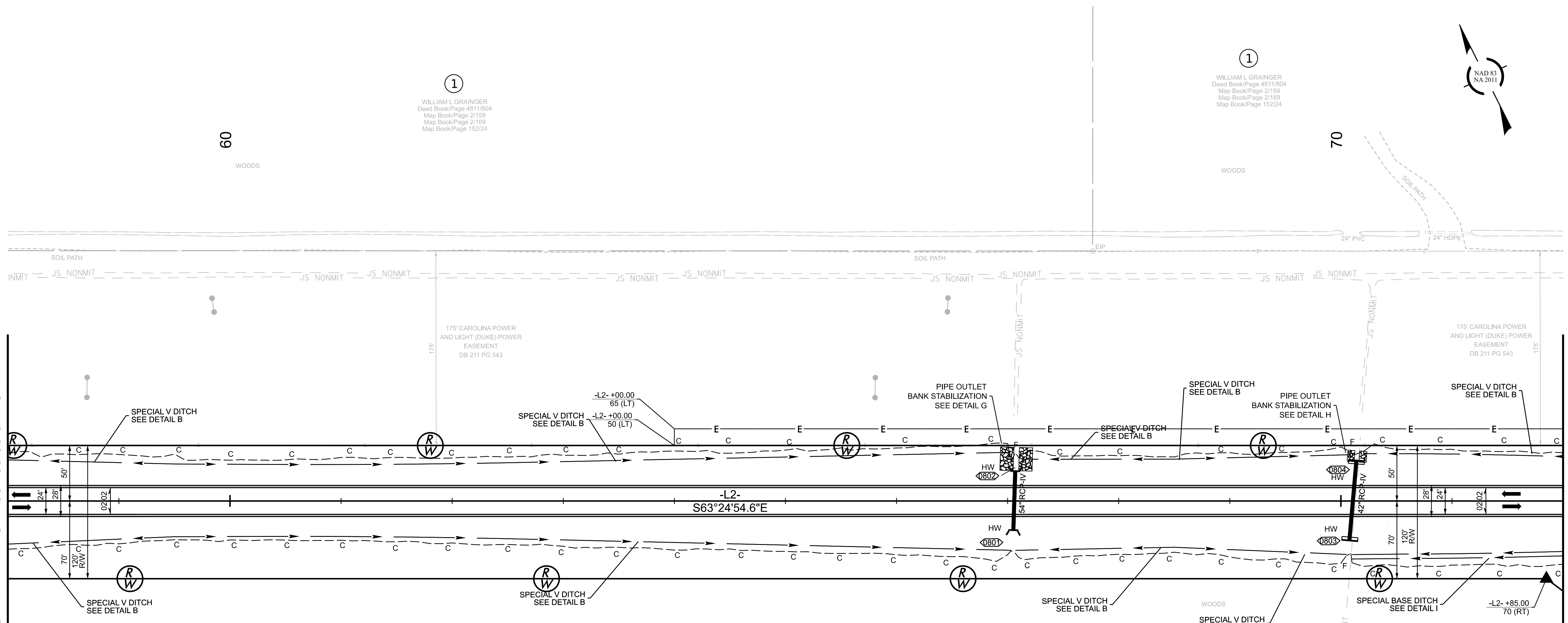

FROM L2 STA. 55+13 TO STA. 67+03 RT
FROM L2 STA. 52+20 TO STA. 67+00 LT
FROM L2 STA. 67+07 TO STA. 70+05 RT
FROM L2 STA. 67+15 TO STA. 70+08 LT
FROM L2 STA. 70+20 TO STA. 73+15 LT

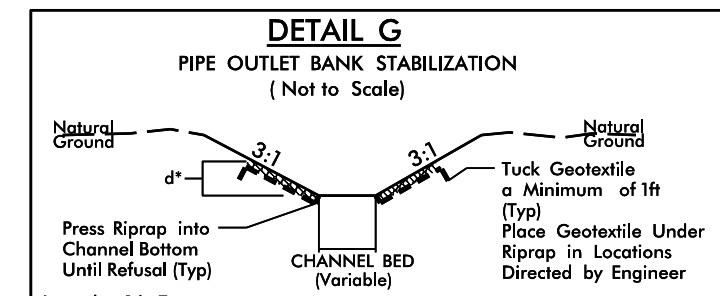

Length = 16 Ft. *Rip-Rap to be installed to 2ft Outside Top of Ditch Slopes on Jurisdictional Streams.
Est. = 40 Tons of Class I Rip-Rap, Keyed-In; 55 Sq. Yds GF
L STA. 67+06 LT

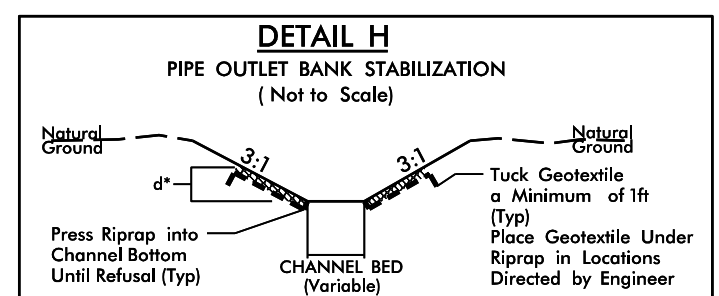

Length = 10 Ft. *Rip-Rap to be installed to 2ft Outside Top of Ditch Slopes on Jurisdictional Streams.
Est. = 7 Tons of Class B Rip-Rap, Keyed-In; 15 Sq. Yds GF
L2 STA. 70+15 LT

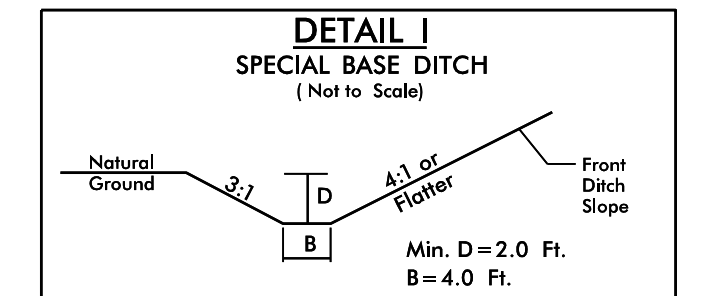

FROM L STA. 70+09 TO STA. 73+25 RT

1
WILLIAM L. GRAINGER
Deed Book/Page 4811/804
Map Book/Page 201/287
Map Book/Page 2/169
Map Book/Page 2/169



1
WILLIAM L. GRAINGER
Deed Book/Page 4811/804
Map Book/Page 2/169
Map Book/Page 2/169
Map Book/Page 152/24

1
WILLIAM L. GRAINGER
Deed Book/Page 4811/804
Map Book/Page 2/169
Map Book/Page 2/169
Map Book/Page 152/24

60
WOODS

70
WOODS

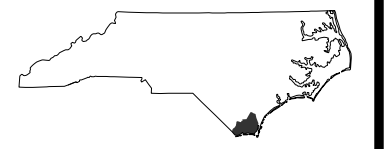

Signed by:
Farnell McDaniel
HYDRAULICS
ENGINEER



Signed by:
Matthew Harvey
HYDRAULICS
ENGINEER



WE Design your Tomorrow ...
1223 Jones Franklin Road
Raleigh, NC 27606
(919) 851-8077
NC License F-0377

DOCUMENT NOT CONSIDERED FINAL
UNLESS ALL SIGNATURES COMPLETED

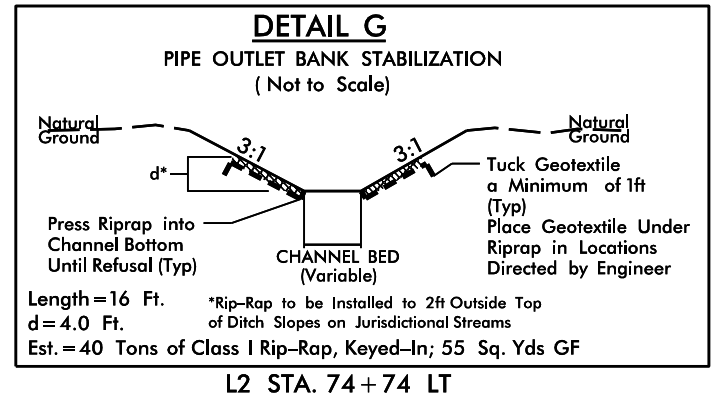
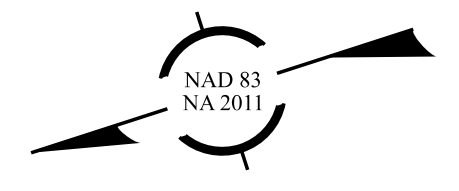

1
WILLIAM L GRAINGER
Deed Book/Page 4811/804
Deed Book/Page 201/287
Map Book/Page 2/169
Map Book/Page 2/169

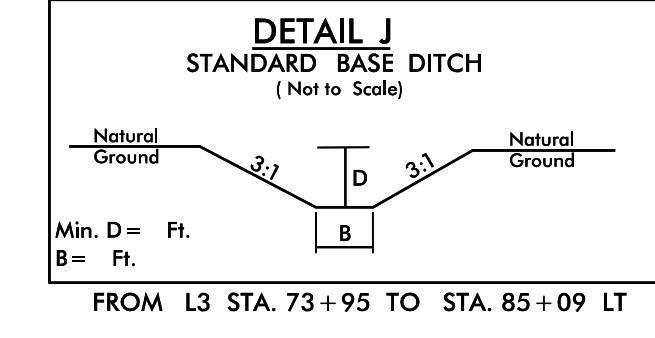
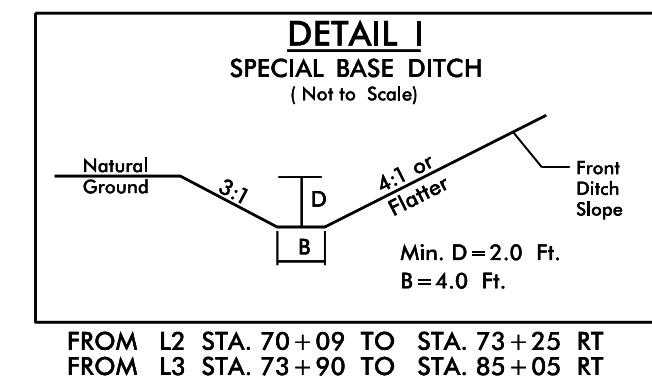
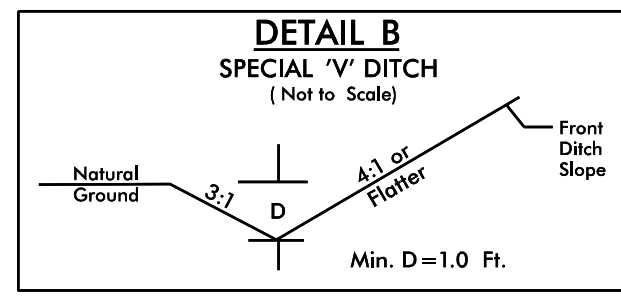

80

1
WILLIAM L GRAINGER
Deed Book/Page 4811/804
Deed Book/Page 201/287
Map Book/Page 2/169
Map Book/Page 152/24

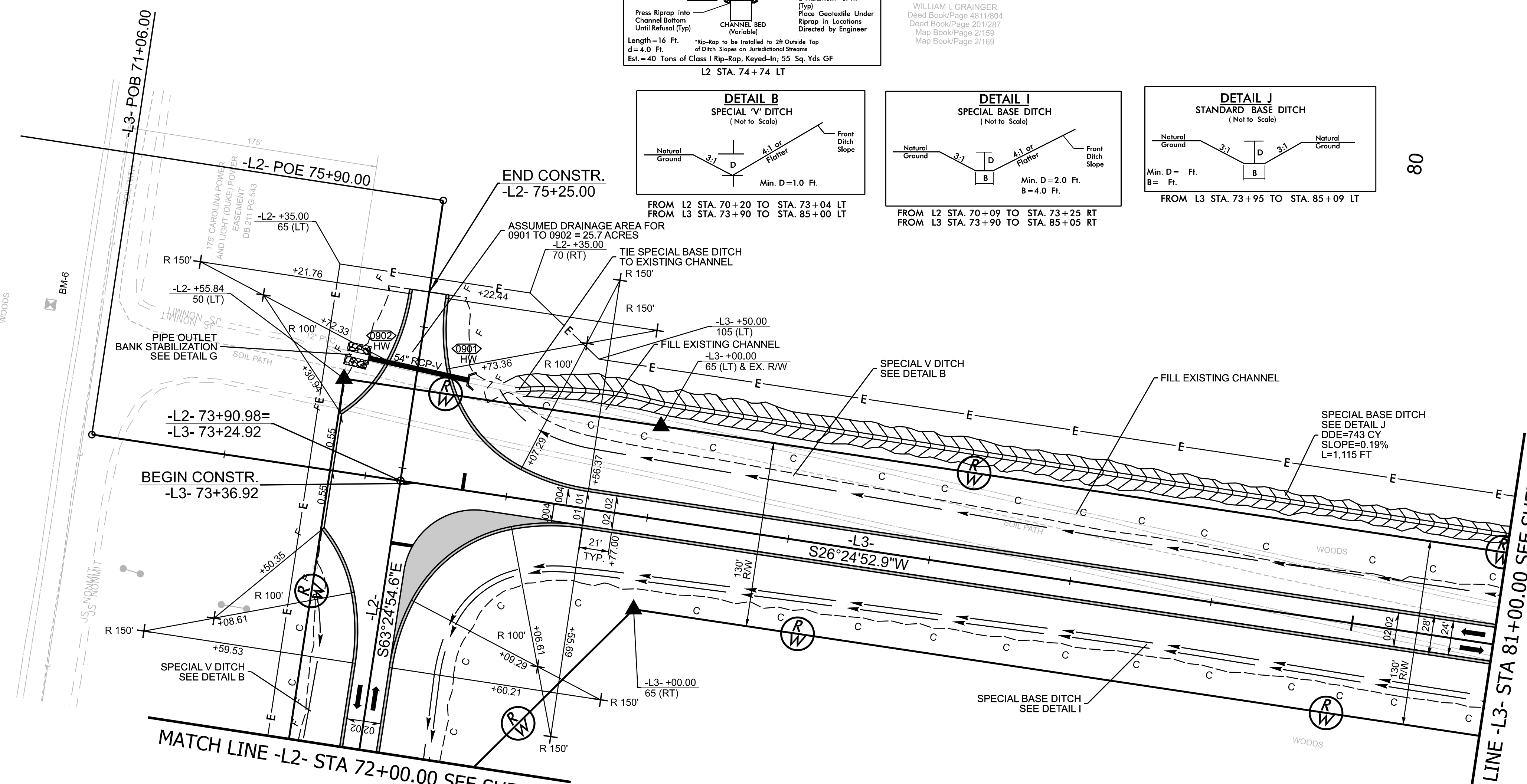

1
WILLIAM L GRAINGER
Deed Book/Page 4811/804
Deed Book/Page 201/287
Map Book/Page 2/169
Map Book/Page 2/169

MATCH LINE -L3- STA 81+00.00 SEE SHEET 9

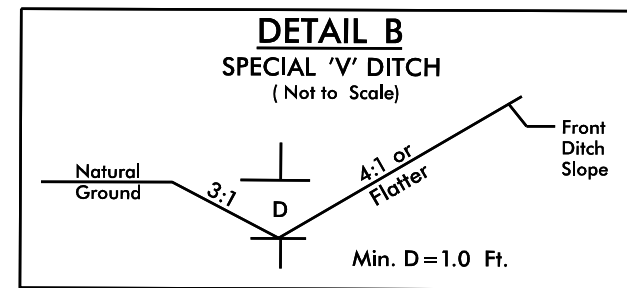

FROM L3 STA. 73+85 TO STA. 85+00 LT

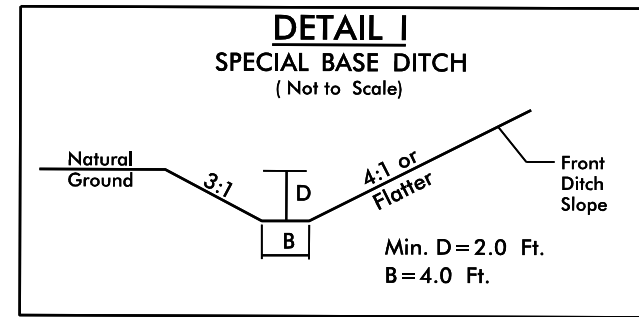

FROM L2 STA. 70+09 TO L3 STA. 85+05 RT

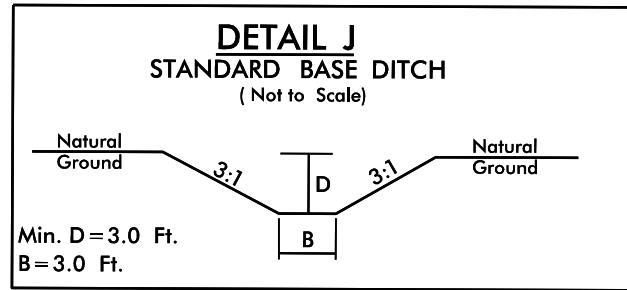

FROM L3 STA. 73+95 TO STA. 85+09 LT

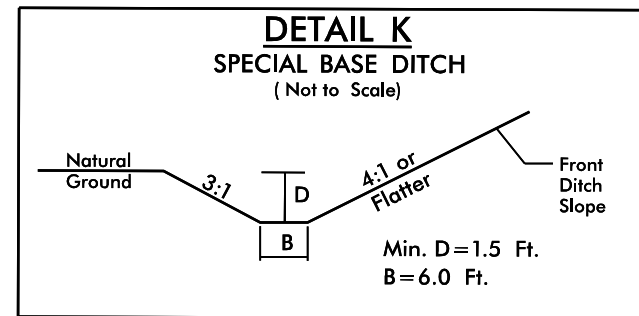

FROM Y1 STA. 74+00 TO STA. 74+90 LT
FROM Y1 STA. 76+30 TO STA. 82+00 LT

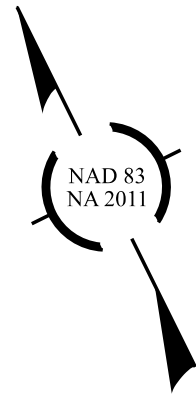
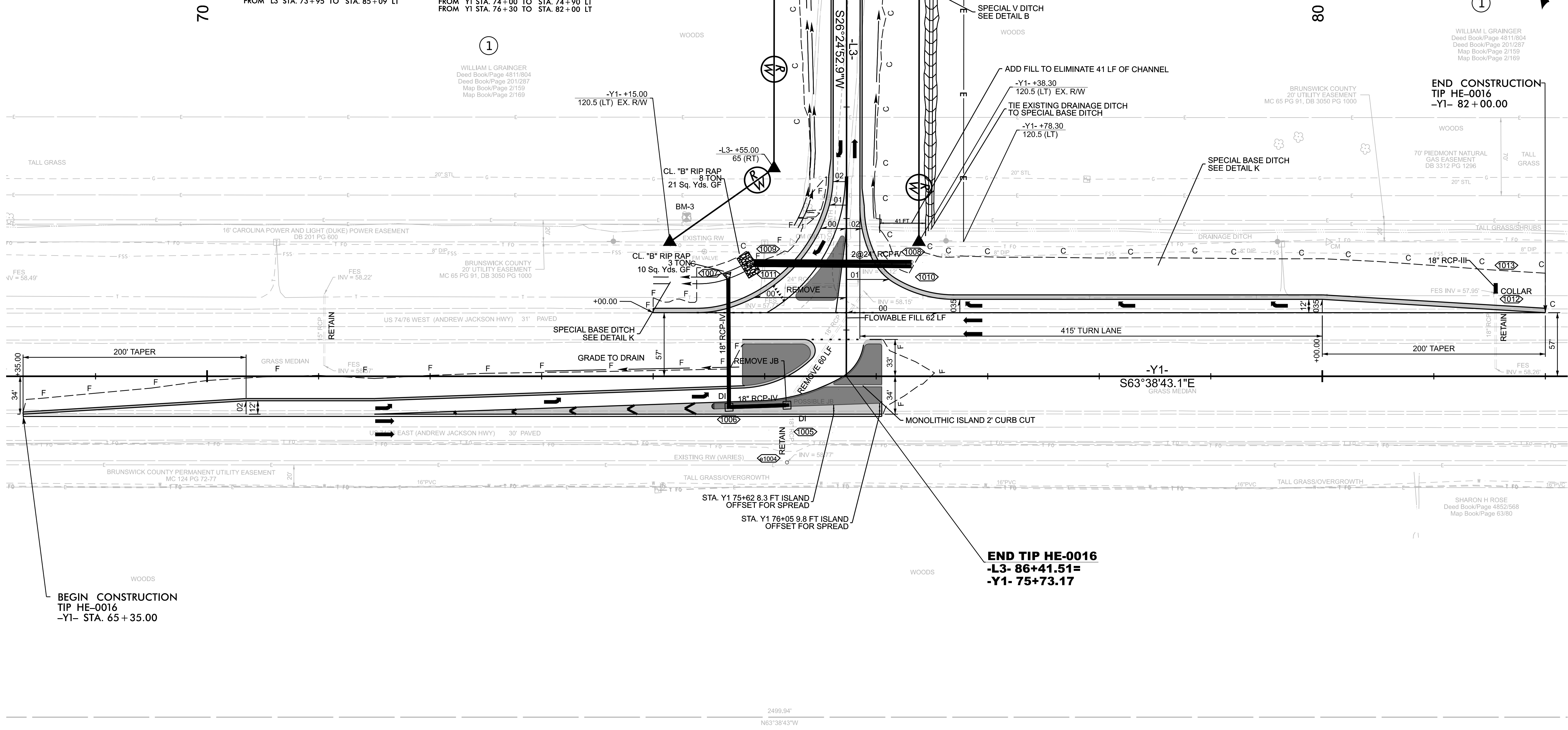

1
WILLIAM L GRAINGER
Deed Book/Page 4811/804
Deed Book/Page 201/287
Map Book/Page 21159
Map Book/Page 21169

WILLIAM L GRAINGER
Deed Book/Page 4811/804
Deed Book/Page 201/287
Map Book/Page 21159
Map Book/Page 21169

HE-0016
RDY 10

NORTH CAROLINA
DEPARTMENT OF TRANSPORTATION
BRUNSWICK COUNTY

ROADWAY DESIGN UNIT
ROADWAY DESIGN
ENGINEER

Seal: **SEAL 045691**
ENGINEER
MATTRELL NICHOLS
11/31/2026

Signed by: *Famill Nelson*
428ACME/PA/11/31/2026
ENGINEER

Seal: **SEAL 053425**
ENGINEER
WILLIAM L GRAINGER
11/31/2026

Signed by: *Matthew Haney*
DB419C/PA/11/31/2026
ENGINEER

WETHERILL ENGINEERING

WE Design your Tomorrow ...
1223 Jones Franklin Road
Raleigh, NC 27606
(919) 851-8077
NC License F-0377

DOCUMENT NOT CONSIDERED FINAL
UNLESS ALL SIGNATURES COMPLETED

SEE 2A-1 FOR MONOLITHIC CURB CUT DETAIL
SEE 2B-2 FOR INTERSECTION DETAILS
FOR -L3- PROFILE, SEE SHEET 15
FOR -Y1- PROFILE, SEE SHEET 16 & 18

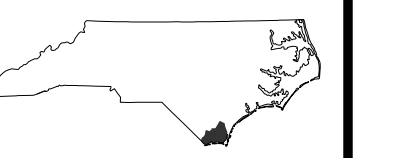

Signed by:
Farrell Nelson
CIVIL ENGINEER



Signed by:
Matthew Harney
CIVIL ENGINEER



WE Design your Tomorrow ...
1223 Jones Franklin Road
Raleigh, NC 27606
(919) 851-8077
NC License F-0377

DOCUMENT NOT CONSIDERED FINAL
UNLESS ALL SIGNATURES COMPLETED

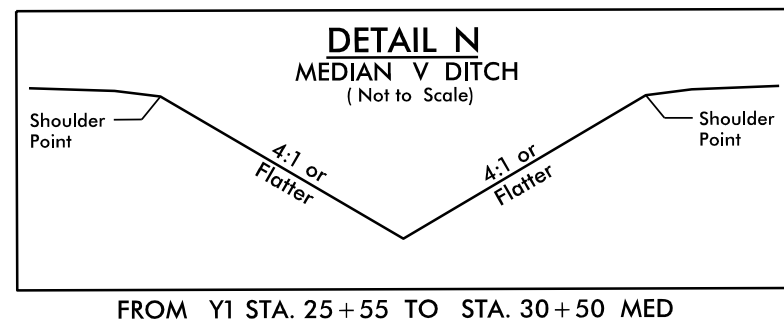
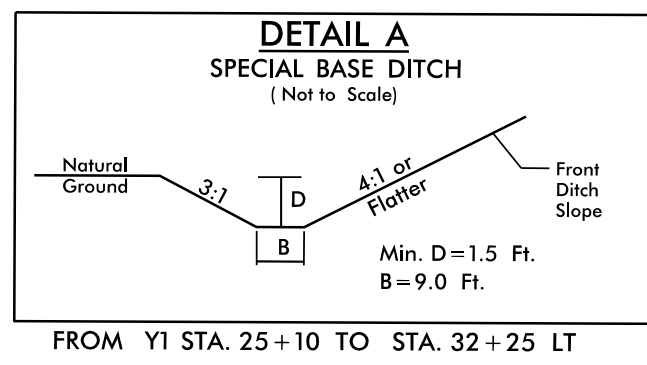

WILLIAM L GRAINGER
Deed Book/Page 4811/804
Deed Book/Page 201/287
Map Book/Page 2/159
Map Book/Page 2/169

WOODS

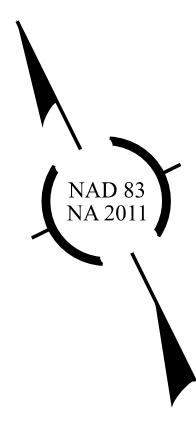

30

40

END CONSTRUCTION
TIP HE-0016
-Y1- STA. 32+65.00

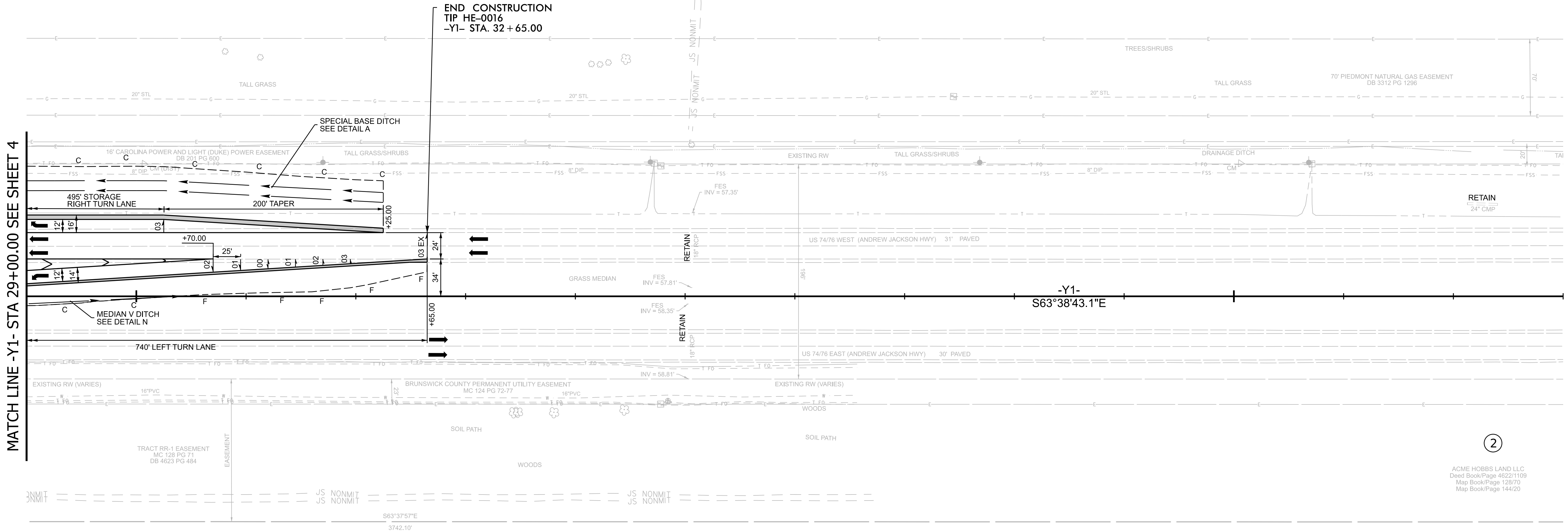

MATCH LINE -Y1- STA 29+00.00 SEE SHEET 4

2

ACME HOBBS LAND LLC
Deed Book/Page 4622/1109
Map Book/Page 128/70
Map Book/Page 144/20

S63°37'57\"/>

3742.10'

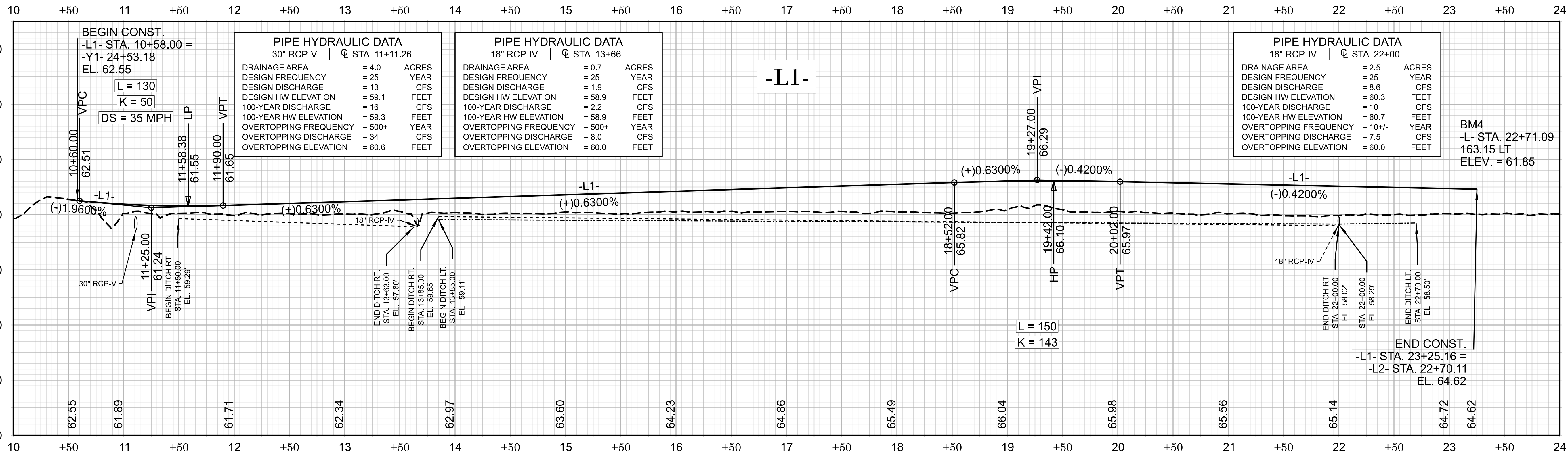

FOR -L1- PLAN, SEE SHEET 4 & 5

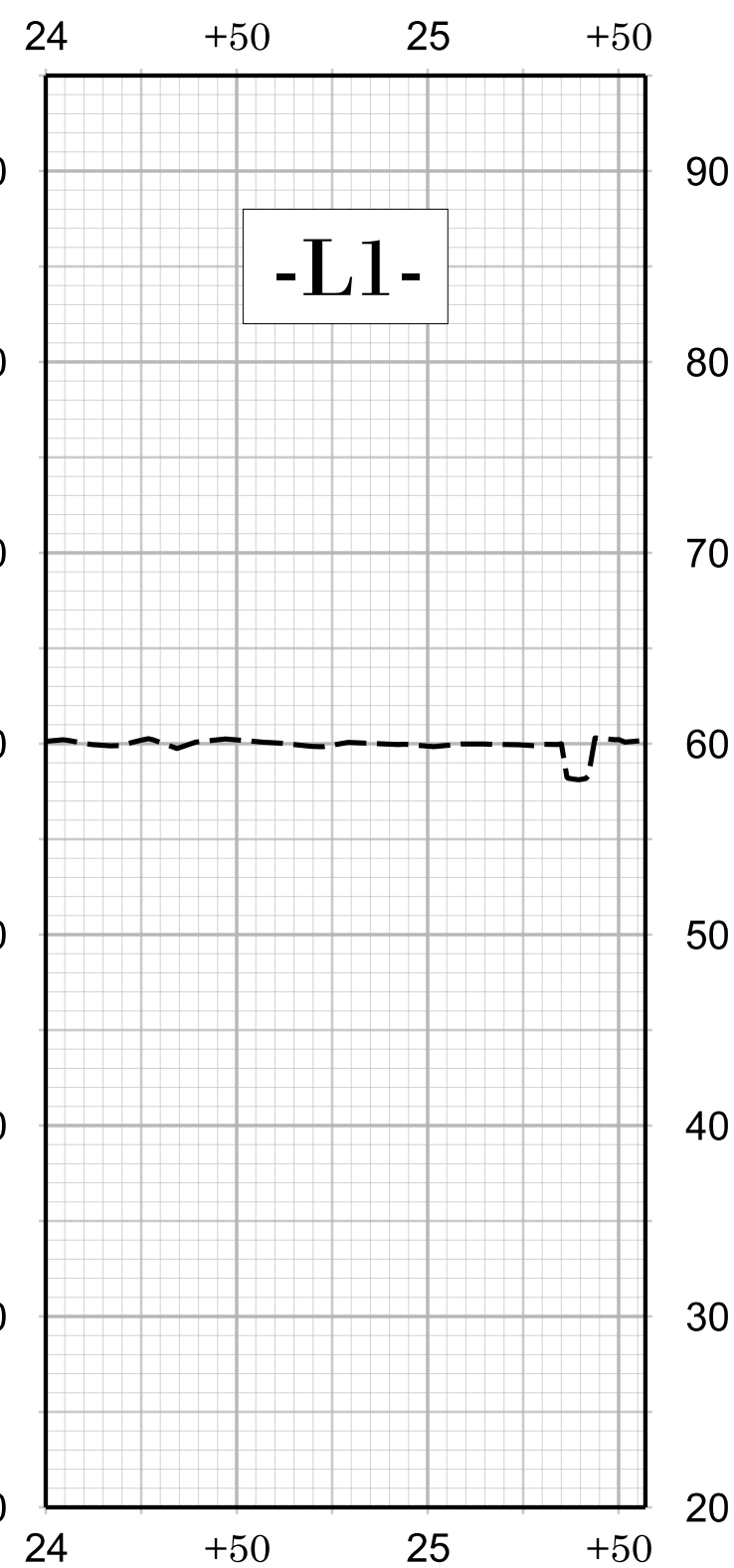

FOR -L1- PLAN, SEE SHEET 4 & 5

HE-0016

RDY 12

NORTH CAROLINA DEPARTMENT OF TRANSPORTATION BRUNSWICK COUNTY

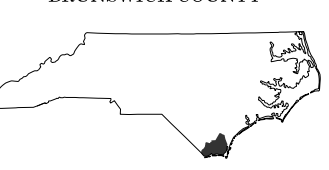

ROADWAY DESIGN UNIT

ROADWAY DESIGN ENGINEER



Signed by: Farnell Melson

HYDRAULICS ENGINEER



Signed by: Matthew Haney

PREPARED BY



WE Design your Tomorrow ...
1223 Jones Franklin Road
Raleigh, NC 27606
(919) 851-8077

NC License F-0377

DOCUMENT NOT CONSIDERED FINAL UNLESS ALL SIGNATURES COMPLETED

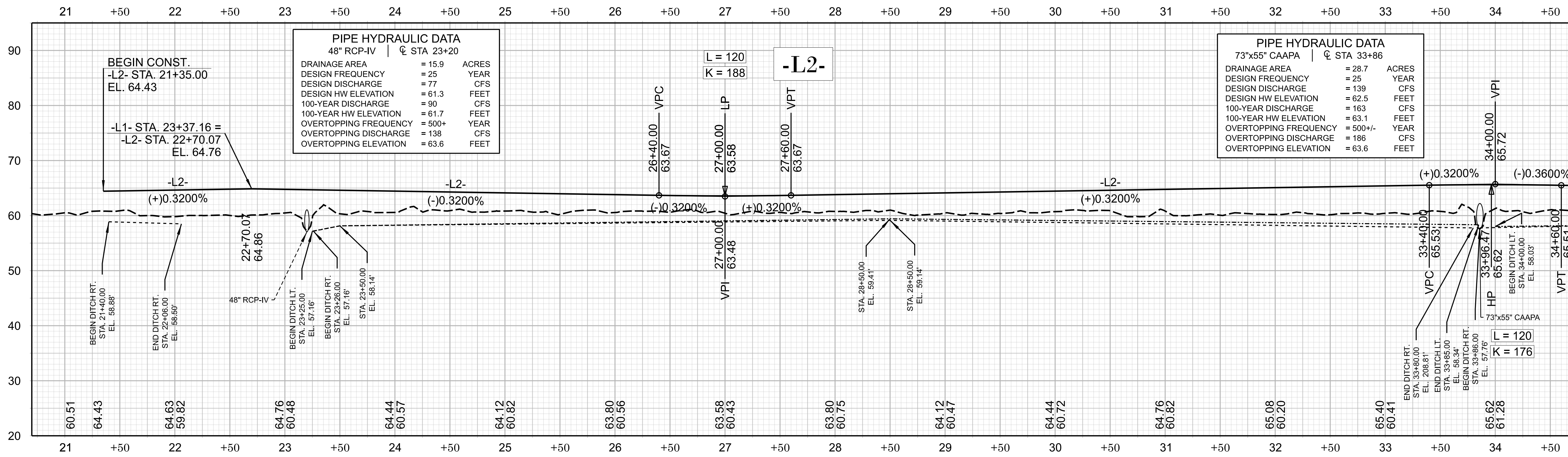

FOR -L2- PLAN, SEE SHEET 5 THRU 6

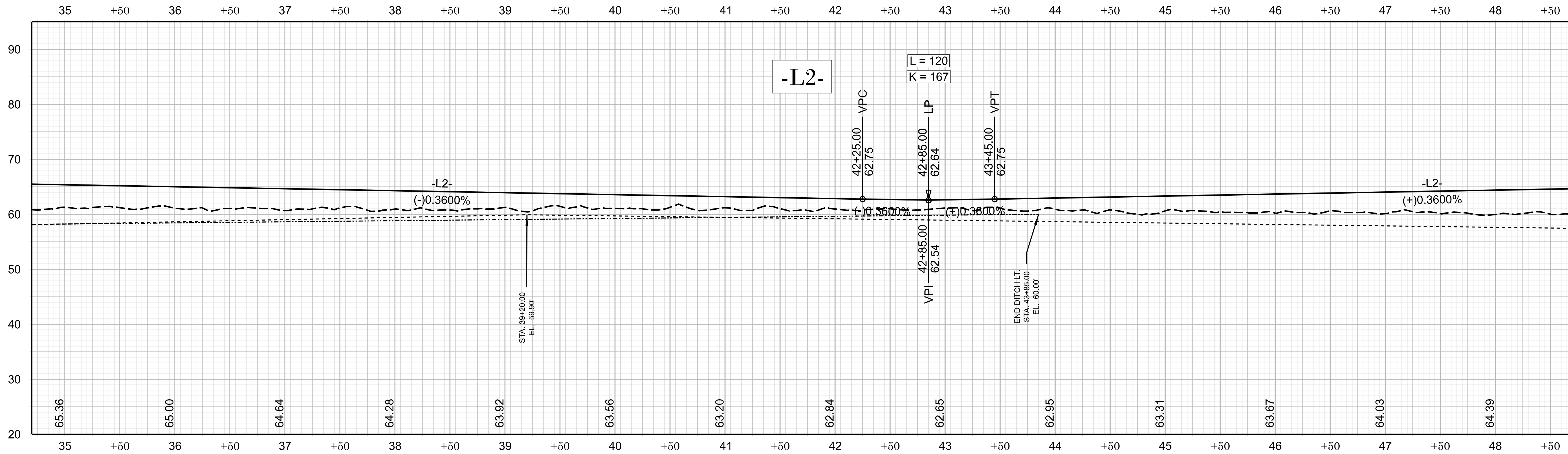

FOR -L2- PLAN, SEE SHEET 6 THRU 7

HE-0016
RDY 13
 NORTH CAROLINA
 DEPARTMENT OF TRANSPORTATION
 BRUNSWICK COUNTY

ROADWAY DESIGN UNIT
 ROADWAY DESIGN
 ENGINEER

SEAL
 045691
 ENGINEER
 MATTHEW L. HANCOCK
 11/2026

Signed by:
 Matthew Harney
 HYDRAULICS
 ENGINEER

SEAL
 053425
 ENGINEER
 MATTHEW L. HANCOCK
 11/2026

Signed by:
 Matthew Harney
 PREPARED BY

WETHERILL
ENGINEERING

WE Design your Tomorrow ...
 1223 Jones Franklin Road
 Raleigh, NC 27606
 (919) 851-8077
 NC License F-0377

DOCUMENT NOT CONSIDERED FINAL
 UNLESS ALL SIGNATURES COMPLETED

HE-0016
RDY 14

NORTH CAROLINA
 DEPARTMENT OF TRANSPORTATION
 BRUNSWICK COUNTY

ROADWAY DESIGN UNIT
 ROADWAY DESIGN
 ENGINEER

SEAL 045691
 ENGINEER
 LABEL NICHOLS
 11/2026

Signed by:
Farrill Nelson
 CIVIL ENGINEER

SEAL 053425
 ENGINEER
 MATTHEW L. HANNEY
 11/2026

Signed by:
Matthew Hanney
 CIVIL ENGINEER

WETHERILL ENGINEERING

WE Design your Tomorrow ...
 1223 Jones Franklin Road
 Raleigh, NC 27606
 (919) 851-8077

NC License F-0377

DOCUMENT NOT CONSIDERED FINAL
 UNLESS ALL SIGNATURES COMPLETED

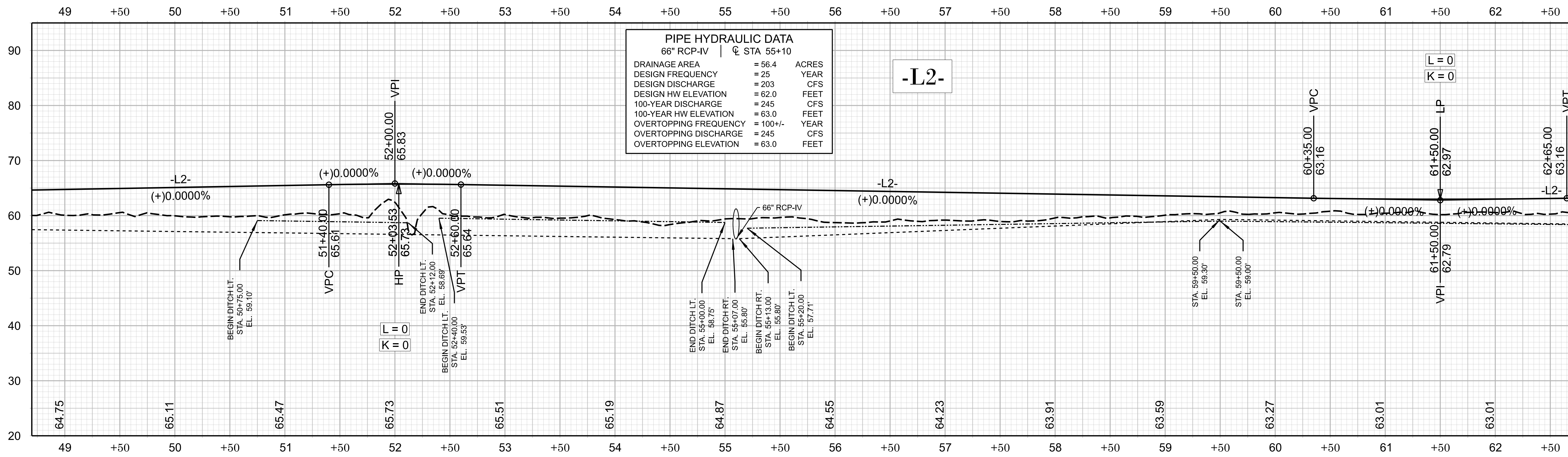

FOR -L2- PLAN, SEE SHEET 7 THRU 8

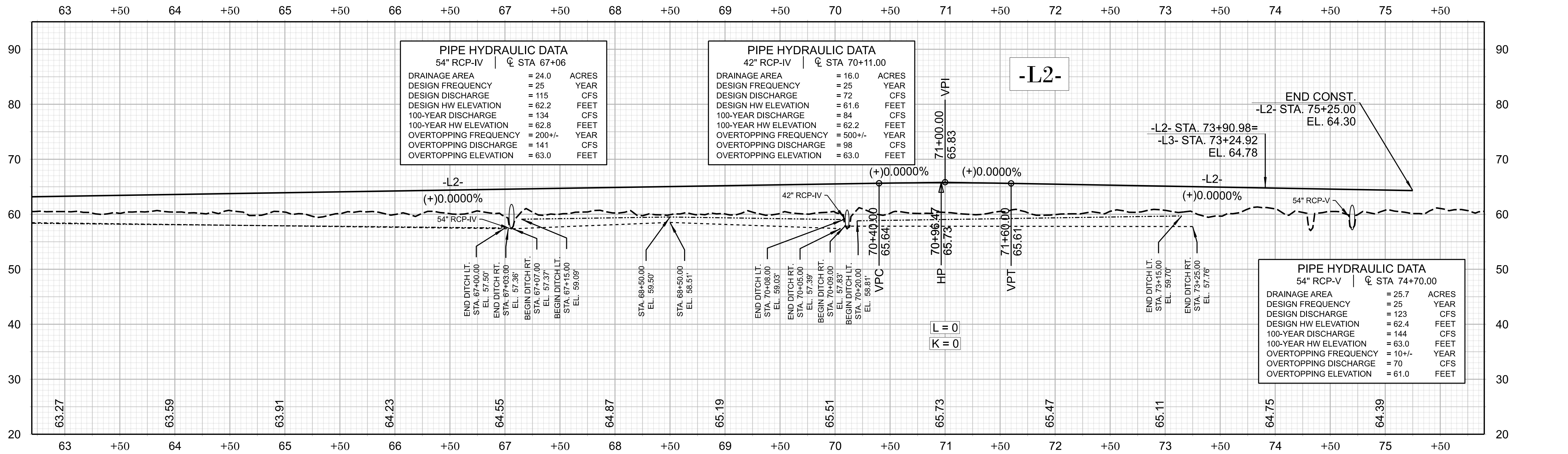

FOR -L2- PLAN, SEE SHEET 8 THRU 9

+50 72 +50 73 +50 74 +50 75 +50 76 +50 77 +50 78 +50 79 +50 80 +50 81 +50 82 +50 83 +50 84 +50 85

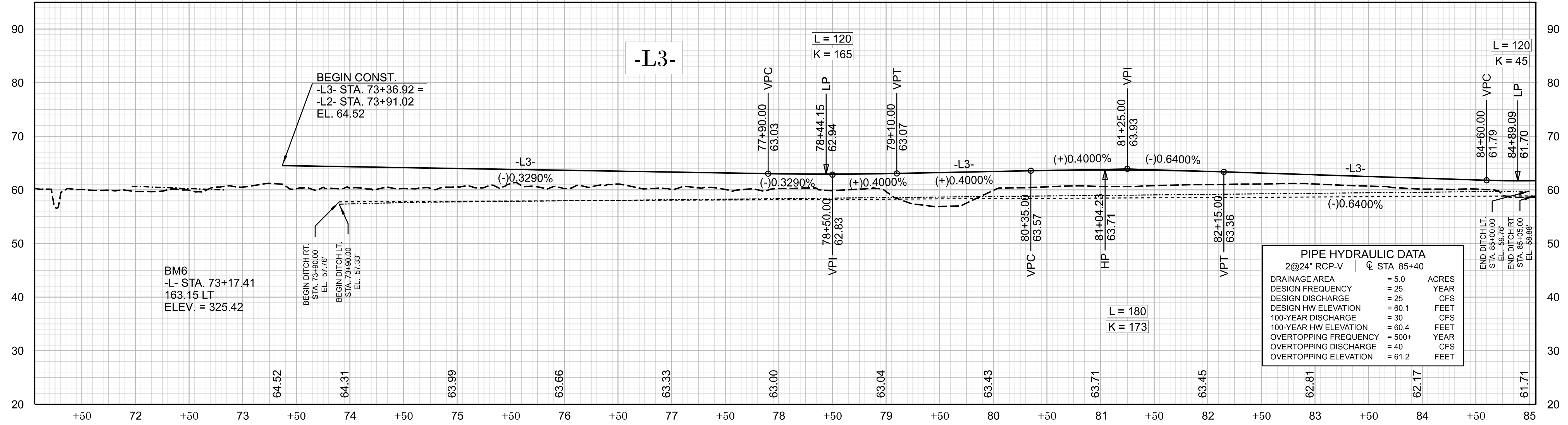

FOR -L3- PLAN, SEE SHEET 9 & 10

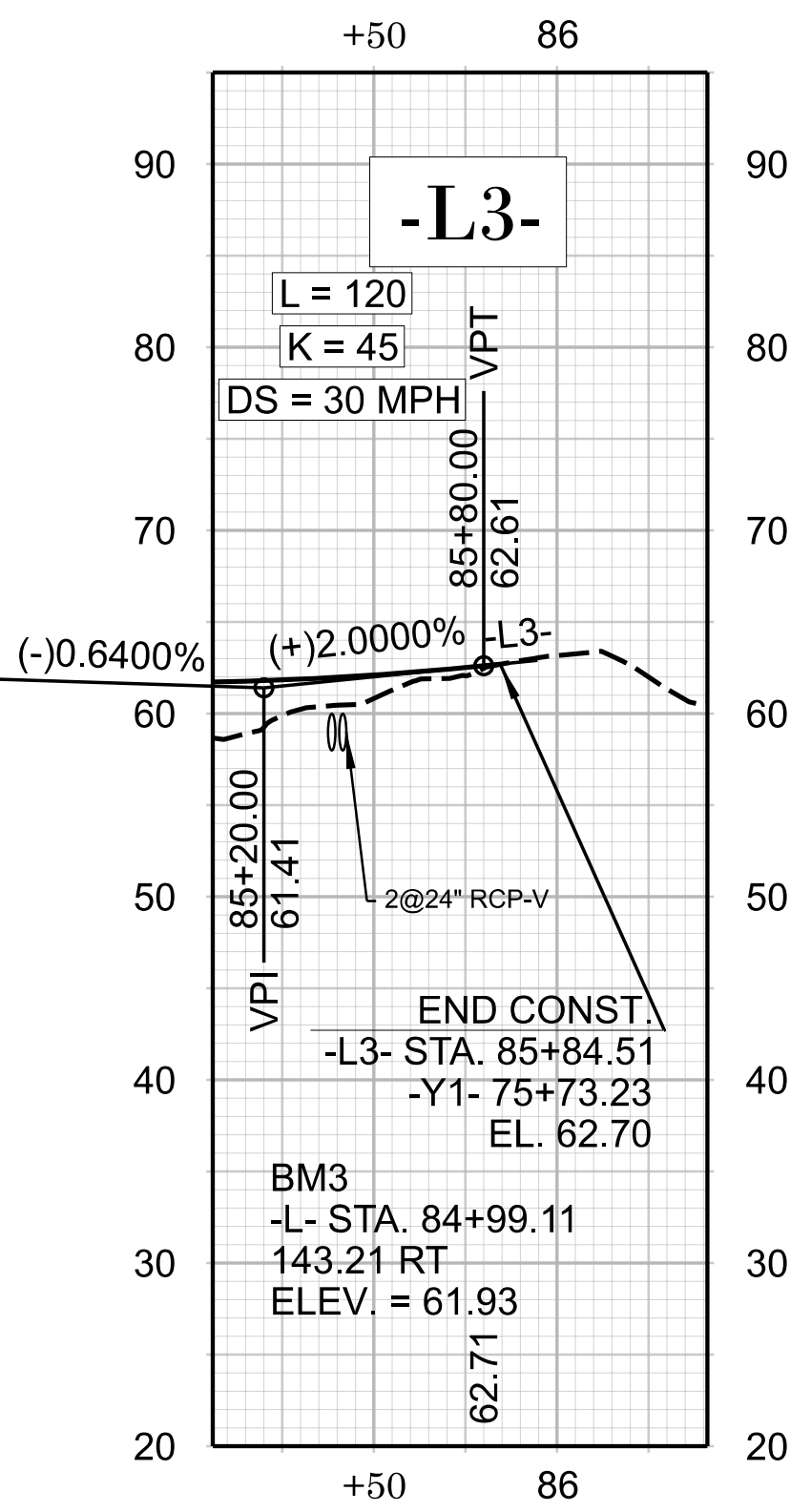

FOR -L3- PLAN, SEE SHEET 9 & 10

HE-0016
RDY 15

NORTH CAROLINA
DEPARTMENT OF TRANSPORTATION
BRUNSWICK COUNTY

ROADWAY DESIGN UNIT
ROADWAY DESIGN ENGINEER

Professional Engineer Seal: FARNELL NICHOLS, SEAL 045691, EXPIRES 12/2026

Signed by: Farnell Nichols, PE, HYDRAULICS ENGINEER

Professional Engineer Seal: MATTHEW L. HANBY, SEAL 053425, EXPIRES 12/2026

Signed by: Matthew Hanby, PE, HYDRAULICS ENGINEER

PREPARED BY: WETHERILL ENGINEERING

WE Design your Tomorrow ...
1223 Jones Franklin Road
Raleigh, NC 27606
(919) 851-8077
NC License F-0377

DOCUMENT NOT CONSIDERED FINAL UNLESS ALL SIGNATURES COMPLETED

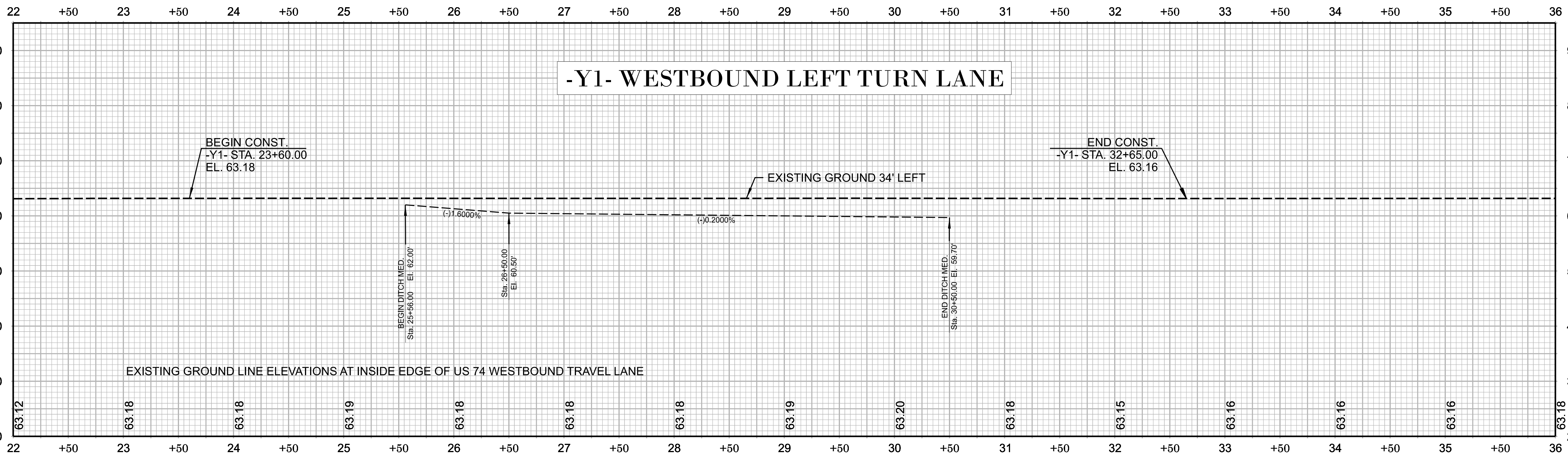

FOR -Y1- PLAN, SEE SHEET 4 & 11

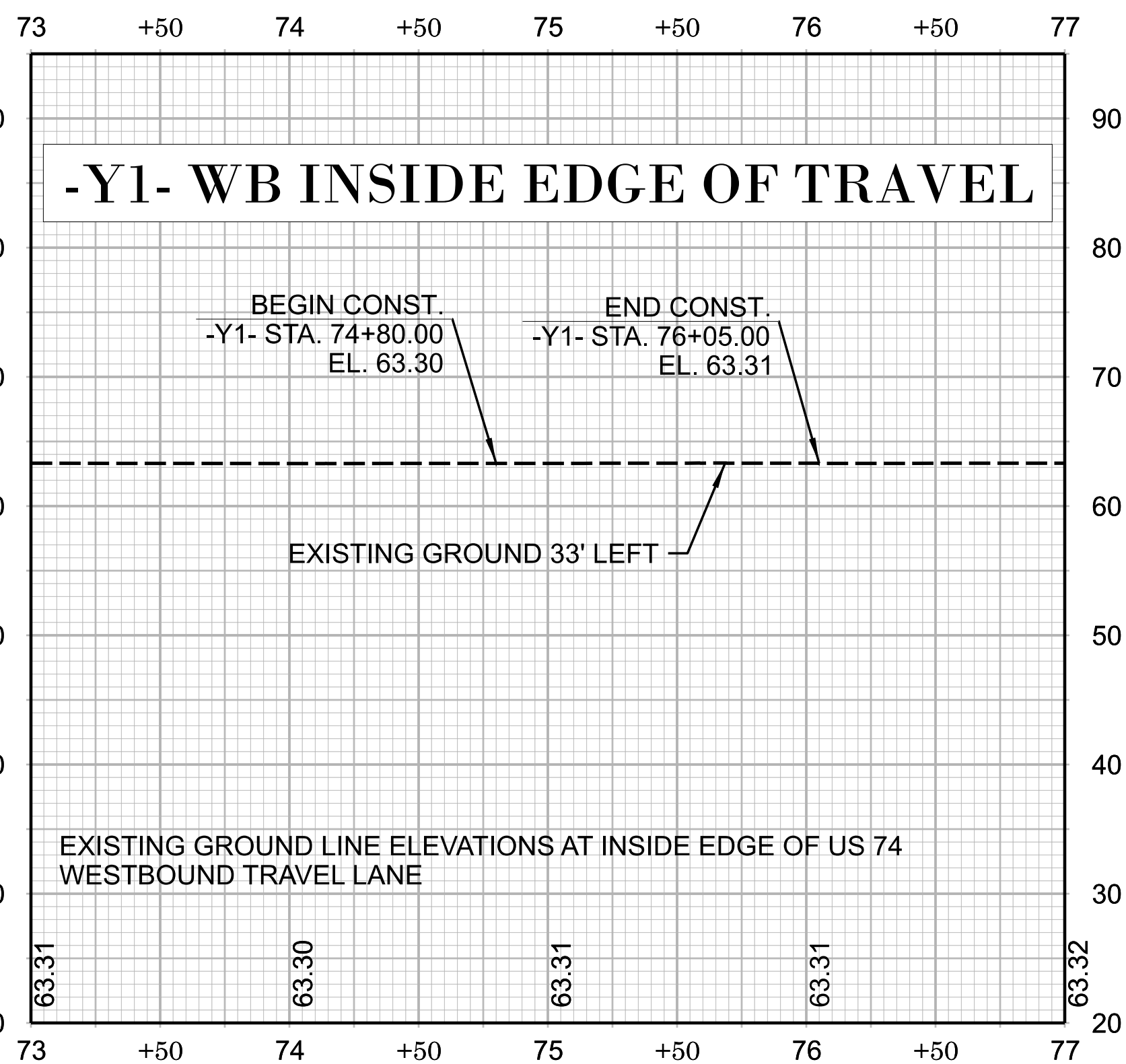

FOR -Y1- PLAN, SEE SHEET 10

HE-0016

RDY 17

NORTH CAROLINA
 DEPARTMENT OF TRANSPORTATION
 BRUNSWICK COUNTY

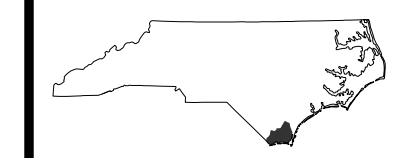

ROADWAY DESIGN UNIT
 ROADWAY DESIGN
 ENGINEER



Signed by:
 Farnell Nelson
 42849488
 CIVIL ENGINEER

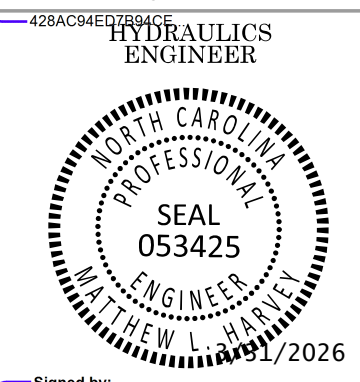

Signed by:
 Matthew Harvey
 42849488
 CIVIL ENGINEER



WE Design your Tomorrow ...
 1223 Jones Franklin Road
 Raleigh, NC 27606
 (919) 851-8077
 NC License F-0377

DOCUMENT NOT CONSIDERED FINAL
 UNLESS ALL SIGNATURES COMPLETED

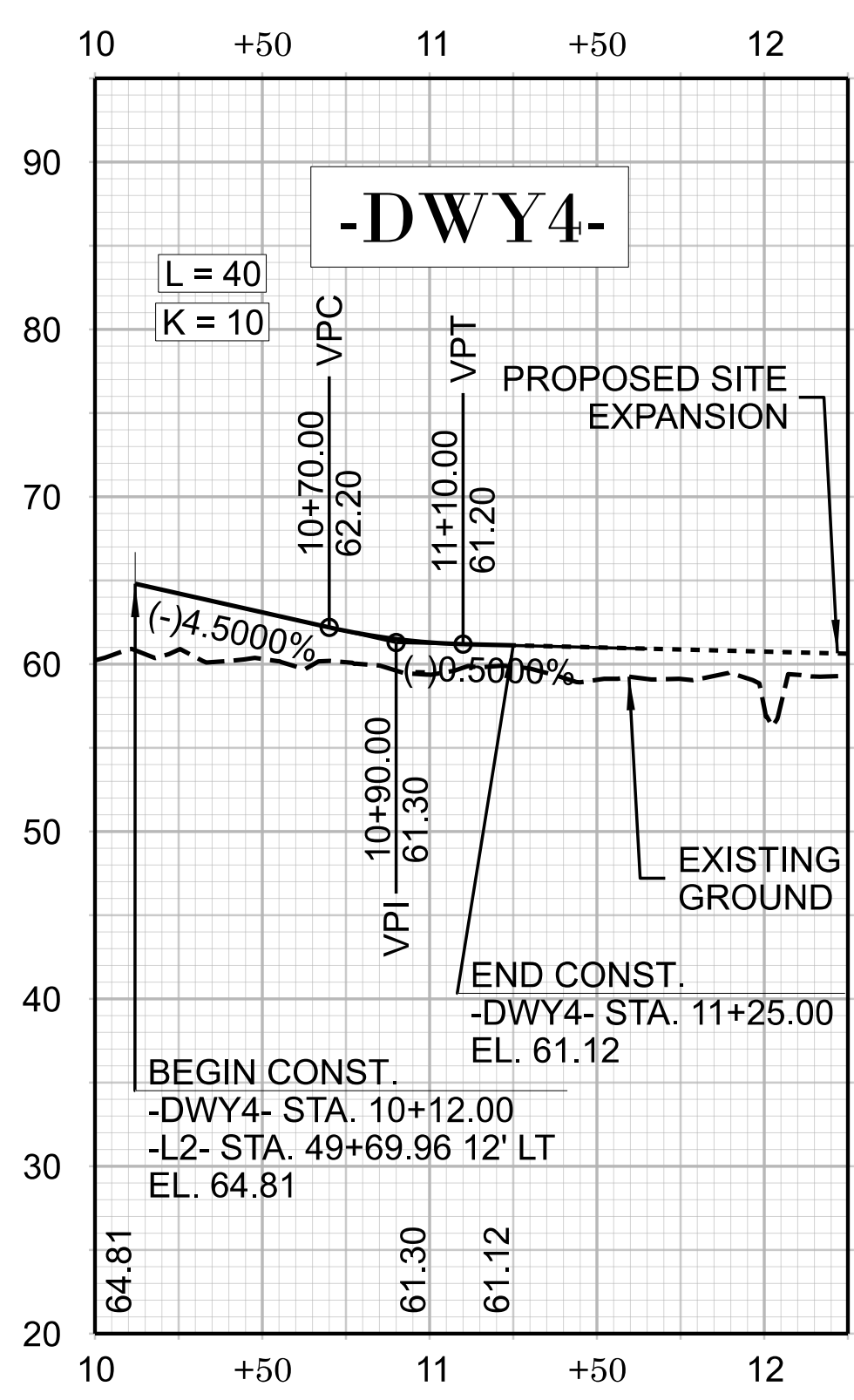
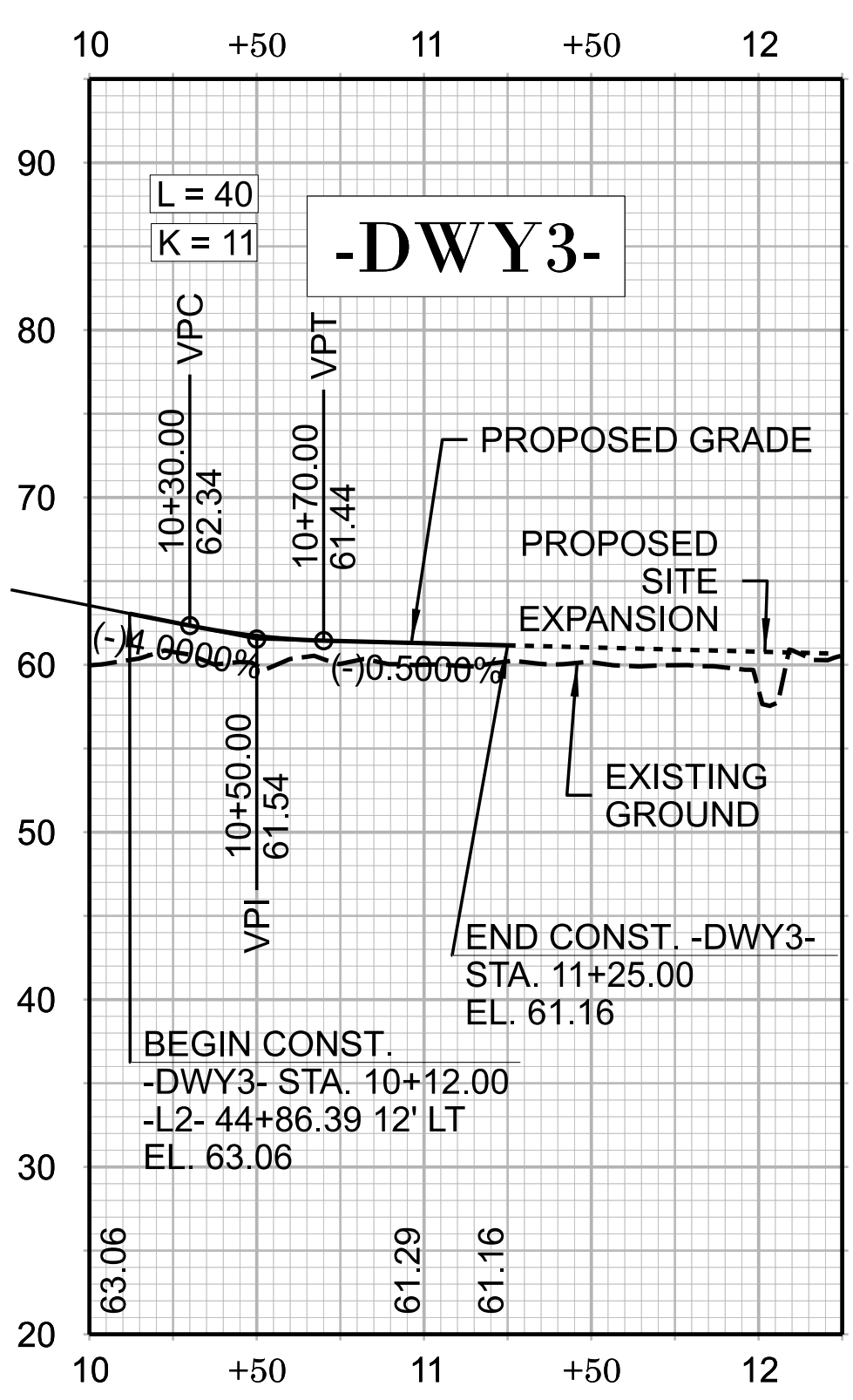
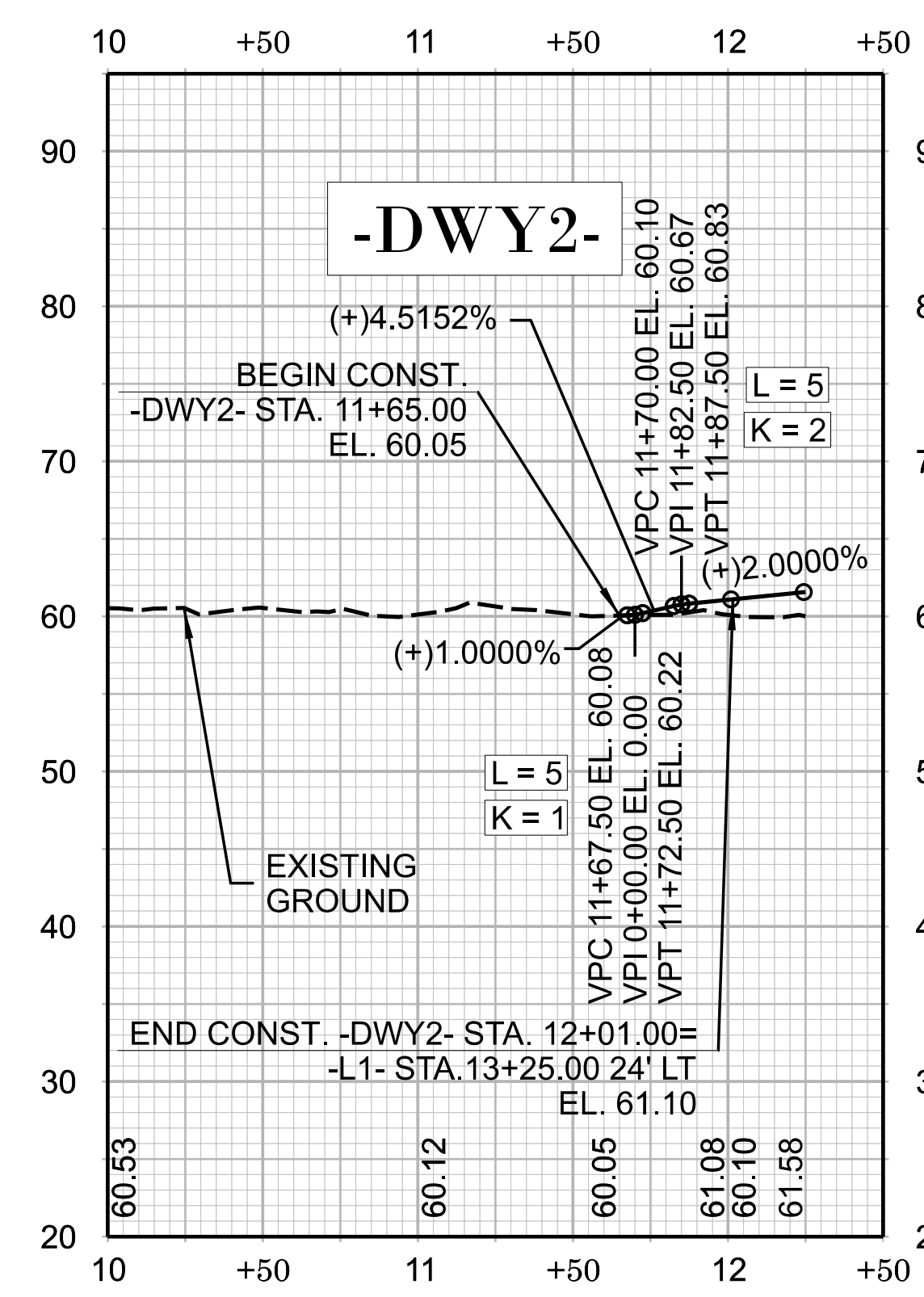
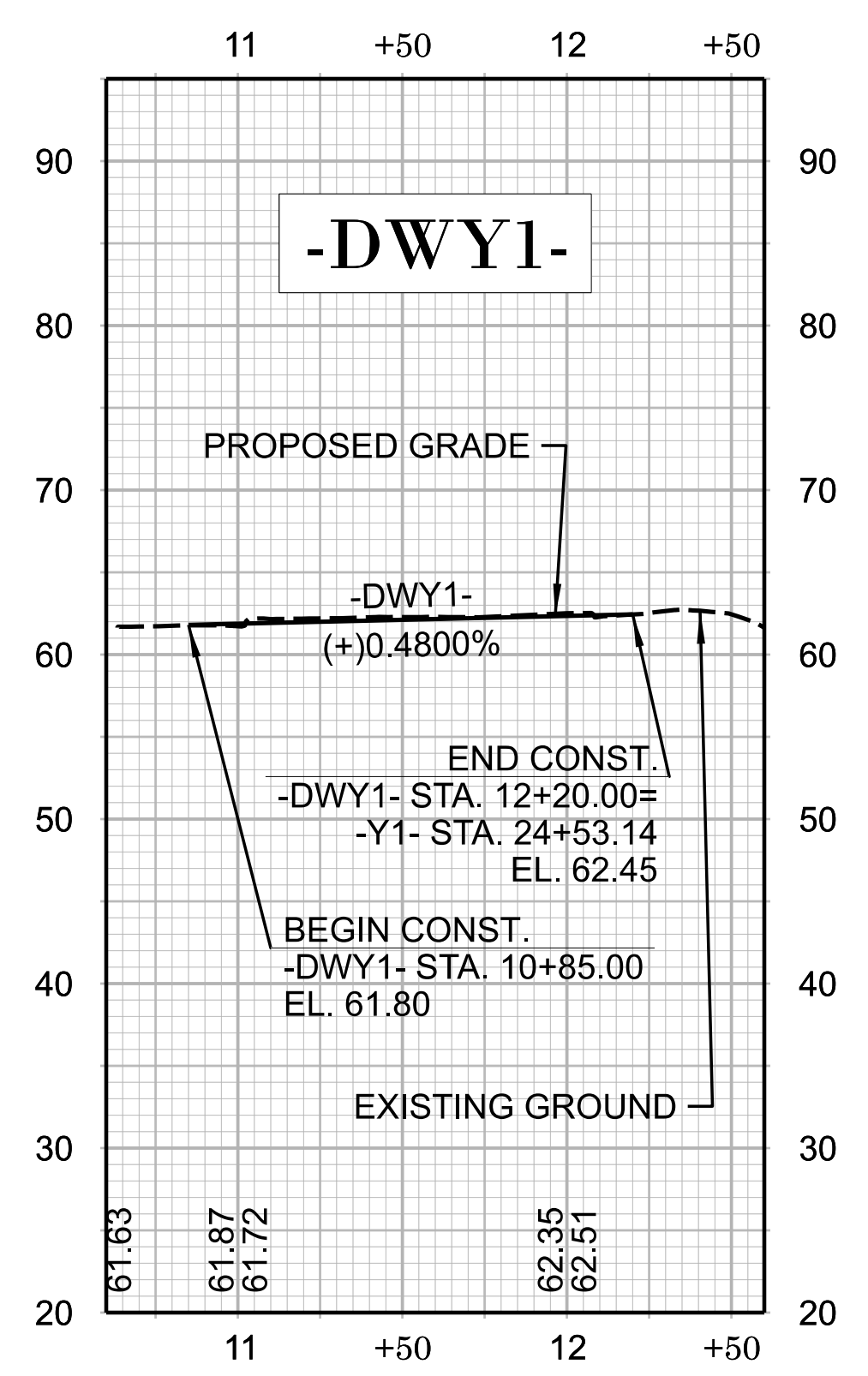

FOR -DWY3-, CONTRACTOR CAN TIE DOWN WITH A TEMPORARY 3:1 AT END OF CONSTRUCTION IF NEEDED UNTIL SITE EXPANSION CONTRACTOR IS READY.

FOR -DWY4-, CONTRACTOR CAN TIE DOWN WITH A TEMPORARY 3:1 AT END OF CONSTRUCTION IF NEEDED UNTIL SITE EXPANSION CONTRACTOR IS READY.

- FOR -DWY1- PLAN, SEE SHEET 4
- FOR -DWY2- PLAN, SEE SHEET 4
- FOR -DWY3- PLAN, SEE SHEET 7
- FOR -DWY4- PLAN, SEE SHEET 7

HE-0016
RDY 19

NORTH CAROLINA
DEPARTMENT OF TRANSPORTATION
BRUNSWICK COUNTY

ROADWAY DESIGN UNIT
ROADWAY DESIGN
ENGINEER

Seal: **Farrell McDaniel**
Professional Engineer
SEAL 045691
DATE: 11/14/2026

Signed by: **Farrell McDaniel**
Professional Engineer

Seal: **Matthew Haney**
Professional Engineer
SEAL 053425
DATE: 11/14/2026

Signed by: **Matthew Haney**
Professional Engineer

WETHERILL
ENGINEERING

WE Design your Tomorrow ...
1223 Jones Franklin Road
Raleigh, NC 27606
(919) 851-8077
NC License F-0377

DOCUMENT NOT CONSIDERED FINAL
UNLESS ALL SIGNATURES COMPLETED