

STATE OF NORTH CAROLINA
DEPARTMENT OF TRANSPORTATION
RALEIGH, N.C.

PROPOSAL

DATE AND TIME OF BID OPENING: **May 19, 2026 AT 02:00 PM**

CONTRACT ID C205106
WBS 67004.3.1

FEDERAL-AID NO. STATE FUNDED
COUNTY HYDE, BEAUFORT
T.I.P NO. BR-0004
MILES 0.521
ROUTE NO. US-264
LOCATION BRIDGE #060066 OVER PUNGO RIVER ON US-264.

TYPE OF WORK GRADING, DRAINAGE, PAVING, AND STRUCTURE.

NOTICE:

ALL BIDDERS SHALL COMPLY WITH ALL APPLICABLE LAWS REGULATING THE PRACTICE OF GENERAL CONTRACTING AS CONTAINED IN CHAPTER 87 OF THE GENERAL STATUTES OF NORTH CAROLINA WHICH REQUIRES THE BIDDER TO BE LICENSED BY THE N.C. LICENSING BOARD FOR CONTRACTORS WHEN BIDDING ON ANY NON-FEDERAL AID PROJECT WHERE THE BID IS \$30,000 OR MORE, EXCEPT FOR CERTAIN SPECIALTY WORK AS DETERMINED BY THE LICENSING BOARD. BIDDERS SHALL ALSO COMPLY WITH ALL OTHER APPLICABLE LAWS REGULATING THE PRACTICES OF ELECTRICAL, PLUMBING, HEATING AND AIR CONDITIONING AND REFRIGERATION CONTRACTING AS CONTAINED IN CHAPTER 87 OF THE GENERAL STATUTES OF NORTH CAROLINA. NOTWITHSTANDING THESE LIMITATIONS ON BIDDING, THE BIDDER WHO IS AWARDED ANY FEDERAL - AID FUNDED PROJECT SHALL COMPLY WITH CHAPTER 87 OF THE GENERAL STATUTES OF NORTH CAROLINA FOR LICENSING REQUIREMENTS WITHIN 60 CALENDAR DAYS OF BID OPENING.

BIDS WILL BE RECEIVED AS SHOWN BELOW:

THIS IS A ROADWAY & STRUCTURE PROPOSAL

5% BID BOND OR BID DEPOSIT REQUIRED

**PROPOSAL FOR THE CONSTRUCTION OF
CONTRACT No. C205106 IN BEAUFORT AND HYDE COUNTIES, NORTH CAROLINA
DEPARTMENT OF TRANSPORTATION,
RALEIGH, NORTH CAROLINA**

The Bidder has carefully examined the location of the proposed work to be known as Contract No. **C205106** has carefully examined the plans and specifications, which are acknowledged to be part of the proposal, the special provisions, the proposal, the form of contract, and the forms of contract payment bond and contract performance bond; and thoroughly understands the stipulations, requirements and provisions. The undersigned bidder agrees to bound upon his execution of the bid and subsequent award to him by the Board of Transportation in accordance with this proposal to provide the necessary contract payment bond and contract performance bond within fourteen days after the written notice of award is received by him. The undersigned Bidder further agrees to provide all necessary machinery, tools, labor, and other means of construction; and to do all the work and to furnish all materials, except as otherwise noted, necessary to perform and complete the said contract in accordance with the *2024 Standard Specifications for Roads and Structures* by the dates(s) specified in the Project Special Provisions and in accordance with the requirements of the Engineer, and at the unit or lump sum prices, as the case may be, for the various items given on the sheets contained herein.

The Bidder shall provide and furnish all the materials, machinery, implements, appliances and tools, and perform the work and required labor to construct and complete Contract No. **C205106** in **Beaufort and Hyde Counties**, for the unit or lump sum prices, as the case may be, bid by the Bidder in his bid and according to the proposal, plans, and specifications prepared by said Department, which proposal, plans, and specifications show the details covering this project, and hereby become a part of this contract.

The published volume entitled *North Carolina Department of Transportation, Raleigh, Standard Specifications for Roads and Structures, January 2024* with all amendments and supplements thereto, is by reference incorporated into and made a part of this contract; that, except as herein modified, all the construction and work included in this contract is to be done in accordance with the specifications contained in said volume, and amendments and supplements thereto, under the direction of the Engineer.

If the proposal is accepted and the award is made, the contract is valid only when signed either by the Contract Officer or such other person as may be designated by the Secretary to sign for the Department of Transportation. The conditions and provisions herein cannot be changed except over the signature of the said Contract Officer.

The quantities shown in the itemized proposal for the project are considered to be approximate only and are given as the basis for comparison of bids. The Department of Transportation may increase or decrease the quantity of any item or portion of the work as may be deemed necessary or expedient.

An increase or decrease in the quantity of an item will not be regarded as sufficient ground for an increase or decrease in the unit prices, nor in the time allowed for the completion of the work, except as provided for the contract.

Accompanying this bid is a bid bond secured by a corporate surety, or certified check payable to the order of the Department of Transportation, for five percent of the total bid price, which deposit is to be forfeited as liquidated damages in case this bid is accepted and the Bidder shall fail to provide the required payment and performance bonds with the Department of Transportation, under the condition of this proposal, within 14 calendar days after the written notice of award is received by him, as provided in the *Standard Specifications*; otherwise said deposit will be returned to the Bidder.



*State Proposals and
Specifications Engineer*

Signed by:

Jeffrey J. Renn

F435514469A145A...

04/15/2026

TABLE OF CONTENTS

**COVER SHEET
PROPOSAL SHEET**

PROJECT SPECIAL PROVISIONS

HAUL ROADS:..... G-1
 CONTRACT TIME AND LIQUIDATED DAMAGES: G-1
 INTERMEDIATE CONTRACT TIME NUMBER 1 AND LIQUIDATED DAMAGES: G-1
 INTERMEDIATE CONTRACT TIME NUMBER 2 AND LIQUIDATED DAMAGES: G-2
 INTERMEDIATE CONTRACT TIME NUMBER 3 AND LIQUIDATED DAMAGES: G-3
 PERMANENT VEGETATION ESTABLISHMENT:..... G-4
 DELAY IN RIGHT OF ENTRY:..... G-4
 MAJOR CONTRACT ITEMS: G-5
 SPECIALTY ITEMS:..... G-5
 FUEL PRICE ADJUSTMENT:..... G-5
 STEEL PRICE ADJUSTMENT:..... G-7
 SCHEDULE OF ESTIMATED COMPLETION PROGRESS:..... G-18
 MINORITY BUSINESS ENTERPRISE AND WOMEN BUSINESS ENTERPRISE:..... G-18
 RESTRICTIONS ON ITS EQUIPMENT AND SERVICES:..... G-34
 USE OF UNMANNED AIRCRAFT SYSTEM (UAS): G-34
 EQUIPMENT IDLING GUIDELINES:..... G-34
 SUBSURFACE INFORMATION:..... G-35
 PORTABLE CONCRETE BARRIER - (Partial Payments for Materials):..... G-35
 REMOVABLE PAVEMENT MARKINGS - (Partial Payments for Materials):..... G-35
 MAINTENANCE OF THE PROJECT: G-36
 TWELVE MONTH GUARANTEE: G-36
 OUTSOURCING OUTSIDE THE USA:..... G-37
 EROSION AND SEDIMENT CONTROL/STORMWATER CERTIFICATION: G-37
 PROCEDURE FOR MONITORING BORROW PIT DISCHARGE:..... G-43
 NOTES TO CONTRACTOR: G-44

ROADWAY.....R-1

STANDARD SPECIAL PROVISIONS

AVAILABILITY OF FUNDS – TERMINATION OF CONTRACTSSSP-1
 NCDOT GENERAL SEED SPECIFICATION FOR SEED QUALITYSSP-2
 ERRATA.....SSP-5
 PLANT AND PEST QUARANTINESSSP-8
 MINIMUM WAGESSSP-9
 TITLE VI AND NONDISCRIMINATION:SSP-10
 ON-THE-JOB TRAINING.....SSP-19

UNIT PROJECT SPECIAL PROVISIONS

GEOTECHNICAL.....GT-1
UTILITY CONSTRUCTION.....UC-1
UTILITY BY OTHERS.....UBO-1
EROSION CONTROLEC-1
STRUCTURE/CULVERTSST-1

PERMITS P-1

PROPOSAL ITEM SHEET

ITEM SHEET(S)

PROJECT SPECIAL PROVISIONS**GENERAL****HAUL ROADS:**

(7-16-24)

105

SP1 G04

Revise the *Standard Specifications* as follows:

Page 1-45, Article 105-15 RESTRICTION OF LOAD LIMITS, line 31, add the following after second sentence of the second paragraph:

At least 30 days prior to use, the Contractor shall notify the Engineer of any public road proposed for use as a haul road for the project.

CONTRACT TIME AND LIQUIDATED DAMAGES:

(8-15-00) (Rev. 5-16-23)

108

SP1 G08 A

The date of availability for this contract is **September 9, 2026**, except that work in jurisdictional waters and wetlands shall not begin until a meeting between the DOT, Regulatory Agencies, and the Contractor is held as stipulated in the permits contained elsewhere in this proposal. This delay in availability has been considered in determining the contract time for this project.

The completion date for this contract is **February 11, 2030**.

Except where otherwise provided by the contract, observation periods required by the contract will not be a part of the work to be completed by the completion date and/or intermediate contract times stated in the contract. The acceptable completion of the observation periods that extend beyond the final completion date shall be a part of the work covered by the performance and payment bonds.

The liquidated damages for this contract are **Two Hundred Dollars (\$ 200.00)** per calendar day. These liquidated damages will not be cumulative with any liquidated damages which may become chargeable under Intermediate Contract Time Number 1.

INTERMEDIATE CONTRACT TIME NUMBER 1 AND LIQUIDATED DAMAGES:

(7-1-95) (Rev. 2-21-12)

108

SP1 G13 A

Except for that work required under the Project Special Provisions entitled *Planting, Reforestation* and/or *Permanent Vegetation Establishment*, included elsewhere in this proposal, the Contractor will be required to complete all work included in this contract and shall place and maintain traffic on same.

The date of availability for this intermediate contract time is **September 9, 2026**.

The completion date for this intermediate contract time is **August 15, 2029**.

The liquidated damages for this intermediate contract time are **Two Thousand Four Hundred Dollars (\$ 2,400.00)** per calendar day.

Upon apparent completion of all the work required to be completed by this intermediate date, a final inspection will be held in accordance with Article 105-17 and upon acceptance, the Department will assume responsibility for the maintenance of all work except *Planting, Reforestation* and/or *Permanent Vegetation Establishment*. The Contractor will be responsible for and shall make corrections of all damages to the completed roadway caused by his planting operations, whether occurring prior to or after placing traffic through the project.

INTERMEDIATE CONTRACT TIME NUMBER 2 AND LIQUIDATED DAMAGES:

(2-20-07)

108

SP1 G14 A

The Contractor shall complete the required work of installing, maintaining, and removing the traffic control devices for lane closures and restoring traffic to the existing traffic pattern. The Contractor shall not close or narrow a lane of traffic on **US 264 (-L-)** during the following time restrictions:

DAY AND TIME RESTRICTIONS

Monday thru Sunday, 6:00 AM to 9:00 AM and 4:00 PM to 7:00 PM

In addition, the Contractor shall not close or narrow a lane of traffic on **US 264 (-L-)**, detain and/or alter the traffic flow on or during holidays, holiday weekends, special events, or any other time when traffic is unusually heavy, including the following schedules:

HOLIDAY AND HOLIDAY WEEKEND LANE CLOSURE RESTRICTIONS

1. For **unexpected occurrence** that creates unusually high traffic volumes, as directed by the Engineer.
2. For **New Year's Day**, between the hours of **6:00 AM** December 31st and **7:00 PM** January 2nd. If New Year's Day is on a Friday, Saturday, Sunday or Monday, then until **7:00 PM** the following Tuesday.
3. For **Easter**, between the hours of **6:00 AM** Thursday and **7:00 PM** Monday.
4. For **Memorial Day**, between the hours of **6:00 AM** Friday and **7:00 PM** Tuesday.
5. For **Independence Day**, between the hours of **6:00 AM** the day before Independence Day and **7:00 PM** the day after Independence Day.

If **Independence Day** is on a Friday, Saturday, Sunday or Monday, then between the hours of **6:00 AM** the Thursday before Independence Day and **7:00 PM** the Tuesday after Independence Day.

6. For **Labor Day**, between the hours of **6:00 AM** Friday and **7:00 PM** Tuesday.
7. For **Thanksgiving**, between the hours of **6:00 AM** Tuesday and **7:00 PM** Monday.
8. For **Christmas**, between the hours of **6:00 AM** the Friday before the week of Christmas Day and **7:00 PM** the following Tuesday after the week of Christmas Day.

Holidays and holiday weekends shall include New Year's, Easter, Memorial Day, Independence Day, Labor Day, Thanksgiving, and Christmas. The Contractor shall schedule his work so that lane closures will not be required during these periods, unless otherwise directed by the Engineer.

The time of availability for this intermediate contract work shall be the time the Contractor begins to install all traffic control devices for lane closures according to the time restrictions listed herein.

The completion time for this intermediate contract work shall be the time the Contractor is required to complete the removal of all traffic control devices for lane closures according to the time restrictions stated above and place traffic in the existing traffic pattern.

The liquidated damages are **Two Hundred Fifty Dollars (\$ 250.00)** per hour.

INTERMEDIATE CONTRACT TIME NUMBER 3 AND LIQUIDATED DAMAGES:

(2-20-07) (Rev. 10-15-13)

108

SPI G14 E

The Contractor shall complete the required work of installing, maintaining and removing the traffic control devices for road closures and restoring traffic to the existing traffic pattern. The Contractor shall not close **US 264 (-L-)** during the following time restrictions:

DAY AND TIME RESTRICTIONS

Monday thru Sunday, 6:00 AM to 9:00 PM and 4:00 AM to 7:00 PM

The maximum allowable time for bridge construction and bridge removal is **thirty (30)** minutes for **US 264 (-L-)**. The Contractor shall reopen the travel lanes to traffic until any resulting traffic queue is depleted.

The time of availability for this intermediate contract time will be the time the Contractor begins to install traffic control devices required for the road closures according to the time restrictions stated herein.

The completion time for this intermediate contract time will be the time the Contractor is required to complete the removal of traffic control devices required for the road closures according to the time restrictions stated herein and restore traffic to the existing traffic pattern.

The liquidated damages are **Two Hundred Fifty Dollars (\$ 250.00)** per fifteen **(15)** minute time period.

PERMANENT VEGETATION ESTABLISHMENT:

(2-16-12)(Rev. 1-16-24)

104

SP1 G16

Establish a permanent stand of the vegetation mixture shown in the contract. During the period between initial vegetation planting and final project acceptance, perform all work necessary to establish permanent vegetation on all erodible areas within the project limits, as well as, in borrow and waste pits. This work shall include erosion control device maintenance and installation, repair seeding and mulching, supplemental seeding and mulching, mowing, and fertilizer topdressing, as directed. All work shall be performed in accordance with the applicable section of the *Standard Specifications*. All work required for initial vegetation planting shall be performed as a part of the work necessary for the completion and acceptance of the Intermediate Contract Time (ICT). Between the time of ICT and Final Project acceptance, or otherwise referred to as the vegetation establishment period, the Department will be responsible for preparing the required National Pollutant Discharge Elimination System (NPDES) inspection records.

Once the Engineer has determined that the permanent vegetation establishment requirement has been achieved at an 80% vegetation density (the amount of established vegetation per given area to stabilize the soil) and no erodible areas exist within the project limits, the Contractor will be notified to remove the remaining erosion control devices that are no longer needed. The Contractor will be responsible for, and shall correct any areas disturbed by operations performed in permanent vegetation establishment and the removal of temporary erosion control measures, whether occurring prior to or after placing traffic on the project.

Payment for *Response for Erosion Control, Seeding and Mulching, Repair Seeding, Supplemental Seeding, Mowing, Fertilizer Topdressing, Silt Excavation, and Stone for Erosion Control* will be made at contract unit prices for the affected items. Work required that is not represented by contract line items will be paid in accordance with Articles 104-7 or 104-3 of the *Standard Specifications*. No additional compensation will be made for maintenance and removal of temporary erosion control items.

DELAY IN RIGHT OF ENTRY:

(7-1-95) (Rev. 7-15-14)

108

SP1 G22

The Contractor will not be allowed right of entry to the following parcel(s) prior to the listed date(s) unless otherwise permitted by the Engineer.

<u>Parcel No.</u>	<u>Property Owner</u>	<u>Date</u>
2	Gilbert R. Stotesberry & wife, Vivian R. Stotesberry & Amanda Rae Stotesberry	04-30-2026
7	Hoon C. Kim	04-30-2026

MAJOR CONTRACT ITEMS:

(2-19-02)(Rev. 1-16-24)

104

SP1 G28

The following listed items are the major contract items for this contract (see Article 104-5 of the *Standard Specifications*):

Line #	Description
130	Reinforced Concrete Deck Slab
135	54" Prestressed Concrete Girders

SPECIALTY ITEMS:

(7-1-95)(Rev. 1-16-24)

108-6

SP1 G37

Items listed below will be the specialty items for this contract (see Article 108-6 of the *Standard Specifications*).

Line #	Description
41-51	Guardrail
55-61	Signing
74-75, 79	Long-Life Pavement Markings
76	Removable Tape
81-82	Permanent Pavement Markers
83-91	Utility Construction
92-119, 122-125	Erosion Control
120-121	Reforestation

FUEL PRICE ADJUSTMENT:

(11-15-05)(Rev. 1-16-24)

109-8

SP1 G43

Page 1-82, Article 109-8, FUEL PRICE ADJUSTMENTS, add the following:

The base index price for DIESEL #2 FUEL is \$ **4.1435** per gallon. Where any of the following are included as pay items in the contract, they will be eligible for fuel price adjustment.

The pay items and the fuel factor used in calculating adjustments to be made will be as follows:

Description	Units	Fuel Usage Factor Diesel
Unclassified Excavation	Gal/CY	0.29
Borrow Excavation	Gal/CY	0.29
Class IV Subgrade Stabilization	Gal/Ton	0.55
Aggregate Base Course	Gal/Ton	0.55
Sub-Ballast	Gal/Ton	0.55
Erosion Control Stone	Gal/Ton	0.55
Rip Rap, Class _____	Gal/Ton	0.55
Asphalt Concrete Base Course, Type _____	Gal/Ton	0.90 or 2.90
Asphalt Concrete Intermediate Course, Type _____	Gal/Ton	0.90 or 2.90
Asphalt Concrete Surface Course, Type _____	Gal/Ton	0.90 or 2.90
Open-Graded Asphalt Friction Course	Gal/Ton	0.90 or 2.90
Permeable Asphalt Drainage Course, Type _____	Gal/Ton	0.90 or 2.90
Sand Asphalt Surface Course, Type _____	Gal/Ton	0.90 or 2.90
Ultra-thin Bonded Wearing Course	Gal/Ton	0.90 or 2.90
Aggregate for Cement Treated Base Course	Gal/Ton	0.55
Portland Cement for Cement Treated Base Course	Gal/Ton	0.55
> 11" Portland Cement Concrete Pavement	Gal/SY	0.327
Concrete Shoulders Adjacent to > 11" Pavement	Gal/SY	0.327
9" to 11" Portland Cement Concrete Pavement	Gal/SY	0.272
Concrete Shoulders Adjacent to 9" to 11" Pavement	Gal/SY	0.272
< 9" Portland Cement Concrete Pavement	Gal/SY	0.245
Concrete Shoulders Adjacent to < 9" Pavement	Gal/SY	0.245

For the asphalt items noted in the chart as eligible for fuel adjustments, the bidder may include the *Fuel Usage Factor Adjustment Form* with their bid submission if they elect to use the fuel usage factor. The *Fuel Usage Factor Adjustment Form* is found at the following link:

<https://connect.ncdot.gov/letting/LetCentral/Fuel%20Usage%20Factor%20Adjustment%20Form%20-%20Starting%20Nov%202022%20Lettings.pdf>

Select either 2.90 Gal/Ton fuel factor or 0.90 Gal/Ton fuel factor for each asphalt line item on the *Fuel Usage Factor Adjustment Form*. The selected fuel factor for each asphalt item will remain in effect for the duration of the contract.

Failure to complete the *Fuel Usage Factor Adjustment Form* will result in using 2.90 gallons per ton as the Fuel Usage Factor for Diesel for the asphalt items noted above. The contractor will not be permitted to change the Fuel Usage Factor after the bids are submitted.

STEEL PRICE ADJUSTMENT:

(4-19-22)(Rev. 12-20-22)

SP1 G47

Description and Purpose

Steel price adjustments will be made to the payments due the Contractor for items as defined herein that are permanently incorporated into the work, when the price of raw steel mill products utilized on the contract have fluctuated. The Department will adjust monthly progress payments up or down as appropriate for cost changes in steel according to this provision.

Eligible Items

The list of eligible bid items for steel price adjustment can be found on the Departments website at the following address:

<https://connect.ncdot.gov/letting/LetCentral/Eligible%20Bid%20Items%20for%20Steel%20Price%20Adjustment.xlsx>

Nuts, bolts, anchor bolts, rebar chairs, connecting bands and other miscellaneous hardware associated with these items shall not be included in the price adjustment.

Adjustments will only be made for fluctuations in the material cost of the steel used in the above products as specified in the Product Relationship Table below. The producing mill is defined as the source of steel product before any fabrication has occurred (e.g., coil, plate, rebar, hot rolled shapes, etc.). No adjustment will be made for changes in the cost of fabrication, coating, shipping, storage, etc.

No steel price adjustments will be made for any products manufactured from steel having an adjustment date, as defined by the Product Relationship Table below, prior to the letting date.

Bid Submittal Requirements

The successful bidder, within 14 calendar days after the notice of award is received by him, shall provide the completed Form SPA-1 to the Department (State Contract Officer or Division Contract Engineer) along with the payment bonds, performance bonds and contract execution signature sheets in a single submittal. If Form SPA-1 is not included in the same submittal as the payment bonds, performance bonds and contract execution signature sheets, the Contractor will not be eligible for any steel price adjustment for any item in the contract for the life of the contract. Form SPA-1 can be found on the Department's website at the following address:

<https://connect.ncdot.gov/letting/LetCentral/Form%20SPA-1.xlsm>

The Contractor shall provide Form SPA-1 listing the Contract Line Number, (with corresponding Item Number, Item Description, and Category) for the steel products they wish to have an adjustment calculated. Only the contract items corresponding to the list of eligible item numbers for steel price adjustment may be entered on Form SPA-1. The Contractor may choose to have steel price adjustment applied to any, all, or none of the eligible items. However, the Contractor's selection of items for steel price adjustment or non-selection (non-participation)

may not be changed once Form SPA-1 has been received by the Department. Items the Bidder chooses for steel price adjustment must be designated by writing the word “Yes” in the column titled “Option” by each Pay Item chosen for adjustment. Should the bidder elect an eligible steel price item, the entire quantity of the line item will be subject to the price adjustment for the duration of the Contract. The Bidder’s designations on Form SPA-1 must be written in ink or typed and signed by the Bidder (Prime Contractor) to be considered complete. Items not properly designated, designated with “No”, or left blank on the Bidder’s Form SPA-1 will automatically be removed from consideration for adjustment. No steel items will be eligible for steel price adjustment on this Project if the Bidder fails to return Form SPA-1 in accordance with this provision.

Establishing the Base Price

The Department will use a blend of monthly average prices as reported from the Fastmarkets platform to calculate the monthly adjustment indices (BI and MI). This data is typically available on the first day of the month for the preceding month. The indices will be calculated by the Department for the different categories found on the Product Relationship Table below. For item numbers that include multiple types of steel products, the category listed for that item number will be used for adjusting each steel component.

The bidding index for Category 1 Steel items is **\$ 47.25** per hundredweight.
The bidding index for Category 2 Steel items is **\$ 58.72** per hundredweight.
The bidding index for Category 3 Steel items is **\$ 74.93** per hundredweight.
The bidding index for Category 4 Steel items is **\$ 51.91** per hundredweight.
The bidding index for Category 5 Steel items is **\$ 57.81** per hundredweight.
The bidding index for Category 6 Steel items is **\$ 69.57** per hundredweight.
The bidding index for Category 7 Steel items is **\$ 50.03** per hundredweight.

The bidding index represents a selling price of steel based on Fastmarkets data for the month of **March 2026**.

- MI = Monthly Index. – in Dollars (\$) per hundredweight (CWT). Use the adjustment indices from the month the steel was shipped from the producing mill, received on the project, or member cast as defined in the Product Relationship Table.
- BI = Bidding Index. - in Dollars (\$) per hundredweight (CWT). Use the adjustment indices as listed in the proposal.

Product Relationship Table

<i>Steel Product (Title)</i>	BI, MI*	Adjustment Date for MI	Category
Reinforcing Steel, Bridge Deck, and SIP Forms	Based on one or more Fastmarkets indices	Delivery Date from Producing Mill	1
Structural Steel and Encasement Pipe	Based on one or more Fastmarkets indices	Delivery Date from Producing Mill	2
Steel H-Piles, Soldier Pile Walls	Based on one or more Fastmarkets indices	Delivery Date from Producing Mill	3
Guardrail Items and Pipe Piles	Based on one or more Fastmarkets indices	Material Received Date**	4
Fence Items	Based on one or more Fastmarkets indices	Material Received Date**	5
Overhead Sign Assembly, Signal Poles, High Mount Standards	Based on one or more Fastmarkets indices	Material Received Date**	6
Prestressed Concrete Members	Based on one or more Fastmarkets indices	Cast Date of Member	7

* BI and MI are in converted units of Dollars per Hundredweight (\$/CWT)

** Material Received Date is defined as the date the materials are received on the project site. If a material prepayment is made for a Category 4-6 item, the Adjustment Date to be used will be the date of the prepayment request instead of the Materials Received Date.

Submit documentation to the Engineer for all items listed in the Contract for which the Contractor is requesting a steel price adjustment.

Submittal Requirements

The items in categories 1,2, and 3, shall be specifically stored, labeled, or tagged, recognizable by color marking, and identifiable by Project for inspection and audit verification immediately upon arrival at the fabricator.

Furnish the following documentation for all steel products to be incorporated into the work and documented on Form SPA-2, found on the Departments website at the following address:

<https://connect.ncdot.gov/projects/construction/Construction%20Forms/Form%20SPA-2.xlsx>

Submit all documentation to the Engineer prior to incorporation of the steel into the completed work. The Department will withhold progress payments for the affected contract line item if the documentation is not provided and at the discretion of the Engineer the work is allowed to proceed. Progress payments will be made upon receipt of the delinquent documentation.

Step 1 (Form SPA -2)

Utilizing Form SPA-2, submit separate documentation packages for each line item from Form SPA-1 for which the Contractor opted for a steel price adjustment. For line items with multiple components of steel, each component should be listed separately. Label each SPA-2 documentation package with a unique number as described below.

- a. Documentation package number: (Insert the contract line-item) - (Insert sequential package number beginning with "1").
Example: 412 - 1,
 412 - 2,
 424 - 1,
 424 - 2,
 424 - 3, etc.
- b. The steel product quantity in pounds
 - i. The following sources should be used, in declining order of precedence, to determine the weight of steel/iron, based on the Engineers decision:
 1. Department established weights of steel/iron by contract pay item per pay unit;
 2. Approved Shop Drawings;
 3. Verified Shipping Documents;
 4. Contract Plans;
 5. Standard Drawing Sheets;
 6. Industry Standards (i.e., AISC Manual of Steel Construction, AWWA Standards, etc.); and
 7. Manufacture's data.
 - ii. Any item requiring approved shop drawings shall have the weights of steel calculated and shown on the shop drawings or submitted and certified separately by the fabricator.
- c. The date the steel product, subject to adjustment, was shipped from the producing mill (Categories 1-3), received on the project (Categories 4-6), or casting date (Category 7).

Step 2 (Monthly Calculator Spreadsheet)

For each month, upon the incorporation of the steel product into the work, provide the Engineer the following:

- 1) Completed NCDOT Steel Price Adjustment Calculator Spreadsheet, summarizing all the steel submittal packages (Form SPA-2) actually incorporated into the completed work in the given month.
 - a. Contract Number
 - b. Bidding Index Reference Month
 - c. Contract Completion Date or Revised Completion Date
 - d. County, Route, and Project TIP information
 - e. Item Number
 - f. Line-Item Description
 - g. Submittal Number from Form SPA-2
 - h. Adjustment date
 - i. Pounds of Steel

- 2) An affidavit signed by the Contractor stating the documentation provided in the NCDOT Steel Price Adjustment Calculator Spreadsheet is true and accurate.

Price Adjustment Conditions

Download the Monthly Steel Adjustment Spreadsheet with the most current reference data from the Department's website each month at the following address:

<https://connect.ncdot.gov/projects/construction/Construction%20Forms/Form%20SPA-3%20NCDOT%20Steel%20Price%20Adjustment%20Calculator.xlsx>

If the monthly Fastmarkets data is not available, the data for the most recent immediately preceding month will be used as the basis for adjustment.

Price Adjustment Calculations

The price adjustment will be determined by comparing the percentage of change in index value listed in the proposal (BI) to the monthly index value (MI). (See included sample examples). Weights and date of shipment must be documented as required herein. The final price adjustment dollar value will be determined by multiplying this percentage increase or decrease in the index by the represented quantity of steel incorporated into the work, and the established bidding index (BI) subject to the limitations herein.

Price increase/decrease will be computed as follows:

$$\text{SPA} = ((\text{MI} / \text{BI}) - 1) * \text{BI} * (\text{Q} / 100)$$

Where;

SPA = Steel price adjustment in dollars

MI = Monthly Shipping Index. – in Dollars (\$) per hundredweight (CWT). Use the adjustment indices from the month the steel was shipped from the producing mill, received on the project, or member cast as defined in the Product Relationship Table.

BI = Bidding Index. - in Dollars (\$) per hundredweight (CWT). Use the adjustment indices as listed in the proposal.

Q = Quantity of steel, product, pounds actually incorporated into the work as documented by the Contractor, or Design Build Team and verified by the Engineer.

Calculations for price adjustment shall be shown separate from the monthly progress estimate and will not be included in the total cost of work for determination of progress or for extension of Contract time in accordance with Subarticle 108-10(B)(1).

Any apparent attempt to unbalance bids in favor of items subject to price adjustment may result in rejection of the bid proposal.

Adjustments will be paid or charged to the Contractor only. Any Contractor receiving an adjustment under this provision shall distribute the proper proportional part of such adjustments to the subcontractor who performed the applicable work.

Delays to the work caused by steel shortages may be justification for a Contract time extension but will not constitute grounds for claims for standby equipment, extended office overhead, or other costs associated with such delays.

If an increase in the steel material price is anticipated to exceed 50% of the original quoted price, the contractor must notify the Department within 7 days prior to purchasing the material. Upon receipt of such notification, the Department will direct the Contractor to either (1) proceed with the work or (2) suspend the work and explore the use of alternate options.

If the decrease in the steel material exceeds 50% of the original quoted price, the contractor may submit to the Department additional market index information specific to the item in question to dispute the decrease. The Department will review this information and determine if the decrease is warranted.

When the steel product adjustment date, as defined in the Product Relationship Table, is after the approved contract completion date, the steel price adjustments will be based on the lesser value of either the MI for the month of the approved contract completion date or the MI for the actual adjustment date.

If the price adjustment is based on estimated material quantities for that time, and a revision to the total material quantity is made in a subsequent or final estimate, an appropriate adjustment will be made to the price adjustment previously calculated. The adjustment will be based on the same indices used to calculate the price adjustment which is being revised. If the adjustment date of the revised material quantity cannot be determined, the adjustment for the quantity in question, will be based on the indices utilized to calculate the steel price adjustment for the last initial documentation package submission, for the steel product subject to adjustment, that was incorporated into the particular item of work, for which quantities are being finalized.

Example: Structural steel for a particular bridge was provided for in three different shipments with each having a different mill shipping date. The quantity of structural steel actually used for the bridge was calculated and a steel price adjustment was made in a progress payment. At the conclusion of the work an error was found in the plans of the final quantity of structural steel used for the bridge. The quantity to be adjusted cannot be directly related to any one of the three mill shipping dates. The steel price adjustment for the quantity in question would be calculated using the indices that were utilized to calculate the steel price adjustment for the quantity of structural steel represented by the last initial structural steel documentation package submission. The package used will be the one with the greatest sequential number.

Extra Work/Force Account:

When steel products, as specified herein, are added to the contract as extra work, in accordance with the provisions of Article 104-7 or 104-3, the Engineer will determine and specify in the supplemental agreement, the need for application of steel price adjustments on a case-by-case basis. No steel price adjustments will be made for any products manufactured from steel having an adjustment date prior to the supplemental agreement execution date. Price adjustments will be made as provided herein, except the Bidding Index will be based on the month in which the supplemental agreement pricing was executed.

For work performed on force account basis, reimbursement of actual material costs, along with the specified overhead and profit markup, will be considered to include full compensation for the current cost of steel and no steel price adjustments will be made.

Examples Form SPA-2

Steel Price Adjustment Submission Form

Contract Number C203394 Bid Reference Month January 2019

Submittal Date 8/31/2019

Contract Line Item 237

Line Item Description APPROX....LBS Structural Steel

Sequential Submittal Number 2

Supplier	Description of material	Location information	Quantity in lbs.	Adjustment Date
XYZ mill	Structural Steel	Structure 3, Spans A-C	1,200,000	May 4, 2020
ABC distributing	Various channel & angle shapes	Structure 3 Spans A-C	35,000	July 14, 2020
		Total Pounds of Steel	1,235,000	

- Note: Attach the following supporting documentation to this form.
- Bill of Lading to support the shipping dates
 - Supporting information for weight documentation (e.g., Pay item reference, Shop drawings, shipping documents, Standards Sheets, industry standards, or manufacturer's data)

By providing this data under my signature, I attest to the accuracy of and validity of the data on this form and certify that no deliberate misrepresentation in any manner has occurred.

Printed Name

Signature

Examples Form SPA-2
Steel Price Adjustment Submission Form

Contract Number C203394 Bid Reference Month January 2019

Submittal Date August 31, 2019

Contract Line Item 237

Line Item Description SUPPORT, OVRHD SIGN STR -DFEB – STA 36+00

Sequential Submittal Number 2

Supplier	Description of material	Location information	Quantity in lbs.	Adjustment Date
XYZ mill	Tubular Steel (Vertical legs)	<u>-DFEB – STA 36+00</u>	12000	December 11, 2021
PDQ Mill	4” Tubular steel (Horizontal legs)	<u>-DFEB – STA 36+00</u>	5900	December 11, 2021
ABC distributing	Various channel & angle shapes (see quote)	<u>-DFEB – STA 36+00</u>	1300	December 11, 2021
	Catwalk assembly	<u>-DFEB – STA 36+00</u>	2000	December 11, 2021
Nucor	Flat plate	<u>-DFEB – STA 36+00</u>	650	December 11, 2021
		Total Pounds of Steel	21,850	

Note: Attach the following supporting documentation to this form.

- Bill of Lading to support the shipping dates
- Supporting information for weight documentation (e.g., Pay item reference, Shop drawings, shipping documents, Standards Sheets, industry standards, or manufacturer's data)

By providing this data under my signature, I attest to the accuracy of and validity of the data on this form and certify that no deliberate misrepresentation in any manner has occurred.

Printed Name

Signature

Price Adjustment Sample Calculation (increase)

Project bid on September 17, 2019

Line Item 635 “Structural Steel” has a plan quantity of 2,717,000 lbs.

Bidding Index for Structural Steel (Category 2) in the proposal was \$36.12/CWT = BI

450,000 lbs. of Structural Steel for Structure 2 at Station 44+08.60 were shipped to fabricator from the producing mill in same month, May 2021.

Monthly Index for Structural Steel (Category 2) for May 2021 was \$64.89/CWT = MI

The Steel Price Adjustment formula is as follows:

$$\text{SPA} = ((\text{MI} / \text{BI}) - 1) * \text{BI} * (\text{Q} / 100)$$

Where; SPA = Steel price adjustment in dollars

BI = Bidding Index – in dollars (\$) per hundredweight (CWT). Use the adjustment indices as listed in the proposal.

MI = Mill Shipping Index – in dollars (\$) per hundredweight (CWT). Use the adjustment indices from the month the steel was shipped from the producing mill, received on the project, or member cast as defined in the Product Relationship Table.

Q = Quantity of steel product, in pounds (lbs.) actually incorporated into the work as documented by the Contractor, or Design Build Team and verified by the Engineer.

$$\text{BI} = \$36.12 / \text{CWT}$$

$$\text{MI} = \$64.89 / \text{CWT}$$

$$\% \text{ change} = ((\text{MI} / \text{BI}) - 1) = (\$64.89 / \$36.12 - 1) = (1.79651 - 1) = 0.79651162791$$

$$\text{Q} = 450,000 \text{ lbs.}$$

$$\text{SPA} = 0.79651162791 \times \$36.12 \times (450,000 / 100)$$

$$\text{SPA} = 0.79651162791 * \$36.12 * 4,500$$

$$\text{SPA} = \$129,465 \text{ pay adjustment to Contractor for Structural Steel (Structure 2 at Station 44+08.60)}$$

Price Adjustment Sample Calculation (decrease)

Project bid on December 18, 2018

Line Item 635 Structural Steel has a plan quantity of 2,717,000 lbs.

Bidding Index for Structural Steel (Category 2) in the proposal was \$46.72/CWT = BI

600,000 lbs. of Structural Steel for Structure 1 at Station 22+57.68 were shipped to fabricator from the producing mill in same month, August 2020.

Monthly Index for Structural Steel (Category 2) for August 2020 was \$27.03/CWT = MI

The Steel Price Adjustment formula is as follows:

$$\text{SPA} = ((\text{MI} / \text{BI}) - 1) * \text{BI} * (\text{Q} / 100)$$

Where; SPA = Steel price adjustment in dollars

BI = Bidding Index – in dollars (\$) per hundredweight (CWT). Use the adjustment indices as listed in the proposal.

MI = Mill Shipping Index – in dollars (\$) per hundredweight (CWT). Use the adjustment indices from the month the steel was shipped from the producing mill, received on the project, or member cast as defined in the Product Relationship Table.

Q = Quantity of steel product, in pounds (lbs.) actually incorporated into the work as documented by the Contractor, or Design Build Team and verified by the Engineer.

$$\text{BI} = \$46.72 / \text{CWT}$$

$$\text{MI} = \$27.03 / \text{CWT}$$

$$\% \text{ change} = ((\text{MI} / \text{BI}) - 1) = (\$27.03 / \$46.72 - 1) = (0.57855 - 1) = -0.421446917808$$

$$\text{Q} = 600,000 \text{ lbs.}$$

$$\text{SPA} = -0.421446917808 * \$46.72 * (600,000 / 100)$$

$$\text{SPA} = -0.421446917808 * \$46.72 * 6,000$$

$$\text{SPA} = \$ 118,140.00 \text{ Credit to the Department for Structural Steel (Structure 1 at Station 22+57.68)}$$

Price Adjustment Sample Calculation (increase)

Project bid on July 16, 2020

Line Item 614 Reinforced Concrete Deck Slab has a plan quantity of 241974 lbs.

Bidding Index Reference Month was May 2020. Bidding Index for Reinforced Concrete Deck Slab (Category 1) in the proposal was \$29.21/CWT = BI

51,621 lbs. of reinforcing steel and 52,311 lbs. of epoxy coated reinforcing steel for Structure 2 at Station 107+45.55 -L- was shipped to fabricator from the producing mill in same month, May 2021.

Monthly Index for Reinforced Concrete Deck Slab (Category 1) for May 2021 was \$43.13/CWT = MI

The Steel Price Adjustment formula is as follows:

$$\text{SPA} = ((\text{MI} / \text{BI}) - 1) * \text{BI} * (\text{Q} / 100)$$

Where; SPA = Steel price adjustment in dollars

BI = Bidding Index – in dollars (\$) per hundredweight (CWT). Use the adjustment indices as listed in the proposal.

MI = Mill Shipping Index – in dollars (\$) per hundredweight (CWT). Use the adjustment indices from the month the steel was shipped from the producing mill, received on the project, or member cast as defined in the Product Relationship Table.

Q = Quantity of steel product, in pounds (lbs.) actually incorporated into the work as documented by the Contractor, or Design Build Team and verified by the Engineer.

$$\text{BI} = \$29.21 / \text{CWT}$$

$$\text{MI} = \$43.13 / \text{CWT}$$

$$\% \text{ change} = ((\text{MI} / \text{BI}) - 1) = (\$43.13 / \$29.21 - 1) = (1.47655 - 1) = 0.47654912701$$

$$\text{Q} = 103932 \text{ lbs.}$$

$$\text{SPA} = 0.47654912701 * \$29.21 * (103,932 / 100)$$

$$\text{SPA} = 0.47654912701 * \$29.21 * 1,039.32$$

SPA = \$14,467.33 Pay Adjustment to Contractor for Reinforced Concrete Deck Slab (Category 1) at Station 107+45.55 -L-

SCHEDULE OF ESTIMATED COMPLETION PROGRESS:

(7-15-08)(Rev. 6-17-25)

108-2

SP1 G58

The Contractor's attention is directed to the Standard Special Provision entitled *Availability of Funds Termination of Contracts* included elsewhere in this proposal. The Department of Transportation's schedule of estimated completion progress for this project as required by that Standard Special Provision is as follows:

	<u>Fiscal Year</u>	<u>Progress (% of Dollar Value)</u>
2027	(7/01/26 - 6/30/27)	37% of Total Amount Bid
2028	(7/01/27 - 6/30/28)	39% of Total Amount Bid
2029	(7/01/28 - 6/30/29)	22% of Total Amount Bid
2030	(7/01/29 - 6/30/30)	2% of Total Amount Bid

The Contractor shall also furnish his own progress schedule in accordance with Article 108-2 of the *Standard Specifications*. Any acceleration of the progress as shown by the Contractor's progress schedule over the progress as shown above shall be subject to the approval of the Engineer.

MINORITY BUSINESS ENTERPRISE AND WOMEN BUSINESS ENTERPRISE:

(10-16-07)(Rev. 10-21-25)

102-15(J)

SP1 G66

Description

The purpose of this Special Provision is to carry out the North Carolina Department of Transportation's policy of ensuring nondiscrimination in the award and administration of contracts financed in whole or in part with State funds.

Definitions

Additional MBE/WBE Subcontractors - Any MBE/WBE submitted at the time of bid that will not be used to meet the Combined MBE /WBE Goal. No submittal of a Letter of Intent is required.

Combined MBE/WBE Goal: A portion of the total contract, expressed as a percentage that is to be performed by committed MBE/WBE subcontractors.

Committed MBE/WBE Subcontractor - Any MBE/WBE submitted at the time of bid that is being used to meet the Combined MBE /WBE goal by submission of a Letter of Intent. Or any MBE or WBE used as a replacement for a previously committed MBE or WBE firm.

Contract Goal Requirement - The approved participation at time of award, but not greater than the advertised Combined MBE/WBE contract goal.

Goal Confirmation Letter - Written documentation from the Department to the bidder confirming the Contractor's approved, committed participation along with a listing of the committed MBE and WBE firms.

Manufacturer - A firm that owns (or leases) and operates or maintains a factory or establishment that produces on the premises, the materials or supplies obtained by the Contractor. A firm that makes minor modifications to the materials, supplies, articles, or equipment is not a manufacturer.

MBE Participation (Anticipated) - A portion of the total contract, expressed as a percentage that is anticipated to be performed by committed MBE subcontractor(s).

Minority Business Enterprise (MBE) - A firm certified as a Disadvantaged Minority-Owned Business Enterprise through the North Carolina Unified Certification Program.

Regular Dealer - A firm that owns (or leases), and operates a store, warehouse, or other establishment in which the materials or supplies required for the performance of the contract are bought, kept in sufficient quantities, and regularly sold to the public in the usual course of business. A regular dealer engages in, as its principal business and in its own name, the purchase and sale or lease of the products in question. A regular dealer in such bulk items as steel, concrete or concrete products, gravel, stone, asphalt and petroleum products need not keep such products in stock, if it owns and operates distribution equipment for the products. Any supplement of regular dealers' own distribution equipment shall be by a long-term operating lease and not on an ad hoc or contract-by-contract basis.

Distributor - A firm that engages in the regular sale or lease of the items specified by the contract. A distributor assumes responsibility for the items it purchases once they leave the point of origin (e.g., a manufacturer's facility), making it liable for any loss or damage not covered by the carrier's insurance.

Replacement / Substitution - A full or partial reduction in the amount of work subcontracted to a committed (or an approved substitute) MBE/WBE firm.

North Carolina Unified Certification Program (NCUCP) - A program that provides comprehensive services and information to applicants for MBE/WBE certification. The MBE/WBE program follows the same regulations as the federal Disadvantaged Business Enterprise (DBE) program in accordance with 49 CFR Part 26.

United States Department of Transportation (USDOT) - Federal agency responsible for issuing regulations (49 CFR Part 26) and official guidance for the DBE program.

WBE Participation (Anticipated) - A portion of the total contract, expressed as a percentage, that is anticipated to be performed by committed WBE subcontractor(s).

Women Business Enterprise (WBE) - A firm certified as a Disadvantaged Women-Owned Business Enterprise through the North Carolina Unified Certification Program.

Forms and Websites Referenced in this Provision

Payment Tracking System - On-line system in which the Contractor enters the payments made to MBE and WBE subcontractors who have performed work on the project.
<https://apps.dot.state.nc.us/Vendor/PaymentTracking/>

DBE-IS Subcontractor Payment Information - Form for reporting the payments made to all MBE/WBE firms working on the project. This form is for paper bid projects only.
<https://connect.ncdot.gov/business/Turnpike/Documents/Form%20DBE-IS%20Subcontractor%20Payment%20Information.pdf>

RF-1 MBE/WBE Replacement Request Form - Form for replacing a committed MBE or WBE.
<https://connect.ncdot.gov/projects/construction/Construction%20Forms/DBE%20MBE%20WBE%20Replacement%20Form%20and%20Instructions.pdf>

SAF Subcontract Approval Form - Form required for approval to sublet the contract.
<https://connect.ncdot.gov/projects/construction/Construction%20Forms/SAF%20Form%20-%20Subcontract%20Approval%20Form%20Revised%2004-19.xlsm>

JC-1 Joint Check Notification Form - Form and procedures for joint check notification. The form acts as a written joint check agreement among the parties providing full and prompt disclosure of the expected use of joint checks.
<http://connect.ncdot.gov/projects/construction/Construction%20Forms/Joint%20Check%20Notification%20Form.pdf>

Letter of Intent - Form signed by the Contractor and the MBE/WBE subcontractor, manufacturer or regular dealer that affirms that a portion of said contract is going to be performed by the signed MBE/WBE for the estimated amount (based on quantities and unit prices) listed at the time of bid.
<http://connect.ncdot.gov/letting/LetCentral/Letter%20of%20Intent%20to%20Perform%20as%20a%20Subcontractor.pdf>

Listing of MBE and WBE Subcontractors Form - Form for entering MBE/WBE subcontractors on a project that will meet the Combined MBE/WBE goal. This form is for paper bids only.
[http://connect.ncdot.gov/municipalities/Bid%20Proposals%20for%20LGA%20Content/09%20MBE-WBE%20Subcontractors%20\(State\).docx](http://connect.ncdot.gov/municipalities/Bid%20Proposals%20for%20LGA%20Content/09%20MBE-WBE%20Subcontractors%20(State).docx)

Subcontractor Quote Comparison Sheet - Spreadsheet for showing all subcontractor quotes in the work areas where MBEs and WBEs quoted on the project. This sheet is submitted with good faith effort packages.
<http://connect.ncdot.gov/business/SmallBusiness/Documents/DBE%20Subcontractor%20Quote%20Comparison%20Example.xls>

DBE Regular Dealer/Distributor Affirmation Form – Form is used to make a preliminary counting determination for each DBE listed as a regular dealer or distributor to assess its eligibility for 60 or 40 percent credit, respectively of the cost of materials or supplies based on its demonstrated capacity and intent to perform as a regular dealer or distributor, as defined in section 49 CFR 26.55 under the contract at issue. A Contractor will submit the completed form with the Letter of Intent.
<https://connect.ncdot.gov/projects/construction/Construction%20Forms/DBE%20Regular%20Dealer-Distributor%20Affirmation%20Form%20-%20USDOT%202024.pdf>

Combined MBE/WBE Goal

There is NO MBE/WBE Goal for this project.

Directory of Transportation Firms (Directory)

Real-time information is available about firms doing business with the Department and firms that are certified through NCUCP in the Directory of Transportation Firms. Only firms identified in the Directory as MBE and WBE certified shall be used to meet the Combined MBE/WBE Goal. The Directory can be found at the following link.

<https://www.ebs.nc.gov/VendorDirectory/default.html>

The listing of an individual firm in the directory shall not be construed as an endorsement of the firm's capability to perform certain work.

Listing of MBE/WBE Subcontractors

At the time of bid, bidders shall submit all MBE and WBE participation that they anticipate to use during the life of the contract. Only those identified to meet the Combined MBE/WBE Goal will be considered committed, even though the listing shall include both committed MBE/WBE subcontractors and additional MBE/WBE subcontractors. Any additional MBE/WBE subcontractor participation above the goal will follow the banking guidelines found elsewhere in this provision. All other additional MBE/WBE subcontractor participation submitted at the time of bid will be used toward the Department's overall race-neutral goals. Only those firms with current MBE and WBE certification at the time of bid opening will be acceptable for listing in the bidder's submittal of MBE and WBE participation. The Contractor shall indicate the following required information:

(A) Electronic Bids

Bidders shall submit a listing of MBE and WBE participation in the appropriate section of the electronic submittal file.

- (1) Submit the names and addresses of MBE and WBE firms identified to participate in the contract. If the bidder uses the updated listing of MBE and WBE firms shown in the electronic submittal file, the bidder may use the dropdown menu to access the name and address of the firms.
- (2) Submit the contract line numbers of work to be performed by each MBE and WBE firm. When no figures or firms are entered, the bidder will be considered to have no MBE or WBE participation.
- (3) The bidder shall be responsible for ensuring that the MBE and WBE are certified at the time of bid by checking the Directory of Transportation Firms. If the firm is not certified at the time of the bid-letting, that MBE's or WBE's participation will not count towards achieving the Combined MBE/WBE goal.

(B) Paper Bids

- (1) *If the Combined MBE/WBE Goal is more than zero,*
 - (a) Bidders, at the time the bid proposal is submitted, shall submit a listing of MBE/WBE participation, including the names and addresses on *Listing of MBE and WBE Subcontractors* contained elsewhere in the contract documents in order for the bid to be considered responsive. Bidders shall indicate the total dollar value of the MBE and WBE participation for the contract.
 - (b) If bidders have no MBE or WBE participation, they shall indicate this on the *Listing of MBE and WBE Subcontractors* by entering the word “None” or the number “0.” This form shall be completed in its entirety. **Blank forms will not be deemed to represent zero participation.** Bids submitted that do not have MBE and WBE participation indicated on the appropriate form will not be read publicly during the opening of bids. The Department will not consider these bids for award and the proposal will be rejected.
 - (c) The bidder shall be responsible for ensuring that the MBE/WBE is certified at the time of bid by checking the Directory of Transportation Firms. If the firm is not certified at the time of the bid-letting, that MBE’s or WBE’s participation will not count towards achieving the Combined MBE/WBE Goal.
- (2) *If the Combined MBE/WBE Goal is zero,* entries on the *Listing of MBE and WBE Subcontractors* are not required for the zero goal, however any MBE or WBE participation that is achieved during the project shall be reported in accordance with requirements contained elsewhere in the special provision.

MBE or WBE Prime Contractor

When a certified MBE or WBE firm bids on a contract that contains a Combined MBE/WBE goal, the firm is responsible for meeting the goal or making good faith efforts to meet the goal, just like any other bidder. In most cases, a MBE or WBE bidder on a contract will meet the Combined MBE/WBE Goal by virtue of the work it performs on the contract with its own forces. However, all the work that is performed by the MBE or WBE bidder and any other similarly certified subcontractors will count toward the goal. The MBE or WBE bidder shall list itself along with any MBE or WBE subcontractors, if any, in order to receive credit toward the goal.

MBE/WBE prime contractors shall also follow Sections A and B listed under *Listing of MBE/WBE Subcontractor* just as a non-MBE/WBE bidder would.

Written Documentation – Letter of Intent

The bidder shall submit written documentation for each MBE/WBE that will be used to meet the Combined MBE/WBE Goal of the contract, indicating the bidder’s commitment to use the

MBE/WBE in the contract. This documentation shall be submitted on the Department's form titled *Letter of Intent*.

The documentation shall be received in the office of the State Contractor Utilization Engineer or at DBE@ncdot.gov no later than 10:00 a.m. of the sixth calendar day following opening of bids, unless the sixth day falls on an official state holiday. In that situation, it is due in the office of the State Contractor Utilization Engineer no later than 10:00 a.m. on the next official state business day.

If the bidder fails to submit the Letter of Intent from each committed MBE and WBE to be used toward the Combined MBE/WBE Goal, or if the form is incomplete (i.e. both signatures are not present), the MBE/WBE participation will not count toward meeting the Combined MBE/WBE Goal. If the lack of this participation drops the commitment below the Combined MBE/WBE Goal, the Contractor shall submit evidence of good faith efforts for the goal, completed in its entirety, to the State Contractor Utilization Engineer or DBE@ncdot.gov no later than 10:00 a.m. on the eighth calendar day following opening of bids, unless the eighth day falls on an official state holiday. In that situation, it is due in the office of the State Contractor Utilization Engineer no later than 10:00 a.m. on the next official state business day.

Banking MBE/WBE Credit

If the bid of the lowest responsive bidder exceeds \$500,000 and if the committed MBE/WBE participation submitted exceeds the algebraic sum of the Combined MBE /WBE Goal by \$1,000 or more, the excess will be placed on deposit by the Department for future use by the bidder. Separate accounts will be maintained for MBE and WBE participation and these may accumulate for a period not to exceed 24 months.

When the apparent lowest responsive bidder fails to submit sufficient participation by MBE and WBE firms to meet the advertised goal, as part of the good faith effort, the Department will consider allowing the bidder to withdraw funds to meet the Combined MBE/WBE Goal as long as there are adequate funds available from the bidder's MBE and WBE bank accounts.

Submission of Good Faith Effort

If the bidder fails to meet or exceed the Combined MBE/WBE Goal, the apparent lowest responsive bidder shall submit to the Department documentation of adequate good faith efforts made to reach that specific goal.

A hard copy and an electronic copy of this information shall be received in the office of the State Contractor Utilization Engineer or at DBE@ncdot.gov no later than 10:00 a.m. on the sixth calendar day following opening of bids unless the sixth day falls on an official state holiday. In that situation, it would be due in the office of the State Contractor Utilization Engineer no later than 10:00 a.m. on the next official state business day. If the Contractor cannot send the information electronically, then one complete set and 5 copies of this information shall be received under the same time constraints above.

Note: Where the information submitted includes repetitious solicitation letters, it will be acceptable to submit a representative letter along with a distribution list of the firms that were

solicited. Documentation of MBE/WBE quotations shall be a part of the good faith effort submittal. This documentation may include written subcontractor quotations, telephone log notations of verbal quotations, or other types of quotation documentation.

Consideration of Good Faith Effort for Projects with a Combined MBE/WBE Goal More Than Zero

Adequate good faith efforts mean that the bidder took all necessary and reasonable steps to achieve the goal which, by their scope, intensity, and appropriateness, could reasonably be expected to obtain sufficient MBE/WBE participation. Adequate good faith efforts also mean that the bidder actively and aggressively sought MBE/WBE participation. Mere *pro forma* efforts are not considered good faith efforts.

The Department will consider the quality, quantity, and intensity of the different kinds of efforts a bidder has made. Listed below are examples of the types of actions a bidder will take in making a good faith effort to meet the goals and are not intended to be exclusive or exhaustive, nor is it intended to be a mandatory checklist.

- (A) Soliciting through all reasonable and available means (e.g. attendance at pre-bid meetings, advertising, written notices, use of verifiable electronic means through the use of the NCDOT Directory of Transportation Firms) the interest of all certified MBEs/WBEs that are also prequalified subcontractors. The bidder must solicit this interest within at least 10 days prior to bid opening to allow the MBEs/WBEs to respond to the solicitation. Solicitation shall provide the opportunity to MBEs/WBEs within the Division and surrounding Divisions where the project is located. The bidder must determine with certainty if the MBEs/WBEs are interested by taking appropriate steps to follow up initial solicitations.
- (B) Selecting portions of the work to be performed by MBEs/WBEs in order to increase the likelihood that the Combined MBE/WBE Goal will be achieved.
 - (1) Where appropriate, break out contract work items into economically feasible units to facilitate MBE/WBE participation, even when the prime contractor might otherwise prefer to perform these work items with its own forces.
 - (2) Negotiate with subcontractors to assume part of the responsibility to meet the advertised goal when the work to be sublet includes potential for MBE/WBE participation (2nd and 3rd tier subcontractors).
- (C) Providing interested certified MBEs/WBEs that are also prequalified subcontractors with adequate information about the plans, specifications, and requirements of the contract in a timely manner to assist them in responding to a solicitation.
- (D)
 - (1) Negotiating in good faith with interested MBEs/WBEs. It is the bidder's responsibility to make a portion of the work available to MBE/WBE subcontractors and suppliers and to select those portions of the work or material needs consistent with the available MBE/WBE subcontractors and suppliers, so as to facilitate MBE/WBE participation. Evidence of such negotiation includes the

names, addresses, and telephone numbers of MBEs/WBEs that were considered; a description of the information provided regarding the plans and specifications for the work selected for subcontracting; and evidence as to why additional agreements could not be reached for MBEs/WBEs to perform the work.

- (2) A bidder using good business judgment would consider a number of factors in negotiating with subcontractors, including MBE/WBE subcontractors, and would take a firm's price and capabilities as well as the advertised goal into consideration. However, the fact that there may be some additional costs involved in finding and using MBEs/WBEs is not in itself sufficient reason for a bidder's failure to meet the contract goal, as long as such costs are reasonable. Also, the ability or desire of a prime contractor to perform the work of a contract with its own organization does not relieve the bidder of the responsibility to make good faith efforts. Bidding contractors are not, however, required to accept higher quotes from MBEs/WBEs if the price difference is excessive or unreasonable.
- (E) Not rejecting MBEs/WBEs as being unqualified without sound reasons based on a thorough investigation of their capabilities. The bidder's standing within its industry, membership in specific groups, organizations, or associates and political or social affiliations (for example, union vs. non-union employee status) are not legitimate causes for the rejection or non-solicitation of bids in the bidder's efforts to meet the project goal.
- (F) Making efforts to assist interested MBEs/WBEs in obtaining bonding, lines of credit, or insurance as required by the recipient or bidder.
- (G) Making efforts to assist interested MBEs/WBEs in obtaining necessary equipment, supplies, materials, or related assistance or services.
- (H) Effectively using the services of available minority/women community organizations; minority/women contractors' groups; Federal, State, and local minority/women business assistance offices; and other organizations as allowed on a case-by-case basis to provide assistance in the recruitment and placement of MBEs/WBEs. Contact within 7 days from the bid opening the Business Opportunity and Work Force Development Unit at BOWD@ncdot.gov to give notification of the bidder's inability to get MBE or WBE quotes.
- (I) Any other evidence that the bidder submits which shows that the bidder has made reasonable good faith efforts to meet the advertised goal.

In addition, the Department may take into account the following:

- (1) Whether the bidder's documentation reflects a clear and realistic plan for achieving the Combined MBE/WBE Goal.
- (2) The bidders' past performance in meeting the contract goal.

- (3) The performance of other bidders in meeting the advertised goal. For example, when the apparent successful bidder fails to meet the goal, but others meet it, you may reasonably raise the question of whether, with additional reasonable efforts the apparent successful bidder could have met the goal. If the apparent successful bidder fails to meet the advertised goal, but meets or exceeds the average MBE and WBE participation obtained by other bidders, the Department may view this, in conjunction with other factors, as evidence of the apparent successful bidder having made a good faith effort.

If the Department does not award the contract to the apparent lowest responsive bidder, the Department reserves the right to award the contract to the next lowest responsive bidder that can satisfy to the Department that the Combined MBE/WBE Goal can be met or that an adequate good faith effort has been made to meet the advertised goal.

Non-Good Faith Appeal

The State Prequalification Engineer will notify the Contractor verbally and in writing of non-good faith. A Contractor may appeal a determination of non-good faith made by the Goal Compliance Committee. If a Contractor wishes to appeal the determination made by the Committee, they shall provide written notification to the State Prequalification Engineer. The appeal shall be made within 2 business days of notification of the determination of non-good faith.

Counting MBE/WBE Participation Toward Meeting the Combined MBE/WBE Goal

(A) Participation

The total dollar value of the participation by a committed MBE/WBE will be counted toward the contract goal requirements. The total dollar value of participation by a committed MBE/WBE will be based upon the value of work performed by the MBE/WBE and the actual payments to MBE/WBE firms by the Contractor.

(B) Joint Checks

Prior notification of joint check use shall be required when counting MBE/WBE participation for services or purchases that involves the use of a joint check. Notification shall be through submission of Form JC-1 (*Joint Check Notification Form*) and the use of joint checks shall be in accordance with the Department's Joint Check Procedures.

(C) Subcontracts (Non-Trucking)

A MBE/WBE may enter into subcontracts. Work that a MBE subcontracts to another MBE firm may be counted toward the anticipated MBE participation. The same holds true for work that a WBE subcontracts to another WBE firm. Work that a MBE/WBE subcontracts to a non-MBE/WBE firm does not count toward the contract goal requirement. It should be noted that every effort shall be made by MBE and WBE contractors to subcontract to the same certification (i.e., MBEs to MBEs and WBEs to

WBEs), in order to fulfill the MBE or WBE participation breakdown. This, however, may not always be possible due to the limitation of firms in the area. If the MBE or WBE firm shows a good faith effort has been made to reach out to similarly certified firms and there is no interest or availability, and they can get assistance from other certified firms, the Engineer will not hold the prime responsible for meeting the individual MBE or WBE breakdown. If a MBE or WBE contractor or subcontractor subcontracts a significantly greater portion of the work of the contract than would be expected on the basis of standard industry practices, it shall be presumed that the MBE or WBE is not performing a commercially useful function.

(D) Joint Venture

When a MBE or WBE performs as a participant in a joint venture, the Contractor may count toward its contract goal requirement a portion of the total value of participation with the MBE or WBE in the joint venture, that portion of the total dollar value being a distinct clearly defined portion of work that the MBE or WBE performs with its forces.

(E) Manufacturer, Regular Dealer, Distributor

A Contractor may count toward its MBE/WBE requirement 40 percent of its expenditures for materials or supplies (including transportation costs) from a MBE/WBE distributor, 60 percent of its expenditures for materials or supplies (including transportation costs) from a MBE/WBE regular dealer and 100 percent of such expenditures obtained from a MBE/WBE manufacturer.

A Contractor may count toward its MBE/WBE requirement the following expenditures to MBE/WBE firms that are not manufacturers, regular dealers or distributors:

- (1) The fees or commissions charged by a MBE/WBE firm for providing a *bona fide* service, such as professional, technical, consultant, or managerial services, or for providing bonds or insurance specifically required for the performance of a DOT-assisted contract, provided the fees or commissions are determined to be reasonable and not excessive as compared with fees and commissions customarily allowed for similar services.
- (2) With respect to materials or supplies purchased from a MBE/WBE, which is neither a manufacturer, regular dealer, nor a distributor count the entire amount of fees or commissions charged that the Department deems to be reasonable, including transportation charges for the delivery of materials or supplies. Do not count any portion of the cost of the materials and supplies themselves.

A Contractor will submit a completed *DBE Regular Dealer/Distributor Affirmation Form* with the Letter of Intent to the State Contractor Utilization Engineer or DBE@ncdot.gov. The State Contractor Utilization Engineer will make a preliminary assessment as to whether a MBE/WBE supplier has the demonstrated capacity to perform a commercially useful function (CUF) on a contract-by-contract basis *prior* to its participation.

Commercially Useful Function**(A) MBE/WBE Utilization**

The Contractor may count toward its contract goal requirement only expenditures to MBEs and WBEs that perform a commercially useful function in the work of a contract. A MBE/WBE performs a commercially useful function when it is responsible for execution of the work of the contract and is carrying out its responsibilities by performing, managing, and supervising the work involved. To perform a commercially useful function, the MBE/WBE shall also be responsible with respect to materials and supplies used on the contract, for negotiating price, determining quality and quantity, ordering the material and installing (where applicable) and paying for the material itself. To determine whether a MBE/WBE is performing a commercially useful function, the Department will evaluate the amount of work subcontracted, industry practices, whether the amount the firm is to be paid under the contract is commensurate with the work it is performing and the MBE/WBE credit claimed for its performance of the work, and any other relevant factors. If it is determined that a MBE or WBE is not performing a Commercially Useful Function, the contractor may present evidence to rebut this presumption to the Department.

(B) MBE/WBE Utilization in Trucking

The following factors will be used to determine if a MBE or WBE trucking firm is performing a commercially useful function:

- (1) The MBE/WBE shall be responsible for the management and supervision of the entire trucking operation for which it is responsible on a particular contract, and there shall not be a contrived arrangement for the purpose of meeting the Combined MBE/WBE Goal.
- (2) The MBE/WBE shall itself own and operate at least one fully licensed, insured, and operational truck used on the contract.
- (3) The MBE/WBE receives credit for the total value of the transportation services it provides on the contract using trucks it owns, insures, and operates using drivers it employs.
- (4) The MBE may subcontract the work to another MBE firm, including an owner-operator who is certified as a MBE. The same holds true that a WBE may subcontract the work to another WBE firm, including an owner-operator who is certified as a WBE. When this occurs, the MBE or WBE who subcontracts work receives credit for the total value of the transportation services the subcontracted MBE or WBE provides on the contract. It should be noted that every effort shall be made by MBE and WBE contractors to subcontract to the same certification (i.e., MBEs to MBEs and WBEs to WBEs), in order to fulfill the participation breakdown. This, however, may not always be possible due to the limitation of firms in the area. If the MBE or WBE firm shows a good faith

effort has been made to reach out to similarly certified transportation service providers and there is no interest or availability, and they can get assistance from other certified providers, the Engineer will not hold the prime responsible for meeting the individual MBE or WBE participation breakdown.

- (5) The MBE/WBE may also subcontract the work to a non-MBE/WBE firm, including from an owner-operator. The MBE/WBE who subcontracts the work to a non-MBE/WBE is entitled to credit for the total value of transportation services provided by the non-MBE/WBE subcontractor not to exceed the value of transportation services provided by MBE/WBE-owned trucks on the contract. Additional participation by non-MBE/WBE subcontractors receives credit only for the fee or commission it receives as a result of the subcontract arrangement. The value of services performed under subcontract agreements between the MBE/WBE and the Contractor will not count towards the MBE/WBE contract requirement.
- (6) A MBE/WBE may lease truck(s) from an established equipment leasing business open to the general public. The lease must indicate that the MBE/WBE has exclusive use of and control over the truck. This requirement does not preclude the leased truck from working for others during the term of the lease with the consent of the MBE/WBE, so long as the lease gives the MBE/WBE absolute priority for use of the leased truck. This type of lease may count toward the MBE/WBE's credit as long as the driver is under the MBE/WBE's payroll.
- (7) Subcontracted/leased trucks shall display clearly on the dashboard the name of the MBE/WBE that they are subcontracted/leased to and their own company name if it is not identified on the truck itself. Magnetic door signs are not permitted.

MBE/WBE Replacement

When a Contractor has relied on a commitment to a MBE or WBE subcontractor (or an approved substitute MBE or WBE subcontractor) to meet all or part of a contract goal requirement, the contractor shall not terminate the MBE/WBE subcontractor or any portion of its work for convenience. This includes, but is not limited to, instances in which the Contractor seeks to perform the work of the terminated subcontractor with another MBE/WBE subcontractor, a non-MBE/WBE subcontractor, or with the Contractor's own forces or those of an affiliate.

The Contractor must give notice in writing both by certified mail and email to the MBE/WBE subcontractor, with a copy to the Engineer of its intent to request to terminate a MBE/WBE subcontractor or any portion of its work, and the reason for the request. The Contractor must give the MBE/WBE subcontractor five (5) business days to respond to the Contractor's Notice of Intent to Request Termination and/or Substitution. If the MBE/WBE subcontractor objects to the intended termination/substitution, the MBE/WBE, within five (5) business days must advise the Contractor and the Department of the reasons why the action should not be approved. The five-day notice period shall begin on the next business day after written notice is provided to the MBE/WBE subcontractor.

A committed MBE/WBE subcontractor may only be terminated or any portion of its work after receiving the Department's written approval based upon a finding of good cause for the proposed termination and/or substitution. Good cause does not exist if the Contractor seeks to terminate a MBE/WBE or any portion of its work that it relied upon to obtain the contract so that the Contractor can self-perform the work for which the MBE/WBE was engaged, or so that the Contractor can substitute another MBE/WBE or non- MBE/WBE contractor after contract award. For purposes of this section, good cause shall include the following circumstances:

- (a) The listed MBE/WBE subcontractor fails or refuses to execute a written contract;
- (b) The listed MBE/WBE subcontractor fails or refuses to perform the work of its subcontract in a way consistent with normal industry standards. Provided, however, that good cause does not exist if the failure or refusal of the MBE/WBE subcontractor to perform its work on the subcontract results from the bad faith or discriminatory action of the prime contractor;
- (c) The listed MBE/WBE subcontractor fails or refuses to meet the prime contractor's reasonable, nondiscriminatory bond requirements;
- (d) The listed MBE/WBE subcontractor becomes bankrupt, insolvent, or exhibits credit unworthiness;
- (e) The listed MBE/WBE subcontractor is ineligible to work on public works projects because of suspension and debarment proceedings pursuant to 2 CFR parts 180, 215 and 1200 or applicable State law;
- (f) The listed MBE/WBE subcontractor is not a responsible contractor;
- (g) The listed MBE/WBE voluntarily withdraws from the project and provides written notice of withdrawal;
- (h) The listed MBE/WBE is ineligible to receive MBE/WBE credit for the type of work required;
- (i) A MBE/WBE owner dies or becomes disabled with the result that the listed MBE/WBE contractor is unable to complete its work on the contract; and
- (j) Other documented good cause that compels the termination of the MBE/WBE subcontractor.

The Contractor shall comply with the following for replacement of a committed MBE/WBE:

(A) Performance Related Replacement

When a committed MBE/WBE is terminated for good cause as stated above, an additional MBE/WBE that was submitted at the time of bid may be used to fulfill the MBE/WBE commitment to meet the Combined MBE/WBE Goal. A good faith effort will only be required for removing a committed MBE/WBE if there were no additional MBE/WBEs submitted at the time of bid to cover the same amount of work as the MBE/WBE that was terminated.

If a replacement MBE/WBE is not found that can perform at least the same amount of work as the terminated MBE/WBE, the Contractor shall submit a good faith effort documenting the steps taken. Such documentation shall include, but not be limited to, the following:

- (1) Copies of written notification to MBE/WBEs that their interest is solicited in contracting the work defaulted by the previous MBE/WBE or in subcontracting other items of work in the contract.
 - (2) Efforts to negotiate with MBE/WBEs for specific subbids including, at a minimum:
 - (a) The names, addresses, and telephone numbers of MBE/WBEs who were contacted.
 - (b) A description of the information provided to MBE/WBEs regarding the plans and specifications for portions of the work to be performed.
 - (3) A list of reasons why MBE/WBE quotes were not accepted.
 - (4) Efforts made to assist the MBE/WBEs contacted, if needed, in obtaining bonding or insurance required by the Contractor.
- (B) Decertification Replacement
- (1) When a committed MBE/WBE is decertified by the Department after the SAF (*Subcontract Approval Form*) has been received by the Department, the Department will not require the Contractor to solicit replacement MBE/WBE participation equal to the remaining work to be performed by the decertified firm. The participation equal to the remaining work performed by the decertified firm will count toward the contract goal requirement but not the overall goal.
 - (i) If the MBE/WBE's ineligibility is caused solely by its having exceeded the size standard during the performance of the contract. The Department may continue to count participation equal to the remaining work performed by the decertified firm which will count toward the contract goal requirement and overall goal.
 - (ii) If the MBE/WBE's ineligibility is caused solely by its acquisition by or merger with a non- MBE/WBE during the performance of the contract. The Department may not continue to count the portion of the decertified firm's performance on the contract remaining toward either the contract goal or the overall goal, even if the Contractor has executed a subcontract with the firm or the Department has executed a prime contract with the MBE/WBE that was later decertified.
 - (2) When a committed MBE/WBE is decertified prior to the Department receiving the SAF (*Subcontract Approval Form*) for the named MBE/WBE firm, the

Contractor shall take all necessary and reasonable steps to replace the MBE/WBE subcontractor with another MBE/WBE subcontractor to perform at least the same amount of work to meet the Combined MBE/WBE goal requirement. If a MBE/WBE firm is not found to do the same amount of work, a good faith effort must be submitted to NCDOT (see A herein for required documentation).

All requests for replacement of a committed MBE/WBE firm shall be submitted to the Engineer for approval on Form RF-1 (*DBE Replacement Request*). If the Contractor fails to follow this procedure, the Contractor may be disqualified from further bidding for a period of up to 6 months.

Changes in the Work

When the Engineer makes changes that result in the reduction or elimination of work to be performed by a committed MBE/WBE, the Contractor will not be required to seek additional participation. When the Engineer makes changes that result in additional work to be performed by a MBE/WBE based upon the Contractor's commitment, the MBE/WBE shall participate in additional work to the same extent as the MBE/WBE participated in the original contract work.

When the Engineer makes changes that result in extra work, which has more than a minimal impact on the contract amount, the Contractor shall seek additional participation by MBEs/WBEs unless otherwise approved by the Engineer.

When the Engineer makes changes that result in an alteration of plans or details of construction, and a portion or all of the work had been expected to be performed by a committed MBE/WBE, the Contractor shall seek participation by MBEs/WBEs unless otherwise approved by the Engineer.

When the Contractor requests changes in the work that result in the reduction or elimination of work that the Contractor committed to be performed by a MBE/WBE, the Contractor shall seek additional participation by MBEs/WBEs equal to the reduced MBE/WBE participation caused by the changes.

Reports and Documentation

A SAF (*Subcontract Approval Form*) shall be submitted for all work which is to be performed by a MBE/WBE subcontractor. The Department reserves the right to require copies of actual subcontract agreements involving MBE/WBE subcontractors.

When using transportation services to meet the contract commitment, the Contractor shall submit a proposed trucking plan in addition to the SAF. The plan shall be submitted prior to beginning construction on the project. The plan shall include the names of all trucking firms proposed for use, their certification type(s), the number of trucks owned by the firm, as well as the individual truck identification numbers, and the line item(s) being performed.

Within 30 calendar days of entering into an agreement with a MBE/WBE for materials, supplies or services, not otherwise documented by the SAF as specified above, the Contractor shall

furnish the Engineer a copy of the agreement. The documentation shall also indicate the percentage (60% or 100%) of expenditures claimed for MBE/WBE credit.

Reporting Minority and Women Business Enterprise Participation

The Contractor shall provide the Engineer with an accounting of payments made to all MBE/WBE firms, including material suppliers and contractors at all levels (prime, subcontractor, or second tier subcontractor). This accounting shall be furnished to the Engineer for any given month by the end of the following month. Failure to submit this information accordingly may result in the following action:

- (A) Withholding of money due in the next partial pay estimate; or
- (B) Removal of an approved contractor from the prequalified bidders' list or the removal of other entities from the approved subcontractors list.

While each contractor (prime, subcontractor, 2nd tier subcontractor) is responsible for accurate accounting of payments to MBEs/WBEs, it shall be the prime contractor's responsibility to report all monthly and final payment information in the correct reporting manner.

Failure on the part of the Contractor to submit the required information in the time frame specified may result in the disqualification of that contractor and any affiliate companies from further bidding until the required information is submitted.

Failure on the part of any subcontractor to submit the required information in the time frame specified may result in the disqualification of that contractor and any affiliate companies from being approved for work on future DOT projects until the required information is submitted.

Contractors reporting transportation services provided by non-MBE/WBE lessees shall evaluate the value of services provided during the month of the reporting period only.

At any time, the Engineer can request written verification of subcontractor payments.

The Contractor shall report the accounting of payments through the Department's Payment Tracking System.

Failure to Meet Contract Requirements

Failure to meet contract requirements in accordance with Subarticle 102-15(J) of the *Standard Specifications* may be cause to disqualify the Contractor.

RESTRICTIONS ON ITS EQUIPMENT AND SERVICES:

(11-17-20)

SP01 G090

All telecommunications, video or other ITS equipment or services installed or utilized on this project must be in conformance with UNIFORM ADMINISTRATIVE REQUIREMENTS, COST PRINCIPLES, AND AUDIT REQUIREMENTS FOR FEDERAL AWARDS **2 CFR, § 200.216 Prohibition on certain telecommunications and video surveillance services or equipment.**

USE OF UNMANNED AIRCRAFT SYSTEM (UAS):

(8-20-19)(Rev. 3-17-26)

SP1 G092

The Contractor shall adhere to all Federal, State and Local regulations and guidelines for the use of Unmanned Aircraft Systems (UAS). This includes but is not limited to US 14 CFR Part 107, NC GS 15A-300, American Security Drone Act of 2023 (ASDA), Office of Management and Budget (OMB) Memorandum M-26-02, all FAA rules, regulations and policies and all NCDOT UAS Policies. The required operator certifications include possessing a current Federal Aviation Administration (FAA) Remote Pilot Certificate, as well as operating a UAS registered with the FAA.

All UAS operations shall be approved by the Engineer prior to beginning the operations.

All contractors or subcontractors operating UAS shall have UAS specific general liability insurance to cover all operations under this contract.

The use of UAS is at the Contractor's discretion. No measurement or payment will be made for the use of UAS. In the event that the Department directs the Contractor to utilize UAS, payment will be in accordance with Article 104-7 Extra Work.

EQUIPMENT IDLING GUIDELINES:

(1-19-21)

107

SP1 G096

Exercise reduced fuel consumption and reduced equipment emissions during the construction of all work associated with this contract. Employees engaged in the construction of this project should turn off vehicles when stopped for more than thirty (30) minutes and off-highway equipment should idle no longer than fifteen (15) consecutive minutes.

These guidelines for turning off vehicles and equipment when idling do not apply to:

1. Idling when queuing.
2. Idling to verify the vehicle is in safe operating condition.
3. Idling for testing, servicing, repairing or diagnostic purposes.
4. Idling necessary to accomplish work for which the vehicle was designed (such as operating a crane, mixing concrete, etc.).
5. Idling required to bring the machine system to operating temperature.
6. Emergency vehicles, utility company, construction, and maintenance vehicles where the engines must run to perform needed work.
7. Idling to ensure safe operation of the vehicle.

8. Idling when the propulsion engine is providing auxiliary power for other than heating or air conditioning. (such as hydraulic systems for pavers)
9. When specific traffic, safety, or emergency situations arise.
10. If the ambient temperature is less than 32 degrees Fahrenheit. Limited idling to provide for the safety of vehicle occupants (e.g. to run the heater).
11. If the ambient temperature is greater than 90 degrees Fahrenheit. Limited idling to provide for the safety of vehicle occupants of off-highway equipment (e.g. to run the air conditioning) no more than 30 minutes.
12. Diesel powered vehicles may idle for up to 30 minutes to minimize restart problems.

Any vehicle, truck, or equipment in which the primary source of fuel is natural gas or electricity is exempt from the idling limitations set forth in this special provision.

SUBSURFACE INFORMATION:

(7-1-95)

450

SPI G112 C

Subsurface information is available on the roadway and structure portions of this project.

PORTABLE CONCRETE BARRIER - (Partial Payments for Materials):

(7-1-95)(Rev. 1-16-24)

1170-4

SPI G121

When so authorized by the Engineer, partial materials payments will be made up to 95 percent of the delivered cost of portable concrete barrier, provided that these materials have been delivered on the project and stored in an acceptable manner, and further provided the documents listed in Subarticle 109-5(C) of the *Standard Specifications* have been furnished to the Engineer.

The provisions of Subarticle 109-5(B) of the *Standard Specifications* will apply to the portable concrete barrier.

REMOVABLE PAVEMENT MARKINGS - (Partial Payments for Materials):

(7-1-95)(Rev. 1-16-24)

1205-10

SPI G124

When so authorized by the Engineer, partial materials payments will be made up to 95 percent of the delivered cost of pavement marking tape, provided that these materials have been delivered on or in the vicinity of the project, stored in an acceptable manner, not to exceed the shelf life recommended by the manufacturer, and further provided the documents listed in Subarticle 109-5(C) of the *Standard Specifications* have been furnished to the Engineer.

The Contractor shall be responsible for the material and the satisfactory performance of the material when used in the work.

The provisions of Article 109-6 of the *Standard Specifications* will not apply to removable pavement marking materials.

MAINTENANCE OF THE PROJECT:

(11-20-07)(Rev. 1-16-24)

104-10

SPI G125

Revise the *Standard Specifications* as follows:

Page 1-35, Article 104-10 Maintenance of the Project, line 3, add the following after the first sentence of the first paragraph:

All guardrail/guiderail within the project limits shall be included in this maintenance.

Page 1-35, Article 104-10 MAINTENANCE OF THE PROJECT, line 8, add the following as the last sentence of the first paragraph:

The Contractor shall perform weekly inspections of guardrail and guiderail and shall report damages to the Engineer on the same day of the weekly inspection. *Where damaged guardrail or guiderail is repaired or replaced as a result of maintaining the project in accordance with this article, such repair or replacement shall be performed within 7 consecutive calendar days of such inspection report.*

Page 1-35, Article 104-10 MAINTENANCE OF THE PROJECT, lines 20-22, replace the last sentence of the last paragraph with the following:

The Contractor will not be directly compensated for any maintenance operations necessary, except for maintenance of guardrail/guiderail, as this work will be considered incidental to the work covered by the various contract items. The provisions of Article 104-7, Extra Work, and Article 104-8, Compensation and Record Keeping will apply to authorized maintenance of guardrail/guiderail. Performance of weekly inspections of guardrail/guiderail, and the damage reports required as described above, will be considered to be an incidental part of the work being paid for by the various contract items.

TWELVE MONTH GUARANTEE:

(7-15-03)

108

SPI G145

- (A) The Contractor shall guarantee materials and workmanship against latent and patent defects arising from faulty materials, faulty workmanship or negligence for a period of twelve months following the date of final acceptance of the work for maintenance and shall replace such defective materials and workmanship without cost to the Department. The Contractor will not be responsible for damage due to faulty design, normal wear and tear, for negligence on the part of the Department, and/or for use in excess of the design.
- (B) Where items of equipment or material carry a manufacturer's guarantee for any period in excess of twelve months, then the manufacturer's guarantee shall apply for that particular piece of equipment or material. The Department's first remedy shall be through the manufacturer although the Contractor is responsible for invoking the warranted repair work with the manufacturer. The Contractor's responsibility shall be limited to the term of the manufacturer's guarantee. NCDOT would be afforded the same warranty as provided by the Manufacturer.

This guarantee provision shall be invoked only for major components of work in which the Contractor would be wholly responsible for under the terms of the contract. Examples would include pavement structures, bridge components, and sign structures. This provision will not be used as a mechanism to force the Contractor to return to the project to make repairs or perform additional work that the Department would normally compensate the Contractor for. In addition, routine maintenance activities (i.e. mowing grass, debris removal, ruts in earth shoulders,) are not parts of this guarantee.

Appropriate provisions of the payment and/or performance bonds shall cover this guarantee for the project.

To ensure uniform application statewide the Division Engineer will forward details regarding the circumstances surrounding any proposed guarantee repairs to the Chief Engineer for review and approval prior to the work being performed.

OUTSOURCING OUTSIDE THE USA:

(9-21-04) (Rev. 5-16-06)

SP1 G150

All work on consultant contracts, services contracts, and construction contracts shall be performed in the United States of America. No work shall be outsourced outside of the United States of America.

Outsourcing for the purpose of this provision is defined as the practice of subcontracting labor, work, services, staffing, or personnel to entities located outside of the United States.

The North Carolina Secretary of Transportation shall approve exceptions to this provision in writing.

EROSION AND SEDIMENT CONTROL/STORMWATER CERTIFICATION:

(1-16-07) (Rev. 10-15-24)

105-16, 225-2, 16

SP1 G180

General

Schedule and conduct construction activities in a manner that will minimize soil erosion and the resulting sedimentation and turbidity of surface waters. Comply with the requirements herein regardless of whether or not a National Pollution discharge Elimination System (NPDES) permit for the work is required.

Establish a chain of responsibility for operations and subcontractors' operations to ensure that the *Erosion and Sediment Control/Stormwater Pollution Prevention Plan* is implemented and maintained over the life of the contract.

- (A) *Certified Supervisor* - Provide a certified Erosion and Sediment Control/Stormwater Supervisor to manage the Contractor and subcontractor operations, insure compliance with Federal, State and Local ordinances and regulations, and manage the Quality Control Program.

- (B) *Certified Foreman* - Provide a certified, trained foreman for each construction operation that increases the potential for soil erosion or the possible sedimentation and turbidity of surface waters.
- (C) *Certified Installer* - Provide a certified installer to install or direct the installation for erosion or sediment/stormwater control practices.
- (D) *Certified Designer* - Provide a certified designer for the design of the erosion and sediment control/stormwater component of reclamation plans and, if applicable, for the design of the project erosion and sediment control/stormwater plan.

Roles and Responsibilities

- (A) *Certified Erosion and Sediment Control/Stormwater Supervisor* - The Certified Supervisor shall be Level II and responsible for ensuring the erosion and sediment control/stormwater plan is adequately implemented and maintained on the project and for conducting the quality control program. The Certified Supervisor shall be on the project within 24 hours notice from initial exposure of an erodible surface to the project's final acceptance. Perform the following duties:
 - (1) *Manage Operations* - Coordinate and schedule the work of subcontractors so that erosion and sediment control/stormwater measures are fully executed for each operation and in a timely manner over the duration of the contract.
 - (a) Oversee the work of subcontractors so that appropriate erosion and sediment control/stormwater preventive measures are conformed to at each stage of the work.
 - (b) Prepare the required National Pollutant Discharge Elimination System (NPDES) Inspection Record and submit to the Engineer.
 - (c) Attend all weekly or monthly construction meetings to discuss the findings of the NPDES inspection and other related issues.
 - (d) Implement the erosion and sediment control/stormwater site plans requested.
 - (e) Provide any needed erosion and sediment control/stormwater practices for the Contractor's temporary work not shown on the plans, such as, but not limited to work platforms, temporary construction, pumping operations, plant and storage yards, and cofferdams.
 - (f) Acquire applicable permits and comply with requirements for borrow pits, dewatering, and any temporary work conducted by the Contractor in jurisdictional areas.
 - (g) Conduct all erosion and sediment control/stormwater work in a timely and workmanlike manner.
 - (h) Fully perform and install erosion and sediment control/stormwater work prior to any suspension of the work.
 - (i) Coordinate with Department, Federal, State and Local Regulatory agencies on resolution of erosion and sediment control/stormwater issues due to the Contractor's operations.

- (j) Ensure that proper cleanup occurs from vehicle tracking on paved surfaces or any location where sediment leaves the Right-of-Way.
 - (k) Have available a set of erosion and sediment control/stormwater plans that are initialed and include the installation date of Best Management Practices. These practices shall include temporary and permanent groundcover and be properly updated to reflect necessary plan and field changes for use and review by Department personnel as well as regulatory agencies.
- (2) Requirements set forth under the NPDES Permit - The Department's NPDES Stormwater permit (NCS000250) outlines certain objectives and management measures pertaining to construction activities. The permit references *NCG010000, General Permit to Discharge Stormwater* under the NPDES, and states that the Department shall incorporate the applicable requirements into its delegated Erosion and Sediment Control Program for construction activities disturbing one or more acres of land. The Department further incorporates these requirements on all contracted bridge and culvert work at jurisdictional waters, regardless of size. Some of the requirements are, but are not limited to:
- (a) Control project site waste to prevent contamination of surface or ground waters of the state, i.e. from equipment operation/maintenance, construction materials, concrete washout, chemicals, litter, fuels, lubricants, coolants, hydraulic fluids, any other petroleum products, and sanitary waste.
 - (b) Inspect erosion and sediment control/stormwater devices and stormwater discharge outfalls at least once every 7 calendar days and within 24 hours after a rainfall event equal to or greater than 1.0 inch that occurs within a 24 hour period. Additional monitoring may be required at the discretion of Division of Water Resources personnel if the receiving stream is 303(d) listed for turbidity and the project has had documented problems managing turbidity.
 - (c) Maintain an onsite rain gauge or use the Department's Multi-Sensor Precipitation Estimate website to maintain a daily record of rainfall amounts and dates.
 - (d) Maintain erosion and sediment control/stormwater inspection records for review by Department and Regulatory personnel upon request.
 - (e) Implement approved reclamation plans on all borrow pits, waste sites and staging areas.
 - (f) Maintain a log of turbidity test results as outlined in the Department's Procedure for Monitoring Borrow Pit Discharge.
 - (g) Provide secondary containment for bulk storage of liquid materials.
 - (h) Provide training for employees concerning general erosion and sediment control/stormwater awareness, the Department's NPDES Stormwater Permit NCS000250 requirements, and the applicable requirements of the *General Permit, NCG010000*.
 - (i) Report violations of the NPDES permit to the Engineer immediately who will notify the Division of Water Quality Regional Office within 24 hours of becoming aware of the violation.

- (3) Quality Control Program - Maintain a quality control program to control erosion, prevent sedimentation and follow provisions/conditions of permits. The quality control program shall:
- (a) Follow permit requirements related to the Contractor and subcontractors' construction activities.
 - (b) Ensure that all operators and subcontractors on site have the proper erosion and sediment control/stormwater certification.
 - (c) Notify the Engineer when the required certified erosion and sediment control/stormwater personnel are not available on the job site when needed.
 - (d) Conduct the inspections required by the NPDES permit.
 - (e) Take corrective actions in the proper timeframe as required by the NPDES permit for problem areas identified during the NPDES inspections.
 - (f) Incorporate erosion control into the work in a timely manner and stabilize disturbed areas with mulch/seed or vegetative cover on a section-by-section basis.
 - (g) Use flocculants approved by state regulatory authorities where appropriate and where required for turbidity and sedimentation reduction.
 - (h) Ensure proper installation and maintenance of temporary erosion and sediment control devices.
 - (i) Remove temporary erosion or sediment control devices when they are no longer necessary as agreed upon by the Engineer.
 - (j) The Contractor's quality control and inspection procedures shall be subject to review by the Engineer. Maintain NPDES inspection records and make records available at all times for verification by the Engineer.
- (B) *Certified Foreman* - At least one Certified Foreman shall be onsite for each type of work listed herein during the respective construction activities to control erosion, prevent sedimentation and follow permit provisions:
- (1) Foreman in charge of grading activities
 - (2) Foreman in charge of bridge or culvert construction over jurisdictional areas
 - (3) Foreman in charge of utility activities

The Contractor may request to use the same person as the Level II Supervisor and Level II Foreman. This person shall be onsite whenever construction activities as described above are taking place. This request shall be approved by the Engineer prior to work beginning.

The Contractor may request to name a single Level II Foreman to oversee multiple construction activities on small bridge or culvert replacement projects. This request shall be approved by the Engineer prior to work beginning.

- (C) *Certified Installers* - Provide at least one onsite, Level I Certified Installer for each of the following erosion and sediment control/stormwater crew:

- (1) Seeding and Mulching
- (2) Temporary Seeding
- (3) Temporary Mulching
- (4) Sodding
- (5) Silt fence or other perimeter erosion/sediment control device installations
- (6) Erosion control blanket installation
- (7) Hydraulic tackifier installation
- (8) Turbidity curtain installation
- (9) Rock ditch check/sediment dam installation
- (10) Ditch liner/matting installation
- (11) Inlet protection
- (12) Riprap placement
- (13) Stormwater BMP installations (such as but not limited to level spreaders, retention/detention devices)
- (14) Pipe installations within jurisdictional areas

If a Level I *Certified Installer* is not onsite, the Contractor may substitute a Level II Foreman for a Level I Installer, provided the Level II Foreman is not tasked to another crew requiring Level II Foreman oversight.

- (D) *Certified Designer* - Include the certification number of the Level III Certified Designer on the erosion and sediment control/stormwater component of all reclamation plans and if applicable, the certification number of the Level III Certified Designer on the design of the project erosion and sediment control/stormwater plan.

Preconstruction Meeting

Furnish the names of the *Certified Erosion and Sediment Control/Stormwater Supervisor*, *Certified Foremen*, *Certified Installers* and *Certified Designer* and notify the Engineer of changes in certified personnel over the life of the contract within 2 days of change.

Ethical Responsibility

Any company performing work for the North Carolina Department of Transportation has the ethical responsibility to fully disclose any reprimand or dismissal of an employee resulting from improper testing or falsification of records.

Revocation or Suspension of Certification

Upon recommendation of the Chief Engineer to the certification entity, certification for *Supervisor*, *Certified Foremen*, *Certified Installers* and *Certified Designer* may be revoked or suspended with the issuance of an *Immediate Corrective Action (ICA)*, *Notice of Violation (NOV)*, or *Cease and Desist Order* for erosion and sediment control/stormwater related issues.

The Chief Engineer may recommend suspension or permanent revocation of certification due to the following:

- (A) Failure to adequately perform the duties as defined within this certification provision.
- (B) Issuance of an ICA, NOV, or Cease and Desist Order.
- (C) Failure to fully perform environmental commitments as detailed within the permit conditions and specifications.
- (D) Demonstration of erroneous documentation or reporting techniques.
- (E) Cheating or copying another candidate's work on an examination.
- (F) Intentional falsification of records.
- (G) Directing a subordinate under direct or indirect supervision to perform any of the above actions.
- (H) Dismissal from a company for any of the above reasons.
- (I) Suspension or revocation of one's certification by another entity.

Suspension or revocation of a certification will be sent by certified mail to the certificant and the Corporate Head of the company that employs the certificant.

A certificant has the right to appeal any adverse action which results in suspension or permanent revocation of certification by responding, in writing, to the Chief Engineer within 10 calendar days after receiving notice of the proposed adverse action.

Chief Engineer
1536 Mail Service Center
Raleigh, NC 27699-1536

Failure to appeal within 10 calendar days will result in the proposed adverse action becoming effective on the date specified on the certified notice. Failure to appeal within the time specified will result in a waiver of all future appeal rights regarding the adverse action taken. The certificant will not be allowed to perform duties associated with the certification during the appeal process.

The Chief Engineer will hear the appeal and make a decision within 7 days of hearing the appeal. Decision of the Chief Engineer will be final and will be made in writing to the certificant.

If a certification is temporarily suspended, the certificant shall pass any applicable written examination and any proficiency examination, at the conclusion of the specified suspension period, prior to having the certification reinstated.

Measurement and Payment

All work described within this provision and the role of Certified Erosion and Sediment Control/Stormwater Supervisor, Certified Foremen, Certified Installers and Certified Designer will be incidental to the project for which no direct compensation will be made.

PROCEDURE FOR MONITORING BORROW PIT DISCHARGE:

(2-20-07) (Rev. 1-16-24)

105-16, 230, 801

SPI G181

Water discharge from borrow pit sites shall not cause surface waters to exceed 50 NTUs (nephelometric turbidity unit) in streams not designated as trout waters and 10 NTUs in streams, lakes or reservoirs designated as trout waters. For lakes and reservoirs not designated as trout waters, the turbidity shall not exceed 25 NTUs. If the turbidity exceeds these levels due to natural background conditions, the existing turbidity level shall not be increased.

If during any operating day, the downstream water quality exceeds the standard, the Contractor shall do all of the following:

- (A) Either cease discharge or modify the discharge volume or turbidity levels to bring the downstream turbidity levels into compliance, or
- (B) Evaluate the upstream conditions to determine if the exceedance of the standard is due to natural background conditions. If the background turbidity measurements exceed the standard, operation of the pit and discharge can continue as long as the stream turbidity levels are not increased due to the discharge.
- (C) Measure and record the turbidity test results (time, date and sampler) at all defined sampling locations 30 minutes after startup and at a minimum, one additional sampling of all sampling locations during that 24-hour period in which the borrow pit is discharging.
- (D) Notify DWQ within 24 hours of any stream turbidity standard exceedances that are not brought into compliance.

During the Environmental Assessment required by Article 230-4 of the *Standard Specifications*, the Contractor shall define the point at which the discharge enters into the State's surface waters and the appropriate sampling locations. Sampling locations shall include points upstream and downstream from the point at which the discharge enters these waters. Upstream sampling location shall be located so that it is not influenced by backwater conditions and represents natural background conditions. Downstream sampling location shall be located at the point where complete mixing of the discharge and receiving water has occurred.

The discharge shall be closely monitored when water from the dewatering activities is introduced into jurisdictional wetlands. Any time visible sedimentation (deposition of sediment) on the wetland surface is observed, the dewatering activity will be suspended until turbidity levels in the stilling basin can be reduced to a level where sediment deposition does not occur. Staining of wetland surfaces from suspended clay particles, occurring after evaporation or infiltration, does not constitute sedimentation. No activities shall occur in wetlands that adversely affect the functioning of a wetland. Visible sedimentation will be considered an indication of possible adverse impacts on wetland use.

The Engineer will perform independent turbidity tests on a random basis. These results will be maintained in a log within the project records. Records will include, at a minimum, turbidity test results, time, date and name of sampler. Should the Department's test results exceed those of the Contractor's test results, an immediate test shall be performed jointly with the results superseding the previous test results of both the Department and the Contractor.

The Contractor shall use the *NCDOT Turbidity Reduction Options for Borrow Pits Matrix*, available at <https://connect.ncdot.gov/resources/roadside/FieldOperationsDocuments/TurbidityReductionOptionSheet.pdf> to plan, design, construct, and maintain BMPs to address water quality standards. Tier I Methods include stilling basins which are standard compensatory BMPs. Other Tier I methods are noncompensatory and shall be used when needed to meet the stream turbidity standards. Tier II Methods are also noncompensatory and are options that may be needed for protection of rare or unique resources or where special environmental conditions exist at the site which have led to additional requirements being placed in the DWQ's 401 Certifications and approval letters, Isolated Wetland Permits, Riparian Buffer Authorization or a DOT Reclamation Plan's Environmental Assessment for the specific site. Should the Contractor exhaust all Tier I Methods on a site exclusive of rare or unique resources or special environmental conditions, Tier II Methods may be required by regulators on a case by case basis per supplemental agreement.

The Contractor may use cation exchange capacity (CEC) values from proposed site borings to plan and develop the bid for the project. CEC values exceeding 15 milliequivalents per 100 grams of soil may indicate a high potential for turbidity and should be avoided when dewatering into surface water is proposed.

No additional compensation for monitoring borrow pit discharge will be paid.

NOTES TO CONTRACTOR:

If dead bats are observed during clearing, demolition, or any construction related activities, the contractor shall immediately notify the Engineer, who will then inform the Division Environmental Officer (DEO). The DEO will collect and preserve the bats for identification. If the DEO suspects dead bats of being NLEB or TCB, such bats will be placed in a freezer until coordination can be made with the USFWS Raleigh Field Office to arrange transfer.

The existing bridge, including the abandoned bridge abutment in the Southwest quadrant, temporary work bridges, as well as any remnant and/or structures, shall be removed in their entirety within 90 days after they are no longer needed and disposed of and/or recycled at an approved high ground site and as directed by the Engineer.

*The contractor shall be made aware the N.C. Department of Cultural and Natural Resources has identified a potential for cultural resources, such as sunken vessels, to be inadvertently discovered during the construction of BR-0004. If any previously unknown historic or archaeological resources are encountered during construction activities, the contractor shall immediately halt work and notify the Engineer. The Engineer will immediately notify the Division of Coastal Management (DCM) and the N.C. Department of Cultural and Natural Resources Underwater Archaeology Branch in Kure Beach to initiate the required coordination procedures.

*The contractor shall be made aware that in order to maintain navigation during construction of BR-0004 and demolition of the existing bridge, the authorized temporary work bridges shall be elevated to a minimum vertical clearance of six (6) feet above the normal water level to match the low steel of the existing bridge. In addition, at least one span of the temporary work bridge shall align with Span 8 of the existing bridge to facilitate navigation, as depicted in the workplan drawings in the permit package.

(*-Per Green Sheet Commitments)

PROJECT SPECIAL PROVISIONS**ROADWAY****CLEARING AND GRUBBING - METHOD II:**

(9-17-02)(Rev. 3-19-24)

200

SP2 R02A

Perform clearing on this project to the limits established by Method - II shown on Standard Drawing No. 200.02 of the *Roadway Standard Drawings*. Conventional clearing methods may be used except where permit drawings or conditions have been included in the proposal which require certain areas to be cleared by hand methods.

TEMPORARY DETOURS:

(8-15-00) (Rev. 4-21-15)

1101

SP2 R30A

Construct the temporary detours required on this project in accordance with the typical sections in the plans or as directed by the Engineer.

After the detours have served their purpose, remove the portions deemed unsuitable for use as a permanent part of the project as directed by the Engineer. Salvage and stockpile the aggregate base course removed from the detours at locations within the right of way, as directed by the Engineer, for removal by State Forces. Place pavement and earth material removed from the detour in embankments or dispose of in waste areas furnished by the Contractor.

Pipe culverts removed from the detours remain the property of the Contractor. Pipe culverts that are removed will be measured and will be paid at the contract unit price per linear foot for *Pipe Removal*. Payment for the construction of the detours will be made at the contract unit prices for the various items involved.

No direct payment will be made for removing the aggregate base course, earth material and pavement, as the cost of same shall be included in the lump sum price bid for *Grading*. Such prices and payments will be full compensation for the work of removing, salvaging, and stockpiling aggregate base course; and for placing earth material and pavement in embankments or disposing of earth material and pavement in waste areas.

SHOULDER AND FILL SLOPE MATERIAL:

(5-21-02)(Rev. 1-16-24)

235, 560

SP2 R45 A

Description

Perform the required shoulder and slope construction for this project in accordance with the applicable requirements of Section 560 and Section 235 of the *Standard Specifications*.

Measurement and Payment

Where the material has been obtained from an authorized stockpile or from a borrow source and *Borrow Excavation* is not included in the contract, no direct payment will be made for this work, as the cost of this work will be part of the work being paid at the contract lump sum price for *Grading*. If *Borrow Excavation* is included in this contract and the material has been obtained from an authorized stockpile or from a borrow source, measurement and payment will be as provided in Section 230 of the *Standard Specifications for Borrow Excavation*.

MANUFACTURED QUARRY FINES IN EMBANKMENTS:

(01-17-17)(Rev. 4-16-24)

235

SP02 R72

Description

This specification addresses the use of manufactured quarry fines that are not classified as select materials. The specification allows the Contractor an option, with the approval of the Engineer, to use manufactured quarry fines (MQFs) in embankments as a substitute for conventional borrow material. Furnish and place geotextile for subgrade stabilization in accordance with the contract. Geotextile for subgrade stabilization is required to prevent pavement cracking and provide separation between the subgrade and pavement section at embankment locations where manufactured quarry fines are utilized and as directed by the Engineer.

Materials

Manufactured Quarry Fines.

Site specific approval of MQFs material will be required prior to beginning construction as detailed in the preconstruction requirements of this provision.

The following MQFs are unacceptable:

- (A) Frozen material,
- (B) Material with a maximum dry unit weight of less than 90 pounds per cubic foot when tested in accordance with AASHTO T 99 Method A or C.
- (C) Material with greater than 80% by weight Passing the #200 sieve

Collect and transport MQFs in a manner that will prevent nuisances and hazards to public health and safety. Moisture condition the MQFs as needed and transport in covered trucks to prevent dusting. If MQFs are blended with natural earth material, follow Borrow Criteria in Section 1018 of the *Standard Specifications*.

Preconstruction Requirements

When MQFs are to be used as a substitute for earth borrow material, request written approval from the Engineer at least ninety (90) days in advance of the intent to use MQFs and include the following details:

- (A) Description, purpose and location of project.
- (B) Estimated start and completion dates of project.

- (C) Estimated volume of MQFs to be used on project with specific locations and construction details of the placement.
- (D) The names, address, and contact information for the generator of the MQFs.
- (E) Physical location of the site at which the MQFs were generated.

The Engineer will forward this information to the State Materials Engineer for review and material approval.

Construction Methods

Place MQFs in the core of the embankment section with at least 4 feet of earth cover to the outside limits of the embankments or subgrade.

Construct embankments by placing MQFs in level uniform lifts with no more than a lift of 10 inches and compacted to at least a density of 95 percent as determined by test methods in AASHTO T 99, Determination of Maximum Dry Density and Optimum Moisture Content, Method A or C depending upon particle size of the product. Provide a moisture content at the time of compaction of within 4 percent of optimum but not greater than one percent above optimum as determined by AASHTO T 99, Method A or C.

In embankments where MQFs are incorporated, geotextile for subgrade stabilization shall be used. Refer to Article 505-2 of the *Standard Specifications* for geotextile type and Article 505-3 of the *Standard Specifications* for the geotextile construction methods.

Measurement and Payment

Borrow Excavation will be measured by truck volume and paid in cubic yards in accordance with Article 230-5 of the *Standard Specifications*. As an alternate weigh tickets can be provided and payment made by converting weight to cubic yards based on the verifiable unit weight. Where the pay item for *Borrow Excavation* is not included in the original contract then no separate payment will be made for this item and payment will be included in the lump sum price bid for *Grading*.

Geotextile for Subgrade Stabilization will be measured and paid in accordance with Article 505-4 of the *Standard Specifications*. When the pay item for *Geotextile for Subgrade Stabilization* is not included in the original contract then no payment will be made for this item and will be considered incidental to the use of MQFs in embankment.

CORRUGATED ALUMINUM ALLOY CULVERT PIPE:

(9-21-21)(Rev. 1-16-24)

305, 310

SP3 R34

Revise the *Standard Specifications* as follows:

Page 3-5, Article 305-2, MATERIALS, add the following after line 16:

Item	Section
Waterborne Paint	1080-9
Hot Bitumen	1081-3

Page 3-5, Article 305-3, CONSTRUCTION METHODS, add the following after line 26:

Coating must be applied to the aluminum when in contact with concrete. Immediately prior to coating, aluminum surfaces to be coated shall be cleaned by a method that will remove all dirt, oil, grease, chips, and other foreign substances. Aluminum to be coated shall be given one coat of suitable quality coating such as:

Approved waterborne paint (Section 1080-9)

Approved Hot Bitumen (Section 1081-3)

Other coating materials may be submitted to the Engineer for approval.

Page 3-7, Article 310-6, MEASUREMENT AND PAYMENT, lines 10-11, delete the fourth sentence and replace with the following:

Select bedding and backfill material and coating will be included in the cost of the installed pipe.

BRIDGE APPROACH FILLS:

(10-19-10)(Rev. 1-16-24)

422

SP4 R02

Description

Bridge approach fills consist of backfilling behind bridge end bents with select material or aggregate to support all or part of bridge approach slabs. Install outlets and grade bridge approach fills to drain water through and away from approach fills. Install geotextiles to allow for possible future slab jacking and separate approach fills from embankment fills, natural ground and pavement sections as required. For bridge approach fills behind end bents with mechanically stabilized earth (MSE) abutment walls, reinforce bridge approach fills with MSE wall reinforcement connected to end bent caps as required. Construct bridge approach fills in accordance with the contract, accepted submittals and bridge approach fill *Roadway Standard Drawings*.

Define bridge approach fill types as follows:

Type 1 Approach Fill – Approach fill for bridge abutment in accordance with *Roadway Standard Drawing* No. 423.01;

Type 1A Approach Fill – Alternate approach fill for integral bridge abutment in accordance with *Roadway Standard Drawing* No. 423.02;

Type 2 Approach Fill – Approach fill for bridge abutment with MSE wall in accordance with *Roadway Standard Drawing* No. 423.03 and

Type 2A Approach Fill – Alternate approach fill for integral bridge abutment with MSE wall in accordance with *Roadway Standard Drawing* No. 423.04.

At the Contractors option, use Type 1A or 2A approach fills instead of Type 1 or 2 approach fills, respectively, for integral bridge abutments. Type 1A and 2A approach fills consists of constructing an approach fill with a temporary geotextile wall before placing all or a portion of

the concrete for the backwall and wing walls of the integral end bent cap. The temporary geotextile wall is designed for a construction surcharge, remains in place and is aligned so the wall face functions as a form for the integral end bent cap backwall and wing walls.

Materials

Refer to Division 10 of the *Standard Specifications*.

Item	Section
Geotextiles	1056
Portland Cement Concrete	1000
Select Materials	1016
Subsurface Drainage Materials	1044
Welded Wire Reinforcement	1070-3

Provide Type 1 geotextile for separation geotextiles, Type 4a geotextile for under bridge approach slabs and Class B concrete for outlet pads. Use Class V or Class VI select material for Type 1 and 1A approach fills and the same aggregate type approved for the reinforced zone in the accepted MSE wall submittal for Type 2 and 2A approach fills. For MSE wall aggregate, reinforcement and connector materials, see the *Mechanically Stabilized Earth Retaining Walls* provision. Provide outlet pipes and fittings for subsurface drainage materials. Provide 1/4" hardware cloth with 1/4 inch openings constructed from 24 gauge wire.

For temporary geotextile walls, use welded wire reinforcement for welded wire facing and Type 5a geotextile for reinforcement geotextiles. Use Type 5a geotextile with lengths as shown in *Roadway Standard Drawing* No. 423.02 or 423.04.

Construction Methods

Excavate as necessary for approach fills and, if applicable, temporary geotextile walls in accordance with the contract. Ensure limits of approach fills are graded to drain as shown in the bridge approach fill *Roadway Standard Drawings*. For Type 1 and 1A approach fills in embankment fills, place and compact a temporary 1.5:1 (H:V) fill slope in accordance with *Roadway Standard Drawing* No. 423.01 or 423.02 and in accordance with Subarticle 235-3(B) and 235-3(C) of the *Standard Specifications*. Density testing is required within the temporary fill slope and additional more frequent density testing is also required for bridge approach embankments. Wait 3 days before cutting the slope back to complete the approach fill excavation. Use excavated material elsewhere on the project to form embankments, subgrades, or shoulders. If a slope for an approach fill is excavated to flatter than what is required for access or any other reason, that same slope is required for the entire approach fill excavation. Do not backfill overexcavations that extend outside the approach fill limits shown on the *Roadway Standard Drawings* with embankment soils. Instead, expand approach fill limits to include overexcavations.

Notify the Engineer when embankment fill placement and approach fill excavation is complete. Do not place separation geotextiles or aggregate until approach fill dimensions and embankment materials below and outside approach fills are approved.

For Type 2 approach fills, cast MSE wall reinforcement or connectors into end bent cap backwalls within 3 inches of locations shown in the accepted MSE wall submittals. Install MSE wall reinforcement with the orientation, dimensions and number of layers shown in the accepted MSE wall submittals. If a Type 2 approach fill is designed with geogrid reinforcement embedded in an end bent cap, cut geogrids to the required lengths and after securing ends of geogrids in place, reroll and rewrap portions of geogrids not embedded in the cap to protect geogrids from damage. Before placing aggregate over any MSE wall geosynthetic reinforcement, pull reinforcement taut so that it is in tension and free of kinks, folds, wrinkles or creases.

For Type 1 and 1A approach fills, place pipe sleeves in wing walls so water drains towards outlets. Use sleeves that can withstand wing wall loads. Insert outlet pipes into pipe sleeves to direct water towards outlets. Attach hardware cloth in front of the outlet pipe at the wing. Connect outlet pipes and fittings with solvent cement in accordance with Article 815-3 of the *Standard Specifications* and place outlet pads in accordance with Roadway Standard Drawing No. 815.03.

Attach separation geotextiles to end bent cap backwalls and wing walls with adhesives, tapes or other approved methods. Overlap adjacent geotextiles of the same type at least 18 inches. Cover select material or aggregate with Type 4a geotextile at an elevation 6 inches below the bridge approach slab. Hold geotextiles in place with wire staples or anchor pins as needed. Contact the Engineer when existing or future obstructions such as foundations, pavements, pipes, inlets or utilities will interfere with geotextiles or MSE wall reinforcement.

For Type 1A and 2A approach fills, install temporary geotextile walls as shown in *Roadway Standard Drawing* No. 423.02 or 423.04. At the Contractor's option, construct the bottom portion of integral end bents before temporary geotextile walls as shown in the plans. Erect and set welded wire facing for temporary geotextile walls so facing functions as a form for the integral end bent cap backwall. Place welded wire facing adjacent to each other in the horizontal and vertical directions to completely cover the temporary geotextile wall face. Stagger welded wire facing to create a running bond by centering facing over joints in the row below. Wrap reinforcement geotextiles at the wall face in accordance with *Roadway Standard Drawing* No. 423.02 or 423.04 and cover geotextiles with at least 3 inches of select material or aggregate. Place layers of reinforcement geotextiles within 3 inches of locations shown in *Roadway Standard Drawing* No. 423.02 or 423.04. Install reinforcement geotextiles with the direction shown in *Roadway Standard Drawing* No. 423.02 or 423.04. Orient overlapping seams in reinforcement geotextiles perpendicular to the integral end bent cap backwall. Do not overlap reinforcement geotextiles so seams are parallel to the wall face. Before placing select material or aggregate over reinforcement geotextiles, pull geotextiles taut so they are in tension and free of kinks, folds, wrinkles or creases. Temporary geotextile walls are designed for a surcharge pressure in accordance with *Roadway Standard Drawing* No. 423.02 or 423.04. If loads from construction equipment will be more than what the wall is designed for, contact the Engineer before positioning equipment on top of temporary geotextile walls.

Place select material or aggregate in 6 inch to 8 inch thick lifts. Compact fine aggregate for Type 2 and 2A approach fills in accordance with Subarticle 235-3(C) of the *Standard Specifications* except compact fine aggregate to a density of at least 98%. Compact select material for Type 1 and 1A approach fills and coarse aggregate for Type 2 and 2A approach fills

with at least 4 passes of a trench roller in a direction parallel to the end bent cap backwall. Do not displace or damage geosynthetics or MSE wall reinforcement when placing and compacting select material or aggregate. End dumping directly on geosynthetics is not permitted. Do not operate heavy equipment on geosynthetics until they are covered with at least 8 inches of select material or aggregate. Replace any damaged geosynthetics to the satisfaction of the Engineer. When approach fills extend beyond bridge approach slabs, wrap Type 4a geotextiles over select material or aggregate and back under approach slabs as shown in *Roadway Standard Drawing* No. 423.03 or 423.04.

Measurement and Payment

Type 1 and 1A approach fills will be paid for at the contract lump sum price for *Type 1 Bridge Approach Fill, Station _____* and Type 2 and 2A approach fills will be paid for at the contract lump sum price for *Type 2 Bridge Approach Fill, Station _____*. The lump sum price for each approach fill will be full compensation for providing labor, tools, equipment and approach fill materials, excavating, backfilling, hauling and removing excavated materials, installing wall facing, geotextiles and outlets, compacting backfill and supplying select material, aggregate, geotextiles, pipe sleeves, outlet pipes and pads and any incidentals necessary to construct approach fills behind bridge end bents.

Compensation for the material placed within the temporary 1.5:1 (H:V) fill slopes will be made in accordance with Section 225, 226, or 230 of the *Standard Specifications*. The cost of removal, including excavating, hauling, placement, and compaction of the material elsewhere on or off the project will be included in the contract lump sum price for *Type 1 Bridge Approach Fill, Station _____*.

The contract lump sum price for *Type 2 Bridge Approach Fill, Station _____* will also be full compensation for supplying and connecting MSE wall reinforcement to end bent caps but not designing MSE wall reinforcement and connectors. The cost of designing reinforcement and connectors for Type 2 approach fills behind bridge end bents with MSE abutment walls will be incidental to the contract unit price for *MSE Retaining Wall No. _____*.

Payment will be made under:

Pay Item	Pay Unit
Type 1 Bridge Approach Fill, Station _____	Lump Sum
Type 2 Bridge Approach Fill, Station _____	Lump Sum

STABILIZATION OF COASTAL PLAIN SANDS:

(11-18-14)

510

SP5 R12

Description

As directed by the Engineer, stabilize sandy subgrade material with Class IV aggregate to prevent rutting of the subgrade prior to paving directly on the subgrade. Remove material as needed in cut areas prior to placing the Class IV aggregate.

Materials

Refer to Division 10.

Item

Select Material, Class IV

Section

1016

Use Class IV Select Material for Class IV Aggregate Stabilization.

Construction Methods**Class IV Aggregate Stabilization**

As directed by the Engineer, place aggregate by end dumping aggregate on approved subgrade soils to provide a working platform and reduce wheel rutting of subgrade material. Place the Class IV aggregate stabilization to a thickness of 2 to 3 inches.

Maintenance

Maintain aggregate stabilization in an acceptable condition and minimize the use of heavy equipment on aggregate in order to avoid damaging the subgrade. Provide and maintain drainage ditches and drains as required to prevent entrapping water in aggregate stabilization.

Measurement and Payment

Class IV Aggregate Stabilization will be measured and paid in tons. Aggregate will be measured by weighing in trucks in accordance with Article 106-7. The contract unit price for *Class IV Aggregate Stabilization* will be full compensation for furnishing, hauling, handling, placing, mixing, compacting and maintaining aggregate.

The work to excavate material to place Class IV Aggregate Stabilization below subgrade is considered incidental to the work of placing the aggregate and no separate payment will be made.

Payment will be made under:

Pay Item

Class IV Aggregate Stabilization

Pay Unit

Ton

PRICE ADJUSTMENT - ASPHALT BINDER FOR PLANT MIX:

(11-21-00)(Rev. 1-16-24)

620

SP6 R25

Price adjustments for asphalt binder for plant mix will be made in accordance with Section 620 of the *Standard Specifications*.

The base price index for asphalt binder for plant mix is \$ **685.00** per ton.

This base price index represents an average of F.O.B. selling prices of asphalt binder at supplier's terminals on **April 1, 2026**.

DELETION OF FINAL SURFACE TESTING REQUIREMENTS:

(1-20-25)

610

SP6 R045A

Revise the *Standard Specifications* as follows:

Pages 6-24 to 6-30, Article 610-13 FINAL SURFACE TESTING AND ACCEPTANCE, delete Article 610-13 in its entirety.

ELECTRONIC TICKETING SYSTEM:

(7-16-24)(Rev. 12-17-24)

1020

SP10 R20

Description

At the contractor's option, the use of an electronic ticketing system for reporting individual and cumulative asphalt material deliveries may be utilized on this project. At the preconstruction conference, the contractor shall notify the Engineer if they intend to utilize an electronic ticketing system for reporting individual and cumulative asphalt material deliveries to the project.

Electronic Ticketing Requirements

- a. The electronic ticketing system must be fully integrated with the load read-out system at the plant. The system shall be designed so data inputs from scales cannot be altered by either the Contractor or the Department.
- b. Material supplier must test to confirm that ticketing data can be shared from the originating system no less than 30 days prior to project start.
- c. After each truck is loaded, ticket data must be electronically captured, and ticket information uploaded via Application Programming Interface (API) to the Department.
- d. Obtain security token from NCDOT for access to E-Ticketing portal (to send tickets). To request a Security Key, fill out the below E-Ticketing Security Request Form: <https://forms.office.com/g/XnT7QeRtgt>
- e. Obtain API from NCDOT containing the required e-ticketing data fields and format. Download the API from the NCDOT E-ticketing Webpage: <https://connect.ncdot.gov/projects/construction/E-Ticketing/Pages/default.aspx>
- f. Provide all ticket information in real time and daily summaries to the Department's designated web portal. If the project contains locations with limited cellular service, an alternative course of action must be agreed upon.
- g. Electronic ticketing submissions must be sent between the Material Supplier and the Department.
- h. The electronic ticket shall contain the following information:

Date
Contract Number
Supplier Name
Contractor Name
Material
JMF
Gross Weight
Tare Weight
Net Weight
Load Number
Cumulative Weight
Truck Number
Weighmaster Certification
Weighmaster Expiration
Weighmaster Name
Facility Name
Plant Certification Number
Ticket Number
Hauling Firm (optional)
Voided Ticket Number (if necessary)
Original Ticket Number (if necessary)
Supplier Revision (If necessary)

The Contractor/supplier can use the electronic ticketing system of their choice to meet the requirements of this provision.

Measurement and Payment

No measurement or payment will be made for utilizing an electronic ticketing system as the cost of such shall be included in the contract price bid for the material being provided.

TIMBER AND LUMBER:

(4-21-26)

235, 866, 1046, 1050, 1082, 1084, 1089, 1540

SP10 R82

Page 2-23, Article 235-2 MATERIALS, line 26, add the following as the third sentence of the fourth paragraph.

Use pressure treated wood bases meeting the requirements of Section 1082.

Page 8-45, Article 866-2 MATERIALS, line 26, replace “1076-7” with “1050-8”.

Page 10-73, Subarticle 1046-3(C) Treated Timber Posts, line 8, replace “treated southern pine” with “pressure treated southern pine”.

Page 10-76, Subarticle 1050-2(A) General, line 3, replace “Use treated southern pine meeting Articles 1082-2 and 1082-3” with “Use pressure treated southern pine meeting Articles 1082-2 and 1082-3”.

Page 10-76, Subarticle 1050-2(A) General, lines 15-16, replace “All round posts” with “All round wood posts and braces”.

Page 10-76, Subarticle 1050-2(A) General, lines 19-20, delete the last sentence of the third paragraph and replace with the following:

The pieces shall show at least 3 annual rings per inch and shall be at least 30% summerwood. All timber and lumber shall conform to the material characteristics detailed in the Southern Pine Inspection Bureau (SPIB) grading rules for the designated grade and may bear the mark of an American Lumber Standards Committee (ALSC) accredited agency.

Page 10-177, Article 1082-1 GENERAL, lines 32-33, delete the first sentence of the first paragraph and replace with the following:

Use southern pine timber and lumber graded in accordance with the current grading rules of the SPIB and manufactured by a Department pre-approved producer/supplier. All timber and lumber shall conform to the material characteristics detailed in the SPIB grading rules for No. 1 Dense or Select Structural (Sel Str.) and bear the mark of an ALSC-accredited agency.

Page 10-177 and 10-178, Article 1082-1 GENERAL, lines 38-42 and line 1, delete the second through fourth sentence of the second paragraph and replace with the following:

Use approved inspection companies listed on the Department’s pre-approved producer/suppliers list. The inspection agency must perform inspections of preservative treated materials in accordance with AWPAs Standard M2. Each item shall bear the brand, hammer mark, ink stamp or tag of the inspection agency to indicate it has been inspected. In lieu of commercial inspection, materials in Section 1082 manufactured by a facility that is audited by an ALSC-accredited agency and bearing the quality mark of that agency shall be acceptable for use. In addition, the Supplier must furnish Type 4 – Certified Test Reports and Type 6 – Supplier’s Certifications in accordance with Article 106-3. Type 6 – Supplier’s Certifications are required

for each producer/supplier to include any chain of custody changes from the mill to the Department.

Page 10-178, Article 1082-2 UNTREATED TIMBER AND LUMBER, line 7, replace “Dense” with “Grade No. 1 Dense MC19”.

Page 10-178, Subarticle 1082-3(A) General, line 13, replace “lumber” with “timber and lumber” and replace “will not” with “with”.

Page 10-178, Subarticle 1082-3(B) Bridges, Fender Systems and Piles, lines 22 and 24, replace “Grade No. 1 Dense” with “Grade No. 1 Dense or Select Structural (Sel Str.)”.

Page 10-178, Subarticle 1082-3(B) Bridges, Fender Systems and Piles, lines 24-27, delete the third and fourth sentence of the first paragraph and replace with the following:

Timbers for bridges or fender systems that are 5 inches and thicker along the least dimension shall conform to Grade No. 1 Dense or Select Structural (Sel Str.).

Page 10-178, Subarticle 1082-3(B) Bridges, Fender Systems and Piles, line 28, delete and replace the second paragraph with the following:

Timber for piles shall be southern pine and meet the requirements of ASTM D25.

Page 10-178, Subarticle 1082-3(C) Guardrail Posts, Blockouts and related components, lines 33-34, replace “Southern Pine, conforming to Grade No. 1. Rough lumber will be acceptable.” with “southern pine, conforming to Grade No. 1 Dense.”.

Page 10-178, Subarticle 1082-3(D) Fence Posts and Braces, lines 37-39, delete the first paragraph and replace with the following:

Sawn fence posts and braces shall be southern pine, S4S, and conform to Grade No. 1 Dense.

Page 10-178, Subarticle 1082-3(E) Sign Posts and Battens, lines 42-44, delete the first and second sentence of the first paragraph and replace with the following:

Lumber or timbers for sign posts shall conform to Structural Light Framing, Grade No. 1 Dense.

Page 10-178, Subarticle 1082-3(E) Sign Posts and Battens, line 46, delete the first sentence of the second paragraph.

Page 10-179, Subarticle 1082-3(F) Poles, lines 2-3, delete the first sentence of the first paragraph and replace with the following:

Timber for poles shall be either treated southern pine or coastal douglas-fir and meet the requirements of ANSI O5.1.

Page 10-179, Subarticle 1082-4(A) General, line 8, replace “AASHTO M 133 or AWPA Standards” with “AASHTO M 133 and AWPA Standards”.

Page 10-179, Subarticle 1082-4(A) General, lines 14-15, delete the third paragraph.

Page 10-179, Subarticle 1082-4(A) General, line 19, replace “”areas include” with “areas including, but not limited to,”.

Page 10-179, Subarticle 1082-4(B) Timber Preservatives, line 24, replace “AASHTO M 133 or AWPA Standards U1” with “AASHTO M 133 and AWPA Standards U1”.

Page 10-179, Subarticle 1082-4(C) Bridges, Fender Systems and Piles, lines 27-28, replace “AASHTO M-133 or AWPA Standard U1” with “AASHTO M 133 and AWPA Standard U1”.

Page 10-179, Subarticle 1082-4(D) Guardrail Posts, Blockouts and Related Components, lines 32-33, replace “AASHTO M-133 or AWPA Standard U1” with “AASHTO M 133 and AWPA Standard U1”.

Page 10-179, Subarticle 1082-4(E) Fence Posts and Braces, lines 36 and 38, replace “AASHTO M-133 or AWPA Standard U1” with “AASHTO M 133 and AWPA Standard U1”.

Page 10-179, Subarticle 1082-4(E) Fence Posts and Braces, line 39, replace “except require retention of preservative as below” with “Commodity Specification B. Posts, UC4A”.

Page 10-180, Subarticle 1082-4(F) Sign Posts and Battens, line 2, replace “AASHTO M-133 or AWPA Standard U1” with “AASHTO M 133 and AWPA Standard U1”.

Page 10-180, Subarticle 1082-4(G) Poles, line 9, replace “AASHTO M-133 or AWPA Standard U1” with “AASHTO M 133 and AWPA Standard U1”.

Page 10-180, Subarticle 1084-1(A) Treated Timber Pile, line 16-17, delete and replace the first paragraph with the following:

Treated timber piles shall meet the requirements of Section 1082.

Page 10-195, Subarticle 1089-2(A)(1) Work Zone Signs (Stationary), line 44, add the following sentence to the second paragraph:

Pressure treat wood posts in accordance with Section 1082.

Page 15-18, Article 1540-2 MATERIALS, line 8, replace “1082-3” with “1082”.

TEMPORARY SHORING:

(2-20-07)(Rev. 1-16-24)

SP11 R02

Description

Temporary shoring includes cantilever, braced and anchored shoring and temporary mechanically stabilized earth (MSE) walls. Temporary shoring does not include trench boxes. At the Contractor's option, use any type of temporary shoring unless noted otherwise in the plans or as directed. Design and construct temporary shoring based on actual elevations and shoring dimensions in accordance with the contract and accepted submittals. Construct temporary shoring at locations shown in the plans and as directed. Temporary shoring is required to maintain traffic when a 2:1 (H:V) slope from the top of an embankment or bottom of an excavation will intersect the existing ground line less than 5 feet from the edge of pavement of an open travelway. This provision does not apply to pipe, inlet or utility installation unless noted otherwise in the plans.

Positive protection includes concrete barrier and temporary guardrail. Provide positive protection for temporary shoring at locations shown in the plans and as directed. Positive protection is required if temporary shoring is located in the clear zone in accordance with the *AASHTO Roadside Design Guide*.

(A) Cantilever and Braced Shoring

Cantilever shoring consists of steel sheet piles or H-piles with timber lagging. Braced shoring consists of sheet piles or H-piles with timber lagging and bracing such as beams, plates, walers, struts, rakers, etc. Define "piles" as sheet piles or H-piles.

(B) Anchored Shoring

Anchored shoring consists of sheet piles with walers or H-piles with timber lagging anchored with ground or helical anchors. Driven anchors may be accepted at the discretion of the Engineer. A ground anchor consists of a grouted steel bar or multi-strand tendon with an anchorage. A helical anchor consists of a lead section with a central steel shaft and at least one helix steel plate followed by extensions with only central shafts (no helixes) and an anchorage. Anchorages consist of steel bearing plates with washers and hex nuts for bars or steel wedge plates and wedges for strands. Use a prequalified Anchored Wall Contractor to install ground anchors. Define "anchors" as ground, helical or driven anchors.

(C) Temporary MSE Walls

Temporary MSE walls include temporary geosynthetic and wire walls. Define "temporary wall" as a temporary MSE wall and "Temporary Wall Vendor" as the vendor supplying the temporary MSE wall. Define "reinforcement" as geotextile, geogrid, geostrip, welded wire grid or metallic strip reinforcement.

Temporary geosynthetic walls consist of geotextiles or geogrids wrapped behind welded wire facing or geostrips connected to welded wire facing. Define "temporary geotextile wall" as a temporary geosynthetic wall with geotextile reinforcement, "temporary

geogrid wall” as a temporary geosynthetic wall with geogrid reinforcement and “temporary geostrip wall” as a temporary geosynthetic wall with geostrip reinforcement.

Temporary wire walls consist of welded wire grid or metallic strip reinforcement connected to welded wire facing. Define “Wire Wall Vendor” as the vendor supplying the temporary wire wall.

(D) Embedment

Define “embedment” for cantilever, braced and anchored shoring as the pile depth below the grade in front of shoring. Define “embedment” for temporary walls as the wall embedment below the grade at the wall face.

(E) Positive Protection

Define “unanchored or anchored portable concrete barrier” as portable concrete barrier (PCB) that meets *Roadway Standard Drawing* No. 1170.01. Define “concrete barrier” as unanchored or anchored PCB or an approved equal. Define “temporary guardrail” as temporary steel beam guardrail that meets *Roadway Standard Drawing* No. 862.02.

Materials

Refer to the *Standard Specifications*.

Item	Section
Concrete Barrier Materials	1170-2
Flowable Fill, Excavatable	1000-7
Geosynthetics	1056
Grout, Type 1	1003
Portland Cement	1024-1
Portland Cement Concrete	1000
Select Materials	1016
Steel Beam Guardrail Materials	862-2
Steel Plates	1072-2
Steel Sheet Piles and H-Piles	1084
Untreated Timber	1082-2
Water	1024-4
Welded Wire Reinforcement	1070-3

Provide Type 6 material certifications for shoring materials in accordance with Article 106-3 of the *Standard Specifications*. Use Class IV select material for temporary guardrail and Class A concrete that meets Article 450-2 of the *Standard Specifications* or Type 1 grout for drilled-in piles. Provide untreated timber with a thickness of at least 3 inches and a bending stress of at least 1,000 pounds per square inch for timber lagging. Provide steel bracing that meets ASTM A36.

(A) Shoring Backfill

Use Class II, Type 1, Class III, Class V or Class VI select material or material that meets AASHTO M 145 for soil classification A-2-4 with a maximum PI of 6 for shoring backfill except do not use A-2-4 soil for backfill around culverts.

(B) Anchors

Store anchor materials on blocking a minimum of 12 inches above the ground and protect it at all times from damage; and when placing in the work make sure it is free from dirt, dust, loose mill scale, loose rust, paint, oil or other foreign materials. Load, transport, unload and store anchor materials so materials are kept clean and free of damage. Bent, damaged or defective materials will be rejected.

(1) Ground Anchors

Use high-strength deformed steel bars that meet AASHTO M 275 or seven-wire strands that meet ASTM A886 or Article 1070-5 of the *Standard Specifications*. Splice bars in accordance with Article 1070-9 of the *Standard Specifications*. Do not splice strands. Use bondbreakers, spacers and centralizers that meet Article 6.3.5 of the *AASHTO LRFD Bridge Construction Specifications*.

Use neat cement grout that only contains cement and water with a water cement ratio of 0.4 to 0.5 which is approximately 5.5 gallons of water per 94 pounds of Portland cement. Provide grout with a compressive strength at 3 and 28 days of at least 1,500 and 4,000 psi, respectively.

(2) Helical Anchors

Use helical anchors with an ICC Evaluation Service, Inc. (ICC-ES) report. Provide couplers, thread bar adapters and bolts recommended by the Anchor Manufacturer to connect helical anchors together and to piles.

(3) Anchorages

Provide steel plates for bearing plates and steel washers, hex nuts, wedge plates and wedges recommended by the Anchor Manufacturer.

(C) Temporary Walls

(1) Welded Wire Facing

Use welded wire reinforcement for welded wire facing, struts and wires. For temporary wire walls, provide welded wire facing supplied by the Wire Wall Vendor or a manufacturer approved or licensed by the vendor. For temporary wire walls with separate reinforcement and facing components, provide connectors (e.g., bars, clamps, plates, etc.) and fasteners (e.g., bolts, nuts, washers, etc.) required by the Wire Wall Vendor.

(2) Geotextiles

Provide Type 2 geotextile for separation and retention geotextiles. Provide Type 5a geotextile for geotextile reinforcement with ultimate tensile strengths in accordance with the accepted submittals.

(3) Geogrid and Geostrip Reinforcement

Use geogrids with a roll width of at least 4 feet. Use geogrids for geogrid reinforcement and geostrips for geostrip reinforcement with an “approved” status code in accordance with the NCDOT Geosynthetic Reinforcement Evaluation Program. The list of approved geogrids and geostrips is available from:

connect.ncdot.gov/resources/Geological/Pages/Products.aspx

Provide geogrids and geostrips with design strengths in accordance with the accepted submittals. Geogrids and geostrips are approved for short-term design strengths (3-year design life) in the machine direction (MD) and cross-machine direction (CD) based on material type. Define material type from the website above for shoring backfill as follows:

Material Type	Shoring Backfill
Borrow	A-2-4 Soil
Fine Aggregate	Class II, Type 1 or Class III Select Material
Coarse Aggregate	Class V or VI Select Material

(4) Welded Wire Grid and Metallic Strip Reinforcement

Provide welded wire grid and metallic strip reinforcement supplied by the Wire Wall Vendor or a manufacturer approved or licensed by the vendor. Use welded wire grid reinforcement (“mesh”, “mats” and “ladders”) that meet Article 1070-3 of the *Standard Specifications* and metallic strip reinforcement (“straps”) that meet ASTM A572 or A1011.

Preconstruction Requirements

(A) Concrete Barrier

Define “clear distance” behind concrete barrier as the horizontal distance between the barrier and edge of pavement. The minimum required clear distance for concrete barrier is shown in the plans. At the Contractor’s option or if the minimum required clear distance is not available, set concrete barrier next to and up against traffic side of temporary shoring except for barrier above temporary walls. Concrete barrier with the minimum required clear distance is required above temporary walls.

(B) Temporary Guardrail

Define “clear distance” behind temporary guardrail as the horizontal distance between guardrail posts and temporary shoring. At the Contractor’s option or if clear distance for cantilever, braced and anchored shoring is less than 4 feet, attach guardrail to traffic side

of shoring as shown in the plans. Place ABC in clear distance and around guardrail posts instead of pavement. Do not use temporary guardrail above temporary walls.

(C) Temporary Shoring Designs

Before beginning temporary shoring design, survey existing ground elevations in the vicinity of shoring locations to determine actual design heights (H). Submit PDF files of working drawings and design calculations for temporary shoring designs in accordance with Article 105-2 of the *Standard Specifications*. Submit working drawings showing plan views, shoring profiles, typical sections and details of temporary shoring design and construction sequence. Do not begin shoring construction until a design submittal is accepted.

Have cantilever and braced shoring designed, detailed and sealed by an engineer licensed in the state of North Carolina. Use a prequalified Anchored Wall Design Consultant to design anchored shoring. Provide anchored shoring designs sealed by a Design Engineer approved as a Geotechnical Engineer (key person) for an Anchored Wall Design Consultant. Include details in anchored shoring working drawings of anchor locations and lock-off loads, unit grout/ground bond strengths for ground anchors or minimum installation torque and torsional strength rating for helical anchors and if necessary, obstructions extending through shoring or interfering with anchors. Include details in the anchored shoring construction sequence of pile and anchor installation, excavation and anchor testing.

Provide temporary wall designs sealed by a Design Engineer licensed in the state of North Carolina and employed or contracted by the Temporary Wall Vendor. Include details in temporary wall working drawings of geotextile and reinforcement types, locations and directions and obstructions extending through walls or interfering with reinforcement.

(1) Soil Parameters

Design temporary shoring for the assumed soil parameters and groundwater or flood elevations shown in the plans. Assume the following soil parameters for shoring backfill:

(a) Unit weight (γ) = 120 pcf,

(b)	Friction Angle (ϕ)	Shoring Backfill
	30°	A-2-4 Soil
	34°	Class II, Type 1 or Class III Select Material
	38°	Class V or VI Select Material

(c) Cohesion (c) = 0 psf.

(2) Traffic Surcharge

Design temporary shoring for a traffic surcharge of 250 pounds per square foot if

traffic will be above and within H of shoring. This traffic surcharge does not apply to construction traffic. Design temporary shoring for any construction surcharge if construction traffic will be above and within H of shoring. Design temporary shoring for a traffic (live load) surcharge in accordance with Article 11.5.6 of the *AASHTO LRFD Bridge Design Specifications*.

(3) Cantilever, Braced and Anchored Shoring Designs

Use shoring backfill for fill sections and voids between cantilever, braced and anchored shoring and the critical failure surface. Use concrete or Type 1 grout for embedded portions of drilled-in H-piles. Do not use drilled-in sheet piles.

Define “top of shoring” for cantilever, braced and anchored shoring as where the grade intersects the back of sheet piles or H-piles and timber lagging. Design cantilever, braced and anchored shoring for a traffic impact load of 2,000 pounds per foot applied 18 inches above top of shoring if concrete barrier is above and next to shoring or temporary guardrail is above and attached to shoring. Extend cantilever, braced and anchored shoring at least 32 inches above top of shoring if shoring is designed for traffic impact. Otherwise, extend shoring at least 6 inches above top of shoring.

Design cantilever, braced and anchored shoring for a maximum deflection of 3 inches if the horizontal distance to the closest edge of pavement or structure is less than H. Otherwise, design shoring for a maximum deflection of 6 inches. Design cantilever and braced shoring in accordance with the plans and *AASHTO Guide Design Specifications for Bridge Temporary Works*.

Design anchored shoring in accordance with the plans and Article 11.9 of the *AASHTO LRFD Bridge Design Specifications*. Use a resistance factor of 0.80 for tensile resistance of anchors with bars, strands or shafts. Extend the unbonded length for ground anchors and the shallowest helix for helical anchors at least 5 feet behind the critical failure surface. Do not extend anchors beyond right-of-way or easement limits. If existing or future obstructions such as foundations, guardrail posts, pavements, pipes, inlets or utilities will interfere with anchors, maintain a clearance of at least 6 inches between obstructions and anchors.

(4) Temporary Wall Designs

Use shoring backfill in the reinforced zone of temporary walls. Separation geotextiles are required between shoring backfill and backfill, natural ground or culverts along the sides of the reinforced zone perpendicular to the wall face. For Class V or VI select material in the reinforced zone, separation geotextiles are also required between shoring backfill and backfill or natural ground on top of and at the back of the reinforced zone.

Design temporary walls in accordance with the plans and Article 11.10 of the *AASHTO LRFD Bridge Design Specifications*. Embed temporary walls at least 18 inches except for walls on structures or rock as determined by the Engineer. Use

a uniform reinforcement length throughout the wall height of at least 0.7H or 6 feet, whichever is longer. Extend the reinforced zone at least 6 inches beyond end of reinforcement. Do not locate the reinforced zone outside right-of-way or easement limits.

Use the simplified method for determining maximum reinforcement loads in accordance with the AASHTO LRFD specifications. For geotextile reinforcement, use geotextile properties approved by the Department or default values in accordance with the AASHTO LRFD specifications. For geogrid and geostrip reinforcement, use approved geosynthetic reinforcement properties available from the website shown elsewhere in this provision. Use geosynthetic properties for the direction reinforcement will be installed, a 3-year design life and shoring backfill to be used in the reinforced zone.

Do not use more than 4 different reinforcement strengths for each temporary geosynthetic wall. Design temporary geotextile walls for a reinforcement coverage ratio (R_c) of 1.0. For temporary geogrid walls with an R_c of less than 1.0, use a maximum horizontal clearance between geogrids of 3 feet and stagger reinforcement so geogrids are centered over gaps in the reinforcement layer below.

For temporary geosynthetic walls, use “L” shaped welded wire facing with 18 to 24 inch long legs. Locate geosynthetic reinforcement so reinforcement layers are at the same level as the horizontal legs of welded wire facing. Use vertical reinforcement spacing equal to facing height. Wrap geotextile or geogrid reinforcement behind welded wire facing and extend reinforcement at least 3 feet back behind facing into shoring backfill. Attach geostrip reinforcement to welded wire facing with a connection approved by the Department.

For temporary wire walls with separate reinforcement and facing components, attach welded wire grid or metallic strip reinforcement to welded wire facing with a connection approved by the Department. For temporary geogrid, geostrip and wire walls, retain shoring backfill at welded wire facing with retention geotextiles and extend geotextiles at least 3 feet back behind facing into backfill.

(D) Preconstruction Meeting

The Engineer may require a shoring preconstruction meeting to discuss the construction, inspection and testing of the temporary shoring. If required and if this meeting occurs before all shoring submittals have been accepted, additional preconstruction meetings may be required before beginning construction of temporary shoring without accepted submittals. The Resident, District or Bridge Maintenance Engineer, Area Construction Engineer, Geotechnical Operations Engineer, Contractor and Shoring Contractor Superintendent will attend preconstruction meetings.

Construction Methods

Control drainage during construction in the vicinity of shoring. Direct run off away from shoring and shoring backfill. Contain and maintain backfill and protect material from erosion.

Install positive protection in accordance with the contract and accepted submittals. Use PCB in accordance with Section 1170 of the *Standard Specifications* and *Roadway Standard Drawing* No. 1170.01. Use temporary guardrail in accordance with Section 862 of the *Standard Specifications* and *Roadway Standard Drawing* Nos. 862.01, 862.02 and 862.03.

(A) Tolerances

Construct shoring with the following tolerances:

- (1) Horizontal wires of welded wire facing are level in all directions,
- (2) Shoring location is within 6 inches of horizontal and vertical alignment shown in the accepted submittals, and
- (3) Shoring plumbness (batter) is not negative and within 2 degrees of vertical.

(B) Cantilever, Braced and Anchored Shoring Installation

If overexcavation behind cantilever, braced or anchored shoring is shown in the accepted submittals, excavate before installing piles. Otherwise, install piles before excavating for shoring. Install cantilever, braced or anchored shoring in accordance with the construction sequence shown in the accepted submittals. Remove piles and if applicable, timber lagging when shoring is no longer needed.

(1) Pile Installation

Install piles with the minimum required embedment and extension in accordance with Subarticles 450-3(D) and 450-3(E) of the *Standard Specifications* except that a pile driving equipment data form is not required. Piles may be installed with a vibratory hammer as approved by the Engineer.

Do not splice sheet piles. Use pile excavation to install drilled-in H-piles. After filling holes with concrete or Type 1 grout to the elevations shown in the accepted submittals, remove any fluids and fill remaining portions of holes with flowable fill. Cure concrete or grout at least 7 days before excavating.

Notify the Engineer if refusal is reached before pile excavation or driven piles attain the minimum required embedment. When this occurs, a revised design submittal may be required.

(2) Excavation

Excavate in front of piles from the top down in accordance with the accepted

submittals. For H-piles with timber lagging and braced and anchored shoring, excavate in staged horizontal lifts with a maximum height of 5 feet. Remove flowable fill and material in between H-piles as needed to install timber lagging. Position lagging with at least 3 inches of contact in the horizontal direction between the lagging and pile flanges. Do not excavate the next lift until timber lagging for the current lift is installed and if applicable, bracing and anchors for the current lift are accepted. Backfill behind cantilever, braced or anchored shoring with shoring backfill.

(3) Anchor Installation

If applicable, install foundations located behind anchored shoring before installing anchors. Fabricate and install ground anchors in accordance with the accepted submittals, Articles 6.4 and 6.5 of the *AASHTO LRFD Bridge Construction Specifications* and the following unless otherwise approved:

- (a) Materials in accordance with this provision are required instead of materials conforming to Articles 6.4 and 6.5.3 of the AASHTO LRFD Specifications,
- (b) Encapsulation-protected ground anchors in accordance with Article 6.4.1.2 of the AASHTO LRFD specifications are not required, and
- (c) Corrosion protection for unbonded lengths of ground anchors and anchorage covers are not required.
- (d) Mix and place neat cement grout in accordance with Subarticles 1003-5, 1003-6 and 1003-7 of the *Standard Specifications*. Measure grout temperature, density and flow during grouting with at least the same frequency grout cubes are made for compressive strength. Perform density and flow field tests in the presence of the Engineer in accordance with American National Standards Institute/American Petroleum Institute Recommended Practice 13B-1 (Section 4, Mud Balance) and ASTM C939 (Flow Cone), respectively.

Install helical anchors in accordance with the accepted submittals and Anchor Manufacturer's instructions. Measure torque during installation and do not exceed the torsional strength rating of the helical anchor. Attain the minimum required installation torque and penetration before terminating anchor installation. When replacing a helical anchor, embed last helix of the replacement anchor at least 3 helix plate diameters past the location of the first helix of the previous anchor.

(4) Anchor Testing

Proof test and lock-off anchors in accordance with the accepted submittals and Article 6.5.5 of the *AASHTO LRFD Bridge Construction Specifications* except for the acceptance criteria in Article 6.5.5.5. For the AASHTO LRFD specifications,

“ground anchor” refers to a ground or helical anchor and “tendon” refers to a bar, strand or shaft.

(a) Anchor Acceptance

Anchor acceptance is based in part on the following criteria.

- (i) For ground and helical anchors, total movement is less than 0.04 inches between the 1 and 10 minute readings or less than 0.08 inches between the 6 and 60 minute readings.
- (ii) For ground anchors, total movement at maximum test load exceeds 80% of the theoretical elastic elongation of the unbonded length.

(b) Anchor Test Results

Submit PDF files of anchor test records including movement versus load plots for each load increment within 24 hours of completing each row of anchors. The Engineer will review the test records to determine if the anchors are acceptable.

If the Engineer determines an anchor is unacceptable, revise the anchor design or installation methods. Submit a revised anchored shoring design for acceptance and provide an acceptable anchor with the revised design or installation methods. If required, replace the anchor or provide additional anchors with the revised design or installation methods.

(C) Temporary Wall Installation

Excavate as necessary for temporary walls in accordance with the plans and accepted submittals. If applicable, install foundations located in the reinforced zone before placing shoring backfill or reinforcement unless otherwise approved. Notify the Engineer when foundation excavation is complete. Do not place shoring backfill or reinforcement until excavation dimensions and foundation material are approved.

Erect welded wire facing so the wall position is as shown in the plans and accepted submittals. Set welded wire facing adjacent to each other in the horizontal and vertical direction to completely cover the wall face with facing. Stagger welded wire facing to create a running bond by centering facing over joints in the row below.

Attach geostrip reinforcement to welded wire facing and wrap geotextile reinforcement and retention geotextiles behind welded wire facing as shown in the plans and accepted submittals. Cover geotextiles with at least 3" of shoring backfill. Overlap adjacent geotextile reinforcement and retention and separation geotextiles at least 18 inches with seams oriented perpendicular to the wall face. Hold geotextiles in place with wire staples or anchor pins as needed.

Place reinforcement within 3 inches of locations shown in the plans and accepted submittals. Before placing shoring backfill, pull geosynthetic reinforcement taut so it is

in tension and free of kinks, folds, wrinkles or creases. Install reinforcement with the direction shown in the plans and accepted submittals. For temporary wire walls with separate reinforcement and facing components, attach welded wire grid or metallic strip reinforcement to welded wire facing as shown in the accepted submittals. Do not splice or overlap reinforcement so seams are parallel to the wall face. Contact the Engineer when unanticipated existing or future obstructions such as foundations, pavements, pipes, inlets or utilities will interfere with reinforcement.

Place shoring backfill in the reinforced zone in 8 to 10 inch thick lifts. Compact A-2-4 soil and Class II, Type 1 and Class III select material in accordance with Subarticle 235-3(C) of the *Standard Specifications*. Use only hand operated compaction equipment to compact backfill within 3 feet of welded wire facing. At a distance greater than 3 feet, compact shoring backfill with at least 4 passes of an 8 to 10 ton vibratory roller in a direction parallel to the wall face. Smooth wheeled or rubber tired rollers are also acceptable for compacting backfill. Do not use sheepsfoot, grid rollers or other types of compaction equipment with feet. Do not displace or damage reinforcement when placing and compacting shoring backfill. End dumping directly on geosynthetics is not permitted. Do not operate heavy equipment on reinforcement until it is covered with at least 8 inches of shoring backfill. Replace any damaged reinforcement to the satisfaction of the Engineer.

Backfill for temporary walls outside the reinforced zone in accordance with Article 410-8 of the *Standard Specifications*. Bench temporary walls into the sides of excavations where applicable. For temporary geosynthetic walls with top of wall within 5 feet of finished grade, remove top facing and incorporate top reinforcement layer into fill when placing fill in front of wall. Temporary walls remain in place permanently unless otherwise required.

Measurement and Payment

Temporary Shoring will be measured and paid in square feet. Temporary walls will be measured as the square feet of exposed wall face area. Cantilever, braced or anchored shoring will be measured as the square feet of exposed shoring face area with the shoring height equal to the difference between the top and bottom of shoring elevations. Define “top of shoring” as where the grade intersects the back of sheet piles or H-piles and timber lagging. Define “bottom of shoring” as where the grade intersects front of sheet piles or H-piles and timber lagging. No measurement will be made for any embedment, shoring extension above top of shoring or pavement thickness above temporary walls.

The contract unit price for *Temporary Shoring* will be full compensation for providing shoring designs, submittals and materials, excavating, backfilling, hauling and removing excavated materials and supplying all labor, tools, equipment and incidentals necessary to construct temporary shoring.

No payment will be made for temporary shoring not shown in the plans or required by the Engineer including shoring for OSHA reasons or the Contractor’s convenience. No value engineering proposals will be accepted based solely on revising or eliminating shoring locations shown in the plans or estimated quantities shown in the bid item sheets as a result of actual field

measurements or site conditions.

PCB will be measured and paid in accordance with Article 1170-4 of the *Standard Specifications*. No additional payment will be made for anchoring PCB for temporary shoring. Costs for anchoring PCB will be incidental to temporary shoring.

Temporary guardrail will be measured and paid for in accordance with Article 862-6 of the *Standard Specifications*.

Payment will be made under:

Pay Item	Pay Unit
Temporary Shoring	Square Foot

WORK ZONE INSTALLER:

(7-20-21)(Rev. 4-21-26)

1101

SP11 R04

Page 11-4, Article 1101-14 WORK ZONE INSTALLER, lines 25-26, delete the first sentence of the first paragraph and replace with the following:

When temporary traffic control consists of more than flagging operations, the Contractor shall provide the service of at least one qualified work zone installer during the setup, installation, and removal of temporary traffic control within the highway right of way.

TEMPORARY CRASH CUSHIONS:

(4-21-26)

1089, 1160

SP11 R06

Page 10-204, Subarticle 1089-8(A) General, lines 26-29, delete the third and fourth paragraph.

Page 10-204, Subarticle 1089-8(A) General, line 34, delete the last sentence of the fifth paragraph.

Page 11-14, Article 1160-2 MATERIALS, lines 32-35, delete the second and third sentence of the first paragraph.

Page 11-15, Article 1160-3 CONSTRUCTION METHODS, add the following after line 1:

Use a redirective, non-gating temporary crash cushion when adequate space for the lateral displacement of the crash cushion is not available or as required in the TMP.

Page 11-15, Article 1160-3 CONSTRUCTION METHODS, line 7, add the following to the second paragraph:

Temporary crash cushion shall not be placed on an unpaved surface.

CONES:

(3-19-24)

1135

SP11 R35

Revise the *Standard Specifications* as follows:

Page 11-11, Article 1135-3 CONSTRUCTION METHODS, lines 19-20, delete the third sentence of the first paragraph, "Do not use cones in the upstream taper of lane or shoulder closures for multi-lane roadways."

FLAGGERS:

(12-17-24)(Rev. 12-23-25)

1150

SP11 R50

Revise Section 1150 of the *Standard Specification* as follows:

Page 11-13, Article 1150-1, DESCRIPTION, add the following after line 31:

Alternatively, at the discretion of the Contractor, the Contractor may furnish, install, place in operation, repair, maintain, relocate, and remove remotely controlled Automated Flagging Assistance Devices (AFAD) or Temporary Portable Traffic Signal units (PTS units) to assist, supplement, or replace human flaggers for one-lane, two-way traffic maintenance during construction in accordance with this provision and the *Standard Specifications*.

For the purpose of this provision, an "approach" refers to a single lane of traffic moving in one direction toward a point of control or work zone. Flaggers, AFAD and PTS units are only used to control one lane of approaching traffic in a specific direction.

Page 11-13, Article 1150-2, MATERIALS, add the following after line 34:

Provide documentation to the Engineer that the AFAD or PTS units meets or exceeds the requirements of this special provision and is on the NCDOT APL or ITS and Signals QPL.

(A) Automated Flagging Assistance Devices (AFAD)**(1) AFAD General**

Cover the automated gate arm with Department approved Type VII, VIII or IX retroreflective sheeting of vertical alternating red and white stripes at 16 inch intervals measured horizontally. When the gate arm is in the down position the minimum vertical aspect of the arm and sheeting shall be 4 inches. The retroreflectorized sheeting shall be on both sides of the gate arm. With the AFAD parked or positioned 2 feet outside or in a location deemed acceptable for the lane being controlled, the gate arm shall reach at least to the center of the lane but shall not exceed the width of the lane being controlled.

Design the system to be fail-safe. Provide a conflict monitor, malfunction monitoring unit, or similar device that monitors for malfunctions and prevents the display of conflicting indications. This system shall be electronic and operated by remote control.

(2) AFAD Type I System: RED/YELLOW

Provide a Red/Yellow AFAD with at least one set of CIRCULAR RED and CIRCULAR YELLOW lenses in a vertical configuration that are 12 inches in diameter. The bottom of the housing (including brackets) shall be at least 7 feet (2.1 meters) above the pavement.

This system is required to have yellow 12 inch aluminum or polycarbonate vehicle signal heads with 10 inch tunnel visors, backplates, and Light Emitting Diode (LED) modules. Provide signal heads, backplates, and LED modules listed on the ITS and Signals QPL available on the Department's website.

Provide an automated gate arm on the AFAD that descends to a down position across the approaching lane of traffic when the steady CIRCULAR RED lens is illuminated and then ascends to an upright position when the flashing CIRCULAR YELLOW lens is illuminated. The automated gate arm is to be designed such that if a motorist pulls underneath the gate arm while lowering, no damage to the vehicle occurs.

A STOP HERE ON RED (R10-6 or R10-6a) sign shall be installed on the right-hand side of the approach at the point at which drivers are expected to stop when the steady CIRCULAR RED lens is illuminated.

To stop traffic, the AFAD shall transition from the flashing CIRCULAR YELLOW lens by initiating a minimum 5 second steadily illuminated CIRCULAR YELLOW lens followed by the CIRCULAR RED lens.

Once the CIRCULAR RED lens is displayed, the system is to have a minimum 2 second delay between the time the steady CIRCULAR RED is displayed and the time the gate arm begins to lower. The maximum delay between CIRCULAR RED and the time the gate arm lowers is 4 seconds. To permit stopped road users to proceed, the AFAD shall display the flashing CIRCULAR YELLOW lens and the gate arm shall be placed in the upright position.

Ensure the system monitors for a lack of yellow or red signal voltage, total loss of indication in any direction, presence of multiple indications on any approach and low power conditions.

Additional sets of CIRCULAR RED and CIRCULAR YELLOW lenses located over the roadway or on the left side of the approach and operated in unison with the primary set, may be used to improve visibility of the AFAD. If the set of lenses is located over any portion of the roadway that can be used by motor vehicles, the bottom of the housing (including brackets) shall be at least 15 feet (4.6 meters) above the pavement.

(3) AFAD Type II System: STOP/SLOW

Provide STOP/SLOW signs that are octagonal in shape, made of rigid material, and at least 36 inch x 36 inch in size. Letters shall be a minimum of 8 inches high. The STOP face shall have a red background with white letters and border.

The SLOW face shall be diamond shaped, orange, or yellow background with black letters and border. Cover both faces in a Department approved Type VII, VIII or IX

retroreflective sheeting. The minimum mounting height for the sign faces shall be 7 feet above the pavement to the bottom of the sign.

The AFAD's STOP/SLOW signs shall be supplemented with active conspicuity devices by incorporating a stop beacon (red lens) and a warning beacon (yellow lens). The stop beacon shall be no more than 24 inches above the STOP face. Mount the warning beacon no more than 24 inches above or beside of the SLOW face. Except for the mounting locations, the beacons shall conform to the provisions of Chapter 4L of the MUTCD and have 12 inch signal lenses.

Strobe/flashing lights are an acceptable alternative to flashing beacons. If utilized, they shall be either white or red flashing lights located within the STOP face and white or yellow flashing lights within the SLOW face and conform to the provisions of Chapter 6D of the MUTCD. If used, the lens diameter shall be a minimum of 5 inches with a minimum height of 6 inches. Equip strobes/flashing lights for both dual and quad flash patterns.

Type B warning lights shall not be used in lieu of the beacons or the strobe lights.

The faces of the AFADs STOP/SLOW sign may include louvers. If louvers are used, design the louvers such that the aspect of the sign face to approaching traffic is a full sign face at a distance of 50 feet or greater.

A WAIT ON STOP (R1-7) sign and a GO ON SLOW (R1-8) sign shall be displayed to traffic approaching the AFAD. Position signs on the same support structure as the AFAD. Both signs shall have black legends and borders on white Type III sheeting backgrounds. Each of these signs shall be rectangular in shape and be at least 24 inch x 30 inch size with letters at least 6 inches high.

Provide an automated gate arm on the AFAD that descends to a down position across the approaching lane of traffic when the STOP face is displayed and then ascends to an upright position when the SLOW face is displayed.

The automated gate arm is to be designed such that if a motorist pulls underneath the gate arm while lowering, no damage to the vehicle occurs.

A STOP HERE ON RED (R10-6 or R10-6a) sign shall be installed on the right-hand side of the approach at the point at which drivers are expected to stop when the STOP face is displayed.

When approaching motorists are to proceed, display the SLOW face and the warning beacon or strobes are to flash on the AFAD. When approaching motorists are will be stopped, display the STOP face and the stop beacon or strobes are to flash on the AFAD.

To stop traffic, the AFAD will transition from the SLOW face to the STOP face by initiating a minimum 5 second change cycle. First, the warning beacon is to steadily illuminated for the change cycle. If strobes are used in lieu of a warning beacon, they are to be placed in the quad flash pattern. At the end of the change

cycle, the STOP face is to be displayed with the stop beacon flashing and the warning beacon or strobes are to stop flashing. Once the STOP face is displayed, the system is to have a minimum 2 second delay between the time the STOP face is displayed and the time the gate arm begins to lower. The maximum delay between the time the STOP face is displayed and the time the gate arm lowers is 4 seconds.

To permit stopped road users to proceed, the gate arm shall be placed in the upright position and the AFAD shall display the SLOW face and the warning beacon or strobes are to flash in the dual flash pattern.

Do not flash the stop beacon when the SLOW face is displayed, and do not flash the warning beacon when the STOP face is displayed.

(B) Portable Traffic Signals (PTS) Units

Provide PTS units with at least one set of CIRCULAR RED, CIRCULAR YELLOW, and CIRCULAR GREEN lenses in a vertical configuration that are 12 inch diameter aluminum or polycarbonate vehicle signal heads with 10 inch tunnel visors, backplates, and Light Emitting Diode (LED) modules. All signal heads, tunnel visors, and backplates shall be yellow in color.

The bottom of the housing (including brackets) shall be at least 7 feet above the pavement for single set units. Additional signal heads on units with more than one signal head shall be capable of extending over the travel lane.

Communication Requirements

All PTS units within the signal set up systems shall maintain communication at all times by either hardwire cable or wireless radio link communication. If the hardwire cable communication is utilized the communication cable shall be deployed in a manner that will not intrude in the direct work area of the project or obstruct vehicular and pedestrian traffic. Utilize radio communication with 900MHz frequency band and frequency hopping capability. The radio link communication system shall have a minimum range of 1 mile.

Fault Mode Requirements

Revert PTS units to a flashing red mode upon system default unless otherwise specified by the Engineer. Equip the PTS units with a remote monitoring system. Where cell communication availability exists, the remote monitoring system shall adhere to the remote monitoring system section of this provision.

Remote Monitoring System

The remote monitoring system (RMS) shall be capable of reporting signal location, battery voltage / battery history and system default. Provide a password protected website viewable from any computer with internet capability for the RMS. In the event

of a system default, the RMS shall provide specific information concerning the cause of the system default (i.e. red lamp on signal number 1). Equip the RMS with a mechanism capable of immediately contacting a minimum of three previously designated individuals via text messaging and/or email upon a default.

The running program operating the PTS units shall be always available and viewable through the RMS website. Maintain a history of the RMS operating system in each signal including operating hours and events and the location of the PTS units.

Trailer / Cart

The AFAD and PTS units may be mounted on either a trailer or a moveable cart system.

Finish all exterior metal surfaces with Federal orange enamel per AMS-STD-595, color chip ID# 13538 or 12473 respectively with a minimum paint thickness of 2.5 mils (64 microns).

Design and test the AFAD or PTS units trailer / cart to withstand an 80 MPH wind load while in the operational position. Provide independent certification that the assembly meets the design wind load.

Equip the AFAD or PTS units with leveling jacks capable of stabilizing the unit in a horizontal position when located on slopes 6:1 or flatter.

Equip trailers in compliance with North Carolina Law governing motor vehicles and include a 12-volt trailer lighting system complying with *Federal Motor Carrier Safety Regulations 393*, safety chains and a minimum 2 inch ball hitch.

Provide a minimum 4 inch wide strip of fluorescent conspicuity sheeting retroreflective sheeting to the frame of the trailer. Apply the sheeting to all sides of the trailer. The sheeting shall meet the ASTM requirements of Type VII, VIII or IX.

Power System

Design the systems to operate both with and without an external power source. Furnish transmitters, generators, batteries, controls and all other components necessary to operate the device.

Provide equipment that is solar powered and supplemented with a battery backup system that includes a minimum 110/120 VAC powered on-board charging system capable of powering the unit for 7 continuous days with no solar power. Each unit shall also be capable of being powered by standard 110/120 VAC power sources, if applicable.

Locate batteries and electronic controls in a locked, weather and vandal resistant housings.

Page 11-14, Article 1150-3, CONSTRUCTION METHODS, add the following after line 11:

Flaggers shall have a path to escape an errant approaching vehicle at all times, unimpeded by barrier, guardrail, guiderail, parked vehicles, construction materials, slopes steeper than 2:1, or

any other obstruction at all times. If an unimpeded path cannot be maintained, the Contractor shall use AFAD or PTS units in lieu of a flagger.

Provide documentation to the Engineer prior to deploying the device that the AFAD or PTS units operator(s) are qualified flagger(s) that have been properly trained through an NCDOT approved training agency or other NCDOT approved training provider and that the qualified flagger(s) have received manufacturer training to operate that specific device. This training shall include proper installation, remote control operation, central control systems and maintenance of the AFAD or PTS units. The training shall take place off the project site where training conditions are removed from live traffic. The documentation shall include the names of the authorized trainer, the trainees, the device on which they have been trained and the date of the training. Provide updated documentation to the Engineer prior to deploying any additional operators.

Install advance warning signs and operate AFADs in accordance with the attached detail drawings in this provision.

Install advance warning signs and operate PTS units in accordance with *NCDOT Roadway Standard Drawings* No. 1101.02, Sheet 17.

AFAD and PTS units shall only be used in situations where there is only one lane of approaching traffic in the direction to be controlled. **At no time shall an AFAD unit controlling traffic through the work area be placed in an autonomous mode and/or left unattended.**

Signal timing and operation of PTS units shall be field verified and accepted by the Engineer before use.

Do not use AFAD or PTS units in locations where queueing from the AFAD or PTS units will extend to within 150 feet of a signalized intersection or railroad crossing. Do not use AFAD and PTS units as a substitute for or a replacement for a continuously operating temporary traffic control signal as described in Section 6F.84 of the MUTCD.

If used at night, illuminate each AFAD or PTS units as described in Section 6D of the MUTCD.

Provide a complete AFAD or PTS units that is capable of being relocated as traffic conditions demand.

If AFADs or PTS units become inoperative, be prepared at all times to replace the unit with the same type and model of AFAD or PTS units, revert to human flagging operations or terminate all construction activities requiring the use of the AFAD or PTS units until the AFAD or PTS units become operative or qualified human flaggers are available.

When the work requiring the AFAD or PTS units is not pursued for 30 minutes or longer, power off each AFAD or PTS units. Removed the AFAD or PTS units from the travel lane and relocated to a minimum of 5 feet from the edge line. AFAD gate arms shall be in the upright position. Remove all traffic control devices from the road, place two cones by each AFAD or PTS units and all signs associated with the lane closure operation shall be removed or laid down. At the end of each workday, remove all AFADs or PTS units from the roadway and shoulder areas.

Ensure the system's wireless communication links continuously monitor and verify proper transmission and reception of data used to monitor and control each AFAD or PTS units. Ensure ambient mobile or other radio transmissions or adverse weather conditions do not affect the system.

In the event of a loss of communications, immediately display the flashing RED or STOP indication on all AFAD or PTS units.

AFAD Specific Construction Methods

The flagger/operator controlling the AFAD units shall be on the project site at all times. If multiple AFAD units are used, one AFAD unit shall be the Main AFAD unit and all other units shall be remote AFAD units. Ensure that each device meets the physical display and operational characteristics as specified in the MUTCD.

Multiple AFAD units may be controlled with **one** flagger/operator when the AFAD units meet each of the following requirements:

- (1) AFAD units are spaced no greater than the manufacturer's recommendations.
- (2) Both AFAD units can be seen at the same time from the flagger/operator's position, or the AFAD is operating on its own secure network with malfunction detection and notification to the flagger/operator.
- (3) The flagger/operator has an unobstructed view of approaching traffic in both directions from the flagger/operator position or the AFAD is operating on its own secure network, with cameras that provide the flagger/operator an unobstructed view of approaching traffic from both directions. The flagger/operator may control the AFAD units from a pilot vehicle.

If any of the above requirements are not met, flagger/operator control each AFAD unit.

AFAD operators may either control traffic at side streets or driveways between the AFAD units or operate the pilot car while operating the AFAD system if approved by the Engineer. AFAD units must continue to be within clear sight of the operator during these work activities.

Page 11-14, Article 1150-4, MEASUREMENT AND PAYMENT, add the following after line 24:

Each AFAD or PTS unit will be measured and paid for as *Flaggers* paid by day in accordance with Article 1150-4 of the *Standard Specifications*. Where the pay item for *Flaggers* is not included in the original contract then no separate payment will be made for this item and payment will be included in the lump sum price bid for *Temporary Traffic Control* found elsewhere in this contract. Each approach controlled by AFAD or PTS units will be measured and paid as one flagger, irrespective of the number of devices used. If multiple PTS units are required to control a single approach, these units will collectively be considered as replacing one flagger.

No separate measurement or payment will be made for AFAD or PTS unit operators, as the cost of such including their training and operational costs shall be included in the unit or lump sum price for *Flaggers* or *Temporary Traffic Control*. Such price and payment also includes the relocation, maintenance, and removal during repair periods of AFAD or PTS units as well as the signal controller, communication, vehicle detection system, traffic signal software of PTS units and any other incidentals necessary to complete the work.

Red/Yellow Lens AFAD (TYPE I)

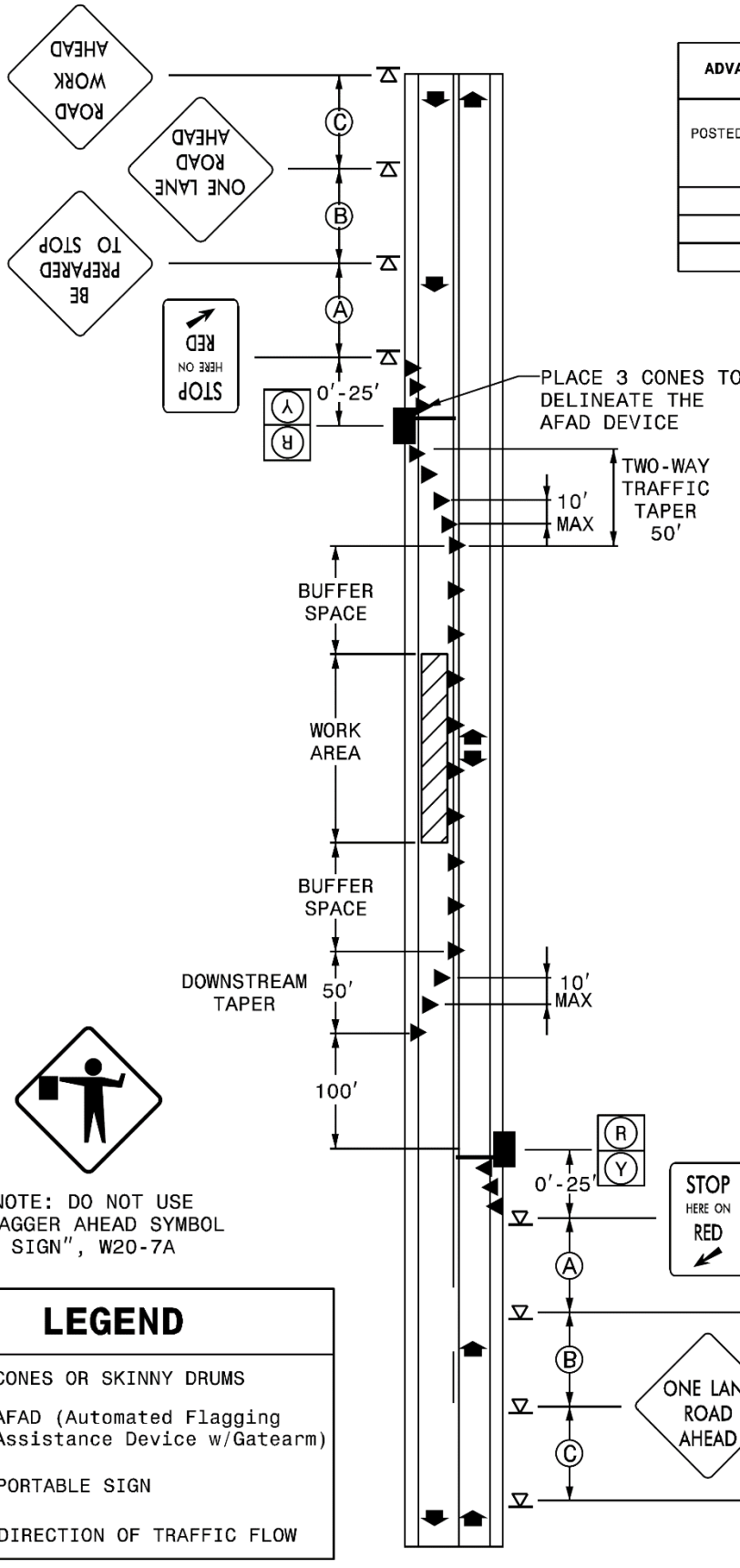

ADVANCE WARNING SIGN SPACING CHART			
POSTED SPEED LIMIT (MPH)	RECOMMENDED DISTANCE BETWEEN SIGNS FEET (+/-) SEE NOTE #1		
	(A)	(B)	(C)
≤ 35	200	200	200
40-50	350	350	350
55	500	500	500

DESIGN SPEED (MPH)	BUFFER SPACE (FEET)
30	85
35	120
40	155
45	195
50	240
55	290
60	345
65	405
70	470
75	540
80	615

NOTE: DO NOT USE "FLAGGER AHEAD SYMBOL SIGN", W20-7A

LEGEND

- CONES OR SKINNY DRUMS
- AFAD (Automated Flagging Assistance Device w/Gatearm)
- PORTABLE SIGN
- DIRECTION OF TRAFFIC FLOW

Stop/Slow AFAD (TYPE II)

ADVANCE WARNING SIGN SPACING CHART			
POSTED SPEED LIMIT (MPH)	RECOMMENDED DISTANCE BETWEEN SIGNS FEET (+/-) SEE NOTE #1		
	(A)	(B)	(C)
≤ 35	200	200	200
40-50	350	350	350
55	500	500	500

DESIGN SPEED (MPH)	BUFFER SPACE (FEET)
30	85
35	120
40	155
45	195
50	240
55	290
60	345
65	405
70	470
75	540
80	615

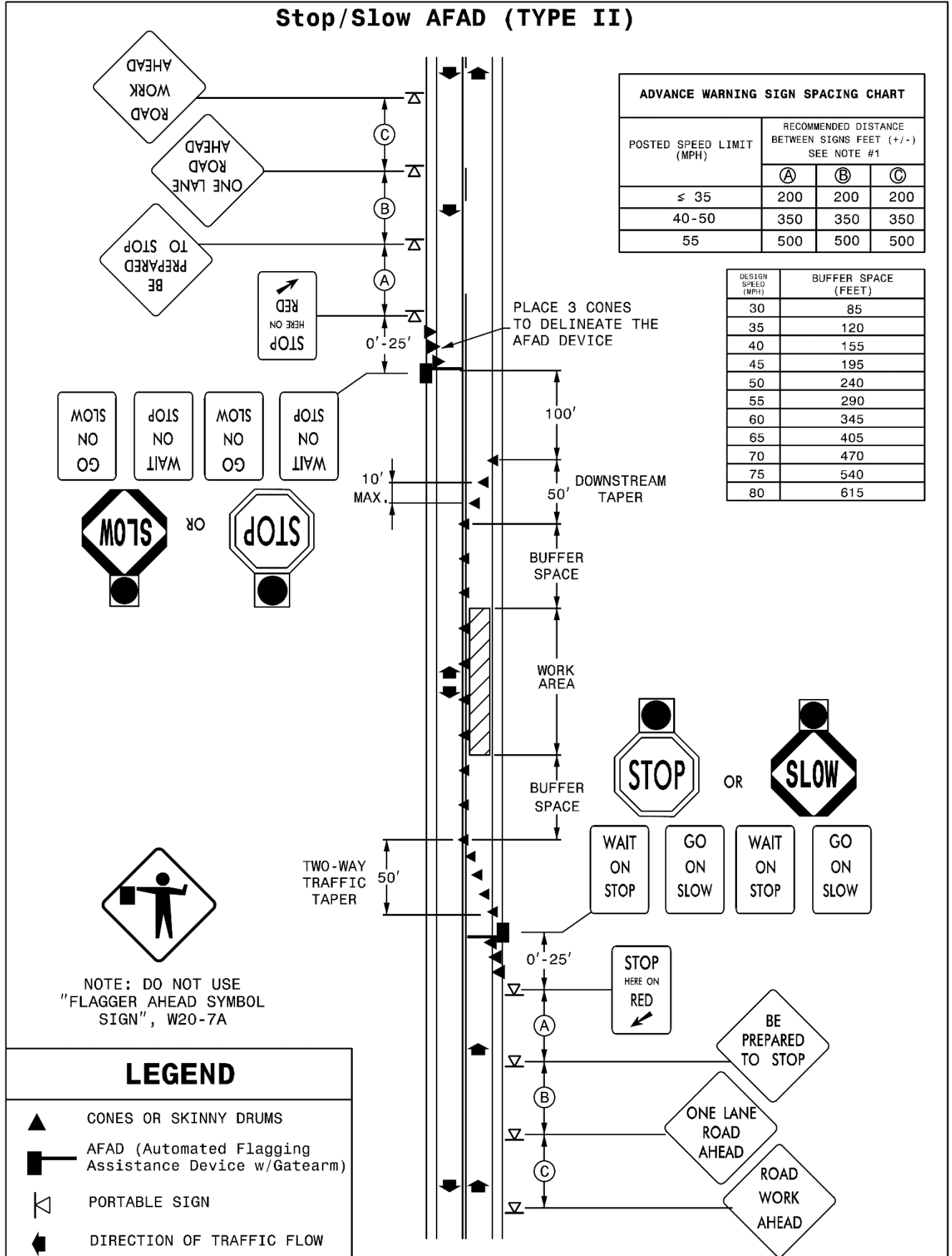

PORTABLE CONCRETE BARRIER:

(12-17-24)

1170

SP11 R70

Revise the *Standard Specifications* as follows:

Page 11-17, Subarticle 1170-3(A)(1) Portable Concrete Barrier, after line 25, add the following:

For MASH approved F-Shape K-Wall, install anchorage transitions between unanchored portable concrete barrier and temporary crash cushions, and between unanchored portable concrete barrier and portable concrete barrier (anchored) as shown in the *Roadway Standard Drawings*, No. 1170.01.

Page 11-19, Article 1170-4 MEASUREMENT AND PAYMENT, line 16, after the second sentence of the first paragraph add the following:

Crash cushion to unanchored concrete requires a transition

Page 11-19, Article 1170-4 MEASUREMENT AND PAYMENT, line 13, delete and replace “*Portable Concrete Barrier (____)*” with “*Portable Concrete Barrier*”.

Page 11-19, Article 1170-4 MEASUREMENT AND PAYMENT, line 16, after the second sentence of the first paragraph add the following:

As shown in the *Roadway Standard Drawings*, No. 1170.01, anchorage transition sections between *Portable Concrete Barrier* and *Temporary Crash Cushions* as found in Section 1160 will be measured and paid as *Portable Concrete Barrier*. No additional payment will be made for equipment, materials or labor to meet the anchorage transition requirements.

Page 11-19, Article 1170-4 MEASUREMENT AND PAYMENT, line 16, after the first paragraph add the following:

Portable Concrete Barrier (Anchored) will be measured and paid as the maximum number of linear feet furnished, satisfactorily installed, accepted by the Engineer, maintained and removed, at any one time during the life of the project, including anchorage transition sections between portable concrete barrier and portable concrete barrier (anchored) as shown in the *Roadway Standard Drawings*, No. 1170.01. Measurement will be made by counting the number of barrier units used and multiplying by the length of a unit.

Page 11-19, Article 1170-4 MEASUREMENT AND PAYMENT, line 21, delete and replace “*Remove and Reset Portable Concrete Barrier (____)*” with “*Remove and Reset Portable Concrete Barrier*”.

Page 11-19, Article 1170-4 MEASUREMENT AND PAYMENT, line 24, after the second sentence of the third paragraph add the following:

As shown in the *Roadway Standard Drawings*, No. 1170.01, anchorage transition sections between *Portable Concrete Barrier* and *Temporary Crash Cushions* as found in Section 1160 will be measured and paid as *Remove and Reset Portable Concrete Barrier*. No additional

payment will be made for equipment, materials or labor to meet the anchorage transition requirements.

Page 11-19, Article 1170-4 MEASUREMENT AND PAYMENT, line 28, after the third paragraph add the following:

Remove and Reset Portable Concrete Barrier (Anchored) will be measured and paid as the number of linear feet of barrier moved from one location on the project to another location on the project, including anchorage transition sections between portable concrete barrier and portable concrete barrier (anchored) as shown in the Roadway Standard Drawings, No. 1170.01. Measurement will be made by counting the number of barrier units moved during any one move and multiplying by the length of a unit. Where barrier units are moved more than once, each move will be measured separately. Whenever the Engineer directs the Contractor to move barrier units from an installed location to a stockpile either on or off the project and then back to another installed location, the complete move from the first installed location to the next installed location will be measured as 2 moves.

PAVEMENT MARKINGS:

(5-19-26)

1087, 1205

SP12 R04

Revise the *Standard Specifications* as follows:

Page 10-185, Subarticle 1087-2(A) Paint Composition, line 15, replace “TT--P-1952” with “TT--P-1952, Type III”.

Page 10-185, Subarticle 1087-2(C) Thermoplastic Composition, lines 28-33, replace the first through third paragraph and the table with the following:

(C) Thermoplastic and Integrated Multipolymer (IMP) Composition

Use thermoplastic alkyd/maleic pavement markings composed of the materials in Table 1087-1A and integrated multipolymer markings composed of the materials in Table 1087-1B.

TABLE 1087-1A PHYSICAL PROPERTIES OF THERMOPLASTIC PAVEMENT MARKINGS	
Component	By Weight
Alkyd/Maleic Binder	18.0% Min
Premixed Glass Beads (AASHTO M 247 – Type 3)	40.0% Min
Titanium Dioxide Pigment (ASTM D476 Type 2)	10.0% Min. (white) 1.5% Min. (yellow)

TABLE 1087-1B PHYSICAL PROPERTIES OF INTEGRATED MULTIPOLYMER (IMP) PAVEMENT MARKINGS	
Component	By Weight
Binder	21.0% Min

Premixed Glass Beads (AASHTO M 247 – Type 3)	40.0% Min
Titanium Dioxide Pigment (ASTM D476 Type 2)	10.0% Min. (white only)
Inert Filler	15% Max white / 24% Max Yellow

Use white material that does not contain anatase titanium dioxide pigment. Use yellow material that does not contain any intentionally added lead chromate.

Calcium carbonate and inert fillers may be used by the manufacturer, providing all other qualifications are met.

Page 10-185, Subarticle 1087-2(C) Thermoplastic Composition, line 34, replace “thermoplastic” with “material”.

Page 10-185, Subarticle 1087-2(C) Thermoplastic Composition, line 36, replace “alkyd/maleic binder” with “binder”.

Page 10-185, Subarticle 1087-2(C) Thermoplastic Composition, line 38, replace “maleic-modified glycerol of resin” with “rosin ester”.

Page 10-186, Subarticle 1087-2(C) Thermoplastic Composition, insert the following paragraph after line 2:

The integrated multipolymer binder shall consist of a mixture of modified rosin ester, polyamide and a copolymer (e.g. EVA) with waxes and/or plasticizers. At least 3% of the total formulation weight shall be 100% polyamide. The binder shall contain no petroleum hydrocarbon resins.

Page 10-186, Subarticle 1087-2(C) Thermoplastic Composition, lines 3, 6, 9 and 11, replace “thermoplastic material” with “material”.

Page 10-186, Article 1087-3 COLOR, after line 27, replace “Crystal: Color No. 17886 (White)” with “White: Color No. 17925”.

Page 10-186, Subarticle 1087-4(A) Composition, lines 31-34, replace the second paragraph with the following:

Manufacture the beads from 100% recycled or virgin non-pigmented glass from a composition designed to be highly resistant to traffic wear and to the effects of weathering. All intermix and drop-on glass beads shall be manufactured using 100% North American recycled glass cullet, virgin North American glass or a combination of the two.

Page 10-187, Subarticle 1087-4(C) Gradation & Roundness, lines 4-6, replace the first paragraph and table with the following:

Use drop-on and intermixed glass beads in all pavement markings with at least 80% true spheres when tested in accordance with ASTM D1155. Drop-on glass beads for permanent pavement markings shall be high performance glass beads listed on the NCDOT APL. If otherwise specified, or at the direction of the Engineer, other drop-on reflective media may be used on

permanent markings. Drop-on glass beads used on any interim or temporary pavement markings shall meet Table 1087-2.

TABLE 1087-2 GLASS BEAD GRADATION REQUIREMENTS		
Sieve Size	Gradation Requirements	
	Minimum	Maximum
Passing #20	95%	100%
Retained on #30	5%	20%
Retained on #50	40%	80%
Retained on #80	15%	50%
Passing #80	0%	10%
Retained on #200	0%	5%

Page 10-187, Article 1087-5 PACKAGING FOR SHIPMENT, line 31, replace “Thermoplastic pavement marking materials” with “Thermoplastic and integrated multipolymer pavement marking materials”.

Page 10-188, Subarticle 1087-7(B) Thermoplastic Pavement Marking Material Composition, line 17, replace “(B) Thermoplastic Pavement Marking Material Composition” with “(B) Thermoplastic and Integrated Multipolymer Pavement Marking Material Composition”.

Page 10-188, Subarticle 1087-7(C) Flash Point, line 22, replace “thermoplastic” with “thermoplastic and integrated multipolymer material”.

Page 10-188, Subarticle 1087-7(D) Requirements, line 25, replace “thermoplastic material” with “thermoplastic and integrated multipolymer material”.

Page 10-189, Subarticle 1087-7(D), after line 15, add the following:

(9) Tensile Elongation

The integrated multipolymer material shall have an elongation of at least 10% when tested in accordance with ASTM D638 (1"x 6", 0.25"/min).

(10) Abrasion Resistance

The integrated multipolymer material shall have no more than 0.40 g weight loss following taber abrasion with CS17 wheels for 1000 cycles with 1 kg weight per ASTM D4060.

Page 10-189, Article 1087-8 MATERIAL CERTIFICATION, lines 22-23, replace the third paragraph with the following:

Reflective media not covered in this, or other specifications must meet AASHTO M 247 Type 3 or 4 and a NCDOT Type 2 Material Certification must be provided.

Page 10-189, Article 1087-8 MATERIAL CERTIFICATION, after line 23, add the following to the table:

Integrated Multipolymer	Type 2 Material Certification and Type 3 Material Certification
-------------------------	---

Page 12-3, Subarticle 1205-3(F) Surface Preparation and Curing Compound Removal, line 8, add the following as a second sentence of the first paragraph:

Only apply markings to dry clean surfaces.

Page 12-4, Subarticle 1205-3(G)(1) General for all types of Pavement Markings, line 16, replace the first sentence of the eighth paragraph with the following:

Protect the pavement markings until they are track free before exposing them to traffic.

Page 12-4, Subarticle 1205-3(G)(1) General for all types of Pavement Markings, lines 22-24, delete the second sentence of the tenth paragraph.

Page 12-4, Subarticle 1205-3(G)(1) General for all types of Pavement Markings, after line 24, replace “White: Color No. 17886” with “White: Color No. 17295”.

Page 12-5, Subarticle 1205-3(I) Removal of Pavement Markings, line 32, add the following as the third sentence of the seventh paragraph:

Before applying integrated multipolymer (IMP) pavement markings over existing thermoplastic pavement markings, remove at least 85% of the oxidized existing thermoplastic.

Page 12-5, Subarticle 1205-3(I) Removal of Pavement Markings, line 35, replace “thermoplastic” with “thermoplastic or IMP”.

Page 12-6, Article 1205-4 THERMOPLASTIC, line 3, replace “1205-4 THERMOPLASTIC” with “1205-4 THERMOPLASTIC AND INTEGRATED MULTIPOLYMER (IMP)”.

Page 12-6, Subarticle 1205-4(A) Application Equipment, lines 7, 16, 20, 24, 25, 27 and 29, delete “thermoplastic”

Page 12-6, Subarticle 1205-4(B) Weather Limitations and Seasonal Limitations, line 38, replace “thermoplastic pavement markings” with “thermoplastic or integrated multipolymer pavement markings”.

Page 12-6, Subarticle 1205-4(B) Weather Limitations and Seasonal Limitations, line 42, delete “thermoplastic”.

Page 12-7, Subarticle 1205-4(C) Application, lines 2, 3, 10, 21 and 31, delete “thermoplastic”.

Page 12-7, Subarticle 1205-4(C) Application, after line 17, in Table 1205-2 MINIMUM REFLECTOMETER REQUIREMENTS FOR THERMOPLASTIC replace “Standard Glass

Beads” with “High Performance Glass Beads” and for the Reflectivity of White replace “375 mcd/lux/m²” with “425 mcd/lux/m²” and Yellow replace “250 mcd/lux/m²” with “325 mcd/lux/m²”

Page 12-7, Subarticle 1205-4(C) Application, line 23, replace “thermoplastic pavement marking” with “final pavement marking”.

Page 12-7, Subarticle 1205-4(C) Application, after line 32, replace “**TABLE 1205-3 THICKNESS REQUIREMENTS FOR THERMOPLASTIC**” with “**TABLE 1205-3 THICKNESS REQUIREMENTS FOR THERMOPLASTIC AND INTEGRATED MULTIPOLYMER**”.

Page 12-9, Subarticle 1205-5(C) Observation Period, before line 1, replace “375 mcd/lux/m²” with “425 mcd/lux/m²” and replace “250 mcd/lux/m²” with “325 mcd/lux/m²”.

Page 12-11, Subarticle 1205-8(C) Application, lines 17-20, replace the first paragraph with the following:

Final pavement marking application of paint shall be placed in 1 application of 30 mils wet each and consist of reflective media applied at a rate to immediately obtain the minimum retroreflective values.

Page 12-11, Subarticle 1205-8(C) Application, line 26, delete “15 mil”.

Page 12-11, Subarticle 1205-8(C) Application, after line 31, replace Table 1205-6 with the following:

TABLE 1205-6 REFLECTOMETER REQUIREMENTS FOR PAINT		
Item	Color	Reflectivity
Standard Glass Beads	White	225 mcd/lux/m ²
	Yellow	200 mcd/lux/m ²
High Performance Glass Beads	White	425 mcd/lux/m ²
	Yellow	325 mcd/lux/m ²

Page 12-12, Article 1205-10 MEASUREMENT AND PAYMENT, lines 5-7, delete the second sentence of the first paragraph.

Page 12-12, Article 1205-10 MEASUREMENT AND PAYMENT, lines 12-14, delete the second sentence of the second paragraph.

Page 12-12, Article 1205-10 MEASUREMENT AND PAYMENT, lines 17-19, delete the third sentence of the third paragraph.

Page 12-12, Article 1205-10 MEASUREMENT AND PAYMENT, lines 40-43, replace the second sentence of the ninth paragraph with the following:

No direct payment will be made for the work involved in applying the lines, including but not limited to surface preparation, reapplication of molten pavement marking crossed by a vehicle, removal of all pavement marking materials spilled on the roadway surface, and repair of markings tracked by a vehicle.

Page 12-13, Article 1205-10 MEASUREMENT AND PAYMENT, after line 12, add the following to the pay item and pay unit list:

Pay Item	Pay Unit
Integrated Multipolymer Pavement Marking Lines, __", __ mils	Linear Foot
Integrated Multipolymer Pavement Marking Symbols, __ mils	Each
Integrated Multipolymer Pavement Marking Characters, __ mils	Each

SNOWPLOWABLE DELINEATION:

(10-15-24)

1253

SP12 R53

Description

Furnish, install and maintain snowplowable delineation.

There are five snowplowable delineation alternate options approved for use in North Carolina. They include the following markers and markings options:

- (1) Polycarbonate H-shaped Markers
- (2) Inlaid Raised Pavement Markers
- (3) 10' Rumble Skips
- (4) Inlaid Cradle Markers
- (5) 10' Inlaid Pavement Markings

Only one type of snowplowable delineation will be allowed on a single project.

Materials

Refer to Division 10 of the *Standard Specifications*.

Item	Section
Epoxy	1081
Pavement Markings	1087
Snowplowable Pavement Markers	1086-3

Any snowplowable pavement delineation shall conform to the applicable requirements of Sections 1086, 1087, and 1081 of the *Standards and Specifications*. Use snowplowable delineation markers and markings listed on the NCDOT APL. Any treatment that requires pavement cutting or milling shall be installed within 7 calendar days of the pavement cutting or milling operation.

Construction Methods**(A) General**

For any snowplowable delineation, prior to installation, by brushing, blow cleaning, vacuuming or other suitable means, ensure that all materials and the pavement surface are free of dirt, grease, dust, oil, moisture, mud, grass, or any other material that would prevent adhesion to the pavement by brushing blow cleaning, or vacuuming. If required, apply a primer per manufactures recommendations to pavement surfaces before applying pavement marking material.

Install snowplowable delineation per manufacturers specifications every 80 feet. Make sure pavement markers are oriented to traffic correctly and pavement markings are applied in a uniform thickness. Do not apply markings over longitudinal joints. Protect the pavement markings until they are tack free. Apply applicable Sections 1205 and 1250 of the *Standards Specifications*.

If damage occurs during installation the effected treatments shall be corrected or replaced. This work shall be considered incidental to the installation of the marking or marker.

(B) Polycarbonate H-shaped Markers and Inlaid Cradle Markers

Bond marker housings to the pavement with epoxy adhesive. Mechanically mix and dispense epoxy adhesives as required by the manufacturer's specifications. Place the markers immediately after the adhesive has been mixed and dispensed.

Install polycarbonate H-shaped markers and inlaid cradle markers castings into slots sawcut into the pavement. Make slots in the pavement to exactly duplicate the shape of the casting of the polycarbonate H-shaped markers and inlaid cradle markers.

If saw cutting, milling, or grooving operations are used, promptly remove all resulting debris from the pavement surface. Install the marker housings within 7 calendar days after saw cutting , milling, or grooving the pavement. Remove and dispose of loose material from the slots by brushing, blow cleaning or vacuuming. Dry the slots before applying the epoxy adhesive. Install polycarbonate H-shaped markers and inlaid cradle markers according to the manufacturer's recommendations.

Protect the polycarbonate H-shaped markers or inlaid cradle markers until the epoxy has initially cured and is track free.

Construct inlaid cradle markers in accordance with the details in the plans and as directed by the Engineer.

(C) Reflector Replacement

The following requirements only apply to polycarbonate H-shaped markers and inlaid cradle markers.

In the event that a reflector is damaged, replace the damaged reflector by using adhesives and methods recommended by the manufacturer of the markers and approved by the Engineer. This work is considered incidental if damage occurs during the initial installation of the marker housings and maintenance of initial polycarbonate H-shaped markers or inlaid cradle markers specified in this section.

If during reflector replacement it is discovered that the housing is missing or broken this will be paid as *Polycarbonate H-shaped Markers* or *Inlaid Cradle Markers*. Missing housings shall be replaced. Broken housings shall be removed and replaced. In both cases the slot for the housings shall be properly prepared prior to installing the new housing; patch the existing marker slots as directed by the Engineer and install the new marker approximately one foot before or after the patch. Removal of broken housings and preparation of slots will be considered incidental to the work of replacing housings.

(D) Inlaid Raised Pavement Markers

Cut groove in accordance with the details in the plans and as directed by the Engineer.

Use adhesive recommended by the manufacturer to install markers into the groove in accordance with Section 1251. The raised pavement markers are incidental to inlaid raised pavement markers.

(E) 10' Rumble Skips

Construct 10' rumble skips on asphalt concrete in accordance with Section 665 for all centerline and shoulder rumble skips, details in the plans and as directed by the Engineer. Construct 10' rumble skips on Portland cement concrete in accordance with Section 730 for all centerline and shoulder rumble skips, details in the plans and as directed by the Engineer. The milled rumble strips are incidental to the rumble skips. Using polyurea or extruded 90 mil thermoplastic construct pavement markings in accordance with Section 1205.

(F) 10' Inlaid Pavement Markings

The groove in which the marking is to be placed shall be one inch wider than the marking to be placed and 10 mils deeper than the thickness of the marking.

When using this method, use enhanced reflective media. The following retroreflectivity values shall be met.

MINIMUM INITIAL REFLECTOMETER READINGS		
Item	Color	Reflectivity
Enhanced Reflectivity Media	White	450 mcd/lux/m ²
	Yellow	350 mcd/lux/m ²

Using polyurea, extruded 90 mil thermoplastic or cold applied plastic construct pavement markings in accordance with Section 1205.

Maintenance

Maintain all installed snowplowable delineation before acceptance by the Engineer.

Measurement and Payment

Polycarbonate H-shaped Markers will be measured and paid as the actual number of polycarbonate H-shaped markers satisfactorily placed and accepted by the Engineer.

Inlaid Raised Pavement Markers will be measured and paid as the actual number of inlaid raised pavement markers satisfactorily placed and accepted by the Engineer.

10' Rumble Skips will be measured and paid as the actual number of rumble skips satisfactorily placed and accepted by the Engineer.

Inlaid Cradle Markers will be measured and paid as the actual number of pavement markers satisfactorily placed and accepted by the Engineer.

10' Inlaid Pavement Markings will be measured and paid as the actual number of 10' inlaid pavement markings satisfactorily placed and accepted by the Engineer.

Replace Snowplowable Pavement Marker Reflector will be measured and paid in accordance with Article 1253-5.

Payment will be made under:

Pay Item	Pay Unit
Polycarbonate H-shaped Markers	Each
Inlaid Raised Pavement Markers	Each
10' Rumble Skips	Each
Inlaid Cradle Markers	Each
10' Inlaid Pavement Markings	Each

COIR FIBER MAT:

(9-16-25)

1629

SP16 R05

Page 16-9, Article 1629-2 MATERIALS, lines 22-24, delete and replace the last paragraph with the following:

Provide #3 or #4 uncoated reinforcing steel anchors, 24 inches in length, bent into a U-shape with a 4-inch diameter bend and a 4-inch straight leg extending from the bend to catch and secure the coir fiber mat.

WATTLE DEVICES:

(1-1-24)(Rev. 9-16-25)

1642

SP16 R10

Page 16-23, Subarticle 1642-2(B) Wattle, lines 10-12, delete and replace with the following:

(B) Wattle and Wattle Barrier

Wattles shall meet Table 1642-1.

TABLE 1642-1 100% CURLED WOOD (EXCELSIOR) FIBERS - WATTLE	
Property	Property Value
Minimum Diameter	12 inches
Minimum Density	2.5 pcf +/- 10%
Net Material	Synthetic
Net Openings	1 inch x 1 inch
Net Configuration	Totally Encased
Minimum Weight	20 lb +/- 10% per 10 foot length

Coir Fiber Wattles shall meet Table 1642-2.

TABLE 1642-2 100% COIR (COCONUT) FIBERS WATTLE	
Property	Property Value
Minimum Diameter	12 inches
Minimum Density	3.5 pcf +/- 10%
Net Material	Coir Fiber
Net Openings	2 inch x 2 inch
Net Strength	90 lb
Minimum Weight	2.6 pcf +/- 10%

Wattle Barriers shall meet Table 1642-3.

TABLE 1642-3	
100% CURLED WOOD (EXCELSIOR) FIBERS – WATTLE BARRIER	
Property	Property Value
Minimum Diameter	18 inches
Minimum Density	2.9 pcf +/- 10%
Net Material	Synthetic
Net Openings	1 inch x 1 inch
Net Configuration	Totally Encased
Minimum Weight	5 pcf +/- 10%

Coir Fiber Wattle Barriers shall meet Table 1642-4.

TABLE 1642-4	
100% COIR (COCONUT) FIBERS WATTLE BARRIER	
Property	Property Value
Minimum Diameter	18 inches
Minimum Density	5 pcf +/- 10%
Net Material	Coir Fiber
Net Openings	2 inch x 2 inch
Net Strength	90 lb
Minimum Weight	10 pcf +/- 10%

Pages 16-24 & 16-25, Article 1642-5 MEASUREMENT AND PAYMENT, lines 42-47 & lines 1-2, delete and replace with the following:

Wattle will be measured and paid for by the actual number of linear feet of wattles which are installed and accepted. Such price and payment will be full compensation for all work covered by this section, including, but not limited to, furnishing all materials, labor, equipment and incidentals necessary to install the *Wattle*.

Coir Fiber Wattles will be measured and paid for by the actual number of linear feet of coir fiber wattles which are installed and accepted. Such price and payment will be full compensation for all work covered by this section, including, but not limited to, furnishing all materials, labor, equipment and incidentals necessary to install the *Coir Fiber Wattles*.

Wattle Barrier will be measured and paid as the actual number of linear feet of wattle barrier installed and accepted. Such price and payment will be full compensation for all work covered by this provision, including, but not limited to, furnishing all materials, labor, equipment and incidentals necessary to install the *Wattle Barrier*.

Coir Fiber Wattle Barrier will be measured and paid as the actual number of linear feet of coir fiber wattle barrier installed and accepted. Such price and payment will be full compensation for all work covered by this provision, including, but not limited to, furnishing all materials, labor, equipment and incidentals necessary to install the *Coir Fiber Wattle Barrier*.

Page 16-25, Article 1642-5 MEASUREMENT AND PAYMENT, after line 9, delete and replace “ ___ Wattle Check” with “Wattle”.

Page 16-25, Article 1642-5 MEASUREMENT AND PAYMENT, after line 9, delete and replace “ ___ Wattle Barrier” with “Wattle Barrier”.

Page 16-25, Article 1642-5 MEASUREMENT AND PAYMENT, after line 9, add the following:

Pay Item	Pay Unit
Coir Fiber Wattle	Linear Foot
Coir Fiber Wattle Barrier	Linear Foot

STANDARD SPECIAL PROVISION**AVAILABILITY OF FUNDS – TERMINATION OF CONTRACTS**

(5-20-08)(Rev. 1-16-24)

Z-2

General Statute 143C-6-11. (h) Highway Appropriation is hereby incorporated verbatim in this contract as follows:

(h) Amounts Encumbered. – Transportation project appropriations may be encumbered in the amount of allotments made to the Department of Transportation by the Director for the estimated payments for transportation project contract work to be performed in the appropriation fiscal year. The allotments shall be multiyear allotments and shall be based on estimated revenues and shall be subject to the maximum contract authority contained in *General Statute 143C-6-11(c)*. Payment for transportation project work performed pursuant to contract in any fiscal year other than the current fiscal year is subject to appropriations by the General Assembly. Transportation project contracts shall contain a schedule of estimated completion progress, and any acceleration of this progress shall be subject to the approval of the Department of Transportation provided funds are available. The State reserves the right to terminate or suspend any transportation project contract, and any transportation project contract shall be so terminated or suspended if funds will not be available for payment of the work to be performed during that fiscal year pursuant to the contract. In the event of termination of any contract, the contractor shall be given a written notice of termination at least 60 days before completion of scheduled work for which funds are available. In the event of termination, the contractor shall be paid for the work already performed in accordance with the contract specifications.

Payment will be made on any contract terminated pursuant to the special provision in accordance with Subarticle 108-13(D) of the *Standard Specifications*.

STANDARD SPECIAL PROVISION
NCDOT GENERAL SEED SPECIFICATION FOR SEED QUALITY

(5-17-11)

Z-3

Seed shall be sampled and tested by the North Carolina Department of Agriculture and Consumer Services, Seed Testing Laboratory. When said samples are collected, the vendor shall supply an independent laboratory report for each lot to be tested. Results from seed so sampled shall be final. Seed not meeting the specifications shall be rejected by the Department of Transportation and shall not be delivered to North Carolina Department of Transportation warehouses. If seed has been delivered it shall be available for pickup and replacement at the supplier's expense.

Any re-labeling required by the North Carolina Department of Agriculture and Consumer Services, Seed Testing Laboratory, that would cause the label to reflect as otherwise specified herein shall be rejected by the North Carolina Department of Transportation.

Seed shall be free from seeds of the noxious weeds Johnsongrass, Balloonvine, Jimsonweed, Witchweed, Itchgrass, Serrated Tussock, Showy Crotalaria, Smooth Crotalaria, Sicklepod, Sandbur, Wild Onion, and Wild Garlic. Seed shall not be labeled with the above weed species on the seed analysis label. Tolerances as applied by the Association of Official Seed Analysts will NOT be allowed for the above noxious weeds except for Wild Onion and Wild Garlic.

Tolerances established by the Association of Official Seed Analysts will generally be recognized. However, for the purpose of figuring pure live seed, the found pure seed and found germination percentages as reported by the North Carolina Department of Agriculture and Consumer Services, Seed Testing Laboratory will be used. Allowances, as established by the NCDOT, will be recognized for minimum pure live seed as listed on the following pages.

The specifications for restricted noxious weed seed refers to the number per pound as follows:

<u>Restricted Noxious Weed</u>	<u>Limitations per Lb. Of Seed</u>	<u>Restricted Noxious Weed</u>	<u>Limitations per Lb. of Seed</u>
Blessed Thistle	4 seeds	Cornflower (Ragged Robin)	27 seeds
Cocklebur	4 seeds	Texas Panicum	27 seeds
Spurred Anoda	4 seeds	Bracted Plantain	54 seeds
Velvetleaf	4 seeds	Buckhorn Plantain	54 seeds
Morning-glory	8 seeds	Broadleaf Dock	54 seeds
Corn Cockle	10 seeds	Curly Dock	54 seeds
Wild Radish	12 seeds	Dodder	54 seeds
Purple Nutsedge	27 seeds	Giant Foxtail	54 seeds
Yellow Nutsedge	27 seeds	Horsenettle	54 seeds
Canada Thistle	27 seeds	Quackgrass	54 seeds
Field Bindweed	27 seeds	Wild Mustard	54 seeds
Hedge Bindweed	27 seeds		

Seed of Pensacola Bahiagrass shall not contain more than 7% inert matter, Kentucky Bluegrass, Centipede and Fine or Hard Fescue shall not contain more than 5% inert matter whereas a maximum of 2% inert matter will be allowed on all other kinds of seed. In addition, all seed

shall not contain more than 2% other crop seed nor more than 1% total weed seed. The germination rate as tested by the North Carolina Department of Agriculture shall not fall below 70%, which includes both dormant and hard seed. Seed shall be labeled with not more than 7%, 5% or 2% inert matter (according to above specifications), 2% other crop seed and 1% total weed seed.

Exceptions may be made for minimum pure live seed allowances when cases of seed variety shortages are verified. Pure live seed percentages will be applied in a verified shortage situation. Those purchase orders of deficient seed lots will be credited with the percentage that the seed is deficient.

FURTHER SPECIFICATIONS FOR EACH SEED GROUP ARE GIVEN BELOW:

Minimum 85% pure live seed; maximum 1% total weed seed; maximum 2% total other crop seed; maximum 144 restricted noxious weed seed per pound. Seed less than 83% pure live seed will not be approved.

Sericea Lespedeza
Oats (seeds)

Minimum 80% pure live seed; maximum 1% total weed seed; maximum 2% total other crop; maximum 144 restricted noxious weed seed per pound. Seed less than 78% pure live seed will not be approved.

Tall Fescue (all approved varieties)	Bermudagrass
Kobe Lespedeza	Browntop Millet
Korean Lespedeza	German Millet – Strain R
Weeping Lovegrass	Clover – Red/White/Crimson
Carpetgrass	

Minimum 78% pure live seed; maximum 1% total weed seed; maximum 2% total other crop seed; maximum 144 restricted noxious weed seed per pound. Seed less than 76% pure live seed will not be approved.

Common or Sweet Sundangrass

Minimum 76% pure live seed; maximum 1% total weed seed; maximum 2% total other crop seed; maximum 144 restricted noxious weed seed per pound. Seed less than 74% pure live seed will not be approved.

Rye (grain; all varieties)
Kentucky Bluegrass (all approved varieties)
Hard Fescue (all approved varieties)
Shrub (bicolor) Lespedeza

Minimum 70% pure live seed; maximum 1% total weed seed; maximum 2% total other crop seed; maximum 144 noxious weed seed per pound. Seed less than 70% pure live seed will not be approved.

Centipedegrass	Japanese Millet
Crownvetch	Reed Canary Grass
Pensacola Bahiagrass	Zoysia

Creeping Red Fescue

Minimum 70% pure live seed; maximum 1% total weed seed; maximum 2% total other crop seed; maximum 5% inert matter; maximum 144 restricted noxious weed seed per pound.

Barnyard Grass
Big Bluestem
Little Bluestem
Bristly Locust
Birdsfoot Trefoil
Indiangrass
Orchardgrass
Switchgrass
Yellow Blossom Sweet Clover

STANDARD SPECIAL PROVISION
ERRATA

(1-16-24)(Rev. 5-19-26)

Z-4

Revise the *2024 Standard Specifications* as follows:

Division 1

Page 1-1, Article 101-2 ABBREVIATIONS, line 25, replace "American Wood-Preservers' Association" with "American Wood Protection Association".

Page 1-18, Article 102-10 BID BOND OR BID DEPOSIT, line 26, replace " Subarticle 102-8(A)(8)(b)" with "Subarticle 102-8(A)(12)(b)".

Page 1-36, Subarticle 104-12(B) Evaluation of Proposals, line 21, replace "Design-Build Unit" with "Alternative Delivery Unit".

Page 1-36, Subarticle 104-12(D) Preliminary Review, line 37, replace "Design-Build Unit" with "Alternative Delivery Unit".

Page 1-37, Subarticle 104-12(E) Final Proposal, line 3, replace "Design-Build Unit" with "Alternative Delivery Unit".

Page 1-37, Subarticle 104-12(F) Design-Build VEPs, line 36, replace "Design-Build Unit" with "Alternative Delivery Unit".

Page 1-38, Subarticle 104-12(G) Modifications, line 1, replace "Design-Build Unit" with "Alternative Delivery Unit".

Division 3

Page 3-5, Article 305-2 MATERIALS, after line 16, replace " 1032-3(A)(7)" with "1032-3" and add the item "Galvanized Corrugated Steel Pipe" with Section "1032-3".

Page 3-6, Article 310-2 MATERIALS, after line 9, add the item "Galvanized Corrugated Steel Pipe" with Section "1032-3".

Division 6

Page 6-15, Article 610-1 DESCRIPTION, line 20, replace "The work includes" with "The work includes, but is not limited to,".

Page 6-15, Article 610-1 DESCRIPTION, line 22, replace "applying the tack coat as specified." with "applying the tack coat in accordance with Section 605.".

Page 6-30, Article 610-14 DENSITY ACCEPTANCE, line 39, replace "QC process." with "QC process in accordance with Section 609.".

Page 6-31, Article 610-16 MEASUREMENT AND PAYMENT, line 13, replace "*Hot Mix Asphalt Pavement*" with "*Asphalt Concrete _____ Course, Type _____*".

Page 6-50, Subarticle 661-4(A) Equipment, lines 4-7, replace the first two sentences of the seventh paragraph with the following:

When an erected fixed stringline is utilized for longitudinal profile and cross slope control furnish and erect the necessary guide line for the equipment.

Division 7

Page 7-18, Subarticle 710-10(A) General, lines 7-8, delete "for *Surface Testing Concrete Pavement*" from the last paragraph.

Division 8

Page 8-27, Article 846-1 DESCRIPTION, line 8, delete "4 inch" from the first paragraph.

Division 9

Page 9-17, Article 904-4 MEASUREMENT AND PAYMENT, prior to line 1, replace " Sign Erection, Relocate Type (Ground Mounted)" with "Sign Erection, Relocate Type ____ (Ground Mounted)".

Division 10

Page 10-51, Article 1024-4 WATER, prior to line 1, delete the "unpopulated blank row" in Table 1024-2 between "Time of set, deviation from control" and "Chloride Ion Content, Max.".

Page 10-170, Subarticle 1081-1(C) Requirements, line 4, replace "maximum" with "minimum".

Division 11

Page 11-15, Article 1160-4 MEASUREMENT AND PAYMENT, line 24, replace "Where barrier units are moved more than one" with "Where barrier units are moved more than once".

Division 15

Page 15-10, Article 1515-4 MEASUREMENT AND PAYMENT, lines 11, replace " All piping" with "All labor, the manhole, other materials, excavation, backfilling, piping".

Division 16

Page 16-14, Article 1633-5 MEASUREMENT AND PAYMENT, line 20-24 and prior to line 25, delete and replace with the following " *Flocculant* will be measured and paid in accordance with Article 1642-5 applied to the temporary rock silt checks."

Page 16-3, Article 1609-2 MATERIALS, after line 26, replace "Type 4" with "Type 4a".

Page 16-25, Article 1644-2 MATERIALS, after line 22, replace "Type 4" with "Type 4a".

Page 16-27, Article 1644-5 MEASUREMENT AND PAYMENT, line 31, replace "Article 1630-4" with "Article 1630-3".

Division 17

Page 17-15, Article 1715-4 MEASUREMENT AND PAYMENT, line 23, delete and replace "1.25" with "1-1/4".

Page 17-15, Article 1715-4 MEASUREMENT AND PAYMENT, line 24, delete and replace "(1.25" with " , 1-1/4".

STANDARD SPECIAL PROVISION**PLANT AND PEST QUARANTINES**

(Imported Fire Ant, Guava Root Knot Nematode, Spongy Moth (formerly known as gypsy moth), Witchweed, Cogon Grass, And Any Other Regulated Noxious Weed or Plant Pest)

(3-18-03)(Rev. 3-18-25)

Z-04a

Within Quarantined Area

This project may be within a county regulated for plant and/or pests. If the project or any part of the Contractor's operations is located within a quarantined area, thoroughly clean all equipment prior to moving out of the quarantined area. Comply with federal/state regulations by obtaining a certificate or limited permit for any regulated article moving from the quarantined area.

Originating in a Quarantined County

Obtain a certificate or limited permit issued by the N.C. Department of Agriculture/United States Department of Agriculture. Have the certificate or limited permit accompany the article when it arrives at the project site.

Contact

Contact the N.C. Department of Agriculture/United States Department of Agriculture at 1-800-206-9333, 919-707-3730, or <https://www.ncagr.gov/divisions/plant-industry/plant-protection/plant-industry-plant-pest-quarantines> to determine those specific project sites located in the quarantined area or for any regulated article used on this project originating in a quarantined county.

Regulated Articles Include

1. Soil, sand, gravel, compost, peat, humus, muck, and decomposed manure, separately or with other articles. This includes movement of articles listed above that may be associated with cut/waste, ditch pulling, and shoulder cutting.
2. Plants with roots including grass sod.
3. Plant crowns and roots.
4. Bulbs, corms, rhizomes, and tubers of ornamental plants.
5. Hay, straw, fodder, and plant litter of any kind.
6. Clearing and grubbing debris.
7. Used agricultural cultivating and harvesting equipment.
8. Used earth-moving equipment.
9. Any other products, articles, or means of conveyance of any character, if determined by an inspector present a hazard of spreading imported fire ant, guava root knot nematode, spongy moth (formerly known as gypsy moth), witchweed, cogon grass, or other regulated noxious weed or plant pest.

STANDARD SPECIAL PROVISION**MINIMUM WAGES**

(7-21-09)

Z-5

FEDERAL: The Fair Labor Standards Act provides that with certain exceptions every employer shall pay wages at the rate of not less than SEVEN DOLLARS AND TWENTY FIVE CENTS (\$7.25) per hour.

STATE: The North Carolina Minimum Wage Act provides that every employer shall pay to each of his employees, wages at a rate of not less than SEVEN DOLLARS AND TWENTY FIVE CENTS (\$7.25) per hour.

The minimum wage paid to all skilled labor employed on this contract shall be SEVEN DOLLARS AND TWENTY FIVE CENTS (\$7.25) per hour.

The minimum wage paid to all intermediate labor employed on this contract shall be SEVEN DOLLARS AND TWENTY FIVE CENTS (\$7.25) per hour.

The minimum wage paid to all unskilled labor on this contract shall be SEVEN DOLLARS AND TWENTY FIVE CENTS (\$7.25) per hour.

This determination of the intent of the application of this act to the contract on this project is the responsibility of the Contractor.

The Contractor shall have no claim against the Department of Transportation for any changes in the minimum wage laws, Federal or State. It is the responsibility of the Contractor to keep fully informed of all Federal and State Laws affecting his contract.

STANDARD SPECIAL PROVISION**TITLE VI AND NONDISCRIMINATION:**

(6-28-77)(Rev 1/16/2024)

Z-6

The North Carolina Department of Transportation is committed to carrying out the U.S. Department of Transportation's policy of ensuring nondiscrimination in the award and administration of contracts.

The provisions of this section related to United States Department of Transportation (US DOT) Order 1050.2A, Title 49 Code of Federal Regulations (CFR) part 21, 23 United States Code (U.S.C.) 140 and 23 CFR part 200 (or 49 CFR 303, 49 U.S.C. 5332 or 49 U.S.C. 47123) are applicable to all North Carolina Department of Transportation (NCDOT) contracts and to all related subcontracts, material supply, engineering, architectural and other service contracts, regardless of dollar amount. Any Federal provision that is specifically required not specifically set forth is hereby incorporated by reference.

(1) Title VI Assurances (USDOT Order 1050.2A, Appendix A)

During the performance of this contract, the contractor, for itself, its assignees, and successors in interest (hereinafter referred to as the "contractor") agrees as follows:

(a) Compliance with Regulations

The contractor (hereinafter includes consultants) shall comply with the Acts and the Regulations relative to Nondiscrimination in Federally-assisted programs of the U.S. Department of Transportation, Federal Highway Administration (FHWA), as they may be amended from time to time, which are herein incorporated by reference and made a part of this contract.

(b) Nondiscrimination

The contractor, with regard to the work performed by it during the contract, shall not discriminate on the grounds of race, color, or national origin in the selection and retention of subcontractors, including procurements of materials and leases of equipment. The contractor shall not participate directly or indirectly in the discrimination prohibited by the Acts and the Regulations, including employment practices when the contract covers any activity, project, or program set forth in Appendix B of 49 CFR Part 21.

(c) Solicitations for Subcontractors, Including Procurements of Materials and Equipment

In all solicitations, either by competitive bidding, or negotiation made by the contractor for work to be performed under a subcontract, including procurements of materials, or leases of equipment, each potential subcontractor or supplier shall be notified by the contractor of the contractor's obligations under this contract and the Acts and the Regulations relative to Nondiscrimination on the grounds of race, color, or national origin.

(d) Information and Reports

The contractor shall provide all information and reports required by the Acts, the Regulations, and directives issued pursuant thereto and shall permit access to its

books, records, accounts, other sources of information, and its facilities as may be determined by the Recipient or the FHWA to be pertinent to ascertain compliance with such Acts, Regulations, and instructions. Where any information required of a contractor is in the exclusive possession of another who fails or refuses to furnish the information, the contractor shall so certify to the Recipient or the FHWA, as appropriate, and shall set forth what efforts it has made to obtain the information.

(e) Sanctions for Noncompliance:

In the event of a contractor's noncompliance with the Non-discrimination provisions of this contract, the Recipient will impose such contract sanctions as it and/or the FHWA may determine to be appropriate, including, but not limited to:

- (i) Withholding payments to the contractor under the contract until the contractor complies; and/or
- (ii) Cancelling, terminating, or suspending a contract, in whole or in part.

(f) Incorporation of Provisions

The contractor shall include the provisions of paragraphs (a) through (f) in every subcontract, including procurements of materials and leases of equipment, unless exempt by the Acts, the Regulations and directives issued pursuant thereto. The contractor shall take action with respect to any subcontract or procurement as the Recipient or the FHWA may direct as a means of enforcing such provisions including sanctions for noncompliance. Provided, that if the contractor becomes involved in, or is threatened with litigation by a subcontractor, or supplier because of such direction, the contractor may request the Recipient to enter into any litigation to protect the interests of the Recipient. In addition, the contractor may request the United States to enter into the litigation to protect the interests of the United States.

(2) Title VI Nondiscrimination Program (23 CFR 200.5(p))

The North Carolina Department of Transportation (NCDOT) has assured the USDOT that, as a condition to receiving federal financial assistance, NCDOT will comply with Title VI of the Civil Rights Act of 1964 and all requirements imposed by Title 49 CFR part 21 and related nondiscrimination authorities to ensure that no person shall, on the ground of race, color, national origin, limited English proficiency, sex, age, or disability (including religion/creed or income-level, where applicable), be excluded from participation in, be denied the benefits of, or be subjected to discrimination under any programs, activities, or services conducted or funded by NCDOT. Contractors and other organizations under contract or agreement with NCDOT must also comply with Title VI and related authorities, therefore:

- (a) During the performance of this contract or agreement, contractors (e.g., subcontractors, consultants, vendors, prime contractors) are responsible for complying with NCDOT's Title VI Program. Contractors are not required to prepare or submit Title VI Programs. To comply with this section, the prime contractor shall:
 1. Post NCDOT's Notice of Nondiscrimination and the Contractor's own Equal Employment Opportunity (EEO) Policy in conspicuous locations accessible to all employees, applicants and subcontractors on the jobsite.

2. Physically incorporate the required Title VI clauses into all subcontracts on federally-assisted and state-funded NCDOT projects, and ensure inclusion by subcontractors into all lower-tier subcontracts.
 3. Required Solicitation Language. The Contractor shall include the following notification in all solicitations for bids and requests for work or material, regardless of funding source:

“The North Carolina Department of Transportation, in accordance with the provisions of Title VI of the Civil Rights Act of 1964 (78 Stat. 252, 42 U.S.C. §§ 2000d to 2000d-4) and the Regulations, hereby notifies all bidders that it will affirmatively ensure that any contract entered into pursuant to this advertisement, disadvantaged business enterprises will be afforded full and fair opportunity to submit bids in response to this invitation and will not be discriminated against on the grounds of race, color, or national origin in consideration for an award. In accordance with other related nondiscrimination authorities, bidders and contractors will also not be discriminated against on the grounds of sex, age, disability, low-income level, creed/religion, or limited English proficiency in consideration for an award.”
 4. Physically incorporate the FHWA-1273, in its entirety, into all subcontracts and subsequent lower tier subcontracts on Federal-aid highway construction contracts only.
 5. Provide language assistance services (i.e., written translation and oral interpretation), free of charge, to LEP employees and applicants. Contact NCDOT OCR for further assistance, if needed.
 6. For assistance with these Title VI requirements, contact the NCDOT Title VI Nondiscrimination Program at 1-800-522-0453.
- (b) Subrecipients (e.g. cities, counties, LGAs, planning organizations) may be required to prepare and submit a Title VI Plan to NCDOT, including Title VI Assurances and/or agreements. Subrecipients must also ensure compliance by their contractors and subrecipients with Title VI. (23 CFR 200.9(b)(7))
 - (c) If reviewed or investigated by NCDOT, the contractor or subrecipient agrees to take affirmative action to correct any deficiencies found within a reasonable time period, not to exceed 90 calendar days, unless additional time is granted by NCDOT. (23 CFR 200.9(b)(15))
 - (d) The Contractor is responsible for notifying subcontractors of NCDOT’s External Discrimination Complaints Process.
 1. Applicability

Title VI and related laws protect participants and beneficiaries (e.g., members of the public and contractors) from discrimination by NCDOT employees, subrecipients and contractors, regardless of funding source.

2. Eligibility

Any person—or class of persons—who believes he/she has been subjected to discrimination based on race, color, national origin, Limited English Proficiency (LEP), sex, age, or disability (and religion in the context of employment, aviation, or transit) may file a written complaint. The law also prohibits intimidation or retaliation of any sort.

3. Time Limits and Filing Options

Complaints may be filed by the affected individual(s) or a representative and must be filed no later than 180 calendar days after the following:

- (i) The date of the alleged act of discrimination; or
- (ii) The date when the person(s) became aware of the alleged discrimination; or
- (iii) Where there has been a continuing course of conduct, the date on which that conduct was discontinued or the latest instance of the conduct.

Title VI and related discrimination complaints may be submitted to the following entities:

- North Carolina Department of Transportation, Office of Civil Rights, Title VI Program, 1511 Mail Service Center, Raleigh, NC 27699-1511; toll free 1-800-522-0453
- Federal Highway Administration, North Carolina Division Office, 310 New Bern Avenue, Suite 410, Raleigh, NC 27601, 919-747-7010
- US Department of Transportation, Departmental Office of Civil Rights, External Civil Rights Programs Division, 1200 New Jersey Avenue, SE, Washington, DC 20590; 202-366-4070

4. Format for Complaints

Complaints must be in writing and signed by the complainant(s) or a representative, and include the complainant's name, address, and telephone number. Complaints received by fax or e-mail will be acknowledged and processed. Allegations received by telephone will be reduced to writing and provided to the complainant for confirmation or revision before processing. Complaints will be accepted in other languages, including Braille.

5. Discrimination Complaint Form

Contact NCDOT Civil Rights to receive a full copy of the Discrimination Complaint Form and procedures.

6. Complaint Basis

Allegations must be based on issues involving race, color, national origin (LEP), sex, age, disability, or religion (in the context of employment, aviation or transit). "Basis" refers to the complainant's membership in a protected group category.

TABLE 103-1 COMPLAINT BASIS			
Protected Categories	Definition	Examples	Applicable Nondiscrimination Authorities
Race and Ethnicity	An individual belonging to one of the accepted racial groups; or the perception, based usually on physical characteristics that a person is a member of a racial group	Black/African American, Hispanic/Latino, Asian, American Indian/Alaska Native, Native Hawaiian/Pacific Islander, White	Title VI of the Civil Rights Act of 1964; 49 CFR Part 21; 23 CFR 200; 49 U.S.C. 5332(b); 49 U.S.C. 47123. (<i>Executive Order 13166</i>)
Color	Color of skin, including shade of skin within a racial group	Black, White, brown, yellow, etc.	
National Origin (<i>Limited English Proficiency</i>)	Place of birth. Citizenship is not a factor. (<i>Discrimination based on language or a person's accent is also covered</i>)	Mexican, Cuban, Japanese, Vietnamese, Chinese	
Sex	Gender. The sex of an individual. <i>Note: Sex under this program does not include sexual orientation.</i>	Women and Men	1973 Federal-Aid Highway Act; 49 U.S.C. 5332(b); 49 U.S.C. 47123.
Age	Persons of any age	21-year-old person	Age Discrimination Act of 1975 49 U.S.C. 5332(b); 49 U.S.C. 47123.
Disability	Physical or mental impairment, permanent or temporary, or perceived.	Blind, alcoholic, para-amputee, epileptic, diabetic, arthritic	Section 504 of the Rehabilitation Act of 1973; Americans with Disabilities Act of 1990
Religion (in the context of employment) (<i>Religion/ Creed in all aspects of any aviation or transit-related construction</i>)	An individual belonging to a religious group; or the perception, based on distinguishable characteristics that a person is a member of a religious group. In practice, actions taken as a result of the moral and ethical beliefs as to what is right and wrong, which are sincerely held with the strength of traditional religious views. <i>Note: Does not have to be associated with a recognized religious group or church; if an individual sincerely holds to the belief, it is a protected religious practice.</i>	Muslim, Christian, Sikh, Hindu, etc.	Title VII of the Civil Rights Act of 1964; 23 CFR 230; FHWA-1273 Required Contract Provisions. (<i>49 U.S.C. 5332(b); 49 U.S.C. 47123</i>)

(3) Pertinent Nondiscrimination Authorities

During the performance of this contract, the contractor, for itself, its assignees, and successors in interest agrees to comply with the following non-discrimination statutes and authorities, including, but not limited to:

- (a) Title VI of the Civil Rights Act of 1964 (42 U.S.C. § 2000d et seq., 78 stat. 252), (prohibits discrimination on the basis of race, color, national origin); and 49 CFR Part 21.

- (b) The Uniform Relocation Assistance and Real Property Acquisition Policies Act of 1970, (42 U.S.C. § 4601), (prohibits unfair treatment of persons displaced or whose property has been acquired because of Federal or Federal-aid programs and projects);
- (c) Federal-Aid Highway Act of 1973, (23 U.S.C. § 324 et seq.), (prohibits discrimination on the basis of sex);
- (d) Section 504 of the Rehabilitation Act of 1973, (29 U.S.C. § 794 et seq.), as amended, (prohibits discrimination on the basis of disability) and 49 CFR Part 27;
- (e) The Age Discrimination Act of 1975, as amended, (42 U.S.C. § 6101 et seq.), (prohibits discrimination on the basis of age);
- (f) Airport and Airway Improvement Act of 1982, (49 USC § 471, Section 47123), as amended, (prohibits discrimination based on race, creed, color, national origin, or sex);
- (g) The Civil Rights Restoration Act of 1987, (PL 100-209), (Broadened the scope, coverage and applicability of Title VI of the Civil Rights Act of 1964, The Age Discrimination Act of 1975 and Section 504 of the Rehabilitation Act of 1973, by expanding the definition of the terms "programs or activities" to include all of the programs or activities of the Federal-aid recipients, sub-recipients and contractors, whether such programs or activities are Federally funded or not);
- (h) Titles II and III of the Americans with Disabilities Act, which prohibit discrimination on the basis of disability in the operation of public entities, public and private transportation systems, places of public accommodation, and certain testing entities (42 U.S.C. §§ 12131-12189) as implemented by Department of Transportation regulations at 49 C.F.R. parts 37 and 38;
- (i) The Federal Aviation Administration's Nondiscrimination statute (49 U.S.C. § 47123) (prohibits discrimination on the basis of race, color, national origin, and sex);
- (j) Executive Order 12898, Federal Actions to Address Environmental Justice in Minority Populations and Low-Income Populations, which ensures Nondiscrimination against minority populations by discouraging programs, policies, and activities with disproportionately high and adverse human health or environmental effects on minority and low-income populations;
- (k) Executive Order 13166, Improving Access to Services for Persons with Limited English Proficiency, and resulting agency guidance, national origin discrimination includes discrimination because of Limited English proficiency (LEP). To ensure compliance with Title VI, you must take reasonable steps to ensure that LEP persons have meaningful access to your programs (70 Fed. Reg. at 74087 to 74100);
- (l) Title IX of the Education Amendments of 1972, as amended, which prohibits you from discriminating because of sex in education programs or activities (20 U.S.C. 1681 et seq).
- (m) Title VII of the Civil Rights Act of 1964 (42 U.S.C. § 2000e et seq., Pub. L. 88-352), (prohibits employment discrimination on the basis of race, color, religion, sex, or national origin).

(4) Additional Title VI Assurances

***The following Title VI Assurances (Appendices B, C and D) shall apply, as applicable*

- (a) Clauses for Deeds Transferring United States Property (1050.2A, Appendix B)

The following clauses will be included in deeds effecting or recording the transfer of real property, structures, or improvements thereon, or granting interest therein from the United States pursuant to the provisions of Assurance 4.

NOW, THEREFORE, the U.S. Department of Transportation as authorized by law and upon the condition that the North Carolina Department of Transportation (NCDOT) will accept title to the lands and maintain the project constructed thereon in accordance with the North Carolina General Assembly, the Regulations for the Administration of the Federal-Aid Highway Program, and the policies and procedures prescribed by the Federal Highway Administration of the U.S. Department of Transportation in accordance and in compliance with all requirements imposed by Title 49, Code of Federal Regulations, U.S. Department of Transportation, Subtitle A, Office of the Secretary, Part 21, Nondiscrimination in Federally-assisted programs of the U.S. Department of Transportation pertaining to and effectuating the provisions of Title VI of the Civil Rights Act of 1964 (78 Stat. 252; 42 U.S.C. § 2000d to 2000d-4), does hereby remise, release, quitclaim and convey unto the NCDOT all the right, title and interest of the U.S. Department of Transportation in and to said lands described in Exhibit A attached hereto and made a part hereof.

(HABENDUM CLAUSE)

TO HAVE AND TO HOLD said lands and interests therein unto the North Carolina Department of Transportation (NCDOT) and its successors forever, subject, however, to the covenants, conditions, restrictions and reservations herein contained as follows, which will remain in effect for the period during which the real property or structures are used for a purpose for which Federal financial assistance is extended or for another purpose involving the provision of similar services or benefits and will be binding on the NCDOT, its successors and assigns.

The NCDOT, in consideration of the conveyance of said lands and interests in lands, does hereby covenant and agree as a covenant running with the land for itself, its successors and assigns, that (1) no person will on the grounds of race, color, or national origin, be excluded from participation in, be denied the benefits of, or be otherwise subjected to discrimination with regard to any facility located wholly or in part on, over, or under such lands hereby conveyed [,] [and]* (2) that the NCDOT will use the lands and interests in lands and interests in lands so conveyed, in compliance with all requirements imposed by or pursuant to Title 49, Code of Federal Regulations, U.S. Department of Transportation, Subtitle A, Office of the Secretary, Part 21, Non-discrimination in Federally-assisted programs of the U.S. Department of Transportation, Effectuation of Title VI of the Civil Rights Act of 1964, and as said Regulations and Acts may be amended [, and (3) that in the event of breach of any of the above-mentioned nondiscrimination conditions, the Department will have a right to enter or re-enter said lands and facilities on said land, and that above described land and facilities will thereon revert to and vest in and become the absolute property of the U.S. Department of Transportation and its assigns as such interest existed prior to this instruction].*

(*Reverter clause and related language to be used only when it is determined that such a clause is necessary in order to make clear the purpose of Title VI.)

(b) Clauses for Transfer of Real Property Acquired or Improved Under the Activity, Facility, or Program (1050.2A, Appendix C)

The following clauses will be included in deeds, licenses, leases, permits, or similar instruments entered into by the North Carolina Department of Transportation (NCDOT) pursuant to the provisions of Assurance 7(a):

1. The (grantee, lessee, permittee, etc. as appropriate) for himself/herself, his/her heirs, personal representatives, successors in interest, and assigns, as a part of the consideration hereof, does hereby covenant and agree [in the case of deeds and leases add "as a covenant running with the land"] that:
 - (i.) In the event facilities are constructed, maintained, or otherwise operated on the property described in this (deed, license, lease, permit, etc.) for a purpose for which a U.S. Department of Transportation activity, facility, or program is extended or for another purpose involving the provision of similar services or benefits, the (grantee, licensee, lessee, permittee, etc.) will maintain and operate such facilities and services in compliance with all requirements imposed by the Acts and Regulations (as may be amended) such that no person on the grounds of race, color, or national origin, will be excluded from participation in, denied the benefits of, or be otherwise subjected to discrimination in the use of said facilities.
2. With respect to licenses, leases, permits, etc., in the event of breach of any of the above Nondiscrimination covenants, the NCDOT will have the right to terminate the (lease, license, permit, etc.) and to enter, re-enter, and repossess said lands and facilities thereon, and hold the same as if the (lease, license, permit, etc.) had never been made or issued. *
3. With respect to a deed, in the event of breach of any of the above Nondiscrimination covenants, the NCDOT will have the right to enter or re-enter the lands and facilities thereon, and the above described lands and facilities will there upon revert to and vest in and become the absolute property of the NCDOT and its assigns. *

(*Reverter clause and related language to be used only when it is determined that such a clause is necessary to make clear the purpose of Title VI.)

(c) Clauses for Construction/Use/Access to Real Property Acquired Under the Activity, Facility or Program (1050.2A, Appendix D)

The following clauses will be included in deeds, licenses, permits, or similar instruments/ agreements entered into by the North Carolina Department of Transportation (NCDOT) pursuant to the provisions of Assurance 7(b):

1. The (grantee, licensee, permittee, etc., as appropriate) for himself/herself, his/her heirs, personal representatives, successors in interest, and assigns, as a part of the consideration hereof, does hereby covenant and agree (in the case of deeds and leases add, "as a covenant running with the land") that (1) no person on the ground of race, color, or national origin, will be excluded from participation in, denied the benefits of, or be otherwise subjected to discrimination in the use of said facilities, (2) that in the construction of any improvements on, over, or under such land, and the furnishing of services thereon, no person on the ground of race, color, or national origin, will be excluded from participation in, denied the benefits of, or otherwise be subjected to discrimination, (3) that the (grantee, licensee, lessee, permittee, etc.) will use the premises in compliance with all other requirements imposed by or pursuant to the Acts and Regulations, as amended, set forth in this Assurance.
2. With respect to (licenses, leases, permits, etc.), in the event of breach of any of the above Non-discrimination covenants, the NCDOT will have the right to terminate the (license, permit, etc., as appropriate) and to enter or re-enter and repossess said land and the facilities thereon, and hold the same as if said (license, permit, etc., as appropriate) had never been made or issued. *
3. With respect to deeds, in the event of breach of any of the above Nondiscrimination covenants, the NCDOT will there upon revert to and vest in and become the absolute property of the NCDOT and its assigns. *

(*Reverter clause and related language to be used only when it is determined that such a clause is necessary to make clear the purpose of Title VI.)

STANDARD SPECIAL PROVISION**ON-THE-JOB TRAINING**

(10-16-07) (Rev. 4-21-15)

Z-10

Description

The North Carolina Department of Transportation will administer a custom version of the Federal On-the-Job Training (OJT) Program, commonly referred to as the Alternate OJT Program. All contractors (existing and newcomers) will be automatically placed in the Alternate Program. Standard OJT requirements typically associated with individual projects will no longer be applied at the project level. Instead, these requirements will be applicable on an annual basis for each contractor administered by the OJT Program Manager.

On the Job Training shall meet the requirements of 23 CFR 230.107 (b), 23 USC – Section 140, this provision and the On-the-Job Training Program Manual.

The Alternate OJT Program will allow a contractor to train employees on Federal, State and privately funded projects located in North Carolina. However, priority shall be given to training employees on NCDOT Federal-Aid funded projects.

Minorities and Women

Developing, training and upgrading of minorities and women toward journeyman level status is a primary objective of this special training provision. Accordingly, the Contractor shall make every effort to enroll minority and women as trainees to the extent that such persons are available within a reasonable area of recruitment. This training commitment is not intended, and shall not be used, to discriminate against any applicant for training, whether a member of a minority group or not.

Assigning Training Goals

The Department, through the OJT Program Manager, will assign training goals for a calendar year based on the contractors' past three years' activity and the contractors' anticipated upcoming year's activity with the Department. At the beginning of each year, all contractors eligible will be contacted by the Department to determine the number of trainees that will be assigned for the upcoming calendar year. At that time the Contractor shall enter into an agreement with the Department to provide a self-imposed on-the-job training program for the calendar year. This agreement will include a specific number of annual training goals agreed to by both parties. The number of training assignments may range from 1 to 15 per contractor per calendar year. The Contractor shall sign an agreement to fulfill their annual goal for the year.\

Training Classifications

The Contractor shall provide on-the-job training aimed at developing full journeyman level workers in the construction craft/operator positions. Preference shall be given to providing training in the following skilled work classifications:

Equipment Operators	Office Engineers
Truck Drivers	Estimators
Carpenters	Iron / Reinforcing Steel Workers
Concrete Finishers	Mechanics
Pipe Layers	Welders

The Department has established common training classifications and their respective training requirements that may be used by the contractors. However, the classifications established are not all-inclusive. Where the training is oriented toward construction applications, training will be allowed in lower-level management positions such as office engineers and estimators. Contractors shall submit new classifications for specific job functions that their employees are performing. The Department will review and recommend for acceptance to FHWA the new classifications proposed by contractors, if applicable. New classifications shall meet the following requirements:

Proposed training classifications are reasonable and realistic based on the job skill classification needs, and

The number of training hours specified in the training classification is consistent with common practices and provides enough time for the trainee to obtain journeyman level status.

The Contractor may allow trainees to be trained by a subcontractor provided that the Contractor retains primary responsibility for meeting the training and this provision is made applicable to the subcontract. However, only the Contractor will receive credit towards the annual goal for the trainee.

Where feasible, 25 percent of apprentices or trainees in each occupation shall be in their first year of apprenticeship or training. The number of trainees shall be distributed among the work classifications on the basis of the contractor's needs and the availability of journeymen in the various classifications within a reasonable area of recruitment.

No employee shall be employed as a trainee in any classification in which they have successfully completed a training course leading to journeyman level status or in which they have been employed as a journeyman.

Records and Reports

The Contractor shall maintain enrollment, monthly and completion reports documenting company compliance under these contract documents. These documents and any other information as requested shall be submitted to the OJT Program Manager.

Upon completion and graduation of the program, the Contractor shall provide each trainee with a certification Certificate showing the type and length of training satisfactorily completed.

Trainee Interviews

All trainees enrolled in the program will receive an initial and Trainee/Post graduate interview conducted by the OJT program staff.

Trainee Wages

Contractors shall compensate trainees on a graduating pay scale based upon a percentage of the prevailing minimum journeyman wages (Davis-Bacon Act). Minimum pay shall be as follows:

60 percent	of the journeyman wage for the first half of the training period
75 percent	of the journeyman wage for the third quarter of the training period
90 percent	of the journeyman wage for the last quarter of the training period

In no instance shall a trainee be paid less than the local minimum wage. The Contractor shall adhere to the minimum hourly wage rate that will satisfy both the NC Department of Labor (NCDOL) and the Department.

Achieving or Failing to Meet Training Goals

The Contractor will be credited for each trainee employed by him on the contract work who is currently enrolled or becomes enrolled in an approved program and who receives training for at least 50 percent of the specific program requirement. Trainees will be allowed to be transferred between projects if required by the Contractor's scheduled workload to meet training goals.

If a contractor fails to attain their training assignments for the calendar year, they may be taken off the NCDOT's Bidders List.

Measurement and Payment

No compensation will be made for providing required training in accordance with these contract documents.

BR-0004

GT-1

Beaufort County

PROJECT SPECIAL PROVISIONS

GEOTECHNICAL

MODIFIED CLASS III (SPECIAL)

GT-1.1 - GT-1.1

DocuSigned by:

Geotechnical Engineering Unit

E06538624A11498...

05/27/2025

MODIFIED CLASS III

(SPECIAL)

Modified Class III shall exclude the A-1 material from Type 2 Select Material of Class III in Section 1016-3 of Standard Specifications. For Modified Class III, use Class III from the 2024 Standard Specifications with following revisions:

Article 1016-3, lines 6-7 of page 10-42, replace with the following:

Type 2 select material is a granular soil material meeting AASHTO M 145 for soil classification A-3.

Article 265-4, line 4 of page 2-31, add the following in the Pay Item:

Pay Item

Select Granular Material, Modified Class III

Pay Unit

Cubic Yard



Signed by:

Saket Kabra

93B8C24A44A248F...

10/08/2024

PROJECT SPECIAL PROVISIONS
Utility Construction

HDR Engineering, Inc. of the Carolinas
555 Fayetteville Street, Suite 900
Raleigh, NC 27601-3034
919.232.6600



(Seal)

DOCUMENT NOT CONSIDERED FINAL
UNLESS ALL SIGNATURES COMPLETED

Where brand names and model numbers are specified in these Special Provisions or in the plans, the cited examples are used only to denote the quality standard of product desired and do not restrict bidders to a specific brand, make, or manufacturer. They are provided to set forth the general style, type, character, and quality of the product desired. Equivalent products will be acceptable.

The utility owner is Beaufort County. The contact person is Erick Jennings and he can be reached by phone at 252-402-6547.

The provisions contained within these Utilities Construction Project Special Provisions modify the *Standard Specifications* only for materials used and work performed constructing water or sewer facilities owned by Beaufort County.

SUBMITTALS AND RECORDS
(9-5-23)

Revise the 2024 *Standard Specifications* as follows:

Page 15-2, Article 1500-7 SUBMITTALS AND RECORDS, lines 29-30, replace the last sentence of the third paragraph with the following:

Engineer and Beaufort County must approve all material submittals before ordering.

THE CONTRACTOR SHALL BE RESPONSIBLE FOR PROVIDING THE ENGINEER AND BEAUFORT COUNTY WITH A SET OF SURVEY RECORD (AS-BUILT) DRAWINGS. PREPARED BY A NORTH CAROLINA REGISTERED LAND SURVEYOR CERTIFYING THE ACCURACY OF THE SURVEY HORIZONTAL AND VERTICAL.

LOCATIONS TO ONE TENTH (0.10) OF A FOOT. SURVEY SHALL BE TIED TO THE NORTH CAROLINA STATE PLANE COORDINATE SYSTEM (NAD83 FEET) HORIZONTALLY, AND ELEVATIONS SHALL BE NORTH AMERICAN VERTICAL DATUM (NAVD88). SURVEY POINT INFORMATION SHALL BE PROVIDED IN AN ELECTRONIC FORMAT (EITHER AN AUTOCAD [VERSION 2020 OR EARLIER] DWG FILE OR AN ASCII POINT TEXT FILE [X-Y COORDINATES]).

THESE DRAWINGS SHALL AT A MINIMUM SHOW THE FINAL ELEVATIONS AND HORIZONTAL LOCATIONS FOR ALL VALVES, HYDRANTS, AND FITTING LOCATIONS.

CONTRACTOR SHALL PROVIDE THE ENGINEER WITH A LETTER CERTIFYING TO THEIR COMPLIANCE WITH THE CONTRACT DRAWINGS.

Page 15-8, Article 1515-3 CONSTRUCTION METHODS, Add the following :

- (H) Sampling Station:
 1. Sampling station shall only be connected to Beaufort County publicly maintained water main, and never connected to any lateral, fire hydrant, air release, surge or blow off assembly.
 2. Sampling station should be installed true and plumb to the surrounding grades prior to placement of the concrete pad.
 3. Sampling station shall be enclosed with a lockable non-removeable aluminum epoxy coated box with hinged opening.
 4. Sampling station shall have all working parts made of stainless steel, with a 2' bury depth stem.
 5. Concrete pad shall be sloped away from sampling station and shall be flush with the surrounding grades.
 6. All underground pipping hall be type "K" copper tubing with approved brass compression fittings.

Page 15-9 Article 1515-4 MEASUREMENT AND PAYMENT, line 32, Add the following after Line Stops:

- ___" Sampling Station"

Page 15-10 Article 1515-4 MEASUREMENT AND PAYMENT, line 14, Add the following after Line Stops:

- ___" Sampling Station" Each

PROJECT SPECIAL PROVISIONS

Utilities by Others



General:

The following utility companies have facilities that will be in conflict with the construction of this project:

- A) Charter- Communications
- B) BrightSpeed- Communications

The conflicting facilities of these concerns will be adjusted post let, an anticipate overall completion of relocation by the let date. All utility work listed herein will be done by the utility owners. All utilities are shown on the plans from the best available information.

The Contractor's attention is directed to Article 105-8 of the 2024 *Standard Specifications*.

Utilities Requiring Adjustment:

Utility relocations are shown on the Utilities by Others Plans.

A) Charter-Communications

- 1) Charter's relocations will be completed prior to the date of availability.
- 2) Charter will bore in a 6-inch duct under the Pango River, which will be shared with BrightSpeed, so that both utilities have a path across the river.
- 3) The contact persons for Charter are Lance Horne, at 910-330-9183
Larry Pucket, at 910-409-9216,
and Randall Smith, at 910-876-3796,

B) BrightSpeed-Communications

- 1) BrightSpeed's relocations will be completed prior to the date of availability.
- 2) The contact persons for BrightSpeed are Craig Littlefield, at 252-406-5985,
and Bruce Sexton, at 919-368-0815

**Project Special Provisions
Erosion Control**

STABILIZATION REQUIREMENTS:

(4-30-2019)(Rev. 1-21-25)

Stabilization for this project shall comply with the time frame guidelines as specified by the NCG-010000 general construction permit issued by the North Carolina Department of Environmental Quality Division of Energy, Mineral and Land Resources. Temporary or permanent ground cover stabilization shall occur within the following time frames from the last land-disturbing activity:

- Stabilize perimeter dikes, swales, ditches, and perimeter slopes within 7 calendar days.
- Stabilize high quality water (HQW) zones within 7 calendar days.
- Stabilize slopes steeper than 3:1 within 7 calendar days.
 - If slopes are 10 feet or less in length and are not steeper than 2:1, 14 calendar days are allowed.
- Stabilize slopes 3:1 to 4:1 within 14 calendar days.
 - 7 calendar days for slopes greater than 50 feet in length and with slopes steeper than 4:1.
 - 7 calendar days for perimeter dikes, swales, ditches, perimeter slopes, and HQW Zones.
- Stabilize areas with slopes flatter than 4:1 within 14 calendar days.
 - 7 calendar days for perimeter dikes, swales, ditches, perimeter slopes, and HQW Zones.

The stabilization timeframe for High Quality Water (HQW) Zones shall be 7 calendar days with no exceptions for slope grades or lengths. High Quality Water Zones (HQW) Zones are defined by North Carolina Administrative Code 15A NCAC 04A.0105 (25). Temporary and permanent ground cover stabilization shall be achieved in accordance with the provisions in this contract and as directed.

SEEDING AND MULCHING:

(East)

The kinds of seed and fertilizer, and the rates of application of seed, fertilizer, and limestone, shall be as stated below. During periods of overlapping dates, the kind of seed to be used shall be determined. All rates are in pounds per acre.

All Roadway Areas

March 1 - August 31

50#	Tall Fescue
10#	Centipede
25#	Bermudagrass (hulled)
500#	Fertilizer
4000#	Limestone

September 1 - February 28

50#	Tall Fescue
10#	Centipede
35#	Bermudagrass (unhulled)
500#	Fertilizer
4000#	Limestone

Waste and Borrow Locations

March 1 – August 31

75#	Tall Fescue
25#	Bermudagrass (hulled)
500#	Fertilizer
4000#	Limestone

September 1 - February 28

75#	Tall Fescue
35#	Bermudagrass (unhulled)
500#	Fertilizer
4000#	Limestone

Note: 50# of Bahiagrass may be substituted for either Centipede or Bermudagrass only upon Engineer's request.

Approved Tall Fescue Cultivars

06 Dust	Escalade	Kalahari	Serengeti
2 nd Millennium	Essential	Kitty Hawk 2000	Shelby
3 rd Millennium	Evergreen 2	Legitimate	Shenandoah III
Avenger	Faith	Lexington	Shenandoah Elite
Bar Fa	Falcon IV	LifeGuard	Sheridan
Barlexas	Falson NG	LSD	Sidewinder
Barlexas II	Falcon V	Magellan	Signia
Barrera	Fat Cat	Masterpiece	Silver Hawk
Barrington	Fesnova	Millennium SRP	Skyline
Barrobusto	Fidelity	Monet	Solara
Barvado	Finelawn Elite	Mustang 4	Southern Choice II
Biltmore	Finelawn Xpress	Naturally Green	Speedway
Bingo	Finesse II	Ninja 2	Spyder LS
Bizem	Firebird	Ol' Glory	Sunset Gold
Black Tail	Firecracker LS	Padre	Taccoa
Blackwatch	Firenza	Patagonia	Tahoe II
Blade Runner II	Five Point	Pedigree	Talladega
Bonsai	Focus	Picasso	Tanzania
Braveheart	Forte	Piedmont	Temple
Bravo	Garrison	Plantation	Terrano
Bullseye	Gazelle II	Proseeds 5301	Thor
Cannavaro	GLX Aced	Prospect	Thunderstruck
Catalyst	Gold Medallion	Quest	Titanium LS
Cayenne	Grande 3	RainDance	Titan LTD
Cezanne RZ	Greenbrooks	Raptor II	Tracer
Chipper	Greenkeeper	Rebel IV	Traverse SRP
Cochise IV	Gremlin	Rebel Exeda	Trio
Constitution	Greystone	Rebel Sentry	Tulsa Time
Corgi	Guardian 21	Regenerate	Turbo
Corona	Guardian 41	Regiment II	Turbo RZ
Coyote	Hemi	Rembrandt	Tuxedo
Cumberland	Honky Tonk	Rendition	Ultimate
Darlington	Hot Rod	Reunion	Umbrella
DaVinci	Hunter	Rhambler 2 SRP	Van Gogh

Desire	Inferno	Riverside	Venture
Diablo	Integrity	RNP	Watchdog
Dominion	Jaguar 3	Rocket	Wolfpack II
Dynamic	Jamboree	Saltillo	Xtremegreen
Dynasty	Justice	Scorpion	

On cut and fill slopes 2:1 or steeper Centipede shall be applied at the rate of 5 pounds per acre and add 20# of Sericea Lespedeza from January 1 - December 31.

Fertilizer shall be 10-20-20 analysis. A different analysis of fertilizer may be used provided the 1-2-2 ratio is maintained and the rate of application adjusted to provide the same amount of plant food as a 10-20-20 analysis and as directed.

Native Grass Seeding and Mulching

(East)

Native Grass Seeding and Mulching shall be performed on the disturbed areas of wetlands and riparian areas, and adjacent to Stream Relocation construction within a 50 foot zone on both sides of the stream or depression, measured from top of stream bank or center of depression. The stream bank of the stream relocation shall be seeded by a method that does not alter the typical cross section of the stream bank. Native Grass Seeding and Mulching shall also be performed in the permanent soil reinforcement mat section of preformed scour holes, and in other areas as directed.

The kinds of seed and fertilizer, and the rates of application of seed, fertilizer, and limestone, shall be as stated below. During periods of overlapping dates, the kind of seed to be used shall be determined. All rates are in pounds per acre.

March 1 - August 31		September 1 - February 28	
18#	Creeping Red Fescue	18#	Creeping Red Fescue
6#	Indiangrass	6#	Indiangrass
8#	Little Bluestem	8#	Little Bluestem
4#	Switchgrass	4#	Switchgrass
25#	Browntop Millet	35#	Rye Grain
500#	Fertilizer	500#	Fertilizer
4000#	Limestone	4000#	Limestone

Approved Creeping Red Fescue Cultivars:

Aberdeen	Boreal	Epic	Cindy Lou
----------	--------	------	-----------

Fertilizer shall be 10-20-20 analysis. A different analysis of fertilizer may be used provided the 1-2-2 ratio is maintained and the rate of application adjusted to provide the same amount of plant food as a 10-20-20 analysis and as directed.

Native Grass Seeding and Mulching shall be performed in accordance with Section 1660 of the *Standard Specifications* and vegetative cover sufficient to restrain erosion shall be installed immediately following grade establishment.

Measurement and Payment

Native Grass *Seeding and Mulching* will be measured and paid for in accordance with Article 1660-8 of the *Standard Specifications*.

All areas seeded and mulched shall be tacked with asphalt. Crimping of straw in lieu of asphalt tack shall not be allowed on this project.

CRIMPING STRAW MULCH:

Crimping shall be required on this project adjacent to any section of roadway where traffic is to be maintained or allowed during construction. In areas within six feet of the edge of pavement, straw is to be applied and then crimped. After the crimping operation is complete, an additional application of straw shall be applied and immediately tacked with a sufficient amount of undiluted emulsified asphalt.

Straw mulch shall be of sufficient length and quality to withstand the crimping operation.

Crimping equipment including power source shall be subject to the approval of the Engineer providing that maximum spacing of crimper blades shall not exceed 8".

TEMPORARY SEEDING:

Fertilizer shall be the same analysis as specified for *Seeding and Mulching* and applied at the rate of 400 pounds and seeded at the rate of 50 pounds per acre. Sweet Sudan Grass, German Millet or Browntop Millet shall be used in summer months and Rye Grain during the remainder of the year. The Engineer will determine the exact dates for using each kind of seed.

FERTILIZER TOPDRESSING:

Fertilizer used for topdressing on all roadway areas except slopes 2:1 and steeper shall be 10-20-20 grade and shall be applied at the rate of 500 pounds per acre. A different analysis of fertilizer may be used provided the 1-2-2 ratio is maintained and the rate of application adjusted to provide the same amount of plant food as 10-20-20 analysis and as directed.

Fertilizer used for topdressing on slopes 2:1 and steeper and waste and borrow areas shall be 16-8-8 grade and shall be applied at the rate of 500 pounds per acre. A different analysis of fertilizer may be used provided the 2-1-1 ratio is maintained and the rate of application adjusted to provide the same amount of plant food as 16-8-8 analysis and as directed.

SUPPLEMENTAL SEEDING:

The kinds of seed and proportions shall be the same as specified for *Seeding and Mulching*, with the exception that no centipede seed will be used in the seed mix for supplemental seeding. The rate of application for supplemental seeding may vary from 25# to 75# per acre. The actual rate

per acre will be determined prior to the time of topdressing and the Contractor will be notified in writing of the rate per acre, total quantity needed, and areas on which to apply the supplemental seed. Minimum tillage equipment, consisting of a sod seeder shall be used for incorporating seed into the soil as to prevent disturbance of existing vegetation. A clodbuster (ball and chain) may be used where degree of slope prevents the use of a sod seeder.

MOWING:

The minimum mowing height on this project shall be 4 inches.

LAWN TYPE APPEARANCE:

All areas adjacent to lawns must be hand finished as directed to give a lawn type appearance. Remove all trash, debris, and stones $\frac{3}{4}$ " and larger in diameter or other obstructions that could interfere with providing a smooth lawn type appearance. These areas shall be reseeded to match their original vegetative conditions, unless directed otherwise by the Field Operations Engineer.

REFORESTATION:

Description

Reforestation will be planted within interchanges and along the outside borders of the road, and in other areas as directed. *Reforestation* is not shown on the plan sheets. See the Reforestation Detail Sheet.

All non-maintained riparian buffers impacted by the placement of temporary fill or clearing activities shall be restored to the preconstruction contours and revegetated with native woody species.

The entire *Reforestation* operation shall comply with the requirements of Section 1670 of the *Standard Specifications*.

Materials

Reforestation shall be bare root seedlings 12"-18" tall.

Construction Methods

Reforestation shall be planted as soon as practical following permanent *Seeding and Mulching*. The seedlings shall be planted in a 16-foot wide swath adjacent to mowing pattern line, or as directed.

Root dip: The roots of reforestation seedlings shall be coated with a slurry of water, and either a fine clay (kaolin) or a superabsorbent that is designated as a bare root dip. The type, mixture ratio, method of application, and the time of application shall be submitted to the Engineer for approval.

With the approval of the Engineer, seedlings may be coated before delivery to the job or at the time of planting, but at no time shall the roots of the seedlings be allowed to dry out. The roots shall be moistened immediately prior to planting.

Seasonal Limitations: *Reforestation* shall be planted from November 15 through March 15.

Measurement and Payment

Reforestation will be measured and paid for in accordance with Article 1670-17 of the *Standard Specifications*.

WETLAND REFORESTATION:

Description

Wetland Reforestation will be planted in areas designated on the plans and as directed. See the Wetland Reforestation Detail Sheet.

The entire *Wetland Reforestation* operation shall comply with the requirements of Section 1670 of the *Standard Specifications*.

Materials

Wetland Reforestation shall be bare root seedlings 12"-18" tall.

Construction Methods

Wetland Reforestation shall be planted as soon as practical following permanent seeding and mulching. The seedlings shall be planted in a minimum of two rows of trees between the slope stake line and the clearing limits.

Root dip: the roots of reforestation seedlings shall be coated with a slurry of water, and either a fine clay ("kaolin") or a superabsorbent that is made to be used as a bare root dip. The type, mixture ratio, method of application, and the time of application shall be submitted to the Engineer for approval.

With the approval of the Engineer, seedlings may be coated before delivery to the job or at the time of planting, but at no time shall the roots of the seedlings be allowed to dry out. The roots shall be moistened immediately prior to planting.

Seasonal limitations: *Wetland Reforestation* shall be planted from November 15 through March 15.

Measurement and Payment

Wetland Reforestation will be measured and paid for in accordance with Article 1670-17 of the *Standard Specifications*.

RIPPING:

Description

This work consists of ripping the areas graded for planting with wetland reforestation with a v ripper tillage tool.

Materials

The v ripper tillage tool shall have a minimum of three shanks spaced a maximum of 20 inches apart and have shanks of sufficient length capable of providing a minimum depth of 15 inches. The tractor used to perform this work shall be of sufficient size and horsepower capable of pulling this implement to the minimum specifications stated above.

Construction Methods

Upon completion of grading, the areas to be planted with wetland reforestation shall be ripped with a v ripper tillage tool to a minimum depth of 15 inches. Each sequential swath of the equipment shall be consistent in spacing and shall have a maximum of 20 inches between swaths.

Measurement and Payment

Ripping will be measured and paid for as the actual number of acres measured along the surface of the ground, which has been ripped.

Payment will be made under:

Pay Item	Pay Unit
Ripping	Acre

DISKING:

Description

Upon completion of *Ripping*, *Disking* shall be performed in all areas shown on the plans or as directed.

Materials

The disk harrow equipment shall be either a tandem disk harrow or an offset disk harrow with 20" blades minimum, spaced a maximum of 9" apart. The disk harrow shall have a minimum of 18 blades, and shall be of sufficient weight and size to provide an 8" minimum cutting depth. The

tractor used to perform this work shall be of sufficient size and horsepower capable of pulling this implement to the minimum specifications stated above.

Construction Methods

The areas previously ripped shall be disked to a minimum depth of 8" and shall provide adequate mixing of vegetation debris into the soil.

Measurement and Payment

Disking will be measured and paid for as the actual number of acres measured along the surface of the ground, which has been disked.

Payment will be made under:

Pay Item	Pay Unit
Disking	Acre

WETLAND GRASS PLANTING:

Description

Wetland Grass Planting will be planted in areas where the existing causeway fill is removed down to the adjacent marsh elevation, and in other areas as directed. See the Wetland Grass Planting Detail Sheet.

Materials

Plant material shall be delivered in 2" peat pots in cell packs of approximately 50 plants per tray. Plant material shall consist of 3 to 5 stems per plant and shall be rooted through the sides and bottom of the peat pot.

Construction Methods

The Contractor shall be responsible for taking sufficient soil samples for testing by the North Carolina Department of Agriculture and Consumer Services, Agronomic Division, Soil Testing Section, to determine the soil pH and nutrient content. Samples shall be taken in the presence of the Engineer. Results shall be received by the Engineer directly from the North Carolina Department of Agriculture and Consumer Services. The Contractor shall be responsible for the addition of fertilizer and/or other soil amendments as needed to ensure livability of the wetland grass planting.

The plant plugs shall be planted upright, not at an angle. Planting holes shall be dug large enough and deep enough to accommodate the entire root mass. The plant plugs shall be planted without twisted, balled, *j* or *u* roots. The plant plugs shall be planted with no roots exposed above the ground line. Soil shall be packed firmly around the entire root mass.

The Contractor shall supply and install a slow release, coated fertilizer (14-14-14) at the rate of one ounce per plant hole and shall be placed in the transplant hole prior to placing the plug. Another fertilizer analysis may be substituted, upon written approval of the Engineer.

Seasonal limitations: *Wetland Grass Planting* shall be completed between April 15 and May 15. No planting shall be done when the temperature is below 32 degrees F, when the soil to be excavated for the planting hole is frozen, or when the bottoms of the plant holes are frozen.

Measurement and Payment

Wetland Grass Planting will be measured and paid for as the actual number of acres of land, measured along of the surface of ground, which has been acceptably planted with grasses in accordance with these specifications.

Payment will be made under:

Pay Item	Pay Unit
Wetland Grass Planting	Acre

ENVIRONMENTALLY SENSITIVE AREAS:

Description

This project is located in an *Environmentally Sensitive Area*. This designation requires special procedures to be used for clearing and grubbing, temporary stream crossings, and grading operations within the Environmentally Sensitive Areas identified on the plans and as designated by the Engineer. This also requires special procedures to be used for seeding and mulching and staged seeding within the project.

The Environmentally Sensitive Area shall be defined as a 50-foot buffer zone on both sides of the stream or depression measured from top of streambank or center of depression.

Construction Methods

(A) Clearing and Grubbing

In areas identified as Environmentally Sensitive Areas, the Contractor may perform clearing operations, but not grubbing operations until immediately prior to beginning grading operations as described in Article 200-1 of the *Standard Specifications*. Only clearing operations (not grubbing) shall be allowed in this buffer zone until immediately prior to beginning grading operations. Erosion control devices shall be installed immediately following the clearing operation.

(B) Grading

Once grading operations begin in identified Environmentally Sensitive Areas, work shall progress in a continuous manner until complete. All construction within these areas shall progress in a continuous manner such that each phase is complete and areas are permanently stabilized prior to beginning of next phase. Failure on the part of the Contractor to complete any phase of construction in a continuous manner in Environmentally Sensitive Areas will be just cause for the Engineer to direct the suspension of work in accordance with Article 108-7 of the *Standard Specifications*.

(C) Temporary Stream Crossings

Any crossing of streams within the limits of this project shall be accomplished in accordance with the requirements of Subarticle 107-12 of the *Standard Specifications*.

(D) Seeding and Mulching

Seeding and mulching shall be performed in accordance with Section 1660 of the *Standard Specifications* and vegetative cover sufficient to restrain erosion shall be installed immediately following grade establishment.

Seeding and mulching shall be performed on the areas disturbed by construction immediately following final grade establishment. No appreciable time shall lapse into the contract time without stabilization of slopes, ditches and other areas within the Environmentally Sensitive Areas.

(E) Stage Seeding

The work covered by this section shall consist of the establishment of a vegetative cover on cut and fill slopes as grading progresses. Seeding and mulching shall be done in stages on cut and fill slopes that are greater than 20 feet in height measured along the slope, or greater than 2 acres in area. Each stage shall not exceed the limits stated above.

Additional payments will not be made for the requirements of this section, as the cost for this work shall be included in the contract unit prices for the work involved.

MINIMIZE REMOVAL OF VEGETATION:

The Contractor shall minimize removal of vegetation within project limits to the maximum extent practicable. Vegetation along stream banks and adjacent to other jurisdictional resources outside the construction limits shall only be removed upon approval of Engineer. No additional payment will be made for this minimization work.

CONSTRUCTION MATERIALS MANAGEMENT

(3-19-19) (rev. 04-27-20)

Description

The requirements set forth shall be adhered to in order to meet the applicable materials handling requirements of the NCG010000 permit. Structural controls installed to manage construction materials stored or used on site shall be shown on the E&SC Plan. Requirements for handling materials on construction sites shall be as follows:

Polyacrylamides (PAMS) and Flocculants

Polyacrylamides (PAMS) and flocculants shall be stored in leak-proof containers that are kept under storm-resistant cover or surrounded by secondary containment structures designed to protect adjacent surface waters. PAMS or other flocculants used shall be selected from the NC DWR List of Approved PAMS/Flocculants. The concentration of PAMS and other flocculants used shall not exceed those specified in the NC DWR List of Approved PAMS/Flocculants and in accordance with the manufacturer's instructions. The NC DWR List of Approved PAMS/Flocculants is available at:

https://files.nc.gov/ncdeq/Water+Quality/Environmental+Sciences/ATU/PAM8_30_18.pdf

Equipment Fluids

Fuels, lubricants, coolants, and hydraulic fluids, and other petroleum products shall be handled and disposed of in a manner so as not to enter surface or ground waters and in accordance with applicable state and federal regulations. Equipment used on the site must be operated and maintained properly to prevent discharge of fluids. Equipment, vehicle, and other wash waters shall not be discharged into E&SC basins or other E&SC devices. Alternative controls should be provided such that there is no discharge of soaps, solvents, or detergents.

Waste Materials

Construction materials and land clearing waste shall be disposed of in accordance with North Carolina General Statutes, Chapter 130A, Article 9 - Solid Waste Management, and rules governing the disposal of solid waste (15A NCAC 13B). Areas dedicated for managing construction material and land clearing waste shall be at least 50 feet away from storm drain inlets and surface waters unless it can be shown that no other alternatives are reasonably available. Paint and other liquid construction material waste shall not be dumped into storm drains. Paint and other liquid construction waste washouts should be located at least 50 feet away from storm drain inlets unless there is no alternative. Other options are to install lined washouts or use portable, removable bags or bins. Hazardous or toxic waste shall be managed in accordance with the federal Resource Conservation and Recovery Act (RCRA) and NC Hazardous Waste Rules at 15A NCAC, Subchapter 13A. Litter and sanitary waste shall be managed in a manner to prevent it from entering jurisdictional waters and shall be disposed of offsite.

Herbicide, Pesticide, and Rodenticides

Herbicide, pesticide, and rodenticides shall be stored and applied in accordance with the Federal Insecticide, Fungicide, and Rodenticide Act, North Carolina Pesticide Law of 1971 and labeling restrictions.

Concrete Materials

Concrete materials onsite, including excess concrete, must be controlled and managed to avoid contact with surface waters, wetlands or buffers. No concrete or cement slurry shall be discharged from the site. (Note that discharges from onsite concrete plants require coverage under a separate NPDES permit – NCG140000.) Concrete wash water shall be managed in accordance with the *Concrete Washout Structure* provision. Concrete slurry shall be managed and disposed of in accordance with *NCDOT DGS and HOS DCAR Distribution of Class A Residuals Statewide* (Permit No. WQ0035749). Any hardened concrete residue will be disposed of, or recycled on site, in accordance with state solid waste regulations.

Earthen Material Stock Piles

Earthen material stock piles shall be located at least 50 feet away from storm drain inlets and surface waters unless it can be shown that no other alternatives are reasonably available.

Measurement and Payment

Conditions set within the *Construction Materials Management* provision are incidental to the project for which no direct compensation will be made.

WASTE AND BORROW SOURCES:

(2-16-11) (Rev. 3-17-22)

Payment for temporary erosion control measures, except those made necessary by the Contractor's own negligence or for his own convenience, will be paid for at the appropriate contract unit price for the devices or measures utilized in borrow sources and waste areas.

No additional payment will be made for erosion control devices or permanent seeding and mulching in any commercial borrow or waste pit. All erosion and sediment control practices that may be required on a commercial borrow or waste site will be done at the Contractor's expense.

All offsite Staging Areas, Borrow and Waste sites shall be in accordance with "Borrow and Waste Site Reclamation Procedures for Contracted Projects" located at:

<https://connect.ncdot.gov/resources/roadside/FieldOperationsDocuments/Contract%20Reclamation%20Procedures.pdf>

All forms and documents referenced in the "Borrow and Waste Site Reclamation Procedures for Contracted Projects" shall be included with the reclamation plans for offsite staging areas, and borrow and waste sites.

SAFETY FENCE AND JURISDICTIONAL FLAGGING:**Description**

Safety Fence shall consist of furnishing materials, installing and maintaining polyethylene or polypropylene fence along the outside riparian buffer, wetland, or water boundary, or other boundaries located within the construction corridor to mark the areas that have been approved to infringe within the buffer, wetland, endangered vegetation, culturally sensitive areas or water. The fence shall be installed prior to any land disturbing activities.

Interior boundaries for jurisdictional areas noted above shall be delineated by stakes and highly visible flagging.

Jurisdictional boundaries at staging areas, waste sites, or borrow pits, whether considered outside or interior boundaries shall be delineated by stakes and highly visible flagging.

Materials**(A) Safety Fencing**

Polyethylene or polypropylene fence shall be a highly visible preconstructed safety fence approved by the Engineer. The fence material shall have an ultraviolet coating.

Either wood posts or steel posts may be used. Wood posts shall be hardwood with a wedge or pencil tip at one end, and shall be at least 5 ft. in length with a minimum nominal 2" x 2" cross section. Steel posts shall be at least 5 ft. in length, and have a minimum weight of 0.85 lb/ft of length.

(B) Boundary Flagging

Wooden stakes shall be 4 feet in length with a minimum nominal 3/4" x 1-3/4" cross section. The flagging shall be at least 1" in width. The flagging material shall be vinyl and shall be orange in color and highly visible.

Construction Methods

No additional clearing and grubbing is anticipated for the installation of this fence. The fence shall be erected to conform to the general contour of the ground.

(A) Safety Fencing

Posts shall be set at a maximum spacing of 10 ft., maintained in a vertical position and hand set or set with a post driver. Posts shall be installed a minimum of 2 ft. into the ground. If hand set, all backfill material shall be thoroughly tamped. Wood posts may be sharpened to a dull point if power driven. Posts damaged by power driving shall be removed and replaced prior to final

acceptance. The tops of all wood posts shall be cut at a 30-degree angle. The wood posts may, at the option of the Contractor, be cut at this angle either before or after the posts are erected.

The fence geotextile shall be attached to the wood posts with one 2" galvanized wire staple across each cable or to the steel posts with wire or other acceptable means.

Place construction stakes to establish the location of the safety fence in accordance with Article 105-9 or Article 801-1 of the *Standard Specifications*. No direct pay will be made for the staking of the safety fence. All stakeouts for safety fence shall be considered incidental to the work being paid for as "Construction Surveying", except that where there is no pay item for construction surveying, all safety fence stakeout will be performed by state forces.

The Contractor shall be required to maintain the safety fence in a satisfactory condition for the duration of the project as determined by the Engineer.

(B) Boundary Flagging

Boundary flagging delineation of interior boundaries shall consist of wooden stakes on 25 feet maximum intervals with highly visible orange flagging attached. Stakes shall be installed a minimum of 6" into the ground. Interior boundaries may be staked on a tangent that runs parallel to buffer but must not encroach on the buffer at any location. Interior boundaries of hand clearing shall be identified with a different colored flagging to distinguish it from mechanized clearing.

Boundary flagging delineation of interior boundaries will be placed in accordance with Article 105-9 or Article 801-1 of the *Standard Specifications*. No direct pay will be made for delineation of the interior boundaries. This delineation will be considered incidental to the work being paid for as *Construction Surveying*, except that where there is no pay item or construction surveying the cost of boundary flagging delineation shall be included in the unit prices bid for the various items in the contract. Installation for delineation of all jurisdictional boundaries at staging areas, waste sites, or borrow pits shall consist of wooden stakes on 25 feet maximum intervals with highly visible orange flagging attached. Stakes shall be installed a minimum of 6" into the ground. Additional flagging may be placed on overhanging vegetation to enhance visibility but does not substitute for installation of stakes.

Installation of boundary flagging for delineation of all jurisdictional boundaries at staging areas, waste sites, or borrow pits shall be performed in accordance with Subarticle 230-4(B)(5) or Subarticle 802-2(F) of the *Standard Specifications*. No direct pay will be made for this delineation, as the cost of same shall be included in the unit prices bid for the various items in the contract.

The Contractor shall be required to maintain alternative stakes and highly visible flagging in a satisfactory condition for the duration of the project as determined by the Engineer.

Measurement and Payment

Safety Fence will be measured and paid as the actual number of linear feet of polyethylene or polypropylene fence installed in place and accepted. Such payment will be full compensation

including but not limited to furnishing and installing fence geotextile with necessary posts and post bracing, staples, tie wires, tools, equipment and incidentals necessary to complete this work.

Payment will be made under:

Pay Item

Safety Fence

Pay Unit

Linear Foot

FLOATING TURBIDITY CURTAIN:

Description

This work consists of furnishing a *Floating Turbidity Curtain* to deter silt suspension and movement of silt particles during construction. The floating turbidity curtain shall be constructed at locations as directed.

Materials

The curtain material shall be made of a tightly woven nylon, plastic or other non-deteriorating material meeting the following specifications:

Property	Value
Grab tensile strength	*md-370 lbs *cd-250 lbs
Mullen burst strength	480 psi
Trapezoid tear strength	*md-100 lbs *cd-60 lbs
Apparent opening size	70 US standard sieve
Percent open area	4% permittivity 0.28 sec-1

*md - machine direction

*cd - cross machine direction

In the event that more than one width of fabric is required, a 6" overlap of the material shall also be required.

The curtain material shall be supported by a flotation material having over 29 lbs/ft buoyancy. The floating curtain shall have a 5/16" galvanized chain as ballast and dual 5/16" galvanized wire ropes with a heavy vinyl coating as load lines.

Construction Methods

The Contractor shall maintain the *Floating Turbidity Curtain* in a satisfactory condition until its removal is requested by the Engineer. The curtain shall extend to the bottom of the jurisdictional resource. Anchor the curtain according to manufacturer recommendations.

Measurement and Payment

Floating Turbidity Curtain will be measured and paid for as the actual number of square yards of curtain furnished as specified and accepted. Such price and payment will be full compensation for the work as described in this section including but not limited to furnishing all materials, tools, equipment, and all incidentals necessary to complete the work.

Payment will be made under:

Pay Item	Pay Unit
Floating Turbidity Curtain	Square Yard

CONCRETE WASHOUT:

(10-22-15)(Rev. 4-15-25)

Description

Concrete washouts are impermeable enclosures, above or below grade, to contain concrete wastewater and associated concrete mix from cleaning of ready-mix trucks, drums, pumps, tools or other equipment. Concrete washouts must collect and retain all the concrete washout water and solids, so that this material does not migrate to surface waters or into the ground water. These enclosures are not intended for concrete waste not associated with washout operations.

Acceptable concrete washouts may include constructed earthen structures, above or below ground, or commercially available devices designed specifically to capture concrete wash water.

Materials

Refer to Division 10 of the *Standard Specifications*.

Item	Section
Temporary Silt Fence	1605

Safety Fence shall meet the specifications as provided elsewhere in this contract.

Geomembrane basin liner shall consist of a minimum 10 mil thick polypropylene or polyethylene geomembrane.

Construction Methods

Build an enclosed earthen berm or excavate to form an enclosure in accordance with the details and as directed by the Engineer near the project entrance(s) or at location(s) of concrete operations. Structures shall be constructed a minimum of 50 feet from drainage conveyances or jurisdictional streams or wetlands. [Alternate structure designs or plans for management of concrete washout may be submitted for review and approval by the Engineer. Include in the alternate plan the method used to retain, treat and dispose of the concrete washout wastewater generated within the project limits and in accordance with the minimum setback requirements.](#)

Install temporary silt fence around the perimeter of the structure enclosure in accordance with the details and as directed by the Engineer if the structure is not located in an area where existing erosion and sedimentation control devices are capable of containing stormwater runoff.

Post a sign with the words “Concrete Washout” in close proximity of the concrete washout area, so it is clearly visible to site personnel. Install safety fence as directed by the Engineer for visibility to construction traffic.

Install prefabricated concrete washouts, designed specifically to capture concrete wash water, at locations of additional concrete pouring operations. Acceptable systems may include geotextile lined containers, vinyl or plastic containers or roll-off containers, with or without filter bags with a minimum functional holding capacity of 36 cubic feet (1.33 cubic yards). Submit prefabricated concrete washout system for approval by the Engineer prior to installation. Place prefabricated concrete washout devices to a minimum 50 foot setback from drainage conveyances and jurisdictional streams and wetlands. If the minimum setback cannot be achieved, provide secondary containment to prevent accidental release of wastewater from reaching drainage conveyances or streams.

Prefabricated concrete washouts must be clearly and visibly labeled as such, either by the manufacturer on the product itself, or by a sign with the words “Concrete Washout” in close proximity of the concrete washout area so it is clearly visible to site personnel.

Maintenance and Removal

Maintain the concrete washout structure(s) to provide adequate holding capacity plus a minimum freeboard of 12 inches. Remove and dispose of hardened concrete and return the structure to a functional condition after reaching 75% capacity. Inspect concrete washout structures for damage to liner or structure to maintain functionality.

Maintain prefabricated concrete washout systems per manufacturer’s recommendations. Inspect concrete washout structures for damage to linings or structure and repair or replace as necessary.

Remove the concrete washout structures and sign upon project completion. Grade the area to match the existing topography and permanently seed and mulch area. Dispose of prefabricated concrete washout structures according to state or local waste regulations.

Measurement and Payment

Concrete Washout Structure will be measured and paid per each enclosure installed in accordance with the details in the plans. If alternate plans or details are approved, those structures will also be paid for per each approved and installed structure. Such price and payment will be full compensation for all work including, but not limited to, furnishing all materials, labor, equipment, signage, slurry solidification and incidentals necessary to construct, maintain and remove *Concrete Washout Structure* and dispose of residual concrete washout wastewater and concrete solids.

Prefabricated Concrete Washout will be measured and paid per each system installed in accordance with the manufacturer's recommendations. Such price and payment will be full compensation for all work including, but not limited to, furnishing all materials, labor, equipment, signage, slurry solidification and incidentals necessary to install, maintain and remove *Prefabricated Concrete Washout*, and dispose of residual concrete washout wastewater and concrete solids.

Temporary Silt Fence will be measured and paid for in accordance with Article 1605-5 of the *Standard Specifications*.

Safety Fence shall be measured and paid for as provided elsewhere in this contract.

No measurement will be made for over excavation or stockpiling or other items necessary to complete this work.

Payment will be made under:

Pay Item	Pay Unit
Concrete Washout Structure	Each
Prefabricated Concrete Washout	Each

LITTER REMOVAL (MOWING AREAS ONLY):

(07-19-22) (Rev 8-25-25)

Description

This work consists of the pickup, removal, and disposal of litter from roadsides within the construction project prior to mowing operations.

Construction Methods

Provide labor, equipment and materials necessary for the pickup and removal of litter from non-construction sources and the disposal of same into state approved landfills. The Contractor shall abide by all ordinances, laws and regulations regarding disposal of litter and recycling of eligible materials. Wastes generated from construction activities shall be managed as provided elsewhere in the contract. Litter items may consist of any item not considered normal to the right-of-way, including but not limited to, varied sizes of bottles, cans, paper, tires, tire pieces, lumber, vehicle parts, building supplies, metals, household furnishings, cardboard, plastics, ladders, brush and other items not considered normal to the right of way. Litter removal shall be performed in designated areas within five days prior to any mowing operations and as directed. Designated areas shall include vegetated medians and shoulders within the project limits including all interchange ramps and other areas to be mown. Designated areas may be omitted for litter removal by the Engineer due to safety concerns.

The Contractor shall provide adequate personnel and materials to collect and remove litter. The Contractor shall be responsible for locating and utilizing approved local landfills and recycling

facilities. Refer to Section 107-25 of the *Standard Specifications* for potential hazardous materials. All collected litter shall be containerized immediately and kept off the traveled portions of the roadway, shoulders, and rights-of-way (including paved shoulders). All collected litter that is small enough to be placed in a bag shall be bagged immediately. All collected litter that is too large for a bag shall be placed into a vehicle. Extended storage or stockpiling of collected litter and recyclables will not be permitted.

The Contractor's personnel shall dispose of any litter in a landfill approved by North Carolina Division of Waste Management. The Contractor will not be allowed to use NCDOT accounts at the landfills/recycling centers nor be allowed to dispose of the litter in NCDOT trash containers on any NCDOT property.

The Contractor shall report online the number of bags of litter and any recycling on the NCDOT Litter Management Website on the date of the pickup at the following website:

<https://apps.ncdot.gov/LM>

An access code ('Pickup Key') for the online reporting portal may be obtained via emailing the Roadside Environmental Unit Litter Management Section at ncdot.clr@ncdot.gov. The Contractor shall request access to the litter removal reporting website prior to starting initial litter collection operations.

Measurement and Payment

The quantity of litter removal to be performed will be affected by the actual conditions that occur during construction of the project. The quantity of litter removal may be increased, decreased, or eliminated entirely as directed. Such variations in quantity will not be considered as alterations in the details of construction or a change in the character of the work.

Manual Litter Removal will be measured and paid as the actual number of man hours each worker spends picking up litter. Such price and payment will be full compensation for all litter removal work covered by *Litter Removal*, including, but not limited to, furnishing all materials, labor, equipment, transport, reporting, and incidentals necessary to accomplish the work.

Litter Disposal will be measured and paid for by the actual number of tons of litter collected and properly disposed of at a state approved landfill. Such price and payment will be full compensation for all fees, labor, transport, and incidentals necessary to dispose of collected litter associated with *Litter Removal*.

All traffic control necessary to provide a safe work area for *Litter Removal* shall be paid for as specified elsewhere in the contract.

Payment will be made under:

Pay Item

Pay Unit

Manual Litter Removal
Litter Disposal

MHR
TON

ST-1

Project BR-0004

Beaufort County

Project Special Provisions

Structure

Table of Contents

		Page #
Falsework and Formwork	(11-30-23)	ST-2
Submittal of Working Drawings	(1-31-25)	ST-9
Crane Safety	(12-5-25)	ST-15
Grout for Structures	(12-1-17)	ST-16
Securing of Vessels	(10-12-01)	ST-17
Construction, Maintenance and Removal of Temporary Access at Station 23+50 -L-	(12-12-13)	ST-18
Thermal Sprayed Coatings (Metallization)	(12-1-17)	ST-19
Strip Seal Expansion Joints	(6-25-20)	ST-21
Asbestos Assessment	(11-30-23)	ST-26



Kent Dickens

1/15/2026

ST-2

Project BR-0004

Beaufort County

PROJECT SPECIAL **PROVISIONS STRUCTURE**

FALSEWORK AND FORMWORK

(11-30-23)

GENERAL

Use this Special Provision as a guide to develop temporary works submittals required by the *Standard Specifications* or other provisions; no additional submittals are required herein. Such temporary works include, but are not limited to, falsework and formwork.

Falsework is any temporary construction used to support the permanent structure until it becomes self-supporting. Formwork is the temporary structure or mold used to retain plastic or fluid concrete in its designated shape until it hardens. Access scaffolding is a temporary structure that functions as a work platform that supports construction personnel, materials, and tools, but is not intended to support the structure. Scaffolding systems that are used to temporarily support permanent structures (as opposed to functioning as work platforms) are considered to be falsework under the definitions given. Shoring is a component of falsework such as horizontal, vertical, or inclined support members. Where the term “temporary works” is used, it includes all of the temporary facilities used in bridge construction that do not become part of the permanent structure.

Design and construct safe and adequate temporary works that will support all loads imposed and provide the necessary rigidity to achieve the lines and grades shown on the plans in the final structure.

MATERIALS

Select materials suitable for temporary works; however, select materials that also ensure the safety and quality required by the design assumptions. The Engineer has authority to reject material on the basis of its condition, inappropriate use, safety, or nonconformance with the plans. Clearly identify allowable loads or stresses for all materials or manufactured devices on the plans. Revise the plan and notify the Engineer if any change to materials or material strengths is required.

DESIGN REQUIREMENTS

(A) Working Drawings

Provide working drawings for items as specified in the contract, or as required by the Engineer, with design calculations and supporting data in sufficient detail to permit a structural and safety review of the proposed design of the temporary work.

On the drawings, show all information necessary to allow the design of any component to be checked independently as determined by the Engineer.

When concrete placement is involved, include data such as the drawings of proposed sequence, rate of placement, direction of placement, and location of all construction joints.

ST-3

Project BR-0004

Beaufort County

When required, have the drawings and calculations prepared under the guidance of, and sealed by, a North Carolina Registered Professional Engineer who is knowledgeable in temporary works design.

If requested by the Engineer, submit with the working drawings manufacturer's catalog data listing the weight of all construction equipment that will be supported on the temporary work. Show anticipated total settlements and/or deflections of falsework and forms on the working drawings. Include falsework footing settlements, joint take-up, and deflection of beams or girders.

As an option for the Contractor, overhang falsework hangers may be uniformly spaced, at a maximum of 36 inches, provided the following conditions are met:

Member Type (PCG)	Member Depth, (inches)	Max. Overhang Width, (inches)	Max. Slab Edge Thickness, (inches)	Max. Screenshot Wheel Weight, (lbs.)	Bracket Min. Vertical Leg Extension, (inches)
II	36	39	14	2000	26
III	45	42	14	2000	35
IV	54	45	14	2000	44
MBT	63	51	12	2000	50
MBT	72	55	12	1700	48

Overhang width is measured from the centerline of the girder to the edge of the deck slab. For Type II, III & IV prestressed concrete girders (PCG), 45-degree cast-in-place half hangers and rods must have a minimum safe working load of 6,000 lbs.

For MBT prestressed concrete girders, 45-degree angle holes for falsework hanger rods shall be cast through the girder top flange and located, measuring along the top of the member, 1'-2 1/2" from the edge of the top flange. Hanger hardware and rods must have a minimum safe working load of 6,000 lbs.

For link slabs, the top of girders directly beneath the link slab shall be free of overhang falsework attachments or other hardware. Submit calculations and working drawings for overhang falsework in the link slab region.

The overhang bracket provided for the diagonal leg shall have a minimum safe working load of 3,750 lbs. The vertical leg of the bracket shall extend to the point that the heel bears on the girder bottom flange, no closer than 4 inches from the bottom of the member. However, for 72-inch members, the heel of the bracket shall bear on the web, near the bottom flange transition.

Provide adequate overhang falsework and determine the appropriate adjustments for deck geometry, equipment, casting procedures and casting conditions.

If the optional overhang falsework spacing is used, indicate this on the falsework submittal and advise the girder producer of the proposed details. Failure to notify the Engineer of hanger type

ST-4

Project BR-0004

Beaufort County

and hanger spacing on prestressed concrete girder casting drawings may delay the approval of those drawings.

Falsework hangers that support concentrated loads and are installed at the edge of thin top flange concrete girders (such as bulb tee girders) shall be spaced so as not to exceed 75% of the manufacturer’s stated safe working load. Use of dual leg hangers (such as Meadow Burke HF-42 and HF-43) are not allowed on concrete girders with thin top flanges. Design the falsework and forms supporting deck slabs and overhangs on girder bridges so that there will be no differential settlement between the girders and the deck forms during placement of deck concrete.

When staged construction of the bridge deck is required, detail falsework and forms for screed and fluid concrete loads to be independent of any previous deck pour components when the mid-span girder deflection due to deck weight is greater than 3/4”.

Note on the working drawings any anchorages, connectors, inserts, steel sleeves or other such devices used as part of the falsework or formwork that remains in the permanent structure. If the plan notes indicate that the structure contains the necessary corrosion protection required for a Corrosive Site, epoxy coat, galvanize or metalize these devices. Electroplating will not be allowed. Any coating required by the Engineer will be considered incidental to the various pay items requiring temporary works.

Design falsework and formwork requiring submittals in accordance with the current edition of *AASHTO Guide Design Specifications for Bridge Temporary Works* except as noted herein.

(1) Wind Loads

Table 2.2 of Article 2.2.5.1 is modified to include wind velocities up to 110 mph. In addition, Table 2.2A is included to provide the maximum wind speeds by county in North Carolina.

Table 2.2 - Wind Pressure Values

Height Zone feet above ground	Pressure, lb/ft ² for Indicated Wind Velocity, mph				
	70	80	90	100	110
0 to 30	15	20	25	30	35
30 to 50	20	25	30	35	40
50 to 100	25	30	35	40	45
over 100	30	35	40	45	50

(2) Time of Removal

The following requirements replace those of Article 3.4.8.2.

Do not remove forms until the concrete has attained strengths required in Article 420-16 of the *Standard Specifications* and these Special Provisions.

ST-5

Project BR-0004

Beaufort County

Do not remove forms until the concrete has sufficient strength to prevent surface damage.

ST-6

Project BR-0004

Beaufort County

Table 2.2A - Steady State Maximum Wind Speeds by Counties in North Carolina

COUNTY	25 YR (mph)	COUNTY	25 YR (mph)	COUNTY	25 YR (mph)
Alamance	70	Franklin	70	Pamlico	100
Alexander	70	Gaston	70	Pasquotank	100
Alleghany	70	Gates	90	Pender	100
Anson	70	Graham	80	Perquimans	100
Ashe	70	Granville	70	Person	70
Avery	70	Greene	80	Pitt	90
Beaufort	100	Guilford	70	Polk	80
Bertie	90	Halifax	80	Randolph	70
Bladen	90	Harnett	70	Richmond	70
Brunswick	100	Haywood	80	Robeson	80
Buncombe	80	Henderson	80	Rockingham	70
Burke	70	Hertford	90	Rowan	70
Cabarrus	70	Hoke	70	Rutherford	70
Caldwell	70	Hyde	110	Sampson	90
Camden	100	Iredell	70	Scotland	70
Carteret	110	Jackson	80	Stanley	70
Caswell	70	Johnston	80	Stokes	70
Catawba	70	Jones	100	Surry	70
Cherokee	80	Lee	70	Swain	80
Chatham	70	Lenoir	90	Transylvania	80
Chowan	90	Lincoln	70	Tyrell	100
Clay	80	Macon	80	Union	70
Cleveland	70	Madison	80	Vance	70
Columbus	90	Martin	90	Wake	70
Craven	100	McDowell	70	Warren	70
Cumberland	80	Mecklenburg	70	Washington	100
Currituck	100	Mitchell	70	Watauga	70
Dare	110	Montgomery	70	Wayne	80
Davidson	70	Moore	70	Wilkes	70
Davie	70	Nash	80	Wilson	80
Duplin	90	New Hanover	100	Yadkin	70
Durham	70	Northampton	80	Yancey	70
Edgecombe	80	Onslow	100		
Forsyth	70	Orange	70		

ST-7

Project BR-0004

Beaufort County

(B) Review and Approval

The Engineer is responsible for the review and approval of temporary works' drawings.

Submit the working drawings sufficiently in advance of proposed use to allow for their review, revision (if needed), and approval without delay to the work.

The time period for review of the working drawings does not begin until complete drawings and design calculations, when required, are received by the Engineer.

Do not start construction of any temporary work for which working drawings are required until the drawings have been approved. Such approval does not relieve the Contractor of the responsibility for the accuracy and adequacy of the working drawings.

CONSTRUCTION REQUIREMENTS

All requirements of Section 420 of the *Standard Specifications* apply.

Construct temporary works in conformance with the approved working drawings. Ensure that the quality of materials and workmanship employed is consistent with that assumed in the design of the temporary works. Do not weld falsework members to any portion of the permanent structure unless approved. Show any welding to the permanent structure on the approved construction drawings.

Provide tell-tales attached to the forms and extending to the ground, or other means, for accurate measurement of falsework settlement. Make sure that the anticipated compressive settlement and/or deflection of falsework does not exceed 1 inch. For cast-in-place concrete structures, make sure that the calculated deflection of falsework flexural members does not exceed 1/240 of their span regardless of whether or not the deflection is compensated by camber strips.

(A) Maintenance and Inspection

Inspect and maintain the temporary work in an acceptable condition throughout the period of its use. Certify that the manufactured devices have been maintained in a condition to allow them to safely carry their rated loads. Clearly mark each piece so that its capacity can be readily determined at the job site.

Perform an in-depth inspection of an applicable portion(s) of the temporary works, in the presence of the Engineer, not more than 24 hours prior to the beginning of each concrete placement. Inspect other temporary works at least once a month to ensure that they are functioning properly. Have a North Carolina Registered Professional Engineer inspect the cofferdams, shoring, sheathing, support of excavation structures, and support systems for load tests prior to loading.

ST-8

Project BR-0004

Beaufort County

(B) Foundations

Determine the safe bearing capacity of the foundation material on which the supports for temporary works rest. If required by the Engineer, conduct load tests to verify proposed bearing capacity values that are marginal or in other high-risk situations.

The use of the foundation support values shown on the contract plans of the permanent structure is permitted if the foundations are on the same level and on the same soil as those of the permanent structure.

Allow for adequate site drainage or soil protection to prevent soil saturation and washout of the soil supporting the temporary works supports.

If piles are used, the estimation of capacities and later confirmation during construction using standard procedures based on the driving characteristics of the pile is permitted. If preferred, use load tests to confirm the estimated capacities; or, if required by the Engineer conduct load tests to verify bearing capacity values that are marginal or in other high risk situations.

The Engineer reviews and approves the proposed pile and soil bearing capacities.

REMOVAL

Unless otherwise permitted, remove and keep all temporary works upon completion of the work. Do not disturb or otherwise damage the finished work.

Remove temporary works in conformance with the contract documents. Remove them in such a manner as to permit the structure to uniformly and gradually take the stresses due to its own weight.

MEASUREMENT AND PAYMENT

Unless otherwise specified, *Falsework and Formwork* will not be directly measured.

Payment at the contract unit prices for the various pay items requiring temporary works will be full compensation for the above falsework and formwork.

ST-9

Project BR-0004

Beaufort County

SUBMITTAL OF WORKING DRAWINGS

(1-31-25)

GENERAL

Submit working drawings in accordance with Article 105-2 of the *Standard Specifications* and this Special Provision. For this Special Provision, “submittals” refers to only those listed in this Special Provision. The list of submittals contained herein does not represent a list of required submittals for the project. Submittals are only necessary for those items as required by the contract. Make submittals that are not specifically noted in this provision directly to the Engineer. Either the Structures Management Unit or the Geotechnical Engineering Unit or both units will jointly review submittals.

If a submittal contains variations from plan details or specifications or significantly affects project cost, field construction or operations, discuss the submittal with and submit all copies to the Engineer. State the reason for the proposed variation in the submittal. To minimize review time, make sure all submittals are complete when initially submitted. Provide a contact name and information with each submittal. Direct any questions regarding submittal requirements to the Engineer, Structures Management Unit contacts or the Geotechnical Engineering Unit contacts noted below.

To facilitate in-plant inspection by NCDOT and approval of working drawings, provide the name, address and telephone number of the facility where fabrication will actually be done if different than shown on the title block of the submitted working drawings. This includes, but is not limited to, precast concrete items, prestressed concrete items and fabricated steel or aluminum items.

ADDRESSES AND CONTACTS

For submittals to the Structures Management Unit, use the following addresses:

Via Email: SMU-wdr@ncdot.gov (do not cc SMU Working Drawings staff)

Via US mail:

Mr. D. N. Snoke, P. E.
State Structures Engineer
North Carolina Department
of Transportation
Structures Management Unit
1581 Mail Service Center
Raleigh, NC 27699-1581

Attention: Mr. J. L. Bolden, P. E.

Via other delivery service:

Mr. D. N. Snoke, P. E.
State Structures Engineer
North Carolina Department
of Transportation
Structures Management Unit
1000 Birch Ridge Drive
Raleigh, NC 27610

Attention: Mr. J. L. Bolden, P. E.

For submittals to the Geotechnical Engineering Unit, use the following addresses:

For projects in Divisions 1-7 (Eastern Regional Office):

Via Email: EastGeotechnicalSubmittal@ncdot.gov

ST-10

Project BR-0004

Beaufort County

Via US mail:

Mr. Thomas Santee, P. E.
Assistant State Geotechnical
Engineer – Eastern Region
North Carolina Department
of Transportation
Geotechnical Engineering Unit
Eastern Regional Office
1570 Mail Service Center
Raleigh, NC 27699-1570

Via other delivery service:

Mr. Thomas Santee, P. E.
Assistant State Geotechnical
Engineer – Eastern Region
North Carolina Department
of Transportation
Geotechnical Engineering Unit
Eastern Regional Office
3301 Jones Sausage Road, Suite 100
Garner, NC 27529

For projects in Divisions 8-14 (Western Regional Office):

Via Email: WestGeotechnicalSubmittal@ncdot.gov

Via US mail or other delivery service:

Mr. Eric Williams, P. E.
Assistant State Geotechnical
Engineer – Western Region
North Carolina Department
of Transportation
Geotechnical Engineering Unit
Western Regional Office
5253 Z Max Boulevard
Harrisburg, NC 28075

The status of the review of structure-related submittals sent to the Structures Management Unit can be viewed from the Unit’s website, via the “[Drawing Submittal Status](#)” link.

The status of the review of geotechnical-related submittals sent to the Geotechnical Engineering Unit can be viewed from the Unit’s website, via the “[Geotechnical Construction Submittals](#)” link.

Direct any questions concerning submittal review status, review comments or drawing markups to the following contacts:

Primary Structures Contact: James Bolden (919) 707 – 6408
jlbolden@ncdot.gov

Secondary Structures Contacts: Madonna Rorie (919) 707 – 6508
mlrorie@ncdot.gov

Eastern Regional Geotechnical Contact (Divisions 1-7):
Thomas Santee (984) 920-8901
EastGeotechnicalSubmittal@ncdot.gov

ST-11

Project BR-0004

Beaufort County

Western Regional Geotechnical Contact (Divisions 8-14):

Eric Williams (980)258-6400

WestGeotechnicalSubmittal@ncdot.gov**SUBMITTAL COPIES**

Furnish one complete copy of each submittal, including all attachments, to the Engineer. At the same time, submit a copy of the same complete submittal directly to the Structures Management Unit and/or the Geotechnical Engineering Unit as specified in the tables below.

The first table below covers “Structure Submittals.” The Engineer will receive review comments and drawing markups for these submittals from the Structures Management Unit. The second table in this section covers “Geotechnical Submittals.” The Engineer will receive review comments and drawing markups for these submittals from the Geotechnical Engineering Unit.

Unless otherwise required, submit one set of supporting calculations to either the Structures Management Unit or the Geotechnical Engineering Unit unless both units require submittal copies in which case submit a set of supporting calculations to each unit. Provide additional copies of any submittal as directed.

STRUCTURE SUBMITTALS

Submittal	Submittal Required by Structures Management Unit?	Submittal Required by Geotechnical Engineering Unit?	Contract Reference Requiring Submittal ¹
Arch Culvert Falsework	Y	N	Plan Note, SN Sheet & “Falsework and Formwork”
Box Culvert Falsework ⁷	Y	N	Plan Note, SN Sheet & “Falsework and Formwork”
Cofferdams	Y	Y	Article 410-4
Foam Joint Seals ⁶	Y	N	“Foam Joint Seals”
Expansion Joint Seals (hold down plate type with base angle)	Y	N	“Expansion Joint Seals”
Expansion Joint Seals (modular)	Y	N	“Modular Expansion Joint Seals”
Expansion Joint Seals (strip seals)	Y	N	“Strip Seal Expansion Joints”

ST-12

Project BR-0004

Beaufort County

Falsework & Forms ² (substructure)	Y	N	Article 420-3 & “Falsework and Formwork”
Falsework & Forms (superstructure)	Y	N	Article 420-3 & “Falsework and Formwork”
Girder Erection over Railroad	Y	N	Railroad Provisions
Maintenance and Protection of Traffic Beneath Proposed Structure	Y	N	“Maintenance and Protection of Traffic Beneath Proposed Structure at Station ____”
Metal Bridge Railing	Y	N	Plan Note
Metal Stay-in-Place Forms	Y	N	Article 420-3
Metalwork for Elastomeric Bearings ^{4,5}	Y	N	Article 1072-8
Miscellaneous Metalwork ^{4,5}	Y	N	Article 1072-8
Disc Bearings ⁴	Y	N	“Disc Bearings”
Overhead and Digital Message Signs (DMS) (metalwork and foundations)	Y	N	Applicable Provisions
Placement of Equipment on Structures (cranes, etc.)	Y	N	Article 420-20
Prestressed Concrete Box Beam (detensioning sequences) ³	Y	N	Article 1078-11
Precast Concrete Box Culverts	Y	N	“Optional Precast Reinforced Concrete Box Culvert at Station ____”
Prestressed Concrete Cored Slab (detensioning sequences) ³	Y	N	Article 1078-11
Prestressed Concrete Deck Panels	Y	N	Article 420-3
Prestressed Concrete Girder (strand elongation and detensioning sequences)	Y	N	Articles 1078-8 and 1078-11
Removal of Existing Structure over Railroad	Y	N	Railroad Provisions
	Y	N	Article 420-3

ST-13

Project BR-0004

Beaufort County

Revised Bridge Deck Plans (adaptation to prestressed deck panels)			
Revised Bridge Deck Plans (adaptation to modular expansion joint seals)	Y	N	“Modular Expansion Joint Seals”
Sound Barrier Wall (precast items)	Y	N	Article 1077-2 & “Sound Barrier Wall”
Sound Barrier Wall Steel Fabrication Plans ⁵	Y	N	Article 1072-8 & “Sound Barrier Wall”
Structural Steel ⁴	Y	N	Article 1072-8
Temporary Detour Structures	Y	Y	Article 400-3 & “Construction, Maintenance and Removal of Temporary Structure at Station _____”
TFE Expansion Bearings ⁴	Y	N	Article 1072-8

FOOTNOTES

- References are provided to help locate the part of the contract where the submittals are required. References in quotes refer to the provision by that name. Articles refer to the *Standard Specifications*.
- Submittals for these items are necessary only when required by a note on plans.
- Submittals for these items may not be required. A list of pre-approved sequences is available from the producer or the Materials & Tests Unit.
- The fabricator may submit these items directly to the Structures Management Unit.
- The two sets of preliminary submittals required by Article 1072-8 of the *Standard Specifications* are not required for these items.
- Submittals for Fabrication Drawings are not required. Submittals for Catalogue Cuts of Proposed Material are required. See Section 5.A of the referenced provision.
- Submittals are necessary only when the top slab thickness is 18” or greater.

ST-14

Project BR-0004

Beaufort County

GEOTECHNICAL SUBMITTALS

Submittal	Submittals Required by Geotechnical Engineering Unit	Submittals Required by Structures Management Unit	Contract Reference Requiring Submittal¹
Drilled Pier Construction Plans ²	Y	N	Subarticle 411-3(A)
Crosshole Sonic Logging (CSL) Reports ²	Y	N	Subarticle 411-5(A)(2)
Pile Driving Equipment Data Forms ^{2,3}	Y	N	Subarticle 450-3(D)(2)
Pile Driving Analyzer (PDA) Reports ²	Y	N	Subarticle 450-3(F)(3)
Retaining Walls ⁴	Y; drawings and calculations	Y; drawings	Applicable Provisions
Temporary Shoring ⁴	Y; drawings and calculations	Y; drawings	“Temporary Shoring” & “Temporary Soil Nail Walls”

FOOTNOTES

- References are provided to help locate the part of the contract where the submittals are required. References in quotes refer to the provision by that name. Subarticles refer to the *Standard Specifications*.
- Submit one hard copy of submittal to the Engineer. Submit a second copy of submittal electronically (PDF via email), US mail or other delivery service to the appropriate Geotechnical Engineering Unit regional office. Electronic submission is preferred.
- The Pile Driving Equipment Data Form is available from:
<https://connect.ncdot.gov/projects/construction/ConstManRefDocs/PILE%20DRIVING%20EQUIPMENT%20DATA%20FORM.pdf>
 See second page of form for submittal instructions.
- Electronic copy of submittal is required. See referenced provision.

ST-15

Project BR-0004

Beaufort County

CRANE SAFETY

(12-5-25)

GENERAL

Comply with the manufacturer specifications and limitations applicable to the operation of any and all cranes and derricks. Prime contractors, sub-contractors, and fully operated rental companies shall comply with the current Occupational Safety and Health Administration (OSHA) regulations.

Submit all items listed below to the Engineer prior to beginning crane operations. Changes in personnel or equipment must be reported to the Engineer and all applicable items listed below must be updated and submitted prior to continuing with crane operations.

CRANE SAFETY SUBMITTAL LIST

(A) **Competent Person:** Provide the name and qualifications of the “Competent Person” responsible for crane safety and lifting operations. The named competent person will have the responsibility and authority to stop any work activity due to safety concerns.

(B) **Riggers:** Provide the qualifications and experience of the persons responsible for rigging operations. Qualifications and experience should include, but not be limited to, weight calculations, center of gravity determinations, selection and inspection of sling and rigging equipment, and safe rigging practices.

(C) **Crane Inspections:** Inspection records for all cranes shall be current and readily accessible for review upon request.

(D) **Certifications:** Crane operators shall be certified by the National Commission for the Certification of Crane Operators (NCCCO) or the National Center for Construction Education and Research (NCCER). Other approved nationally accredited programs will be considered upon request. In addition, crane operators shall have a current CDL medical card. Submit a list of crane operator(s) and include current certification for each type of crane operated (small hydraulic, large hydraulic, small lattice, large lattice) and medical evaluations for each operator.

MEASUREMENT AND PAYMENT

No direct payment will be made for providing information, certifications and documentation required for *Crane Safety*.

ST-16

Project BR-0004

Beaufort County

GROUT FOR STRUCTURES

(12-1-17)

GENERAL

This Special Provision addresses grout for use in pile blockouts, grout pockets, shear keys, dowel holes and recesses for structures. This Special Provision does not apply to grout placed in post-tensioning ducts for bridge beams, girders, decks, end bent caps, or bent caps. Mix and place grout in accordance with the manufacturer's recommendations, the applicable sections of the *Standard Specifications* and this Special Provision.

MATERIAL REQUIREMENT

Unless otherwise noted on the plans, use a Type 3 Grout in accordance with Section 1003 of the *Standard Specifications*.

Initial setting time shall not be less than 10 minutes when tested in accordance with ASTM C266.

Construction loading and traffic loading shall not be allowed until the 3-day compressive strength is achieved.

SAMPLING AND PLACEMENT

Place and maintain components in final position until grout placement is complete and accepted. Concrete surfaces to receive grout shall be free of defective concrete, laitance, oil, grease, and other foreign matter. Saturate concrete surfaces with clean water and remove excess water prior to placing grout.

MEASUREMENT AND PAYMENT

No separate payment will be made for *Grout for Structures*. The cost of the material, equipment, labor, placement, and any incidentals necessary to complete the work shall be considered incidental to the structure item requiring grout.

ST-17

Project BR-0004

Beaufort County

SECURING OF VESSELS

(10-12-01)

GENERAL

Secure vessels in accordance with Section 107 of the *Standard Specifications* and the following provision.

When utilizing barges, tugboats or other vessels, take all necessary precautions to ensure that such vessels are securely anchored or moored when not in active operation. Take all necessary measures to ensure that the vessels are operated in a manner that avoids damage to or unnecessary contact with bridges and other highway structures and attachments. If severe weather conditions are anticipated or should be anticipated through reasonable monitoring of weather forecasts, take additional measures to protect bridges and other highway structures and attachments from extreme conditions. The Contractor is strictly liable for damages to any bridge or other highway structures or attachments caused by a vessel owned or controlled by the Contractor. The Contractor is also liable to third parties for property damages and loss of revenue caused by vessels under the Contractor's control.

MEASUREMENT AND PAYMENT

No separate payment will be made for *Securing of Vessels*.

ST-18

Project BR-0004

Beaufort County

**CONSTRUCTION, MAINTENANCE AND REMOVAL
OF TEMPORARY ACCESS AT STATION 23+50 -L-**

(12-12-13)

GENERAL

Construct, maintain, and remove the temporary access required to provide the working area necessary for construction of the new bridge, construction of the temporary detour structure, or for the removal of an existing bridge, as applicable. Temporary access may involve the use of a work bridge or other methods; however, all types of temporary access are required to meet the requirements of all permits, the *Standard Specifications*, and this Special Provision.

TEMPORARY WORK BRIDGE

At the contractor's option, construction of a temporary work bridge within the limits shown on the plans is permitted. The temporary work bridge shall have a minimum span length of 20 feet. Submit details of the temporary work bridge to the Engineer prior to constructing the work bridge to ensure conformance with the plans and all permits. Completely remove the temporary bridge prior to final acceptance or as otherwise required by the permits.

MEASUREMENT AND PAYMENT

Construction, Maintenance and Removal of Temporary Access at Station 23+50 -L- will be paid under the lump sum price bid for the above work, or other methods of access, including all material, work bridge components, equipment, tools, labor, disposal, and incidentals necessary to complete the work.

Payment will be made under:

Pay Item	Pay Unit
Construction, Maintenance and Removal of Temporary Access at Sta. 23+50 - L-	Lump Sum

ST-19

Project BR-0004

Beaufort County

THERMAL SPRAYED COATINGS (METALLIZATION)

(12-1-2017)

DESCRIPTION

Apply a thermal sprayed coating (TSC) and sealer to metal surfaces in accordance with the *Thermal Sprayed Coatings (Metallization) Program* and as specified herein when called for on the plans or by other Special Provisions. Use only Arc Sprayed application methods to apply TSC. The Engineer must approve other methods of application.

The *Thermal Sprayed Coatings (Metallization) Program* is available on the Materials and Tests Unit website.

QUALIFICATIONS

Only use NCDOT approved TSC Contractors meeting the requirements outlined in the *Thermal Sprayed Coatings (Metallization) Program*.

MATERIALS

1. Use only materials meeting the requirements of Section 7 of the *Thermal Sprayed Coatings (Metallization) Program*.

SURFACE PREPARATION AND TSC APPLICATION

2.

3. Surface preparation of TSC surfaces shall meet the requirements of Section 8 of the *Thermal Sprayed Coatings (Metallization) Program*. Apply TSC with the alloy to the thickness specified on the plans or as required by *Thermal Sprayed Coatings (Metallization) Program*.

INSPECTION AND TESTING

The TSC Contractor must conduct inspections and tests listed in the *Thermal Sprayed Coatings (Metallization) Program*.

REPAIRS

Perform all shop repairs in accordance with the procedures outlined in the *Thermal Sprayed Coatings (Metallization) Program*.

Repairs associated with field welding shall be made by removing the existing metallizing by blast or power tool cleaning. Affected areas shall be addressed as follows:

- For Marine Environments, incorporate a minimum surface preparation in accordance with SSPC SP-11 (Power Tool Cleaning to Bare Metal) and require an approved epoxy mastic coating applied in accordance with the manufacturer's recommendation. Apply a minimum of two (2) coats at a rate of 5-7 (WFT) per coat to the affected area.
- For Non-Marine Environments, incorporate a minimum surface preparation in accordance with SSPC SP-11 (Power Tool Cleaning to Bare Metal) and require an approved organic zinc-rich coating applied in accordance with the manufacturer's recommendation. Apply a minimum of two (2) coats at a rate of 5-7 (WFT) per coat to the affected area.

ST-20

Project BR-0004

Beaufort County

- (1) Minor localized areas less than or equal to 0.1 ft^2 with exposed substrate shall be repaired as outlined above for marine and non-marine environments.
- (2) Large localized areas greater than 0.1 ft^2 with exposed substrate shall require the Contractor to submit a detailed repair procedure to the Engineer for review and approval.
- (3) Repair methods for areas where the substrate has not been exposed shall be mutually agreed upon between the Contractor and TSC Contractor as approved by the Engineer.

TWELVE MONTH OBSERVATION PERIOD

All TSC materials applied under the *Thermal Sprayed Coatings (Metallization) Program* shall be evaluated twelve (12) months after project acceptance for defective materials and workmanship.

MEASUREMENT AND PAYMENT

The contract price bid for the metal component to which the TSC is applied will be full compensation for the thermal sprayed coating.

ST-21

Project BR-0004

Beaufort County

STRIP SEAL EXPANSION JOINTS

(06-25-20)

GENERAL

This Special Provision covers furnishing and installing strip seal expansion joints as shown on the contract drawings and in accordance with this Special Provision, the *Standard Specifications* and the manufacturer's recommendation. All materials, labor, equipment, and incidentals necessary for proper installation of the strip seal expansion joints are included.

MATERIALS

Provide strip seal expansion joints capable of accommodating a total movement measured parallel to the centerline of the roadway as shown on plans. The components of the expansion joint include steel retainer rails and a neoprene seal gland.

The steel retainer rails shall consist of a "P" shape profile configuration with anchor studs welded to the concrete face. The rails shall have a minimum height of 8 inches, a minimum thickness of ½ inch and a maximum top surface (at the riding surface) width of 2 inches. Use AASHTO M270 Grade 36 or Grade 50 steel for the steel retainer rails.

The neoprene gland shall be extruded synthetic rubber with virgin polychloroprene as the only polymer. The gland manufacturer shall provide a Type 4 certification, in accordance with the *Standard Specifications*, attesting the gland has been tested and meets the following minimum properties:

PHYSICAL PROPERTY	TEST METHOD	REQUIREMENTS
Tensile Strength, psi (min.)	ASTM D412	2,000
Elongation at break, % (min.)	ASTM D412	250
Hardness, Type A durometer, points	ASTM D2240 Modified	60 ± 10
Oven aging, 70h @ 212°F Tensile strength, % change (max.) Elongation, % change (max.) Hardness, points change (max.)	ASTM D573	-20 -20 0 to +10
Oil Swell, ASTM Oil No. 3, 70h @ 212°F Weight change, % (max.)	ASTM D471	45
Ozone resistance 20% strain, 300 pphm in air 70h @ 104°F	ASTM D1149 Modified	No cracks
Low temperature stiffening, 7 days @ 14°F Hardness, Type A durometer, points change	ASTM D2240	0 to +15
Compression Set, 70h @ 212°F (max.)	ASTM D395 Method B (modified)	40%

ST-22

Project BR-0004

Beaufort County

SHOP DRAWINGS

Submit a set of complete shop drawings to the Engineer via email for review, comments and acceptance and carbon copy (cc) the Structures Management Unit Working Drawing Review Group (SMU-wdr@ncdot.gov). Send the drawings well in advance of the scheduled installation time for the strip seal expansion joint rail. Prior to submitting the shop drawings, have someone, other than the draftsman who prepares the drawings, check all detailed drawings and include the signatures of both the draftsman and checker on each sheet of the drawings. The Engineer returns unchecked drawings to the Contractor.

Steel retainer rails shall consist of one-piece construction including upturns. Welding two (2) or more components to obtain the required cross-sectional shape is not permitted. Show all dimensions, anchor stud locations, welded splice details, splice locations and any other details or data necessary to fabricate the joint on the shop drawings. Include the joint model number and joint movement range. Draw all details to scale. Identify, in detail, welding procedures to be performed in fabricating the joint. As a minimum, also show the following on the drawings:

- (A) All field splice locations. Steel retainer rail field splices are only permitted at crown points, locations with abrupt changes in the deck slab cross slope, and at travel lane lines. Splices within travel lanes are not permitted and splicing on edge lines is not required. For the location of travel lane markings at the strip seal expansion joint, see the structure plans. At the field splice locations, locate the horizontal stud anchors 3 inches from the centerline of the splice.
- (B) Details of the shipping device for the steel retainer rail assemblies. Ensure the device is capable of resisting shipping and handling forces without causing damage to the steel retainer rail assemblies or metallized coating.
- (C) The method of supporting steel retainer rails horizontally and vertically during joint installation and placement of concrete to ensure stability and proper alignment. Ensure the method is capable of resisting construction forces without causing damage to the steel retainer rail assemblies or metallized coating and are adjustable to account for variable temperature settings. Place supports near field splices of steel retainer rails to ensure that splices are straight and even.
- (D) The proposed procedure to correct for the effects of beam movement and rotation when setting width of joint opening.
- (E) The proposed installation procedure including the sequence and suggested direction of the concrete pour(s).
- (F) The proposed mechanism to allow joint translation after the deck pour.
- (G) A section through the joint detail showing horizontal offset dimensions of the steel retainer rails from the centerline of the joint. This detail is required when the vertical face of the joint opening is not perpendicular to the roadway surface (e.g. when the roadway grade is significant).

FABRICATION

Fabricate the strip seal joint components in accordance with the approved shop drawings and the plans.

Splice sections of steel retainer rail in the shop to obtain required lengths. Do not use short pieces of steel retainer rail less than 6 feet long unless required at curbs, sidewalks or staged construction

ST-23

Project BR-0004

Beaufort County

locations. Splices in an individual steel retainer rail are only permitted where a construction joint is specifically required by the plans, joint segment length exceeds 50 feet, or approved by the Engineer in writing.

At splice locations where changes in deck slab cross slope occur, cut the ends of steel retainer rails parallel to the bridge centerline for skews less than 80° and greater than 100°.

Provide a neoprene gland that is compatible with the steel retainer rail. Produce a single continuous neoprene gland for the entire length of the joint. When necessary, only vulcanized splicing of the gland in the shop is permitted. Ensure the convolution(s) of the gland does not project above the top of the steel retainer rails when the ambient temperature results in the minimum joint opening.

SHIPMENT

Bolt the steel retainer rails together in the shop to form matching pairs. Clearly mark each pair to identify where they are to be placed. Ship the neoprene gland(s) together with the steel retainer rail(s) and clearly mark them to identify where they are to be placed.

INSTALLATION

Install the strip seal expansion joint in accordance with the plan details, this Special Provision, the *Standard Specifications*, and the manufacturer's recommended installation procedures. Have a manufacturer's representative present during installation of the joint.

Install the steel retainer rail assemblies at proper grade and alignment. See contract drawings for width of joint opening.

Bolt, weld or clamp steel retainer rail assemblies in position using temporary or sacrificial brackets as required. Do not use temporary or sacrificial support brackets, bolts, clamps, etc. between the faces of the steel retainer rails. Do not weld within two (2) inches of steel retainer rail surfaces exposed in the completed structure. Do not weld strip seal expansion joint components to reinforcing steel or structural steel.

For staged construction, install steel retainer rail assemblies in a given subsequent stage to align with those installed in an adjacent prior stage after deflection and rotation due to deck casting of adjoining spans has occurred.

Protect metalized steel retainer rail assemblies during screeding operations per the manufacturer's recommendations. Provide temporary blocking material in the steel retainer rail seal cavities to prevent concrete intrusion during deck pour and finishing.

Loosen any temporary or sacrificial support brackets, bolts, clamps, etc. that span across the joint after initial set of concrete, but not more than two hours after conclusion of concrete placement.

Install the neoprene gland after completion of deck casting. Use a single continuous neoprene gland for the entire length of the joint. Field splicing of the neoprene gland is not permitted. Remove all joint form material and blocking material prior to installing the gland. Field install the gland in accordance with manufacturer's recommendations. Thoroughly coat all contact surfaces between the gland and the steel retainer rail seal cavities with an adhesive lubricant before setting

ST-24

Project BR-0004

Beaufort County

the gland in place. Use lubricant adhesive that conforms to ASTM D4070 and is compatible with manufacture's strip seal expansion joint to attach neoprene gland to the steel retainer rails.

INSPECTION

The Engineer inspects the joint system for proper alignment and proper stud placement and attachment. If any aspect of the strip seal expansion joint is deemed unacceptable, make the necessary corrections.

When concrete is cast, use a non-aluminum, 10 foot, true-to-line straight-edge to check and grade the top of the slab on each side of the joint to ensure smooth transition between spans.

(A) Watertight Integrity Test

- (1) Upon completion of each strip seal expansion joint, perform a watertight integrity test on the top surface to detect any leakage. Cover the roadway section of the joint from curb to curb, or barrier rail to barrier rail, with water, either ponded or flowing, not less than 1 inch above the roadway surface at all points. Block sidewalk sections and secure an unnozzled water hose delivering approximately 1 gallon of water per minute to the inside face of the bridge railing, trained in a downward position about 6 inches above the sidewalk, such that there is continuous flow of water across the sidewalk and down the curb face of the joint.
- (2) Maintain the ponding or flowing of water on the roadway and continuous flow across sidewalks and curbs for a period of 5 hours. At the conclusion of the test, the underside of the joint is closely examined for leakage. The strip seal expansion joint is considered watertight if no obvious wetness is visible on the Engineer's finger after touching a number of underdeck areas. Damp concrete that does not impart wetness to the finger is not considered a sign of leakage.
- (3) If the joint system leaks, locate the place(s) of leakage and take any repair measures necessary to stop the leakage at no additional cost to the Department. Use repair measures recommended by the manufacturer and approved by the Engineer prior to beginning corrective work.
- (4) If measures to eliminate leakage are taken, perform a subsequent watertight integrity test subject to the same conditions as the original test. Subsequent tests carry the same responsibility as the original test and are performed at no additional cost to the Department.

MEASUREMENT AND PAYMENT

Strip Seal Expansion Joints will be paid for at the lump sum contract price. Payment will be full compensation for furnishing all material, including any steel accessory plates for sidewalks, medians and rails, labor, tools, and incidentals necessary for installing the strip seal expansion joint in place and including all materials, labor, tools and incidentals for performing the original watertight integrity test.

Payment will be made under:

Pay Item**Pay Unit**

ST-25

Project BR-0004

Beaufort County

Strip Seal Expansion Joints

Lump Sum

ST-26

Project BR-0004

Beaufort County

ASBESTOS ASSESSMENT**(11-30-23)****INSPECTION FOR ASBESTOS CONTAINING MATERIAL**

Prior to conducting bridge demolition or renovation activities, the Contractor shall thoroughly inspect the bridge or affected components for the presence of asbestos containing material (ACM) using a firm prequalified by NCDOT to perform asbestos surveys. The inspection must be performed by a N.C. accredited asbestos inspector with experience inspecting bridges or other industrial structures. The N.C. accredited asbestos inspector must conduct a thorough inspection, identifying all asbestos-containing material as required by the Environmental Protection Agency National Emission Standards for Hazardous Air Pollutants (NESHAP) Code of Federal Regulations (CFR) 40 CFR, Part 61, Subpart M.

The Contractor shall submit an inspection report to the Engineer, which at a minimum must include information required in 40 CFR 763.85 (a)(4) vi)(A)-(E), as well as a project location map, photos of existing structure, the date of inspection and the name, N.C. accreditation number, and signature of the N.C. accredited asbestos inspector who performed the inspection and completed the report. The cover sheet of the report shall include project identification information. Place the following notes on the cover sheet of the report and check the appropriate box:

- ACM was found
 ACM was not found

REMOVAL AND DISPOSAL OF ASBESTOS CONTAINING MATERIAL

If ACM is found, notify the Engineer. Compensation for removal and disposal of ACM is considered extra work in accordance with Article 104-7 of the *Standard Specifications*.

An Asbestos Removal Permit must be obtained from the Health Hazards Control Unit (HHCU) of the N.C. Department of Health & Human Services, Division of Public Health, if more than 35 cubic feet, 160 square feet, or 260 linear feet of regulated ACM (RACM) is to be removed from a structure and this work must be completed by a contractor prequalified by NCDOT to perform asbestos abatement. RACM is defined in 40 CFR, Part 61, Subpart M. Note: 40 CFR 763.85 (a)(4) vi)(D) defines ACM as surfacing, TSI and Miscellaneous which does not meet the NESHAP RACM.

DEMOLITION NOTIFICATION

Even if no ACM is found (or if quantities are less than those required for a permit), a Demolition Notification (DHHS-3768) must be submitted to the HHCU. Notifications and Asbestos Permit applications require an original signature and must be submitted to the HHCU 10 working days prior to beginning demolition activities. The 10 working day period starts based on the post-marked date or date of hand delivery. Demolition that does not begin as originally notified requires submission of a separate revision form HHCU 3768-R to HHCU. Reference the North Carolina Administrative Code, Chapter 10A, Subchapter 41C, Article .0605 for directives on revision submissions.

Contact Information

ST-27

Project BR-0004

Beaufort County

Health Hazards Control Unit (HHCU)
N.C. Department of Health and Human Services
1912 Mail Service Center
Raleigh, NC 27699-1912
Telephone: (919) 707-5950
Fax: (919) 870-4808

SPECIAL CONSIDERATIONS

Buncombe, Forsyth, and Mecklenburg counties also have asbestos permitting and NESHAP requirements must be followed. For projects involving permitted RACM removals, both the applicable county and the state (HHCU) must be notified.

For demolitions with no RACM, only the local environmental agencies must be notified. Contact information is as follows:

Buncombe County

WNC Regional Air Pollution Control Agency
49 Mt. Carmel Road
Asheville, NC 28806
(828) 250-6777

Forsyth County

Environmental Affairs Department
537 N. Spruce Street
Winston-Salem, NC 27101
(336) 703-2440

Mecklenburg County

Land Use and Environmental Services Agency
Mecklenburg Air Quality
700 N. Tryon Street
Charlotte, NC 28202
(704) 336-5430

ADDITIONAL INFORMATION

Additional information may be found on N.C. asbestos rules, regulations, procedures, and N.C. accredited inspectors, as well as associated forms for demolition notifications and asbestos permit applications at the N.C. Asbestos Hazard Management Program website:

<https://epi.dph.ncdhhs.gov/asbestos/ahmp.html>

ST-28

Project BR-0004

Beaufort County

MEASUREMENT AND PAYMENT

Asbestos Assessment Payment will be paid at the lump sum contract unit price and will be full compensation for all asbestos inspections, reports, permitting and notifications.

Payment will be made under:

Pay Item	Pay Unit
Asbestos Assessment	Lump Sum

PROJECT SPECIAL PROVISION

(10-18-95) (Rev. 10-15-24)

Z-1

PERMITS

The Contractor's attention is directed to the following permits, which have been issued to the Department of Transportation by the authority granting the permit.

<u>PERMIT</u>	<u>AUTHORITY GRANTING THE PERMIT</u>
Dredge and Fill and/or Work in Navigable Waters (404)	U. S. Army Corps of Engineers
Water Quality (401)	Division of Water Resources, DEQ State of North Carolina
Buffer Certification	Division of Water Resources, DEQ State of North Carolina
State Dredge and Fill and/or CAMA	Division of Coastal Management, DEQ State of North Carolina
Navigation	U. S. Coast Guard

The Contractor shall comply with all applicable permit conditions during construction of this project.

Agents of the permitting authority will periodically inspect the project for adherence to the permits.

The Contractor's attention is also directed to Articles 107-10 and 107-13 of the *Standard Specifications* and the following:

Should the Contractor propose to utilize construction methods (such as temporary structures or fill in waters and/or wetlands for haul roads, work platforms, cofferdams, etc.) not specifically identified in the permit (individual, general, or nationwide) authorizing the project it shall be the Contractor's responsibility to coordinate with the Engineer to determine what, if any, additional permit action is required. The Contractor shall also be responsible for initiating the request for the authorization of such construction method by the permitting agency. The request shall be submitted through the Engineer. The Contractor shall not utilize the construction method until it is approved by the permitting agency. The request normally takes approximately 60 days to process; however, no extensions of time or additional compensation will be granted for delays resulting from the Contractor's request for approval of construction methods not specifically identified in the permit.

Where construction moratoriums are contained in a permit condition which restricts the Contractor's activities to certain times of the year, those moratoriums will apply only to the portions of the work taking place in the restricted waters, wetlands or buffer zones, provided that activities outside those areas is done in such a manner as to not affect the restricted waters, wetlands or buffer zones.



STATE OF NORTH CAROLINA
DEPARTMENT OF TRANSPORTATION

JOSH STEIN
GOVERNOR

DANIEL H. JOHNSON
SECRETARY

March 5, 2026

Updated March 25, 2026

MEMORANDUM TO: Division Construction Unit
Contract Standards and Development Unit

FROM: Cathrine Hossack, PE, Project Engineer
Division 2 Project Development Unit

SUBJECT: Environmental Permits for the Replacement of Bridge No. 66 on US 264
over the Pungo River in Beaufort and Hyde Counties, Division 2. STIP
BR-0004.

Please find enclosed the following permits for this project:

Agency	Permit Type	Permit Expiration
US Army Corps of Engineers	Section 404 Clean Water Act General Permit 50	May 25, 2030
NC Division of Water Resources	Section 401 Clean Water Act Individual Water Quality Certification	May 25, 2030
NC Division of Water Resources	Riparian Buffer Rules Tar-Pamlico Riparian Buffer Authorization	March 4, 2031
NC Division of Coastal Management	Coastal Area Management Act Major Development Permit No. 78-25	No Expiration
US Coast Guard	General Bridge Act Advance Approval	April 25, 2029

Work is authorized by the above referenced permits provided it is accomplished in strict accordance with the permitted plans. The Division Environmental Office must be consulted if any deviation from the permit(s) is required.



DEPARTMENT OF THE ARMY
U.S. ARMY CORPS OF ENGINEERS, WILMINGTON DISTRICT
WRDA/TRANSPORTATION BRANCH
2407 WEST 5TH STREET
WASHINGTON NORTH CAROLINA 27889

February 6, 2026

Regulatory Program/Division
SAW-2024-00712

Sent Via Email: cahossackmeyer@ncdot.gov

Cathrine Hossack Meyer
NCDOT
1037 W.H. Smith Blvd.
Greenville, NC 27835

Dear Ms. Hossack Meyer:

This letter is in response to the application you submitted to the Wilmington District, WRDA/Transportation Branch on January 30, 2026, for a Department of the Army general permit verification. This project has been assigned the file number SAW-2024-00712 and is known as Bridge 66 over the Pungo River. This file number should be referenced in all correspondence concerning this project.

A review of the information provided indicates that the proposed work would include replacement of Bridge 66 over the Pungo River. The project area for this determination includes a 5 acre which is illustrated on the enclosed site plans/maps. The project/review area is located on US-264 over the Pungo River, at Latitude 35.571580 and Longitude -76.501470; in Scranton, Hyde County, North Carolina.

We have determined that the proposed work is authorized by RGP-50 pursuant to authorities under Section 10 of the Rivers and Harbors Act of 1899 (33 U.S.C. § 403) and Section 404 of the Clean Water Act (33 U.S.C § 1344). The proposed work must be accomplished in strict accordance with the enclosed general permit conditions, any regional conditions, the special conditions listed in this letter, the application materials, and the enclosed plans. If the extent of the project area and/or nature of the authorized impacts to waters are modified, a revised application must be submitted to this office for written approval before work is initiated. Any deviation from the terms and conditions of the permit, or your submitted plans, may subject the permittee to enforcement action.

This verification is valid until May 25, 2030, unless the subject general permit(s) is suspended, revoked, or is modified prior to that date such that the activity no longer complies with the terms and conditions of the general permit.

Project Specific Special Conditions:

1. Work Limits: All work authorized by this permit shall be performed in strict compliance with the attached permit plans dated **January 29, 2025 and reverified on February 5, 2026**, which are a part of this permit. The Permittee shall ensure that the construction design plans for this project do not deviate from the permit plans attached to this authorization. Any modification to the attached permit plans must be approved by the U.S. Army Corps of Engineers (Corps) prior to any active construction in waters or wetlands.

2. Permit Distribution: The Permittee shall require its contractors and/or agents to comply with the terms and conditions of this permit in the construction and maintenance of this project and shall provide each of its contractors and/or agents associated with the construction or maintenance of this project with a copy of this permit. A copy of this permit, including all conditions and drawings shall be available at the project site during construction and maintenance of this project.

3. Reporting Address: All reports, documentation, and correspondence required by the conditions of this permit shall be submitted to the following: U.S. Army Corps of Engineers, Wilmington District, Washington Regulatory Field Office, Attn: Thomas Steffens, 2405 West 5th St. Washington, NC 27889 or Thomas.a.steffens@usace.army.mil. The Permittee shall reference the following permit number, **SAW-2024-00712** on all submittals.

4. Reporting Violations: Violation of these permit conditions or violation of Section 404 of the Clean Water Act or Section 10 of the Rivers and Harbors Act shall be reported to the Corps in writing and by telephone at: 910-251-4615 within 24 hours of the Permittee's discovery of the violation.

5. Endangered Species Act: The Permittee shall implement all necessary measures to ensure the authorized activity does not kill, injure, capture, harass, or otherwise harm any federally listed threatened or endangered species. While accomplishing the authorized work, if the Permittee discovers or observes an injured or dead threatened or endangered species, the U.S. Army Corps of Engineers, Wilmington District, Washington Field Office, Attn: Thomas Steffens at 910-251-4615 will be immediately notified to initiate the required Federal coordination.

This project is subject to the Programmatic Biological Opinion (PBO) titled, "NCDOT Program Effects on the Northern Long-eared Bat in Divisions 1-8", dated November 6, 2020. The PBO contains conservation measures that the permittee has agreed to comply with, and a special condition to this effect would be included in any verification letter that may be issued for this project. "May affect, likely to adversely affect" (MA-LAA) is the programmatic determination for effects to the NLEB for NCDOT projects in Divisions 1-8. In the PBO, the USFWS documented agreement with this MA-LAA determination for the NLEB and the consultation process is complete for this species for NCDOT projects in Divisions 1-8.

The U.S. Fish and Wildlife Service's (USFWS's) Programmatic Conference Opinion (PCO) titled "NCDOT Program Effects on the Tricolored Bat in Divisions 1-8", dated November 20, 2023, contains mandatory terms and conditions to implement the reasonable and prudent measures that are associated with "incidental take" that are specified in the PCO. Your authorization under this Corps permit is conditional upon your compliance with all the mandatory terms and conditions associated with incidental take of the PCO, which terms and conditions are incorporated by reference in this permit. Failure to comply with the terms and conditions associated with incidental take of the PCO, where a take of the listed species occurs, would constitute an unauthorized take, and it would also constitute non-compliance with your Corps permit. The USFWS is the appropriate authority to determine compliance with the terms and conditions of its PCO, and with the ESA.

6. Mitigation: The Permittee shall fully implement the compensatory mitigation plan, entitled "Onsite Wetland Mitigation Plan Bridge 66 on US-264 over Pungo River", dated January 20, 2025, for the unavoidable impacts to 0.570 acres of coastal marsh wetlands and 0.350 acres of non-tidal riparian wetlands. Activities prescribed by this plan shall be initiated prior to, or concurrently with, commencement of any construction activities within jurisdictional areas authorized by this permit. The Permittee shall re-establish 0.680 acres of coastal marsh wetlands and 0.420 acres of non-tidal riparian wetlands in accordance with the plan and with the following conditions:

- 1) The Permittee, NCDOT is the party responsible for the implementation, performance and long-term management of the compensatory mitigation project.
- 2) Any changes or modifications to your mitigation plan shall be first approved by the Corps.
- 3) The mitigation area is located within the NCDOT Right of Way currently owned or to be acquired for the project. The site will be managed to prohibit all uses inconsistent with its use as mitigation property, including any activity that would materially alter the biological integrity or functional and educational value of the site, consistent with the mitigation plan.

The site will be placed in the Environmental Analysis Unit (EAU) mitigation geodatabase. It will be monitored for five years with annual reports posted to the EAU website and presented to agency representatives during the annual monitoring review meeting. After closeout, the site will be placed in the NCDOT Stewardship Program for long term management and protection.

This general permit verification and any associated authorizations does not preclude the necessity to obtain any other Federal, State, or local permits, licenses, and/or certifications, which may be required.

If you have any questions related to this verification or have issues accessing documents referenced in this letter, please contact Thomas Steffens, Project Manager of the WRDA/Transportation Branch at 910-251-4615, by mail at the above address, or by email at thomas.a.steffens@usace.army.mil. Please take a moment to complete our customer satisfaction survey located at <https://regulatory.ops.usace.army.mil/customer-service-survey/>.

Sincerely,

A handwritten signature in black ink that reads "M. Scott Jones". The signature is written in a cursive style with a prominent red flourish at the end of the word "Jones".

M. Scott Jones, PWS
WRDA/Transportation Branch

Enclosures

Cc (w/enclosures):
Chris Rivenbark, RK&K (via crivenbark@rkk.com)

**DEPARTMENT OF THE ARMY
Wilmington District, Corps of Engineers
69 Darlington Avenue
Wilmington, North Carolina 28403-1343**

**Regional General Permit No. SAW-2019-02350 (RGP 50)
Name of Permittee: North Carolina Department of Transportation
Effective Date: May 26, 2025
Expiration Date: May 25, 2030**

**DEPARTMENT OF THE ARMY
REGIONAL GENERAL PERMIT**

A regional general permit (RGP) to perform work in or affecting navigable waters of the United States and waters of the United States, upon recommendation of the Chief of Engineers, pursuant to Section 10 of the Rivers and Harbors Act of March 3, 1899 (33 U.S.C. 403), and Section 404 of the Clean Water Act (33 U.S.C. 1344), is hereby issued by authority of the Secretary of the Army by the

District Commander
U.S. Army Engineer District, Wilmington
Corps of Engineers
69 Darlington Avenue
Wilmington, North Carolina 28403-1343

TO AUTHORIZE THE DISCHARGE OF DREDGED OR FILL MATERIAL IN WATERS OF THE UNITED STATES (U.S.), INCLUDING WETLANDS, ASSOCIATED WITH CERTAIN MAINTENANCE, REPAIR, AND CONSTRUCTION PROJECTS CONDUCTED BY THE VARIOUS DIVISIONS OF THE NORTH CAROLINA DEPARTMENT OF TRANSPORTATION (NCDOT), INCLUDING THE NCDOT DIVISION OF HIGHWAYS, RAIL, BICYCLE/PEDESTRIAN, ETC.

Activities authorized by this RGP:

- a. (1) Road widening, and/or (2) construction, maintenance, replacement, and/or repair of bridges. For bridge projects, work can include the approaches.
- b. (1) Improvement of interchanges or intersections, or (2) construction of interchanges or intersections over, or on, existing roads.

Full descriptions/terms of “a.” and “b.”:

a. (1) Road widening, and/or (2) construction, maintenance, and/or repair of bridges. For bridge projects, work can include the approaches.

Permanent impacts that result in a loss of waters of the U.S., excluding stream relocation(s), must be less than or equal to 500 linear feet (lf) of stream and/or one (1) acre of wetland/open water for each single and complete linear project.

Single and complete linear project. As noted in 33 CFR 330.2(i), for linear projects, the “single and complete project” (i.e., single and complete crossing) will apply to each crossing of a separate water of the U.S. (i.e., single waterbody) at that location; except that for linear projects crossing a single waterbody several times at separate and distant locations, each crossing is considered a single and complete project. However, individual channels in a braided stream or river, or individual arms of a large, irregularly-shaped wetland or lake, etc., are not separate waterbodies and crossing of such features cannot be considered separately.

This RGP can be used for those projects where a bridge is replaced with a culvert if the U.S. Army Corps of Engineers (Corps) determines that (1) NCDOT has provided sufficient justification for replacing a bridge with a culvert and (2) NCDOT has adequately demonstrated that the bridge to culvert replacement project would have no more than minimal individual and cumulative adverse effects to the aquatic environment. Note that all comments from commenting and/or other permitting agencies would be considered in the Corps’ evaluation of a bridge to culvert project.

Activities authorized under “a.” may include a small amount of new location roadway provided that the Corps determines that NCDOT has sufficiently demonstrated that (1) the new location roadway is necessary for safety, access, or other compelling reasons and (2) the length of the new location roadway is minimal and would not change the nature of the project from a widening or bridge project under “a.” to a new location roadway project.

For road widening or bridge projects - to ensure that the Corps has the necessary information to evaluate proposed impacts and effects to waters of the U.S. for a specific transportation project prior to making a permit decision, NCDOT’s Preconstruction Notification (PCN) for a specific transportation project must include a description of all impacts to waters of the U.S. that would result from (1) the transportation facility itself AND (2) all other impacts to waters of the U.S. that would be caused by, or result from, construction of the transportation facility; this includes impacts to waters of the U.S. from any associated, non-transportation facilities, such as utility infrastructure, driveway relocations, etc. NCDOT shall also detail in the PCN whether or not another entity (i.e., other than NCDOT) will apply for those non-transportation facility impacts to waters of the

U.S. separately. If NCDOT will apply for both the transportation AND non-transportation facility impacts to waters of the U.S. for a specific project (or some but not all of the non-transportation facilities), NCDOT will provide the required information for both the transportation AND the non-transportation facility impacts in the project summary and the impact table sections of the PCN. In those situations where NCDOT applies for and receives authorization to impact waters of the U.S. for both the transportation facility AND the non-transportation facilities for a specific project (or some but not all of the non-transportation facilities), NCDOT will be the responsible party/permittee for all permit-related matters for those impacts to waters of the U.S. to include the responsibility for permit compliance and obtaining any required compensatory mitigation.

Also authorized under “a”: (1) stream relocation(s) and (2) temporary impacts, such as those from temporary structures, fills, dewatering, and other work necessary to conduct the activities listed under “a”. Stream relocation(s) and temporary impacts will be evaluated independently and are not limited to the permanent loss limits of 500 lf of stream and/or 1 acre of wetland/open water (i.e., stream relocations and/or temporary impacts do not factor into these limits) for each single and complete linear project; however, if the Corps determines that the proposed stream relocation(s) and/or temporary impacts are of such magnitude that they cannot be authorized under this section (“a”) of RGP 50, even if the permanent losses from road widening, and/or construction, maintenance, and repair of bridges do not exceed the impact limits for this section (“a”) of RGP 50, an Individual Permit will be required.

If the Corps determines, on a case-by-case basis, that the concerns for the aquatic environment so indicate, he/she may exercise discretionary authority to override this RGP and require an Individual Permit.

b. (1) Improvement of interchanges or intersections, or (2) construction of interchanges or intersections, over or, on existing roads.

For activities authorized under “b”, the limits for permanent impacts that result in a loss of waters of the U.S. depend on the location of the impacts, as described below:

- In the coastal plain of North Carolina (both inner coastal plain and outer coastal plain) - permanent impacts that result in a loss of waters of the U.S., excluding stream relocation(s), must be less than or equal to 1,000 lf of stream and/or 3 acres of wetland/open water for the entire interchange or intersection project.
- All other areas of North Carolina - permanent impacts that result in a loss of waters of the U.S., excluding stream relocation(s), must be less than or equal to 1,000 lf of stream and/or 2 acres of wetland/open water for the entire interchange or intersection project.

Coastal plain – See http://saw-reg.usace.army.mil/JD/LRRs_PandT.pdf for Land Resource Areas LRRP (inner coastal plain) and LRRT (outer coastal plain).

P-10

When proposed impacts to waters of the U.S. are located both inside AND outside of the coastal plain, the Corps will determine, based on the location(s) of proposed impacts to waters of the U.S., if a project is a “coastal plain project”.

Single and complete project. For permitting purposes, each interchange or intersection is considered to be one single and complete project. For example, an interchange project cannot result in a permanent loss (excluding stream relocation), of (1) greater than 1,000 lf of stream and/or 3 acres of wetland/open water in the coastal plain OR (2) greater than 1,000 lf of stream and/or 2 acres of wetland/open water in all other areas of North Carolina.

Approach fills may be considered to be part of an interchange or intersection project if the Corps determines that inclusion of these areas meet the terms of this section (“b”) of RGP 50. It is understood that approach fills may be on new location. Early coordination with the Corps is encouraged.

Intersections, regardless of the mode of transportation (e.g., railroad, other roadways, etc.), may be at grade or grade separated if the Corps determines that the project would meet the terms of this section (“b”) of RGP 50. Early coordination with the Corps is encouraged.

For interchange or intersection projects - to ensure that the Corps has the necessary information to evaluate proposed impacts and effects to waters of the U.S. for a specific transportation project prior to making a permit decision, NCDOT’s Preconstruction Notification (PCN) for a specific transportation project must include a description of all impacts to waters of the U.S. that would result from (1) the transportation facility itself AND (2) all other impacts to waters of the U.S. that would be caused by, or result from, construction of the transportation facility; this includes impacts to waters of the U.S. from any associated, non-transportation facilities, such as utility infrastructure, driveway relocations, etc. NCDOT shall also detail in the PCN whether or not another entity (i.e., other than NCDOT) will apply for those non-transportation facility impacts to waters of the U.S. separately. If NCDOT will apply for both the transportation AND non-transportation facility impacts to waters of the U.S. for a specific project (or some but not all of the non-transportation facilities), NCDOT will provide the required information for both the transportation AND the non-transportation facility impacts in the project summary and the impact table sections of the PCN. In those situations where NCDOT applies for and receives authorization to impact waters of the U.S. for both the transportation facility AND the non-transportation facilities for a specific project (or some but not all of the non-transportation facilities), NCDOT will be the responsible party/permittee for all permit-related matters for those impacts to waters of the U.S. to include the responsibility for permit compliance and obtaining any required compensatory mitigation.

Also authorized under “b”: (1) stream relocation(s) and (2) temporary impacts, such as those from temporary structures, fills, dewatering, and other work necessary to conduct the activities listed under “b”. Stream relocation(s) and temporary impacts will be evaluated independently and are not limited to the permanent loss limits of (1) 1,000 lf of

P-11

stream and/or 3 acres of wetland/open water in the coastal plain OR (2) 1,000 lf of stream and/or 2 acres of wetland/open water in all other areas of North Carolina (i.e., stream relocations and/or temporary impacts do not factor into these limits) for each interchange or intersection project; however, if the Corps determines that the proposed stream relocation(s) and/or temporary impacts are of such magnitude that they cannot be authorized under this section (“b”) of RGP 50, even if the permanent losses from improvement of interchanges or intersections, or construction of interchanges or intersections over, or on, existing roads do not exceed the impact limits for this section (“b”) of RGP 50, an Individual Permit will be required.

If the Corps determines, on a case-by-case basis, that the concerns for the aquatic environment so indicate, he/she may exercise discretionary authority to override this RGP and require an Individual Permit.

1. Special Conditions

a. The prospective permittee must submit a pre-construction notification (PCN) and applicable supporting information to the District Engineer and receive written verification from the Corps that the proposed work complies with this RGP prior to commencing any activity authorized by this RGP.

b. If the project will not impact a designated “Area of Environmental Concern” (AEC) in the twenty* (20) counties of North Carolina covered by the North Carolina Coastal Area Management Act (CAMA) (“CAMA counties”), a consistency submission is not required. If the project will impact a designated AEC and meets the definition of “development”, the prospective permittee must obtain the required CAMA permit. Development activities shall not commence until a copy of the approved CAMA permit is furnished to the appropriate Corps Regulatory Field Office (Wilmington Field Office – 69 Darlington Avenue, Wilmington, NC 28403 or Washington Field Office – 2407 West 5th Street, Washington, NC 27889).

***The 20 CAMA counties in North Carolina include Beaufort, Bertie, Brunswick, Camden, Carteret, Chowan, Craven, Currituck, Dare, Gates, Hertford, Hyde, New Hanover, Onslow, Pamlico, Pasquotank, Pender, Perquimans, Tyrrell, and Washington.**

c. No work shall be authorized by this RGP within the 20* CAMA counties without prior consultation with the National Oceanic and Atmospheric Administration’s (NOAA) Habitat Conservation Division. For each activity reviewed by the Corps where it is determined that the activity may affect Essential Fish Habitat (EFH) for federally managed species, an EFH Assessment shall be prepared by the prospective permittee and forwarded to the Corps and NOAA Fisheries for review and comment prior to authorization of work.

d. Culverts and pipes. The following conditions [(1)-(8)] apply to the construction of culverts/pipes, and work on existing culverts/pipes.

Additionally, if the proposed work would affect an existing culvert/pipe (e.g., culvert/pipe extensions), the prospective permittee must include actions (in the PCN) to correct any existing deficiencies that are located:

- At the inlet and/or outlet of the existing culvert/pipe, IF these deficiencies are/were caused by the existing culvert/pipe, or
- Near the inlet or outlet of the existing culvert/pipe, IF these deficiencies are/were caused by the existing culvert/pipe.

These deficiencies may include, but are not limited to, stream over-widening, bank erosion, streambed scour, perched culvert/pipes, and inadequate water depth in culvert(s). Also note if the proposed work would address the existing deficiency or eliminate it – e.g., bank erosion on left bank, but the culvert extension will be placed in this eroded area. If the prospective permittee is unable to correct the deficiencies caused by the existing culvert/pipe, they must document the reasons in the PCN for Corps consideration.

(1) No activity may result in substantial, permanent disruption of the movement of those species of aquatic life indigenous to the waterbody, including those species that normally migrate through the area. Measures will be included that will promote the safe passage of fish and other aquatic organisms.

(2) The dimension, pattern, and profile of the stream above and below a culvert/pipe shall not be modified by widening the stream channel or by reducing the depth of the stream in connection with the construction activity. It is acceptable to use rock vanes at culvert/pipe outlets to ensure, enhance, or maintain aquatic passage. Pre-formed scour holes are acceptable when designed for velocity reduction. The width, height, and gradient of a proposed opening shall be such as to pass the average historical low flow and spring flow without adversely altering flow velocity. Spring flow will be determined from gauge data, if available. In the absence of such data, bankfull flow will be used as a comparable level.

(3) Burial/depth specifications: If the project is located within any of the 20* CAMA counties, culvert/pipe inverts will be buried at least one foot below normal bed elevation when they are placed within the Public Trust AEC and/or the Estuarine Waters AEC as designated by CAMA. If the project is located outside of the 20* CAMA counties, culvert/pipe inverts will be buried at least one foot below the bed of the stream for culverts/pipes that are greater than 48 inches in diameter. Culverts/pipes that are 48 inches in diameter or less shall be buried or placed on the stream bed as practicable and appropriate to maintain aquatic passage, to include passage during

drought or low flow conditions. Every effort shall be made to maintain the existing channel slope. A waiver from the burial/depth specifications in this condition may be requested in writing. The prospective permittee is encouraged to request agency input about waiver requests as early as possible, and prior to submitting the PCN for a specific project; this will allow the agencies time to conduct a site visit, if necessary, and will prevent time delays and potential project revisions for the prospective permittee. The waiver will only be issued by the Corps if it can be demonstrated that the impacts of complying with burial requirements would result in more adverse impacts to the aquatic environment.

(4) Appropriate actions to prevent destabilization of the channel and head cutting upstream shall be incorporated in the design and placement of culverts/pipes.

(5) Culverts/pipes placed within riparian and/or riverine wetlands must be installed in a manner that does not restrict the flow and circulation patterns of waters of the U.S. Culverts/pipes placed across wetland fills purely for the purposes of equalizing surface water do not have to be buried but must be of adequate size and/or number to ensure unrestricted transmission of water.

(6) Bankfull flows (or less) shall be accommodated through maintenance of the existing bankfull channel cross sectional area in no more than one culvert/pipe or culvert/pipe barrel. Additional culverts/pipes or barrels at such crossings shall be allowed only to receive flows exceeding the bankfull flow. A waiver from this condition may be requested in writing; this request must be specific as to the reason(s) for the request. The waiver will be issued if it can be demonstrated that it is not practicable to comply with this condition.

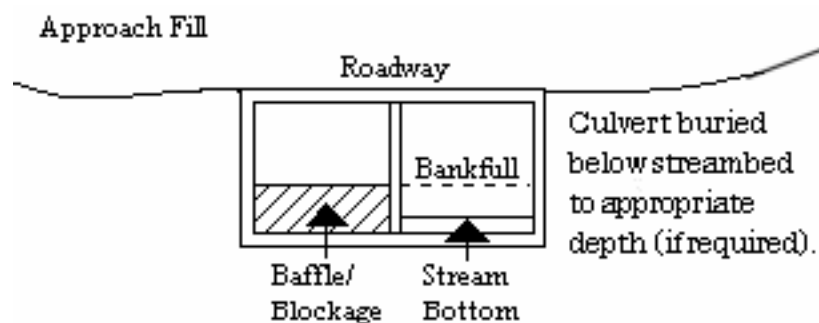

(7) Where adjacent floodplain is available, flows exceeding bankfull will be accommodated by installing culverts/pipes at the floodplain elevation. When multiple culverts/pipes are used, baseflow must be maintained at the appropriate width and depth by the construction of floodplain benches, sills, and/or construction methods to ensure that the overflow culvert(s)/pipe(s) is elevated above the baseflow culvert(s)/pipe(s).

(8) The width of the baseflow culvert/pipe shall be comparable to the width of the bankfull width of the stream channel. If the width of the baseflow culvert/pipe is wider than the stream channel, the culvert/pipe shall include baffles, benches and/or sills to maintain the width of the stream channel. A waiver from this condition may be requested in writing; this request must be specific as to the reason(s) for the request. The waiver will be issued if it can be demonstrated that it is not practicable or necessary to include baffles, benches or sills.

See the remaining special conditions for additional information about culverts/pipes in specific areas.

e. Discharges into waters of the U.S. designated by either the North Carolina Division of Marine Fisheries (NCDMF) or the North Carolina Wildlife Resources Commission (NCWRC) as anadromous fish spawning areas are prohibited during the period between February 15th and June 30th, without prior written approval from the Corps and the appropriate wildlife agencies (NCDMF, NCWRC, and/or the National Marine Fisheries Service (NMFS)). Discharges into waters of the U.S. designated by NCWRC as primary nursery areas in inland waters are prohibited during the period between February 15th and September 30th, without prior written approval from the Corps and the appropriate wildlife agencies. Discharges into waters of the U.S. designated by NCDMF as primary nursery areas shall be coordinated with NCDMF prior to being authorized by this RGP. Coordination with NCDMF may result in a required construction moratorium during periods of significant biological productivity or critical life stages.

The prospective permittee should contact:

**NC Division of Marine Fisheries North Carolina Wildlife Resources
Commission**
3441 Arendell Street Habitat Conservation Division
Morehead City, NC 28557 1721 Mail Service
Center Telephone 252-726-7021 Raleigh, NC
27699-1721 or 800-682-2632 Telephone (919) 707-
0220

f. This permit does not authorize the use of culverts in areas designated as anadromous fish spawning areas by the NCDMF or the NCWRC.

g. No in-water work shall be conducted in Waters of the U.S. designated as Atlantic sturgeon critical habitat during the periods between February 1st and June 30th. No in-water work shall be conducted in Waters of the U.S. in the Roanoke River designated as Atlantic sturgeon critical habitat during the periods between February 1st and June 30th, and between August 1st to October 31st, without prior written approval from NMFS.

h. Before discharging dredged or fill material into waters of the U.S. in designated trout watersheds in North Carolina, the PCN will be sent to the NCWRC and the Corps concurrently. See <https://www.saw.usace.army.mil/Missions/Regulatory-Permit-Program/Agency-Coordination/Trout.aspx> for the designated trout watersheds. The PCN shall summarize alternatives to conducting work in waters of the U.S. in trout watersheds that were considered during the planning process and detail why alternatives were or were not selected. For proposals where (1) a bridge in a trout stream will be replaced with a culvert, or (2) a culvert will be placed in a trout stream, the PCN must also include a compensatory mitigation plan for all loss of stream bed, and details of any on-site evaluations that were conducted to determine that installation of a culvert will not adversely affect passage of fish or other aquatic biota at the project site. The evaluation information must include factors such as the proposed slope of the culvert and determinations of how the slope will be expected to allow or impede passage, the necessity of baffles and/or sills to ensure passage, design considerations to ensure that expected baseflow will be maintained for passage and that post-construction velocities will not prevent passage, site conditions that will or will not allow proper burial of the culvert, existing structures (e.g., perched culverts, waterfalls, etc.) and/or stream patterns up and downstream of the culvert site that could affect passage and bank stability, and any other considerations regarding passage. The level of detail for this information shall be based on site conditions (i.e., culverts on a slope over 3% will most likely require more information than culverts on a slope that is less than 1%, etc.). Also, in order to evaluate potential impacts, the prospective permittee will describe bedforms that will be impacted by the proposed culvert – e.g., pools, glides, riffles, etc. The NCWRC will respond to both the prospective permittee and the Corps.

i. For all activities authorized by this RGP that involve the use of riprap material for bank stabilization, the following measures shall be applied:

(1) Filter cloth must be placed underneath the riprap as an additional requirement of its use in North Carolina waters; however, the prospective permittee may request a waiver from this requirement. The waiver request must be in writing. The Corps will only issue a waiver if the prospective permittee demonstrates that the impacts of complying with this requirement would result in greater adverse impacts to the aquatic environment. Note that filter fabric is not required if the riprap will be pushed or “keyed” into the bank of the waterbody.

(2) Rip rap shall be placed only on the stream banks, or, if it is necessary to be placed in the stream bed, the finished top elevation of the rip rap shall not exceed that of the original stream bed.

(3) The placement of riprap shall be limited to the areas depicted on submitted work plan drawings.

(4) Riprap shall not be placed in a manner that prevents or impedes fish

passage.

(5) Riprap shall be clean and free from loose dirt or any pollutant except in trace quantities that will not have an adverse environmental effect.

(6) Riprap shall be of a size sufficient to prevent its movement from the authorized alignment by natural forces under normal conditions.

(7) Riprap material shall consist of clean rock or masonry material such as, but not limited to, granite, marl, or broken concrete.

j. Discharges of dredged or fill material into waters of the U.S., including wetlands, must be minimized or avoided to the maximum extent practicable.

k. Generally, off-site detours are preferred to avoid and minimize impacts to the human and natural environment; however, if an off-site detour is considered impracticable, then an on-site detour may be considered as a necessary component of the actions authorized by this RGP. Impacts from the detour may be considered temporary and may not require compensatory mitigation if the impacted area is restored to pre-construction elevations and contours after construction is complete. The permittee shall also restore natural hydrology and stream corridors (if applicable), and reestablish native vegetation/riparian corridors. If the construction of a detour (on-site or off-site) includes standard undercutting methods, removal of all material and backfilling with suitable material is required. See special condition "s" for additional information.

l. All activities authorized by this RGP shall, to the maximum extent practicable, be conducted "in the dry", with barriers installed between work areas and aquatic habitat to protect that habitat from sediment, concrete, and other pollutants. Where concrete is utilized, measures will be taken to prevent live or fresh concrete, including bags of uncured concrete, from coming into contact with waters of the U.S. until the concrete has set and cured. All water in the work area that has been in contact with concrete shall only be returned to waters of the U.S. when it no longer poses a threat to aquatic organisms (concrete is set and cured).

m. In cases where new alignment approaches are to be constructed and the existing approach fill in waters of the U.S. is to be abandoned and no longer maintained as a roadway, the abandoned fill shall be removed and the area will be restored to pre-construction elevations and contours. The permittee shall also restore natural hydrology and stream corridors (if applicable), and reestablish native vegetation/riparian corridors, to the extent practicable. This activity may qualify as compensatory mitigation credit for the project and will be assessed on a case-by-case basis in accordance with Special Conditions "q" and "r" in this document. Any proposed on-site wetland restoration area must be void of utility conflicts and/or utility maintenance areas. A restoration plan detailing this activity will be required with the submittal of the PCN.

n. To the maximum extent practicable, the pre-construction course, condition, capacity, and location of open waters must be maintained for each activity, including stream channelization and storm water management activities, except as provided below. The activity must be constructed to withstand expected high flows. The activity must not restrict or impede the passage of normal or high flows, unless the primary purpose of the activity is to impound water or manage high flows. The activity may alter the pre-construction course, condition, capacity, and location of open waters if it benefits the aquatic environment (e.g., stream restoration or relocation activities).

o. The project must be implemented and/or conducted so that all reasonable and practicable measures to ensure that equipment, structures, fill pads, and work associated with the project do not adversely affect upstream and/or downstream reaches. Adverse effects include, but are not limited to, channel instability, scour, flooding, and/or shoreline/streambank erosion. During construction, the permittee shall routinely monitor for these effects, cease all work if/when detected, take initial corrective measures to correct actively eroding areas, and notify the Corps immediately. Permanent corrective measures may require additional authorization from the Corps.

p. All PCNs will describe sedimentation and erosion control structures and measures proposed for placement in waters of the U.S. To the maximum extent practicable, structures and measures will be depicted on maps, surveys or drawings showing location and impacts to jurisdictional wetlands and streams. In addition, appropriate soil and erosion control measures must be established and maintained during construction. All fills, temporary and permanent, must be adequately stabilized at the earliest practicable date to prevent erosion of fill material into adjacent waters or wetlands.

q. Compensatory mitigation will be required for permanent impacts resulting in a loss of waters of the U.S. due to culvert/pipe installation and other similar activities. Mitigation may be required for stream relocation projects (see Special Condition "r" below). When compensatory mitigation is required, the prospective permittee will attach a proposed mitigation plan to the PCN. Compensatory mitigation proposals will be written in accordance with currently approved Wilmington District guidance and Corps mitigation regulations, unless the purchase of mitigation credits from an approved mitigation bank or the North Carolina Division of Mitigation Services (NCDMS) is proposed to address all compensatory mitigation requirements. The Corps Project Manager will make the final determination concerning the appropriate amount and type of mitigation.

r. Stream Relocations (non-tidal only). Stream relocation is when a stream is moved laterally to a new location to allow a project, or part of a project, to be constructed in the stream's former location. For permitting purposes, stream relocations are considered a loss of waters of the U.S. The new/relocated stream itself may reduce the

amount of compensatory mitigation that is required for a specific stream relocation activity. Depending on the condition and location of (1) the existing stream, and (2) the relocated stream, the relocated stream may provide a functional uplift of overall stream function. The Corps will determine if an uplift is possible based on the information submitted with the PCN. If the anticipated uplift(s) occurs, it may offset, either partially or fully, the loss associated with a stream relocation(s) - i.e., due to the uplift, either no compensatory mitigation would be required for the stream relocation itself, or compensatory mitigation would be required at a reduced ratio.

Because the amount of potential uplift is, in part, dependent upon the condition (or quality) of the channel to be relocated, there is no pre-determined amount of uplift needed to satisfy the requirements for a successful relocation project. After performing the evaluation(s) noted in this document, the prospective permittee will propose a certain amount of uplift potential and the Corps project manager will make the final determination. Baseline conditions and subsequent monitoring must show that the relocated channel is providing/will provide aquatic function at, or above, the level provided by the baseline (pre-project) condition. If the required uplift is not achieved, the work will not be in compliance with this special condition of RGP 50 and remediation will be required through repair (and continued monitoring), or by the permittee providing compensatory mitigation (e.g., mitigation credit through an approved bank, mitigation credit through NCDMS, etc.).

Compensatory mitigation, in addition to the stream relocation activity, may be required if the Corps determines that (a) no uplift in stream function is achievable, (b) the proposed uplift in stream function is not sufficient, by itself, (c) the risks associated with achieving potential uplifts in stream function are excessive, and/or (d) the time period for achieving the potential uplifts/functional success is too great.

On-site compensatory mitigation is not the same as stream relocation. While stream relocation simply moves a stream to a nearby, geographically similar area, it does not generate mitigation credits. If NCDOT proposes to generate compensatory mitigation on a project site, NCDOT must submit a mitigation plan that complies with 33 CFR 332.4.

The prospective permittee is required to submit the following information for any proposed project that involves stream relocation, regardless of the size/length of the stream relocation (note that 1-5 below only apply to stream relocations and not to compensatory mitigation):

- (1) A statement detailing why relocating the stream is unavoidable. In order to ensure that this action is separate from a compensatory mitigation project, the need for the fill must be related to road/interchange/intersection construction or improvement, and the project must meet the requirements set forth in the full descriptions/terms of "a" and "b" on pages 2 and 3 of this permit.

- (2) An evaluation of effects on the relocated stream and buffer from utilities, or potential for impact from utility placement in the future.
- (3) An evaluation of the baseline condition of the stream to be relocated. In order to demonstrate a potential uplift, the prospective permittee must provide the baseline (pre-impact) condition of the stream that is proposed for relocation. The prospective permittee will document the baseline condition of the stream by using the Corps' (Wilmington District's) current functional assessment method - e.g., the North Carolina Stream Assessment Method (NCSAM). The functional assessment must be used to identify specific areas where an uplift would reasonably be expected to occur, and also show important baseline functions that will remain after the relocation.
- (4) An evaluation of the potential uplifts to stream function for the relocated channel. The amount of detail required in the plan will be commensurate with the functional capacity of the original stream and proposed uplift(s). Low functional capacity will warrant less monitoring and less detail in the plan in order to ensure that the relocated channel provides the same, or better/increased, suite of aquatic functions as the existing channel.

Note that to either reduce or eliminate the need to provide compensatory mitigation for stream relocation impacts, the bed of the relocated stream should not be hardened or stabilized, to include embedded rip rap; note that grade control structures are acceptable. Additionally, the relocated channel should have similar or better pattern, profile, and dimension than the existing channel. Finally, the banks of the relocated channel should not be hardened, although limited stabilization may be acceptable if NCDOT adequately demonstrates why this is necessary.

- (5) A proposed monitoring plan for the relocated channel (and buffer, if applicable), will be prepared in accordance with current District guidance. The level of detail needed in the plan will be directly related to the quality of baseline functions and the anticipated uplift, therefore it is recommended that a pre-application discussion occur with the Corps Project Manager as early as possible. For example, if the risk for achieving the anticipated functional uplift is moderate or low, or if there is a low amount of proposed uplift, less information and monitoring will be required in the proposed relocation plan; similar to the requirements found in the "2003 Stream Mitigation Guidelines". If the risk for uplift is higher, or if there is a high amount of proposed uplift, additional monitoring and information will be required, trending toward the prescriptions found in the most recent Wilmington District Compensatory Mitigation Guidance – e.g., the 2016 Wilmington District Stream and Wetland Compensatory Mitigation Update. All monitoring will be for at least 5 years unless the Corps project manager determines that (a) a specific project requires less than 5 years

due to site conditions or limited risk/uplift potential, and/or complexity (or simplicity) of the existing channel and/or the relocation work, or (b) the Corps project manager determines (during the monitoring period) that the 5 years of monitoring may be reduced (or that no further monitoring is required) based on monitoring information received once the stream relocation has been completed.

s. Upon completion of any work authorized by this RGP, all temporary fills (to include culverts, pipes, causeways, etc.) will be completely removed from waters of the U.S. and the areas will be restored to pre-construction elevations and contours. The permittee shall also restore natural hydrology and stream corridors (if applicable) and reestablish native vegetation/riparian corridors. This work will be completed within 60 days of completion of project construction. If this timeframe occurs while a required moratorium of this permit is in effect, the temporary fill shall be removed in its entirety within 60 days of the moratorium end date. If vegetation cannot be planted due to the time of the year, all disturbed areas will be seeded with a native mix appropriate for the impacted area, and vegetation will be planted during the next appropriate time frame. A native seed mix may contain non-invasive small grain annuals (e.g. millet and rye grain) to ensure adequate cover while native vegetation becomes established. The PCN must include a restoration plan showing how all temporary fills and structures will be removed and how the area will be restored to pre-project elevations and contours.

t. Borrow and Waste Activities. For those projects that involve borrow and/or waste activities (note that if the borrow or waste area is also used for purposes/clients other than NCDOT, this condition will not apply to an NCDOT project) - To ensure that all borrow and waste activities occur on high ground and do not result in the degradation of adjacent waters and wetlands, except as authorized by the RGP verification letter issued for a specific project, the permittee shall require its contractors and/or agents to identify all areas to be used as borrow and/or waste sites associated with an authorized project. The permittee shall provide the Corps with appropriate maps indicating the locations of proposed borrow and/or waste sites as soon as such information is available. The permittee shall submit to the Corps site-specific information needed to ensure that borrow and/or waste sites comply with all applicable Federal requirements, to include compliance with the Endangered Species Act and the National Historic Preservation Act, such as surveys or correspondence with agencies (e.g., the USFWS, the NC HPO, etc.). The required information shall also include the location of all aquatic features, if any, out to a distance of 400 feet beyond the nearest boundary of the site. The permittee shall not approve any borrow and/or waste sites before receiving written confirmation from the Corps that the proposed site meets all Federal requirements, whether or not waters of the U.S., including wetlands, are located in the proposed borrow and/or waste site. All delineations of aquatic sites on borrow and/or waste sites shall be verified by the Corps and shown on the approved reclamation plans. The permittee shall ensure that all borrow and/or waste sites comply with the following: Except as authorized by this permit or any

Corps approved modification to this permit, no excavation, fill, or mechanized land-clearing activities shall take place at any time in the construction or maintenance of this project, within waters or wetlands, or shall any activities take place that cause the degradation of waters or wetlands. There shall be no excavation from, waste disposal into, or degradation of, jurisdictional wetlands or waters associated with this permit without appropriate modification of this permit, including appropriate compensatory mitigation. This prohibition applies to all borrow and waste activities connected with this project. Additionally, the permittee shall produce and maintain documentation of all borrow and waste sites associated with this project. This documentation will include data regarding soils, vegetation, hydrology, any delineation(s) of aquatic sites, and any jurisdictional determinations made by the Corps. All information will be available to the Corps upon request. The permittee shall require its contractors to complete and execute reclamation plans for each borrow and/or waste site and provide written documentation that the reclamation plans have been implemented and all work is completed. This documentation will be provided to the Corps within 30 days of the completion of the reclamation work.

u. Once the authorized work in waters of the U.S. is complete, the permittee shall sign and return the compliance certificate that is attached to the RGP verification letter.

v. The District Engineer will consider any comments from Federal and/or State agencies concerning the proposed activity's compliance with the terms and conditions of this RGP.

w. The Corps may place additional special conditions, limitations, or restrictions on any verification of the use of RGP 50 on a project-by-project basis.

2. General Conditions

a. The permittee shall ensure that the construction design plans do not deviate from the permit plans referenced in the RGP verification letter issued for a specific project. Any modification to the permit plans referenced in the RGP verification letter for a specific project must be approved by the Corps prior to any active construction in waters or wetlands.

b. Except as authorized by an RGP verification letter issued for a specific project and the supporting plans referenced in that verification letter, or any Corps approved modification to an RGP verification letter for a specific project, no excavation, fill or mechanized land-clearing activities shall take place within waters or wetlands, at any time during construction or maintenance of the project. This permit does not authorize temporary placement or double handling of excavated or fill material within waters or wetlands outside the permitted area. This prohibition applies to all borrow and fill activities connected with the project.

c. The permittee shall require its contractors and/or agents to comply with (1) the terms and conditions of this permit and (2) all conditions in the RGP verification letter for that project. The permittee shall provide each of its contractors and/or agents associated with the construction or maintenance of a specific project with a copy of this permit and the RGP verification letter. A copy of this permit and the RGP verification letter, including all conditions, drawings/plans and attachments shall be available at the project site during the construction and maintenance of any project authorized by an RGP verification letter.

d. During the clearing phase of the project, heavy equipment shall not be operated in surface waters or stream channels. Temporary stream crossings will be used to access the opposite sides of stream channels. All temporary diversion channels and stream crossings will be constructed of non-erodible materials. Grubbing of riparian vegetation will not occur until immediately before construction begins on a given segment of stream channel.

e. All mechanized equipment shall be regularly inspected and maintained to prevent contamination of waters and wetlands from fuels, lubricants, hydraulic fluids, or other toxic materials. In the event of a spill of petroleum products or any other hazardous waste, the permittee shall immediately report it to the N.C. Division of Water Resources at (919) 733-3300 or (800) 858-0368 and provisions of the North Carolina Oil Pollution and Hazardous Substances Control Act shall be followed.

f. Authorization under this RGP does not obviate the need to obtain other federal, state, or local authorizations.

g. All work authorized by this RGP must comply with the terms and conditions of the applicable CWA Section 401 Water Quality Certification for this RGP issued by the North Carolina Division of Water Resources (NCDWR).

h. The permittee shall employ all sedimentation and erosion control measures necessary to prevent an increase in sedimentation or turbidity within waters and wetlands outside of the permit area. This shall include, but is not limited to, the immediate installation of silt fencing or similar appropriate devices around all areas subject to soil disturbance or the movement of earthen fill, and the immediate stabilization of all disturbed areas. Additionally, the project must remain in full compliance with all aspects of the Sedimentation Pollution Control Act of 1973 (North Carolina General Statutes Chapter 113A Article 4).

i. The permittee shall remove all sediment and erosion control measures placed in waters and/or wetlands, and shall restore natural grades on those areas, prior to project completion.

j. The activities authorized by this RGP must not interfere with the public's right to free navigation on all navigable waters of the U.S. No attempt will be made by the

permittee to prevent the full and free use by the public of all navigable waters at, or adjacent to, the authorized work for a reason other than safety.

k. The permittee understands and agrees that if future operations by the U.S. require the removal, relocation, or other alteration, of the structure or work herein authorized, or if, in the opinion of the Secretary of the Army or his authorized representative, said structure or work shall cause unreasonable obstruction to the free navigation of the navigable waters, the permittee will be required, upon due notice from the Corps, to remove, relocate, or alter the structural work or obstructions caused thereby, without expense to the U.S. No claim shall be made against the U.S. on account of any such removal or alteration.

l. The permittee, upon receipt of a notice of revocation of this RGP for the verified individual activity, may apply for an individual permit, or will, without expense to the U.S. and in such time and manner as the Secretary of the Army or his/her authorized representative may direct, restore the affected water of the U.S. to its former conditions.

m. This RGP does not authorize any activity that would conflict with a federal project's congressionally authorized purposes, established limitations or restrictions, or limit an agency's ability to conduct necessary operation and maintenance functions. Per Section 14 of the Rivers and Harbors Act of 1899, as amended (33 U.S.C. 408), no project that has the potential to take possession of or make use of for any purpose, or build upon, alter, deface, destroy, move, injure, or obstruct a federally constructed work or project, including, but not limited to, levees, dams, jetties, navigation channels, borrow areas, dredged material disposal sites, flood control projects, etc., shall be permitted unless the project has been reviewed and approved by the appropriate Corps approval authority. Permittees shall not begin the activity authorized by this RGP until notified by the Corps that the activity may proceed.

n. The permittee shall obtain a Consent to Cross Government Easement from the appropriate Corps District's Land Use Coordinator prior to any crossing of a Corps easement and/or prior to commencing construction of any structures, authorized dredging, or other work within the right-of-way of, or in proximity to, a federally designated disposal area.

o. Federal Navigation Channel Setbacks. Authorized structures and fills located in or adjacent to Federally authorized waterways must be constructed in accordance with the latest setback criteria established by the Wilmington District Engineer. You may review the setback policy at <http://www.saw.usace.army.mil/Missions/Navigation/Setbacks.aspx>. This RGP permit does not authorize the construction of hardened or permanently fixed structures within the Federally Authorized Channel Setback, unless the activity is approved by the Corps.

p. The permittee will allow the Wilmington District Engineer or his/her representative to inspect the authorized activity at any time deemed necessary to ensure that the activity is being performed or maintained in strict accordance with the Special and General Conditions of this permit.

q. This RGP does not grant any property rights or exclusive privileges.

r. This RGP does not authorize any injury to the property or rights of others.

s. This RGP does not authorize the interference with any existing or proposed federal project.

t. In issuing this permit, the Federal Government does not assume any liability for the following:

(1) Damages to the permitted project or uses thereof as a result of other permitted or unpermitted activities or from natural causes.

(2) Damages to the permitted project or uses thereof as a result of current or future activities undertaken by or on behalf of the U.S. in the public interest.

(3) Damages to persons, property, or to other permitted or unpermitted activities or structures caused by the activity authorized by this permit.

(4) Design or construction deficiencies associated with the permitted work.

(5) Damage claims associated with any future modification, suspension, or revocation of this permit.

u. Authorization provided by this RGP may be modified, suspended or revoked in whole, or in part, if the Wilmington District Engineer, acting for the Secretary of the Army, determines that such action would be in the best public interest. The term of this RGP shall be five (5) years unless subject to modification, suspension, or revocation. Any modification, suspension, or revocation of this authorization will not be the basis for any claim for damages against the U.S. Government.

v. No activity may occur in a component of the National Wild and Scenic Rivers System, or in a river officially designated by Congress as a "study river" for possible inclusion in the system while the river is in an official study status, unless the appropriate Federal agency with direct management responsibility for such river, has determined in writing that the proposed activity will not adversely affect the Wild and Scenic designation

or study status. Information on Wild and Scenic Rivers may be obtained from the appropriate Federal land management agency responsible for the designated Wild and Scenic River or “study river” (e.g., National Park Service, U.S. Forest Service, etc.).

w. Endangered Species

(1) No activity is authorized under this RGP which is likely to directly or indirectly jeopardize the continued existence of a threatened or endangered species or a species proposed for such designation, as identified under the Federal Endangered Species Act (ESA), or which will directly or indirectly destroy or adversely modify the critical habitat of such species. No activity is authorized under this RGP which “may affect” a listed species or critical habitat, unless Section 7 consultation addressing the effects of the proposed activity has been completed.

(2) Federal agencies should follow their own procedures for complying with the requirements of the ESA. Federal prospective permittees (and when FHWA is the lead federal agency) must provide the District Engineer with the appropriate documentation to demonstrate compliance with those requirements. The District Engineer will review the documentation and determine whether it is sufficient to address ESA compliance for the RGP activity, or whether additional ESA consultation is necessary.

(3) Non-federal prospective permittees - for activities that might affect federally listed endangered or threatened species or designated critical habitat, the PCN must include the name(s) of the endangered or threatened species that might be affected by the proposed work or that utilize the designated critical habitat that might be affected by the proposed work. The District Engineer will determine whether the proposed activity “may affect” or will have “no effect” to listed species and designated critical habitat. In cases where the non-federal prospective permittee has identified listed species or critical habitat that might be affected or is in the vicinity of the project, and has so notified the Corps, the prospective permittee shall not begin work until the Corps has provided notification that the proposed activities will have “no effect” on listed species or critical habitat, or until Section 7 consultation has been completed.

(4) As a result of formal or informal consultation with the U.S. Fish and Wildlife Service (USFWS) or NMFS, the District Engineer may add species-specific endangered species conditions to the RGP verification letter for a project.

(5) Authorization of an activity by a RGP does not authorize the “take” of a threatened or endangered species as defined under the ESA. In the absence of separate authorization (e.g., an ESA Section 10 Permit, a Biological Opinion with “incidental take” provisions, etc.) from the USFWS or the NMFS, the ESA prohibits any person subject to the jurisdiction of the U.S. to take a listed species, where “take” means to harass, harm, pursue, hunt, shoot, wound, kill, trap, capture, or collect, or to attempt to engage in any

such conduct. The word “harm” in the definition of “take” means an act which actually kills or injures wildlife. Such an act may include significant habitat modification or degradation where it actually kills or injures wildlife by significantly impairing essential behavioral patterns, including breeding, feeding or sheltering.

(6) Information on the location of threatened and endangered species and their critical habitat can be obtained directly from the offices of the USFWS in North Carolina at the addresses provided below, or from the USFWS and NMFS via their world wide web pages at <http://www.fws.gov/> or <http://www.fws.gov/ipac> and <http://www.noaa.gov/fisheries.html> respectively.

USFWS offices in North Carolina:

The Asheville USFWS Office covers all NC counties west of, and including, Anson, Stanly, Davidson, Forsyth and Stokes Counties.

US Fish and Wildlife Service
Asheville Field Office
160 Zillicoa Street
Asheville, NC 28801
Telephone: (828) 258-3939

The Raleigh USFWS Office covers all NC counties east of, and including, Richmond, Montgomery, Randolph, Guilford, and Rockingham Counties.

US Fish and Wildlife Service
Raleigh Field Office
Post Office Box 33726
Raleigh, NC 27636-3726
Telephone: (919) 856-4520

x. The Wilmington District, USFWS, NCDOT, and the FHWA have conducted programmatic Section 7(a)(2) consultation for a number of federally listed species and habitat, and programmatic consultation concerning other federally listed species and/or habitat may occur in the future. The result of completed programmatic consultation is a Programmatic Biological Opinion (PBO) issued by the USFWS. These PBOs contain mandatory terms and conditions to implement the reasonable and prudent measures that are associated with “incidental take” of whichever species or critical habitat is covered by a specific PBO. Authorization under RGP 50 is conditional upon the permittee’s compliance with all the mandatory terms and conditions associated with incidental take of the applicable PBO (or PBOs), which are incorporated by reference in RGP 50. Failure to comply with the terms and conditions associated with incidental take of an applicable PBO, where a take of the federally listed species occurs, would constitute an unauthorized take by the permittee, and would also constitute permittee non-compliance with the authorization under RGP 50. If the terms and conditions of a specific PBO (or PBOs)

apply to a project, the Corps will include this/these requirements in any RGP 50 verification that may be issued for a project. The USFWS is the appropriate authority to determine compliance with the terms and conditions of its PBO, and with the ESA.

y. For proposed activities the sixteen (16) counties listed below, prospective permittees must provide a copy of the PCN to the USFWS, 160 Zillicoa Street, Asheville, North Carolina 28801. This PCN must be sent concurrently to the USFWS and the Corps Project Manager for that specific county.

The 16 counties with tributaries that drain to designated critical habitat that require notification to the Asheville USFWS are: Avery, Cherokee, Forsyth, Graham, Haywood, Henderson, Jackson, Macon Mecklenburg, Mitchell, Stokes, Surry, Swain, Transylvania, Union and Yancey.

z. If the permittee discovers or observes any live, damaged, injured or dead individual of an endangered or threatened species during construction, the permittee shall immediately notify the Wilmington District Engineer so that required coordination can be initiated with the U.S. Fish and Wildlife Service and/or National Marine Fisheries Service.

aa. Historic Properties.

(1) In cases where the District Engineer determines that the activity may have the potential to cause effects to properties listed, or eligible for listing, in the National Register of Historic Places (NRHP), the activity is not authorized, until the requirements of Section 106 of the National Historic Preservation Act (NHPA) have been satisfied.

(2) Federal prospective permittees (or when FHWA is the lead federal agency) should follow their own procedures for complying with the requirements of Section 106 of the NHPA. Federal prospective permittees must provide the District Engineer with the appropriate documentation to demonstrate compliance with those requirements; this includes copies of correspondence sent to all interested, federally recognized tribes and a summary statement about tribal consultation efforts or, if the Corps enters into a Programmatic Agreement (PA) with the FHWA/NCDOT, documentation that the FHWA/NCDOT has complied with PA requirements. The District Engineer will review the documentation and determine whether it is sufficient to address Section 106 compliance for this RGP activity, or whether additional Section 106 consultation is necessary.

(3) Non-federal prospective permittees - the PCN must state which historic properties may be affected by the proposed work or include a vicinity map indicating the location of the historic properties or the potential for the presence of historic properties. Assistance regarding information on the location of or potential for the presence of historic resources can be sought from the State Historic Preservation

Officer (SHPO) and/or Tribal Historic Preservation Officer (THPO), as appropriate, and the NRHP (see 33 CFR 330.4(g)). When reviewing PCNs, the District Engineer will comply with the current procedures for addressing the requirements of Section 106 of the NHPA. The District Engineer shall make a reasonable and good faith effort to carry out appropriate identification efforts, which may include background research, consultation, oral history interviews, sample field investigation, and field survey. Based on the information submitted and these efforts, the District Engineer shall determine whether the proposed activity has the potential to cause an effect on the historic properties.

(4) Section 106 consultation is not required when the Corps determines that the activity does not have the potential to cause effects on historic properties (see 36 CFR §800.3(a)).

(5) Section 110k of the NHPA (16 U.S.C. 470h-2(k)) prevents the Corps from granting a permit or other assistance to a prospective permittee who, with intent to avoid the requirements of Section 106 of the NHPA, has intentionally significantly adversely affected a historic property to which the permit will relate, or having legal power to prevent it, allowed such significant adverse effect to occur, unless the Corps, after consultation with the Advisory Council on Historic Preservation (ACHP), determines that circumstances justify granting such assistance despite the adverse effect created or permitted by the prospective permittee. If circumstances justify granting the assistance, the Corps is required to notify the ACHP and provide documentation specifying the circumstances, the degree of damage to the integrity of any historic properties affected, and proposed mitigation. This documentation must include any views obtained from the prospective permittee, SHPO/THPO, appropriate Indian tribes if the undertaking occurs on or affects historic properties on tribal lands or affects properties of interest to those tribes, and other parties known to have a legitimate interest in the impacts to the permitted activity on historic properties.

bb. If you discover any previously unknown historic, cultural, or archeological remains and/or artifacts while accomplishing the activity authorized by this general permit, you must immediately notify the District Engineer of what you have found, and to the maximum extent practicable, avoid construction activities that may affect the remains and/or artifacts until the required coordination has been completed. The District Engineer will initiate the Federal, Tribal, and state coordination required to determine if the remains warrant a recovery effort or if the site is eligible for listing in the National Register of Historic Places.

cc. Permittees are advised that development activities in or near a floodway may be subject to the National Flood Insurance Program that prohibits any development, including fill, within a floodway that results in any increase in base flood elevations. This general permit does not authorize any activity prohibited by the National Flood Insurance Program.

dd. The permittee must install and maintain, at his/her expense, any signal lights and signals prescribed by the U.S. Coast Guard, through regulations or otherwise, on authorized facilities. For further information, the permittee should contact Coast Guard Sector North Carolina at (910) 772-2191 or email Coast Guard Fifth District at cgd5waterways@uscg.mil.

ee. The permittee must maintain any structure or work authorized by this general permit in good condition and in conformance with the terms and conditions of this general permit. The permittee is not relieved of this requirement if the permittee abandons the structure or work. Transfer in fee simple of the work authorized by this general permit will automatically transfer this general permit to the property's new owner, with all of the rights and responsibilities enumerated herein. The permittee must inform any subsequent owner of all activities undertaken under the authority of this general permit and provide the subsequent owner with a copy of the terms and conditions of this general permit.

ff. At his or her sole discretion, any time during the processing cycle, the Wilmington District Engineer may determine that this general permit will not be applicable to a specific proposal. In such case, the procedures for processing an individual permit in accordance with 33 CFR 325 will be available.

gg. Except as authorized by this general permit or any Corps approved modification to this general permit, all fill material placed in waters or wetlands shall be generated from an upland source and will be clean and free of any pollutants except in trace quantities. Metal products, organic materials (including debris from land clearing activities), or unsightly debris will not be used.

hh. Except as authorized by this general permit or any Corps approved modification to this general permit, all excavated material will be disposed of in approved upland disposal areas.

ii. Activities which have commenced (i.e., are under construction) or are under contract to commence in reliance upon this general permit will remain authorized provided the activity is completed within twelve months of the date of the general permit's expiration, modification, or revocation. Activities completed under the authorization of this general permit that were in effect at the time the activity was completed continue to be authorized by the general permit.

jj. The permittee is responsible for obtaining any "take" permits required under the USFWS's regulations governing compliance with the Migratory Bird Treaty Act or the Bald and Golden Eagle Protection Act. The permittee should contact the appropriate local office of the USFWS to determine if such "take" permits are required for a particular activity.

kk. The activity must comply with applicable FEMA approved state or local floodplain management requirements.

ll. There will be no unreasonable interference with navigation or the right of the public to riparian access by the existence or use of activities authorized by this RGP.

mm. Unless authorization to fill those specific wetlands or mudflats has been issued by the Corps, heavy equipment working in wetlands or mudflats must be placed on mats, or other measures must be taken to minimize soil disturbance.

nn. This RGP will not be applicable to proposed construction when the Wilmington District Engineer determines that the proposed activity will significantly affect the quality of the human environment and determines that an EIS must be prepared.

oo. Violation of these permit conditions or violation of Section 404 of the Clean Water Act or Section 10 of the Rivers and Harbors Act shall be reported to the Corps in writing and by telephone within 24 hours of the permittee's discovery of the violation. Corps contact information for a specific project can be found at the bottom of the RGP verification letter for that project.

BY AUTHORITY OF THE SECRETARY OF THE ARMY:

FOR THE DISTRICT COMMANDER:



KENNETH M. PORTER
LTC, EN
Acting Commander

JOSH STEIN
Governor

D. REID WILSON
Secretary

RICHARD E. ROGERS, JR.
Director



NORTH CAROLINA
Environmental Quality

March 4, 2026

Ms. Catherine Hossack
Meyer NCDOT Division 2
1037 W.H. Smith Blvd.
Greenville, NC 27835
cahossackmeyer@ncdot.gov

Subject: Re-Issuance- 401 Water Quality Certification Pursuant to Section 401 of the Federal Clean Water Act with ADDITIONAL CONDITIONS for Proposed Replacement of Bridge No. 66 over the Pungo River (BR-0004) at Beaufort County. NCDWR Project No 20250132 v2

Dear Mrs. Hossack:

Attached hereto is a copy of **Water Quality Certification No. WQC008705 (Individual Certification)** issued to the North Carolina Department of Transportation (NCDOT), dated March 4, 2026. This Certification is issued pursuant to the re-issuance request submitted on January 30, 2026, and replaces the Certification previously issued on March 21, 2025.

This approval is for the purpose and design described in your application. The plans and specifications for this project are incorporated by reference as part of this Water Quality Certification. If you change your project, you must notify the Division, and you may be required to submit a new application package with the appropriate fee. If the property is sold, the new owner must be given a copy of this Certification and is responsible for complying with all conditions. [15A NCAC 02H .0507(d)(2)]. This Certification does not relieve the permittee of the responsibility to obtain all other required Federal, State, or Local approvals before proceeding with the project, including those required by, but not limited to, Sediment and Erosion Control, Non-Discharge, Water Supply Watershed, and Trout Buffer regulations.

If we can be of further assistance, do not hesitate to contact us.



North Carolina Department of Environmental Quality | Division of Water Resources
512 North Salisbury Street | 1617 Mail Service Center | Raleigh, North Carolina 27699-1617
919.707.9000

Sincerely,

Signed by:

Faith Hardin

3185423002EA45E...

Faith Hardin, Supervisor

401 & Buffer Transportation Permitting Branch

Electronic cc: Travis Wilson, NC Wildlife Resources Commission
Kyle Barnes, US Army Corps of Engineers, Washington Field Office
Chris Rivenbark, RK&K, crivenbark@rkk.com
Stephen Lane, NC Division of Coastal Management
Jason Elliott, NCDOT, Natural Environment Section
Paul Nyarko, NC Division of Water Resources Regional Office



North Carolina Department of Environmental Quality | Division of Water Resources
512 North Salisbury Street | 1617 Mail Service Center | Raleigh, North Carolina 27699-1617
919.707.9000

Re-Issuance for 401 Water Quality Certification Pursuant to Section 401 of the Federal Clean Water Act with ADDITIONAL CONDITIONS.

THIS CERTIFICATION is issued in conformity with the requirements of Section 401 Public Laws 92-500 and 95-217 of the United States and subject to the North Carolina Division of Water Resources (NCDWR) Regulations in 15 NCAC 2H .0500. This certification authorizes the NCDOT to impact 0.104 acres of open water in Carteret County. The project shall be constructed pursuant to the application dated received January 26, 2026. The authorized impacts are as described below:

Wetlands Impact in the Tar-Pamlico Basin

Bridge 66	Wetlands Fill (ac)	Wetlands Excavation (ac)	Wetlands Temporary Excavation (ac)	Wetlands Hand Clearing (ac)	Total (ac)
404 wetlands	0.35	--	--	0.11	0.46
CAMA wetlands	0.41	0.16	0.10	0.32	0.99
Total	0.76	0.16	0.10*	0.43	1.45

* = temporary impacts associated with on-site mitigation

Total Wetland Impact for Project 1.45 acres.

Open Water Impacts on Tar-Pamlico River Basin (Pungo River)

Site	Open Water Permanent (ac)	Open Water Temporary (ac)
Bridge 66	0.05	1.28
Total	1.33	

Total open water Impact for Project: 1.28 acres.

The application provides adequate assurance that the discharge of fill material into the waters of the **Pungo River** in conjunction with the proposed development will not result in a violation of applicable Water Quality Standards and discharge guidelines. Therefore, the State of North Carolina certifies that this activity will not violate the applicable portions of Sections 301, 302, 303, 306, 307 of PL 92-500 and PL 95-217 if conducted in accordance with the application and conditions hereinafter set forth.

This approval is only valid for the purpose and design that you submitted in your application dated January 30, 2026. Should your project change, you are required to notify the NCDWR and submit a new application. If the property is sold, the new owner must be given a copy of this Certification and approval letter and is thereby responsible for complying with all the conditions. If any additional wetland impacts, or stream impacts, for this project (now or in the future) exceed 0.1 acre or 300 linear feet, respectively, additional compensatory mitigation may be required as described in 15A NCAC 2H .0506 (h) (6) and (7).

For this approval to remain valid, you are required to comply with all the conditions listed below. In addition, you should obtain all other federal, state or local permits before proceeding with your project including (but not limited to) Sediment and Erosion control, Coastal Stormwater, Non-discharge and



Water Supply watershed regulations. This Certification shall expire on the same day as the expiration date of the corresponding Corps of Engineers Permit.

This Water Quality Certification neither grants nor affirms any property right, license, or privilege in any lands or waters, or any right of use in any waters. This Water Quality Certification does not authorize any person to interfere with the riparian rights, littoral rights, or water use rights of any other person and does not create any prescriptive right or any right of priority regarding any usage of water. This Water Quality Certification shall not be interposed as a defense in any action respecting the determination of riparian or littoral rights or other rights to water use. No consumptive user is deemed by virtue of this Water Quality Certification to possess any prescriptive or other right of priority with respect to any other consumptive user regardless of the quantity of the withdrawal or the date on which the withdrawal was initiated or expanded. Upon the presentation of proper credentials, the Division may inspect the property.

Condition(s) of Certification:

1. NCDOT will conduct a pre-construction meeting with all appropriate staff to ensure that the project supervisor and essential staff understand the permit conditions and any potential issues at the permitted site. NCDWR staff shall be invited to the pre-construction meeting. [15A NCAC 02H .0506(b); 15A NCAC 02H .0507(c)]
2. The issuance of this certification does not exempt the Permittee from complying with all statutes, rules, regulations, or ordinances that may be imposed by other government agencies (i.e. local, state, and federal) having jurisdiction, including but not limited to applicable buffer rules, stormwater management rules, soil erosion and sedimentation control requirements, etc.
3. DWR approves the stormwater drainage design as shown in the 401 applications, under the assumption that it meets the requirements of the NCDOT NPDES permit #NCS000250. These plans are enforceable by DWR. Changes to the approved plans are prohibited without prior approval from DWR. If sediment or other pollutants are found to be discharged from the stormwater outfalls, DWR may take enforcement action. NCDOT and DWR shall assess the damage to water quality standards and implement an appropriate action plan to address the impact. The action plan shall provide an appropriate timeline for implementation as agreed upon by both DWR and NCDOT. This may require NCDOT to obtain a modification to its current 401 and 404 permits.
4. Compensatory mitigation for impacts to **0.92 acres** of wetlands (0.35 ac 404, 0.57 ac coastal) is required. The permittee shall comply with the on-site wetland mitigation plan submitted on January 31, 2025. All on-site mitigation sites shall be protected in perpetuity by a conservation easement or through NCDOT fee simple acquisition and recorded in the NCDOT Environmental Analysis Unit mitigation geodatabase. The site shall be monitored for a period of five (5) years. Success of the mitigation site shall be determined by the NCDWR during an on-site visit at or near the end of the monitoring period. [15A NCAC 02H .0506(c)]
5. Any biological surveys required by other state or federal agencies shall be completed prior to ground disturbing activities. [15A NCAC 02H .0506(b); 15A NCAC 02H .0507(c)]



6. The Permittee shall ensure that the final design drawings adhere to the permit and to the permit drawings submitted for approval. [15A NCAC 02H .0507(c) and 15A NCAC 02H .0506 (b)].
7. The outside buffer, wetland or water boundary located within the construction corridor approved by this authorization shall be clearly marked by highly visible fencing prior to any land disturbing activities. Impacts to areas within the fencing are prohibited unless otherwise authorized by this certification. [15A NCAC 02H .0506(b); 15A NCAC 02H .0507(c)]
8. During the construction of the project, no staging of equipment of any kind is permitted in waters of the U.S. or protected riparian buffers. [15A NCAC 02H .0506(b); 15A NCAC 02H.0507(c)]
9. Unless otherwise approved in this certification, placement of culverts and other structures in open waters and streams, shall be placed below the elevation of the streambed by one foot for all culverts with a diameter greater than 48 inches, and 20 percent of the culvert diameter for culverts having a diameter less than 48 inches, to allow low flow passage of water and aquatic life. Design and placement of culverts and other structures including temporary erosion control measures shall not be conducted in a manner that may result in dis-equilibrium of wetlands or streambeds or banks, adjacent to or upstream and downstream of the above structures. The applicant is required to provide evidence that the equilibrium is being maintained if requested in writing by the NCDWR. If this condition is unable to be met due to bedrock or other limiting features encountered during construction, please contact the NCDWR for guidance on how to proceed and to determine whether a permit modification will be required. [15A NCAC 02H.0506(b)(2) and 15A NCAC 02H .0507(c)]
10. If multiple pipes or barrels are required, they shall be designed to mimic natural stream cross section as closely as possible including pipes or barrels at flood plain elevation and/or sills where appropriate. Widening the stream channel should be avoided. Stream channel widening at the inlet or outlet end of structures typically decreases water velocity causing sediment deposition that requires increased maintenance and disrupts aquatic life passage. [15A NCAC 02H.0506(b)(2) and 15A NCAC 02H .0507(c)]
11. All mechanized equipment operated near surface waters must be regularly inspected and maintained to prevent contamination of stream waters from fuels, lubricants, hydraulic fluids, or other toxic materials. [15A NCAC 02H.0506(b){3}]
12. No rock, sand or other materials shall be dredged from the stream channel



- except where authorized by this certification. [15A ISA NCAC 02H.0506(b)(3)]
13. All fill slopes located in jurisdictional wetlands shall be placed at slopes no flatter than 3:1, unless otherwise authorized by this certification. [15A NCAC 02H.0506(b)(1)]
 14. All work in or adjacent to stream waters shall be conducted in a dry work area. Approved BMP measures from the most current version of NCDOT Construction and Maintenance Activities manual such as sandbags, rock berms, cofferdams and other diversion structures shall be used to prevent excavation in flowing water. [15A NCAC 02H.0506(b)(3)]
 15. When applicable, all construction activities shall be performed and maintained in full compliance with G.S. Chapter 113A Article 4 (Sediment and Pollution Control Act of 1973). Regardless of applicability of the Sediment and Pollution Control Act, all projects shall incorporate appropriate Best Management Practices for the control of sediment and erosion so that no violations of state water quality standards, statutes, or rules occur. [15A NCAC 02H.0506(b)(3) and 15A NCAC 02H .0507(c)]
 16. Design, installation, operation, and maintenance of all sediment and erosion control measures shall be equal to or exceed the requirements specified in the most recent version of the *North Carolina Sediment and Erosion Control Manual*, or for linear transportation projects, the *NCDOT Sediment and Erosion Control Manual*. All devices shall be maintained on all construction sites, borrow sites, and waste pile (spoil) sites, including contractor-owned or leased borrow pits associated with the project. Sufficient materials required for stabilization and/or repair of erosion control measures and stormwater routing and treatment shall always be on site. For borrow pit sites, the erosion and sediment control measures shall be designed, installed, operated, and maintained in accordance with the most recent version of the *North Carolina Surface Mining Manual*. Reclamation measures and implementation shall comply with the reclamation in accordance with the requirements of the Sedimentation Pollution Control Act and the Mining Act of 1971.
 17. Sediment and erosion control measures shall not be placed in wetlands or surface waters or within 5 feet of the top of the bank without prior approval from DWR. [15A NCAC 02H.0506(b); 15A NCAC 02H .0507(c)]
 18. The permittee shall use Design Standards in Sensitive Watersheds (15A NCAC 4B.0124[a]-[e]) in areas draining ORW, HQW waters. [15A NCAC 02H .0506(b); 15A NCAC 02H .0507(c)]



19. Erosion control matting in riparian areas shall not contain a plastic or nylon mesh grid which can impinge and entrap small animals. Matting should be secured in place by staples, stakes, or wherever possible live the stakes of native trees. Riparian areas are defined as a distance 25 feet from top of the stream bank. [15A NCAC 02H .0506(b); 15A NCAC 02H .0507(c)]
20. If placement of sediment and erosion control devices in wetlands and waters is unavoidable, then design and placement of temporary erosion control measures shall not be conducted in a manner that may result in dis-equilibrium of wetlands, stream beds, or banks, adjacent to or upstream and downstream of the above structures. All sediment and erosion control devices shall be removed from wetlands and waters and the natural grade restored within two (2) months of the date that the Division of Energy, Mining and Land Resources (DEMLR) or locally delegated program has released the specific area within the project. [15A NCAC 02H .0506(b); 15A NCAC 02H .0507(c); 15A NCAC02B .0200; 15A NCAC 02B .0231]
21. Any rip-rap required for proper culvert placement, stream stabilization, or restoration of temporarily disturbed areas shall be restricted to the area directly impacted by the approved construction activity. All rip-rap shall be placed such that the original streambed elevation and streambank contours are restored and maintained and shall consist of clean rock or masonry material free of debris or toxic pollutants. Placement of rip-rap or other approved materials shall not result in de-stabilization of the stream bed or banks upstream or downstream of the area or be installed in a manner that precludes aquatic life passage. [15A NCAC 02H .0506(b); 15A NCAC 02H .0507(c)]
22. The use of rip-rap above the Normal High-Water Mark shall be minimized. Any rip-rap placed for stream stabilization shall be placed in stream channels in such a manner that it does not impede aquatic life passage. [15A NCAC 02H.0506(b)(2)]
23. No drill slurry or water that has been in contact with uncured concrete shall be allowed to enter surface waters. This water shall be captured, treated, and disposed of properly. [15A NCAC 02H.0506(b)(3)]
24. NCDOT shall be in compliance with the NCS00250 issued to the NCDOT, including the applicable requirements of the NCG01000.
25. Native riparian vegetation must be reestablished in the riparian areas within the construction limits of the project by the end of the growing season following completion of construction. [15A NCAC 02B.0506(b){2}]
26. Discharging hydroseed mixtures and washing out hydro seeders and other



equipment in or adjacent to surface waters is prohibited. [15A NCAC 02H.0506(b)(2)]

27. The permittee and its authorized agents shall conduct its activities in a manner consistent with State water quality standards (including any requirements resulting from compliance with §303(d) of the Clean Water Act) and any other appropriate requirements of State and Federal law. If the NCDWR determines that such standards or laws are not being met (including the failure to sustain a designated or achieved use) or that State or federal law is being violated, or that further conditions are necessary to assure compliance, the NCDWR may reevaluate and modify this certification. [15A NCAC 02H .0506(b); 15A NCAC 02H .0507(c)]
28. The Permittee shall report any violations of this certification to the Division of Water Resources within 24 hours of discovery. [15A NCAC 02H .0506(b); 15A NCAC 02H .0507(c)]
29. Upon completion of the project (including any impacts at associated borrow or waste sites), the NCDOT Division Engineer shall complete the "Certification of Completion Form" to notify the NCDWR when all work included in the 401 Certification has been completed. [15A NCAC 02H.0507(c)]
30. A copy of this Water Quality Certification shall be always maintained on the construction site. In addition, the Water Quality Certification and all subsequent modifications, if any, shall be maintained with the Division Engineer and the on-site project manager. [15A NCAC 02H.0507(c) and 15A NCAC 02H .0506 (b)]

This Certification shall become null and void unless the above conditions are made conditions of the Federal 404 and/or Coastal Area Management Act Permit. This Certification shall expire upon the expiration of the 404 or CAMA permit. Please be aware that impacting waters without first applying for and securing the issuance of a 401 Water Quality Certification violates Title 15A of the North Carolina Administrative Code (NCAC) 2H .0500. Title 15A NCAC 2H .0500 requires certifications pursuant to Section 401 of the Clean Water Act whenever construction or operation of facilities will result in a discharge into navigable waters, including wetlands, as described in 33 Code of Federal Regulations (CFR) Part 323. It also states any person desiring issuance of the State certification or coverage under a general certification required by Section 401 of the Federal Water Pollution Control Act shall file with the Director of the North Carolina Division of Water Quality. Violations of any condition herein set forth may result in the revocation of this Certification and may result in criminal and/or civil penalties. Pursuant to G.S. 143-215.6A, these violations and any future violations are subject to a civil penalty assessment of up to a maximum of \$25,000.00 per day for each violation.

This approval and its conditions are final and binding unless contested [G.S. 143-215.5]. Please be aware that impacting waters without first applying for and securing the issuance of a 401 Water Quality Certification violates Title 15A of the North Carolina Administrative Code (NCAC) 2H .0500. Title 15A NCAC 2H .0500 requires certifications pursuant to Section 401 of the Clean Water Act whenever



construction or operation of facilities will result in a discharge into navigable waters, including wetlands, as described in 33 Code of Federal Regulations (CFR) Part 323. It also states any person desiring issuance of the State certification or coverage under a general certification required by Section 401 of the Federal Water Pollution Control Act shall file with the Director of the North Carolina Division of Water Quality. Pursuant to G.S. 143-215.6A, these violations and any future violations are subject to a civil penalty assessment of up to a maximum of \$25,000.00 per day for each violation.

This Certification can be contested as provided in Chapter 150B of the North Carolina General Statutes by filing a Petition for a Contested Case Hearing (Petition) with the North Carolina Office of Administrative Hearings (OAH) within sixty (60) calendar days. Requirements for filing a Petition are set forth in Chapter 150B of the North Carolina General Statutes and Title 26 of the North Carolina Administrative Code. Additional information regarding requirements for filing a Petition and Petition forms may be accessed at <http://www.ncoah.com/> or by calling the OAH Clerk's Office at (919) 431-3000.

A party filing a Petition must serve as a copy of the Petition on:

Dan Hirschman, General Counsel
Department of Environmental Quality
1601 Mail Service Center
Raleigh, NC 27699-1601

If the party filing the Petition is not the permittee, then the party must also serve the recipient of the Certification in accordance with N.C.G.S 150B-23(a).

This the 4th day of March 2026
DIVISION OF WATER RESOURCES

Signed by:

Faith Hardin

3185423002EA45E...

Faith Hardin, Supervisor
401 & Buffer Transportation Permitting Branch

WQC No.8705



JOSH STEIN
Governor
D. REID WILSON
Secretary
RICHARD E. ROGERS, JR.
Director



March 4, 2026

DWR # 20250132 v2
Beaufort County

Ms. Catherine Hossack Meyer
NCDOT Division 2
1037 W.H. Smith Blvd.
Greenville, NC 27835
cahossackmeyer@ncdot.gov

Subject: RENEWAL APPROVAL of TAR-PAMLICO Riparian Buffer Impacts with Additional Conditions FOR NCDOT (TIP # BR-0004 or Replacement of Bridge No. 66 over the Pungo River at Beaufort County. Pungo River TAR0729 34-(5), NSW, SC

Dear Ms. Meyer:

You have our approval for the impacts listed below for the purpose described in your application dated March 4, 2026, received by the Division of Water Resources (Division) on January 30, 2026. These impacts are covered by the **Tar-Pamlico** Buffer Rules and the conditions listed below. Please note that you should get any other federal, state or local permits before proceeding with your project, including those required by (but not limited to) Sediment and Erosion Control, Non-Discharge, and Water Supply Watershed regulations.

The following impacts are hereby approved, provided that all of the Conditions listed below and all of the conditions of the **Tar-Pamlico** Buffer Rules are met. No other impacts are approved, including incidental impacts. [15A NCAC 02B.0611(b)(2)].

Tar-Pamlico Riparian Buffer Impacts

Site	Zone 1 Impact (sq ft)		Zone 2 Impact (sq ft)
1	7984		4283
Totals	7984		4283

Total Buffer Impact for Project: 12, 227 square feet.

This approval is for the purpose and design described in your application. The plans and specifications for this project are incorporated by reference as part of this Authorization Certificate. If you change your project, you must notify the Division, and you may be required to submit a new application



package. If the property is sold, the new owner must be given a copy of this Authorization Certificate and is responsible for complying with all conditions. [15A NCAC 02B.0611(b)(2)].

If you are unable to comply with any of the conditions below, you must notify the Washington Regional Office within 24 hours (or the next business day if it is a weekend or holiday) from the time the permittee becomes aware of the circumstances.

The permittee shall report to the Washington Regional Office any noncompliance with the conditions of this Authorization Certificate and/or any violation of state regulated riparian buffer rules [15A NCAC 02B.0734. Information shall be provided orally within 24 hours (or the next business day if it is a weekend or holiday) from the time the applicant became aware of the circumstances.

Additional Conditions:

1. NCDOT will conduct a pre-construction meeting with all appropriate staff to ensure that the project supervisor and essential staff understand the permit conditions and any potential issues at the permitted site. NCDWR staff shall be invited to the pre-construction meeting. [15A NCAC 02H .0506{b}; 15A NCAC 02H .0507{c}]
2. The issuance of this certification does not exempt the Permittee from complying with all statutes, rules, regulations, or ordinances that may be imposed by other government agencies (i.e. local, state, and federal) having jurisdiction, including but not limited to applicable buffer rules, stormwater management rules, soil erosion and sedimentation control requirements, etc.
3. All stormwater runoffs shall be directed as sheet flow through stream buffers at non-erosive velocities, unless otherwise approved by this certification. [15A NCAC 02B. 0734 (9)]
4. All riparian buffers impacted by the placement of temporary fill or clearing activities shall be restored to the preconstruction contours and revegetated. Maintained buffers shall be permanently revegetated with non-woody species by the end of the growing season following completion of construction. For the purpose of this condition, maintained buffer areas are defined as areas within the transportation corridor that will be subject to regular Department of Transportation maintenance activities including mowing. The area with non-maintained buffers shall be permanently revegetated with native woody species before the next growing season following completion of construction. [15A NCAC 02B. 0734 (11) (ee)]
5. Pursuant to 15A NCAC 2B.0734 **sediment** and erosion control devices shall not be placed in Zone 1 of any **Tar-Pamlico** Buffer without prior approval by the NCDWR. At this time, the NCDWR has approved no sediment and erosion control devices in Zone 1, outside of the approved project impacts, anywhere on this project. Moreover, sediment and erosion control devices shall be allowed in Zone 2 of the buffers provided that Zone 1 is not compromised and that discharge is released as diffuse flow.
6. This approval is associated with General Water Quality Certification No. 4135 that was renewed on March 4, 2026 for the subject activity.

This approval and its conditions are final and binding unless contested. [G.S. 143-215.5]

This Authorization Certificate can be contested as provided in Chapter 150B of the North Carolina General Statutes by filing a Petition for a Contested Case Hearing (Petition) with the North Carolina Office of Administrative Hearings (OAH) within sixty (60) calendar days. Requirements for filing a Petition are set forth in Chapter 150B of the North Carolina General Statutes and Title 26 of the North Carolina Administrative Code. Additional information regarding requirements for filing a Petition and Petition forms may be accessed at <http://www.ncoah.com/> or by calling the OAH Clerk's Office at (919) 431-3000.



A party filing a Petition must serve as a copy of the Petition on:

Dan Hirschman, General Counsel
Department of Environmental Quality
1601 Mail Service Center
Raleigh, NC 27699-1601

If the party filing the Petition is not the permittee, then the party must also serve the recipient of the Certification in accordance with N.C.G.S 150B-23(a).

This Authorization shall expire five (5) years from the date of this letter.

This letter completes the review of the Division under the Tar- Pamlico Riparian Buffer Rules as described in 15A NCAC 02B.0734. Please contact Paul Nyarko on 252-948-3917 at paul.nyarko@deq.nc.gov if you have any questions or concerns.

Sincerely,

Signed by:

3185423002EA45E...
Faith Hardin, Supervisor
401 & Buffer Transportation Permitting Branch

cc:

Travis Wilson, NC Wildlife Resources Commission
Kyle Barnes, US Army Corps of Engineers, Washington Field Office
Chris Rivenbark, RK&K, crivenbark@rkk.com
Stephen Lane, NC Division of Coastal Management
Jason Elliott, NCDOT, Natural Environment Section
Paul Nyarko, NC Division of Water Resources Regional Office
DWR Transportation 401 & Buffer Permitting Branch electronic file



Permit Class
NEW

Permit Number
78-25

STATE OF NORTH CAROLINA
Department of Environmental Quality
and
Coastal Resources Commission

Permit

for

Major Development in an Area of Environmental Concern
pursuant to NCGS 113A-118

Excavation and/or filling pursuant to NCGS 113-229

Issued to N.C. Department of Transportation, 1598 Mail Service Center, Raleigh, NC 27699-1598

Authorizing development in Beaufort/Hyde County at Pungo River, Bridge No. 66 on US 264

as requested in the permittee's application dated 1/31/25, including the attached workplan drawings (27): 20 dated 1/31/25; and 7 dated as received on 5/19/25 & also dated 1/31/25.

This permit, issued on July 11, 2025, is subject to compliance with the application (where consistent with the permit), all applicable regulations, special conditions and notes set forth below. Any violation of these terms may be subject to fines, imprisonment or civil action; or may cause the permit to be null and void.

TIP No. BR-0004, Bridge Replacement and Associated Activities

- 1) In order to maintain navigation during construction and demolition, and in accordance with commitments made by the permittee, the authorized temporary work bridges shall be elevated to a minimum vertical clearance of 6 feet above the normal water level to match the low steel of the existing bridge, and at least one span of the temporary work bridge shall align with Span 8 of the existing bridge to facilitate navigation, as depicted on the attached workplan drawings. [07J .0202(c)].
- 2) All construction and demolition access shall be through the use of the existing bridge, the partially constructed new bridge, temporary work bridges, platforms, barges, existing causeway road from the bridge that was there before the existing bridge, and/or existing high ground areas. [07J .0202(c)].

(See attached sheets for Additional Conditions)

This permit action may be appealed by the permittee or other qualified persons within twenty (20) days of the issuing date.

This permit must be accessible on-site to Department personnel when the project is inspected for compliance.

Any maintenance work or project modification not covered hereunder requires further Division approval.

All work must cease when the permit expires on

No expiration date, pursuant to GS 136-44.7B

In issuing this permit, the State of North Carolina agrees that your project is consistent with the North Carolina Coastal Management Program.

Signed by the authority of the Secretary of DEQ and the Chair of the Coastal Resources Commission.



for Tancred Miller, Director
Division of Coastal Management

This permit and its conditions are hereby accepted.

DocuSigned by:
Catherine Hossack Meyer
BE9B38DC877140F...

07/14/2025

NCDOT

Signature of Permittee

ADDITIONAL CONDITIONS

- 3) The installation and/or the removal of the piles and other components for the new bridge, temporary work bridges, and/or existing bridge including abandoned bridge abutment in the Southwest quadrant, shall be accomplished by pile driving, vibratory hammer, static pull, and/or drilled shaft construction. Should the permittee and/or their contractor propose to utilize another type of installation or removal, such as jetting, additional authorization from DCM shall be required. [07J .0202(c); 07J .0405(a)].
- 4) Barges shall be utilized only in areas of sufficient depth such that the barges avoid contact with the bottom and do not rest on the bottom during periods of low water. [07J .0201].
- 5) The existing bridge, including the abandoned bridge abutment in the Southwest quadrant, temporary work bridges, as well as any remnant piles and/or structures, shall be removed within their entirety within 90 days after they are no longer needed and disposed of and/or recycled at an approved high ground site. [07H .0208(a)(2)].
- 6) If a piling or other component breaks during removal and cannot be removed in its entirety, it may be cut off flush with the bed of the water body, and DCM shall be notified of each occurrence within one working day. [07H .0208(a)(2)].
- 7) All wetland material from hollow temporary work trestle pilings shall remain in place to the maximum extent practicable or shall be stored on-site, to minimize and/or be used to restore wetland and open water impacts. [07H .0208(a)(2)].
- 8) No excavation or filling shall take place at any time in any vegetated wetlands or surrounding waters outside of the alignment of the areas indicated on the attached workplan drawings, without permit modification. [G.S 113A-120(b); 07J .0209(a); 07J .0405(a)].
- 9) All fill material shall be clean and free of any pollutants except in trace quantities. [07H .0208(a)(2)(B)].
- 10) Material excavated at the project site may be used in fill areas associated with the project once properly dewatered or shall be removed from the site and taken to a high ground location. [07H .0208(a)(2)].
- 11) All excavated materials shall be confined landward of normal water level and any regularly or irregularly flooded vegetated wetlands within adequate dikes or other retaining structures to prevent spillover of solids or seepage of effluent into any vegetated wetlands or surrounding waters. [07H .0208(a)(2)(B)].
- 12) The temporary placement and/or double handling of any excavated or fill material within wetlands or waters of the State is not authorized, with the exception of the temporary fill within hand clearing areas for erosion control measures. [07H .0208(a)(2)(B)].
- 13) All reasonable efforts shall be made to contain all debris and excess materials associated with the authorized activities, with the intent that materials/debris do not enter wetlands or waters of the State, even temporarily. [07H .0208(a)(2)(B)].

ADDITIONAL CONDITIONS

- 14) The placement of riprap shall be limited to the areas as indicated on the attached workplan drawings. It shall be of a size sufficient to prevent its movement from the authorized alignment by wave or current action. If the riprap becomes dislodged from the approved alignment at any point in the future, the permittee shall immediately contact DCM to determine the appropriate course of action. The riprap material shall consist of clean rock or masonry materials such as but not limited to granite, marl, or broken concrete without exposed rebar, or other suitable materials approved by DCM. [07J .0202(c)].
- 15) No drill slurry, uncured concrete or water that has been in contact with uncured concrete shall be allowed to contact waters of the State, or water that will enter waters of the State. Drilling fluids shall be disposed of in an upland disposal site. Water returning to the river shall be of sufficient quality so as to not pose a threat to aquatic organisms or otherwise violate State water quality standards. [07H .0208(a)(2)(B)].
- 16) Construction staging areas shall be located only in upland areas, outside of any applicable riparian buffers, and not in wetlands or waters of the State. [07H .0208(a)(2)(B)].
- 17) The demolition plan for removal of the existing bridge shall be submitted to DCM for review and approval prior to commencement of the demolition activities. [07J .0201].
- 18) Any waste materials or debris generated in the construction, demolition and removal of the existing bridge, temporary work bridges, and/or construction of the new structures shall be disposed of at an approved upland site or shall be recycled in an environmentally appropriate manner provided appropriate authorizations are obtained from any relevant state, federal, or local authorities. [G.S 113A-120(b); 07J .0209(a)].

Impacts to Wetlands and Waters of the State, and Tar-Pamlico Riparian Buffers

NOTE: This project will permanently impact approximately 24,834 square feet (0.57 acres) of Coastal Wetlands [approximately 17,755 square feet (0.40 acres) due to permanent fill and approximately 7,079 square feet (0.17 acres) due to excavation]. This project will temporarily impact approximately 18,195 square feet (0.42 acres) of Coastal Wetlands [approximately 13,765 square feet (0.32 acres) due to hand clearing, and approximately 4,430 square feet (0.10 acres) due to temporary excavation]. Utility relocations associated with this project will permanently impact approximately 200 square feet of Coastal Wetlands due to excavation.

NOTE: This project will permanently impact approximately 15,289 square feet (0.35 acres) of non-tidal riparian wetlands due to fill. This project will temporarily impact approximately 4,744 square feet (0.11 acres) of non-tidal riparian wetlands due to hand clearing.

NOTE: This project will permanently impact approximately 0.05 acres of surface waters and will temporarily impact approximately 1.28 acres of surface waters.

NOTE: This project will permanently impact approximately 12,227 square feet of Tar-Pamlico Riparian Buffers.

- 19) There shall be no clearing of wetlands outside of the areas indicated for impacts on the attached workplan drawings without prior approval from DCM. [07H .0208(a)(2)(B)].

ADDITIONAL CONDITIONS

- 20) Wetland areas to be temporarily impacted by clearing shall not be grubbed. [07H .0208(a)(2)(B)].
- 21) The permittee shall minimize the need to cross wetlands in transporting equipment to the maximum extent practicable. [07H .0208(a)(2)(B)].
- 22) Construction mats shall be utilized to support equipment within wetland areas to minimize temporary wetland impacts. The mats shall be removed immediately following completion of the project. [07H .0208(a)(2)(B)].
- 23) Any voids in Coastal Wetlands or shallow bottom habitat caused by the removal of the temporary work bridges shall be restored to the elevation of the pre-existing conditions with suitable material. The permittee shall notify DCM's Transportation Field Representative in Morehead City to provide DCM with an opportunity to inspect the material for suitability prior to backfilling. [07H .0208(a)(2)].
- 24) In accordance with commitments made by the permittee, fill slopes in Coastal Wetlands on the east side of the Pungo River shall be 1.5:1 or steeper, as depicted on the attached workplan drawings. [07H .0205].
- 25) Due to the possibility that compaction, hand clearing, temporary fill, and/or other site alterations might prevent the temporary Coastal Wetland impact areas from re-attaining pre-project wetland functions, the permittee shall provide an annual update on the Coastal Wetland areas temporarily impacted by this project. This annual update shall consist of photographs and a brief written report on the progress of these temporarily impacted areas in re-attaining their pre-project wetland functions. The permittee shall schedule a meeting with DCM to verify the extent and location of temporary impacts upon project completion. Within three years after project completion, the permittee shall hold another agency field meeting with DCM to determine if the Coastal Wetland areas temporarily impacted by this project have re-attained pre-project wetland functions. If at the end of three years DCM determines that the Coastal Wetland areas temporarily impacted by the project have not re-attained pre-project wetland functions, DCM will determine whether compensatory wetland mitigation shall be required. [07H .0208(a)(3)].

Compensatory Mitigation for Wetland Impacts

- 26) Unless specifically altered herein, on-site mitigation shall be carried out as described in the document titled "Onsite Wetland Mitigation Plan, Replace Bridge No. 66 on US 264 over Pungo River, Beaufort and Hyde Counties, NC" dated January 20, 2025. Any changes to the mitigation plan authorized by this CAMA permit shall require additional DCM authorization. [07H .0208(a)(3)].

NOTE: The on-site mitigation is expected to restore approximately 0.68 acres of existing high ground area to Coastal Wetland elevations and will be planted with appropriate Coastal Wetland species. The on-site mitigation also includes restoration of approximately 0.42 acres of existing high ground area to Section 404 Wetland elevations and planted with appropriate species.

NOTE: The on-site mitigation plan includes the Coastal Wetlands Coastal Area Management Act (CAMA) Area of Environmental Concern (AEC), and other Section 404 Wetlands. DCM's comments and conditions pertain to compensatory mitigation for the Coastal Wetlands CAMA AEC. The N.C. Division of Water Resources has statutory authority to review and approve compensatory mitigation for other Section 404 Wetlands.

ADDITIONAL CONDITIONS

- 27) The authorized project includes approximately 4,430 square feet (0.10 acres) of impacts to Coastal Wetlands due to excavation in order to construct the wetland mitigation site. The permittee shall not receive mitigation credit for this area, and they shall not be required to provide mitigation for this impact. However, if areas where existing Coastal Wetlands are impacted in order to construct the mitigation site do not re-attain their pre-project wetland functions within 5 years of mitigation site construction, then the temporary impacts may be reclassified as permanent impacts and mitigation shall be required. [07H .0208(a)(3)].
- 28) The wetland mitigation areas shall be fully contained by silt fence and/or turbidity curtains until all of the unsuitable fill material has been removed and the mitigation areas have been restored to the approximate natural elevation of the adjacent, similar undisturbed wetlands and stabilized with appropriate wetland vegetation as specified in the authorized mitigation plan. [07H .0208(a)(2)].
- 29) An as-built survey report for the mitigation site shall be submitted to DCM within 60 days after the mitigation site has been constructed. [07J .0202(c)].
- 30) The permittee shall submit annual mitigation monitoring reports to DCM for a minimum of five years after mitigation site construction, or until mitigation success criteria are met. Annual monitoring reports shall include photographs and an assessment of whether the site is achieving success based on the success criteria stated in the mitigation plan. Progress reports shall also be provided upon request. The wetland site shall be deemed successful if the target wetland herbaceous species survives and has an average minimum of 75 percent vegetative cover, not including any invasive species. Monitoring may cease when the permittee can demonstrate that success criteria have been met and written concurrence is received from DCM. [07H .0208(a)(3)].
- 31) The onsite wetland mitigation sites shall be protected in perpetuity in their restored state and owned by the permittee or its approved designee. An appropriate conservation easement, deed restriction or other appropriate instrument shall be attached to the title for the subject property. Failure to adequately protect mitigation sites may result in further mitigation requirements. [07H .0208(a)(3)].
- 32) The wetland mitigation provided by this project shall not generate any excess mitigation credits for use on future projects. [07H .0208(a)(3)].

Historic, Cultural and Natural Resource Protection

- 33) The N.C. Department of Cultural and Natural Resources has identified a potential for cultural resources, such as sunken vessels, to be inadvertently discovered during this project. If the permittee discovers any previously unknown historic or archaeological resources while accomplishing the authorized work, they shall immediately stop work and notify DCM and the N.C. Department of Cultural and Natural Resources Underwater Archaeology Branch in Kure Beach to initiate the required coordination procedures. [07H .0208(a)(2)(C)].

ADDITIONAL CONDITIONS

NOTE: In accordance with commitments made by the permittee, in order to protect the endangered West Indian Manatee, *Trichechus manatus*, the permittee shall implement the U.S. Fish & Wildlife Service's Guidelines, and strictly adhere to all requirements therein. The guidelines can be found at http://www.fws.gov/nc-es/mammal/manatee_guidelines.pdf.

NOTE: The N.C. Natural Heritage Program submitted comments during the CAMA major permit application review stating that the NCNHP database indicates that there are records for rare species, important natural communities, natural areas, and/or conservation/managed areas within the proposed project boundary, including the Upper Pungo River Wetlands Natural Area.

Utility Impacts

NOTE: Construction of the new bridge will also require relocation of an existing fire hydrant and the associated water line, a power line pole, and telecommunication utilities.

34) Any utility work associated with this project that is not specifically depicted on the attached workplan drawings, or described within the attached permit application, shall require approval from DCM, either under the authority of this permit, or by the utility company obtaining separate authorization. [07J .0202(c); 07J .0201; 07J .0405(a)].

NOTE: The project proposes to relocate a water line owned by the Beaufort County Northside Regional Water System (NC0407035). Plans for the water line relocation should be submitted to and approved by the N.C. Division of Water Resources, Public Water Supply Section (1634 Mail Service Center, Raleigh, NC 27699-1634) prior to commencing work on the water line.

Sedimentation and Erosion Control

35) Turbidity curtains shall be used to isolate all in-water work areas from the adjacent waters of the Pungo River, including but not limited to installation and removal of bridge piles, including the abandoned bridge abutment in the Southwest quadrant, and temporary work bridges. The turbidity curtains shall encircle the immediate work area, however, they shall not impede navigation. The turbidity curtains shall be sufficient to prevent a visible increase in the amount of suspended sediments in adjacent waters. The turbidity curtains shall be properly maintained and retained in the water until construction is complete and shall only be removed when turbidity within the curtains reaches ambient levels. exercise[07H .0208(a)(2); 07H .0209(d)(4)].

36) This project shall conform to all requirements of the N.C. Sedimentation Pollution Control Act and the N.C. Department of Transportation's (NCDOT's) Memorandum of Agreement with the N.C. Division of Energy, Mineral and Land Resources. [07J .0209(a)].

37) In order to protect water quality, runoff from construction shall not visibly increase the amount of suspended sediments in adjacent waters. [07H .0209(d)(4); G.S. 113A-102(a); 07H .0208(a)(2)].

ADDITIONAL CONDITIONS

Stormwater Management

NOTE: This project shall be constructed in accordance with the permittee's Stormwater Management Plan dated 12/17/24, and the provisions of the NCDOT's National Pollutant Discharge Elimination (NPDES) Stormwater Permit NCS000250, including the application requirements of the NCG01000.

- 38) Bridge deck drains shall not directly discharge into the open waters of the Pungo River and shall not cause erosion of adjacent Coastal Wetlands. [07H .0208(a)(3)].

General

- 39) Throughout project construction and demolition, the permittee shall make every attempt to maintain the same public trust access and navigation that is currently possible in the Pungo River. If this is not possible, then adequate notice shall be provided to the public that navigation will be limited during construction and/or demolition. The notice shall include an estimate of the amount of time that the limited navigation will occur. [07H .0208(a)(2)(G)].
- 40) No attempt shall be made by the permittee to prevent the use by the public of all navigable waters at or adjacent to the authorized work following completion of construction. [07H .0208(a)(2)(G)].

NOTE: It is strongly recommended that the permittee exercise all available precautions in the construction, operation and maintenance of the bridge and adjacent roadway to prevent waste from entering the adjacent waters and wetlands. Such discharge, either directly or indirectly, to adjacent waters could contravene state water quality standards, thereby violating state law.

- 41) Development authorized by this permit shall only be conducted on lands owned by NCDOT, appropriate utility entities, and/or their Right-of-Ways and/or easements. [G.S. 113-229(b)].
- 42) If it is determined that additional permanent and/or temporary impacts are necessary that are not shown on the attached workplan drawings or described in the authorized permit application, additional authorization from DCM shall be required. In addition, any changes in the approved plan may also require additional authorization from DCM. The permittee shall contact a representative of DCM prior to commencement of any such activity for this determination and any permit modification. [07J .0201].
- 43) The permittee and/or their contractor shall contact the DCM Transportation Project Field Representative by phone at (252) 515-5408 or by email at stephen.lane@deq.nc.gov to request a preconstruction conference prior to project initiation. [G.S 113A-120(b); 07J .0209(a)].
- 44) The permittee shall install and maintain at their expense any signal lights or signals prescribed by the U.S. Coast Guard, through regulation or otherwise, on the authorized facilities. For further information, the permittee should contact the U.S. Coast Guard Marine Safety Office. At a minimum, permanent reflectors shall be attached to the structure in order to make it more visible during hours of darkness or inclement weather. [113-229(e)].

ADDITIONAL CONDITIONS

NOTE: A CAMA/Dredge and Fill Permit is a determination that the proposed development meets the CAMA/Dredge and Fill laws and CRC's rules for coastal development. It is not a determination of private property ownership or an authorization to trespass onto property owned by someone other than the Permittee.

NOTE: This permit action may be appealed by the permittee or other qualified persons within twenty (20) days of the issuing date. Any development authorized under this permit that occurs prior to the expiration of the twenty (20) day appeal period or completion of an appeal process, shall be done at the permittee's risk.

NOTE: The permittee is strongly advised to review and understand all additional permits, approvals or authorizations that may be required, including but not limited to any permits, approvals or authorizations provided by the N.C Division of Water Resources, U.S. Army Corps of Engineers, and other state and local regulatory agencies.

NOTE: The N.C. Division of Water Resources (DWR) authorized the proposed project on 3/21/25 (DWR Project No. 20250132) under General Water Quality Certification No. 4135, and under the Tar-Pamlico Riparian Buffer Rules.

NOTE: The U.S. Army Corps of Engineers authorized the proposed project under Regional General Permit Number 50 (COE Action ID No. SAW-2024-00712), which was issued on 3/20/25.

NOTE: This permit does not eliminate the need to obtain any additional permits, approvals or authorizations that may be required.

NOTE: An application processing fee of \$474 was received by DCM for this project. This fee also satisfied the Section 401 application processing fee requirements of DWR.



United States Department of the Interior

FISH AND WILDLIFE SERVICE

Raleigh Field Office

Post Office Box 33726

Raleigh, North Carolina 27636-3726

GUIDELINES FOR AVOIDING IMPACTS TO THE WEST INDIAN MANATEE

Precautionary Measures for Construction Activities in North Carolina Waters

The West Indian manatee (*Trichechus manatus*), also known as the Florida manatee, is a Federally-listed endangered aquatic mammal protected under the Endangered Species Act of 1973, as amended (16 U.S.C. 1531 *et seq.*) and the Marine Mammal Protection Act of 1972, as amended (16 U.S.C 1461 *et seq.*). The manatee is also listed as endangered under the North Carolina Endangered Species Act of 1987 (Article 25 of Chapter 113 of the General Statutes). The U.S. Fish and Wildlife Service (Service) is the lead Federal agency responsible for the protection and recovery of the West Indian manatee under the provisions of the Endangered Species Act.

Adult manatees average 10 feet long and weigh about 2,200 pounds, although some individuals have been recorded at lengths greater than 13 feet and weighing as much as 3,500 pounds. Manatees are commonly found in fresh, brackish, or marine water habitats, including shallow coastal bays, lagoons, estuaries, and inland rivers of varying salinity extremes. Manatees spend much of their time underwater or partly submerged, making them difficult to detect even in shallow water. While the manatee's principal stronghold in the United States is Florida, the species is considered a seasonal inhabitant of North Carolina with most occurrences reported from June through October.

To protect manatees in North Carolina, the Service's Raleigh Field Office has prepared precautionary measures for general construction activities in waters used by the species. Implementation of these measures will allow in-water projects which do not require blasting to proceed without adverse impacts to manatees. In addition, inclusion of these guidelines as conservation measures in a Biological Assessment or Biological Evaluation, or as part of the determination of impacts on the manatee in an environmental document prepared pursuant to the National Environmental Policy Act, will expedite the Service's review of the document for the fulfillment of requirements under Section 7 of the Endangered Species Act. These measures include:

- 1 The project manager and/or contractor will inform all personnel associated with the project that manatees may be present in the project area, and the need to avoid any harm to these endangered mammals. The project manager will ensure that all construction personnel know the general appearance of the species and their habit of moving about completely or partially submerged in shallow water. All construction personnel will be informed that they are responsible for observing water-related activities for the presence of manatees.
2. The project manager and/or the contractor will advise all construction personnel that there are civil and criminal penalties for harming, harassing, or killing manatees which are protected under the Marine Mammal Protection Act and the Endangered Species Act.

3. If a manatee is seen within 100 yards of the active construction and/or dredging operation or vessel movement, all appropriate precautions will be implemented to ensure protection of the manatee. These precautions will include the immediate shutdown of moving equipment if a manatee comes within 50 feet of the operational area of the equipment. Activities will not resume until the manatee has departed the project area on its own volition (i.e., it may not be herded or harassed from the area).

4. Any collision with and/or injury to a manatee will be reported immediately. The report must be made to the U.S. Fish and Wildlife Service (ph. 919-856-4520), the National Marine Fisheries Service (ph. 252-728-8762), and the North Carolina Wildlife Resources Commission (ph. 252-448-1546).

5. A sign will be posted in all vessels associated with the project where it is clearly visible to the vessel operator. The sign should state:

CAUTION: The endangered manatee may occur in these waters during the warmer months, primarily from June through October. Idle speed is required if operating this vessel in shallow water during these months. All equipment must be shut down if a manatee comes within 50 feet of the vessel or operating equipment. A collision with and/or injury to the manatee must be reported immediately to the U.S. Fish and Wildlife Service (919-856-4520), the National Marine Fisheries Service (252-728-8762), and the North Carolina Wildlife Resources Commission (252-448-1546).

6. The contractor will maintain a log detailing sightings, collisions, and/or injuries to manatees during project activities. Upon completion of the action, the project manager will prepare a report which summarizes all information on manatees encountered and submit the report to the Service's Raleigh Field Office.

7. All vessels associated with the construction project will operate at "no wake/idle" speeds at all times while in water where the draft of the vessel provides less than a four foot clearance from the bottom. All vessels will follow routes of deep water whenever possible.

8. If siltation barriers must be placed in shallow water, these barriers will be: (a) made of material in which manatees cannot become entangled; (b) secured in a manner that they cannot break free and entangle manatees; and, (c) regularly monitored to ensure that manatees have not become entangled. Barriers will be placed in a manner to allow manatees entry to or exit from essential habitat.

Prepared by (rev. 02/2017):
U.S. Fish and Wildlife Service
Raleigh Field Office
Post Office Box 33726
Raleigh, North Carolina 27636-3726
919/856-4520

Figure 1. The whole body of the West Indian manatee may be visible in clear water; but in the dark and muddy waters of coastal North Carolina, one normally sees only a small part of the head when the manatee raises its nose to breathe.

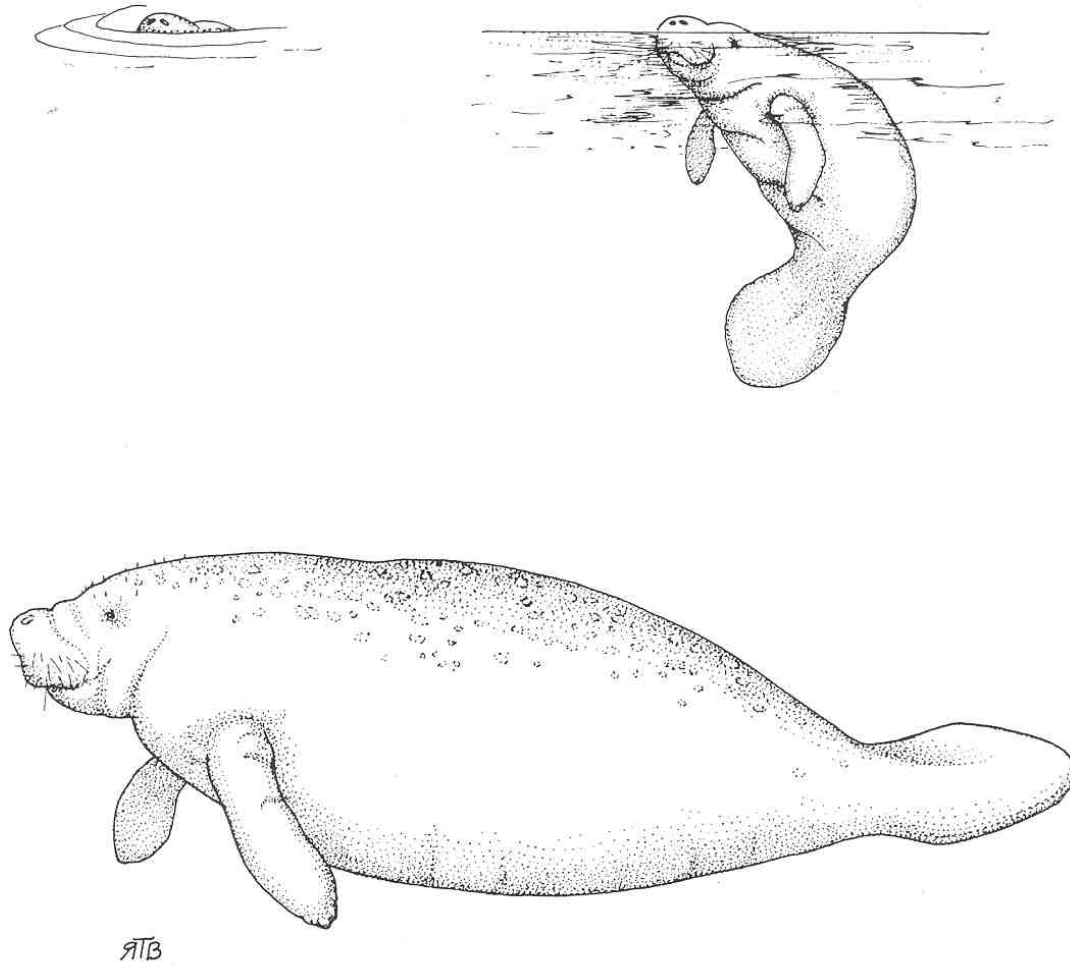

Illustration used with the permission of the North Carolina State Museum of Natural Sciences.

Source: Clark, M. K. 1987. Endangered, Threatened, and Rare Fauna of North Carolina: Part I. A re-evaluation of the mammals. Occasional Papers of the North Carolina Biological Survey 1987-3. North Carolina State Museum of Natural Sciences. Raleigh, NC. pp. 52.

U.S. Department of
Homeland Security

United States
Coast Guard



Commander
United States Coast Guard
Fifth Coast Guard District

431 Crawford Street
Portsmouth, VA 23704-5004
Staff Symbol: dpb
Phone: (757) 398-6629
Fax: (757) 398-6334
Email: Jack.H.Williams2@uscg.mil
or CGDFiveBridges@uscg.mil

16591
25 APR 2024

Ms. Catherine HossackMeyer
North Carolina Department of Transportation
1598 Mail Service Center
Raleigh, NC 27699

Dear Ms. HossackMeyer:

Coast Guard review of your proposed project as provided in an email dated April 15, 2024, from Mr. Chris Rivenbark with RK@K INC., on behalf of the bridge owner, is complete.

Based on the documentation provided and our research, it is determined that a Coast Guard Bridge Permit will not be required for the proposed highway fixed – US 264 Bridge across Pungo River, mile 23.0, at position 35.5715346, -76.5014267, between Beaufort and Hyde Counties, NC.

The project will be placed in our Advance Approval category as per Title 33 Code of Federal Regulations Part 115.70. This Advance Approval determination is for the location and structure described above and **is valid for five years from the date of this letter**. The following conditions apply to this determination:

- a. If the construction project on the above bridge does not commence within this time, you must contact this office for reaffirmation of this determination.
- b. Future bridge projects along the above waterway will have to be independently evaluated before they may be considered for placement in the Advance Approval category. This includes modification, replacement, and removal of the above bridge, following its initial construction.
- c. Prior to bridge construction, the bridge owner should submit a bridge maintenance project plan to this office at least 30 days (preferably 90 days) prior to work commencing on or over the navigable waterway. Please see enclosure (1).
- d. Please submit photographs and as-built drawings of both plan and elevation views of the bridge upon completion of the project. Plans should be in the standard 8 ½ x 11 inch format. The drawings, along with the enclosed Completion Report Form, must indicate the vertical clearance from ordinary high water to the lowest portion of the bridge and horizontal clearance, pier face to pier face, or bank to bank, in the main navigation span. Please see enclosures (2) and (3).

The fact that a Coast Guard bridge permit is not required does not relieve you of the responsibility for compliance with the requirements of any other Federal, State, or local agency who may have jurisdiction over any aspect of the project. Although the project will not require a bridge permit, other areas of Coast Guard jurisdiction apply. The following conditions apply concerning construction of the above bridge:

- a. You or your contractor must notify this office at least 30 days (preferably 90 days) in advance of the start of construction and any other work which may be an obstruction to navigation, so we may issue and update the information in our Local Notice to Mariners and monitor the project. The notice should include details of the project as described in enclosure (1).
- b. At no time during the project will the waterway be closed to navigation without the prior notification and approval of the Coast Guard. The bridge owner or contractor is required to maintain close and regular contact with Coast Guard Sector North Carolina at (910) 772-2230 or D05-SMB-SecNC-MarineEvents@uscg.mil to keep them informed of activities on the waterway.
- c. The lowest portion of the superstructure of the bridge across the waterway should clear the 100-year flood height elevation, if feasible.
- d. In addition, the requirement to display navigational lighting at the aforementioned bridge is hereby waived, as per Title 33 Code of Federal Regulations, Part 118.40(b). This waiver may be rescinded at any time in the future should nighttime navigation through the proposed bridge be increased to a level determined by the District Commander to warrant lighting.

If you have any further questions, please contact Mr. Jack H. Williams at the above listed address or telephone number.

Sincerely,

PITTS.HAL.R.
1121267272

Digitally signed by
PITTS.HAL.R.1121267272
Date: 2024.04.25 14:25:03
-04'00'

HAL R. PITTS
Bridge Program Manager
By direction

- Encl: (1) Bridge Maintenance Project Plan
(2) Bridge Completion Report (CG-4599)
(3) Plan Sheet Job Aid

Copy: CG Sector North Carolina, Waterways Management
U. S. Army Corps of Engineers, Wilmington District
Federal Highways Administration, Raleigh, NC

BRIDGE MAINTENANCE PROJECT PLAN

1. The bridge owner, or entity acting on behalf of the bridge owner, should submit a bridge maintenance project plan at least 30 days (preferably 90 days) prior to commencement of work on or over the navigable waterway. Correspondence may be submitted via .pdf email attachment to CGDFiveBridges@uscg.mil or mailed.
2. Once received, the request will be assigned to a project officer for review and processing. The project officer will publish a local notice to mariners. If appropriate, the project officer will publish a temporary deviation from drawbridge operating regulations.
 - a. Bridge Information: Provide bridge name, bridge type (highway, railroad, pedestrian, pipeline, etc.), roadway (s) carried, waterway name, mile (statute) on waterway from confluence, municipal location (town/city, county (if applicable/if known), and state).
 - b. Project Description: Provide the general description, nature and scope of the project. Drawings may be submitted, particularly if there are any planned temporary reductions in navigation clearances.
 - c. Project Dates/Work Hours: Provide primary and alternate (if applicable) project dates and work hours. Alternate dates and work hours may be included to account for inclement weather, etc.
 - d. Navigation Clearances: Provide any proposed temporary reductions in navigation clearances (vertical and/or horizontal), including the amount of the reduction (s) in feet and when the reduction (s) will be in place.
 - e. Temporary Deviation (from Operating Regulations): For drawbridges – Provide any proposed temporary deviation from operating regulations including: purpose (why it is necessary); dates/times of closure; if the bridge will be closed when bridge work is not being performed, provide justification for closure during non-work hours; whether the bridge will be able to open for an emergency and within how much time of notice; whether vessels may pass through the bridge in the closed position at any time or with prior notice.
 - f. Project Resources: Provide list of vessels, barges, equipment and location of personnel involved in the project. Indicate whether the project resources will relocate from the navigation channel during work hours, and if so, provide the timeframe for notice and method of notice. Indicate whether the resources will relocate from the navigation channel during non-work hours, and if not, provide justification for them to remain in the navigation channel during non-work hours.
 - g. Communications: Provide communications plan for project resources. This should include VHF-FM channel 13 for vessels and drawbridge tenders and may include mobile phone devices for vessels and project personnel. Vessel operators need to be able to communicate with project resources for safe navigation .
 - h. Bridge Owner Information: If the request is submitted by an entity on behalf of the bridge owner, provide the bridge owner representative's contact information (name, telephone and email) and the bridge owner's mailing address for the appropriate office.

Submitted 1/30/2026 for Reverification

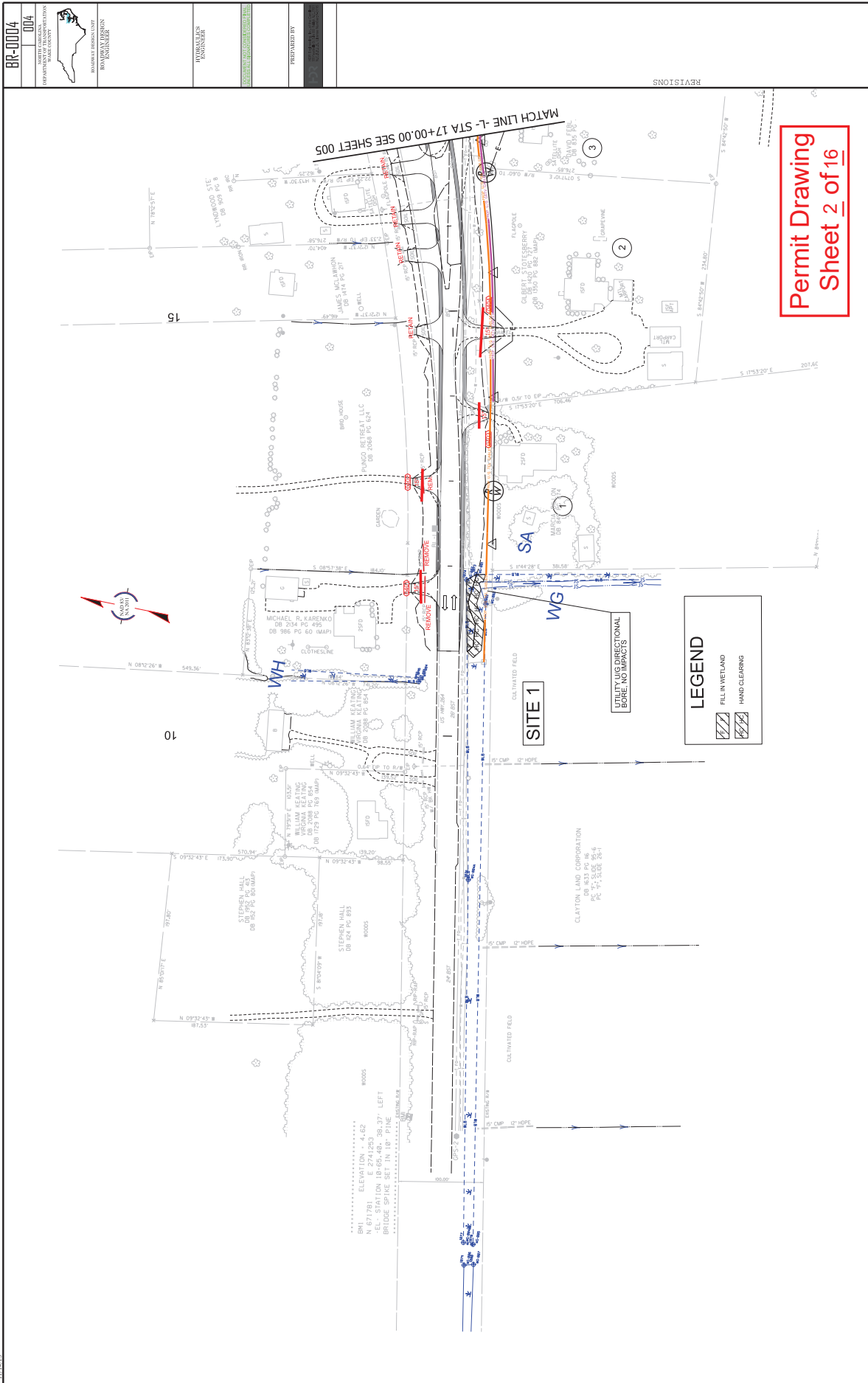

BR-0004	004	
DEPARTMENT OF TRANSPORTATION MARYLAND MARYLAND DESIGN ENGINEERS	MARYLAND DESIGN ENGINEERS MARYLAND DESIGN ENGINEERS	MARYLAND DESIGN ENGINEERS MARYLAND DESIGN ENGINEERS
MARYLAND DESIGN ENGINEERS MARYLAND DESIGN ENGINEERS	MARYLAND DESIGN ENGINEERS MARYLAND DESIGN ENGINEERS	MARYLAND DESIGN ENGINEERS MARYLAND DESIGN ENGINEERS

REVISIONS

Submitted 1/30/2026 for Reverification

11/14/23



100 X

BR-0004

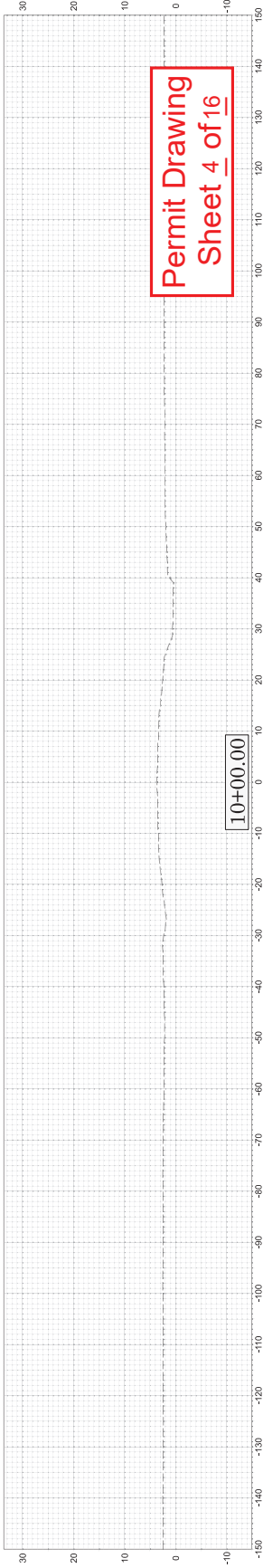
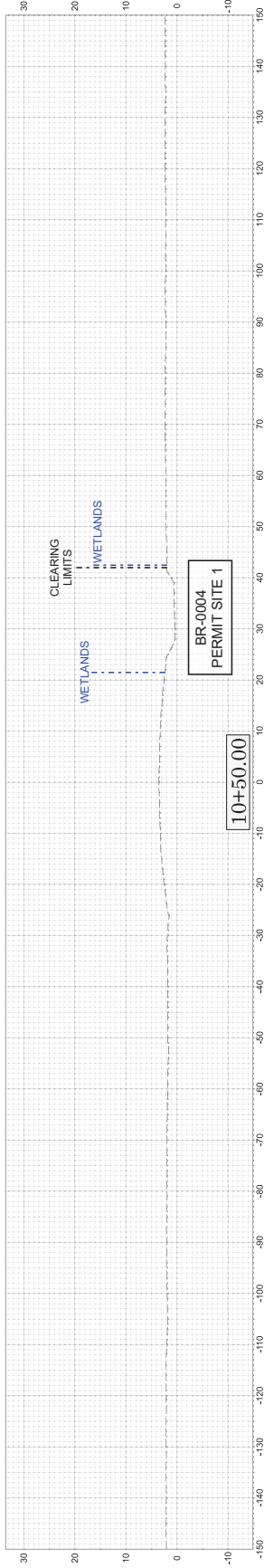
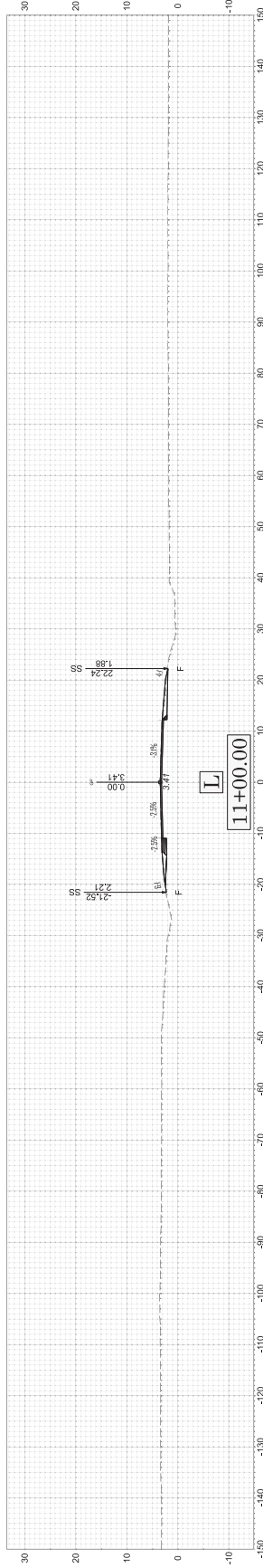

Permit Drawing Sheet 4 of 16

DATEPLOT/BOUND - 12/15/2024

Submitted 1/30/2026 for Reverification

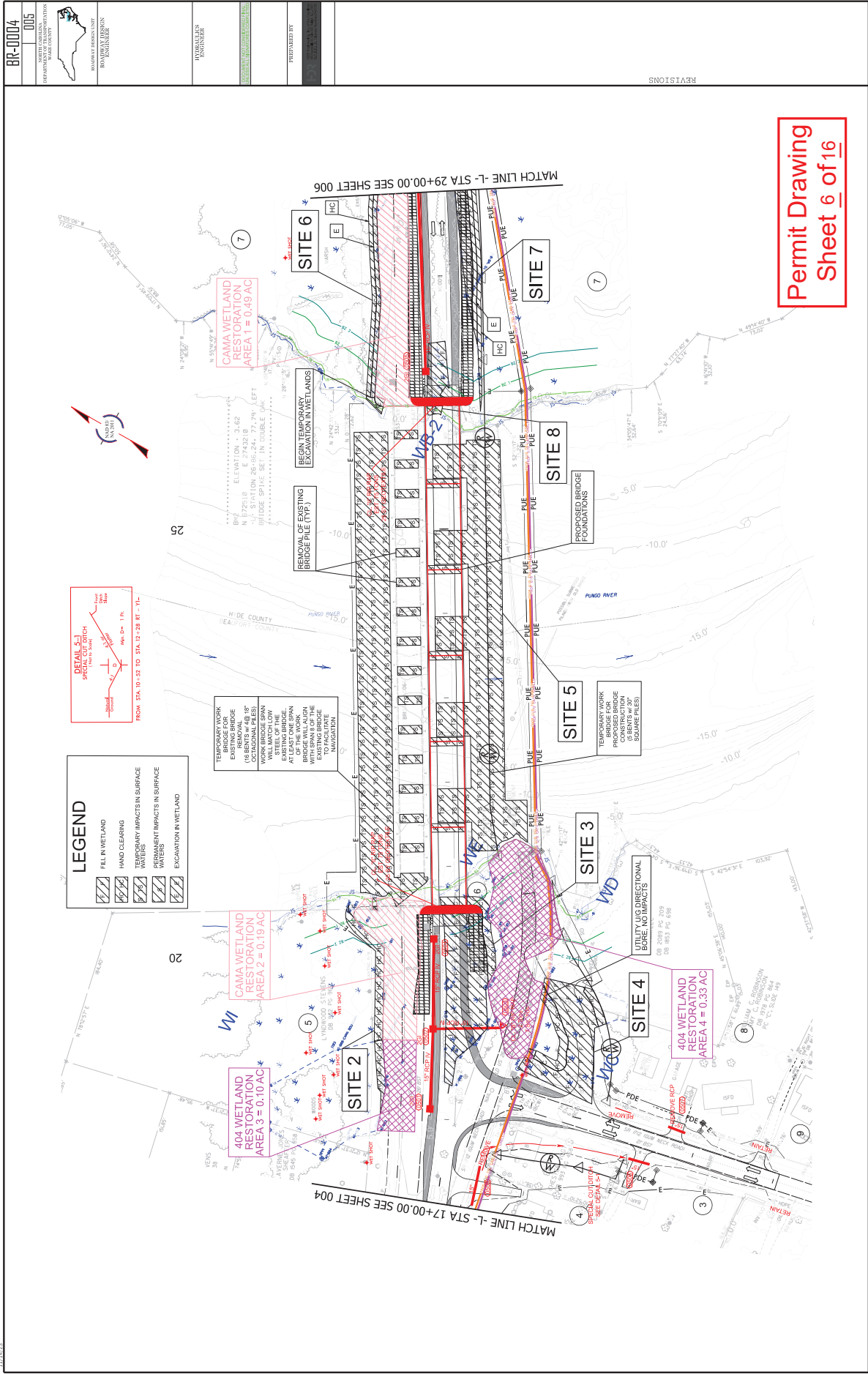

Submitted 1/30/2026 for Reverification

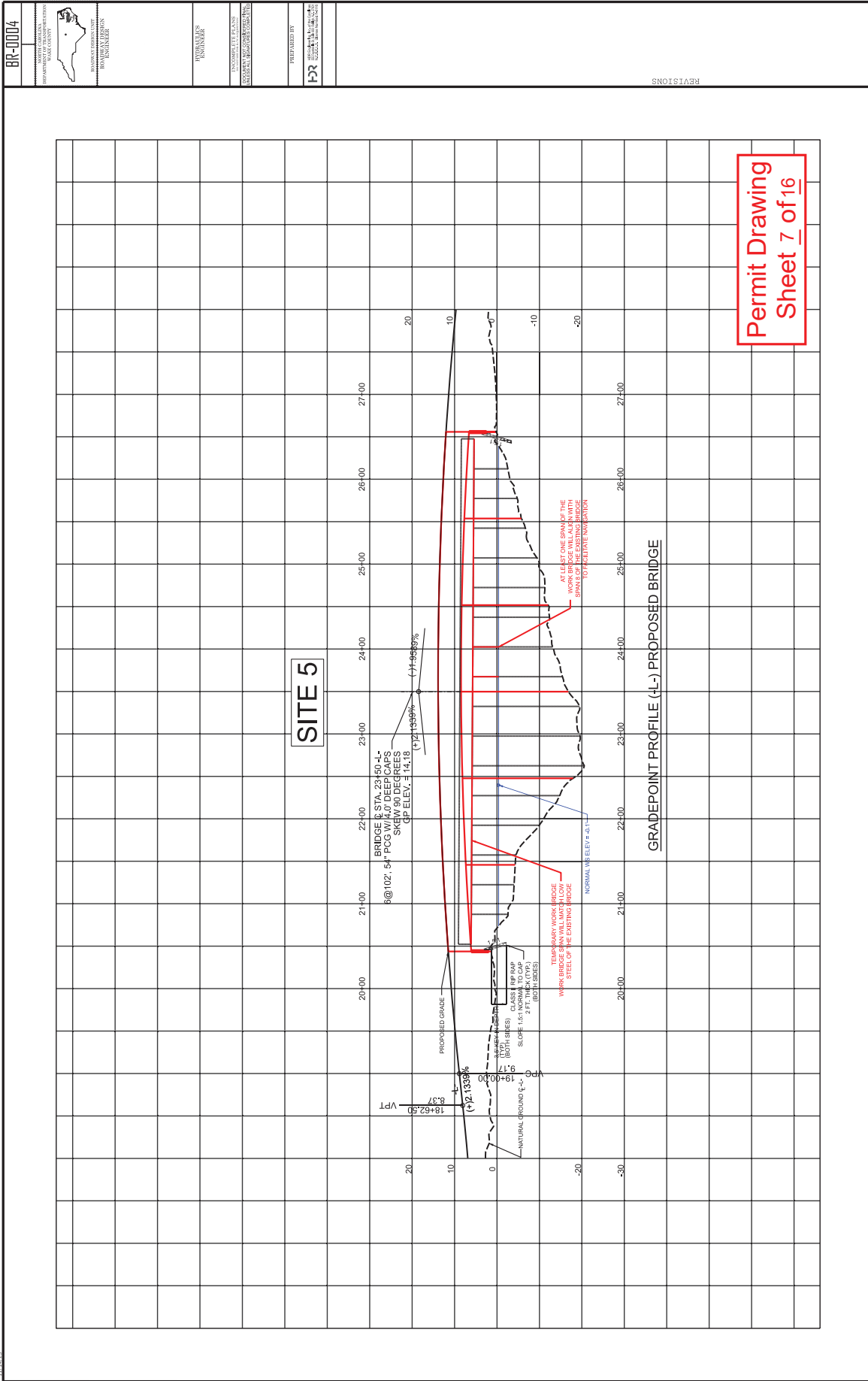

Submitted 1/30/2026 for Reverification

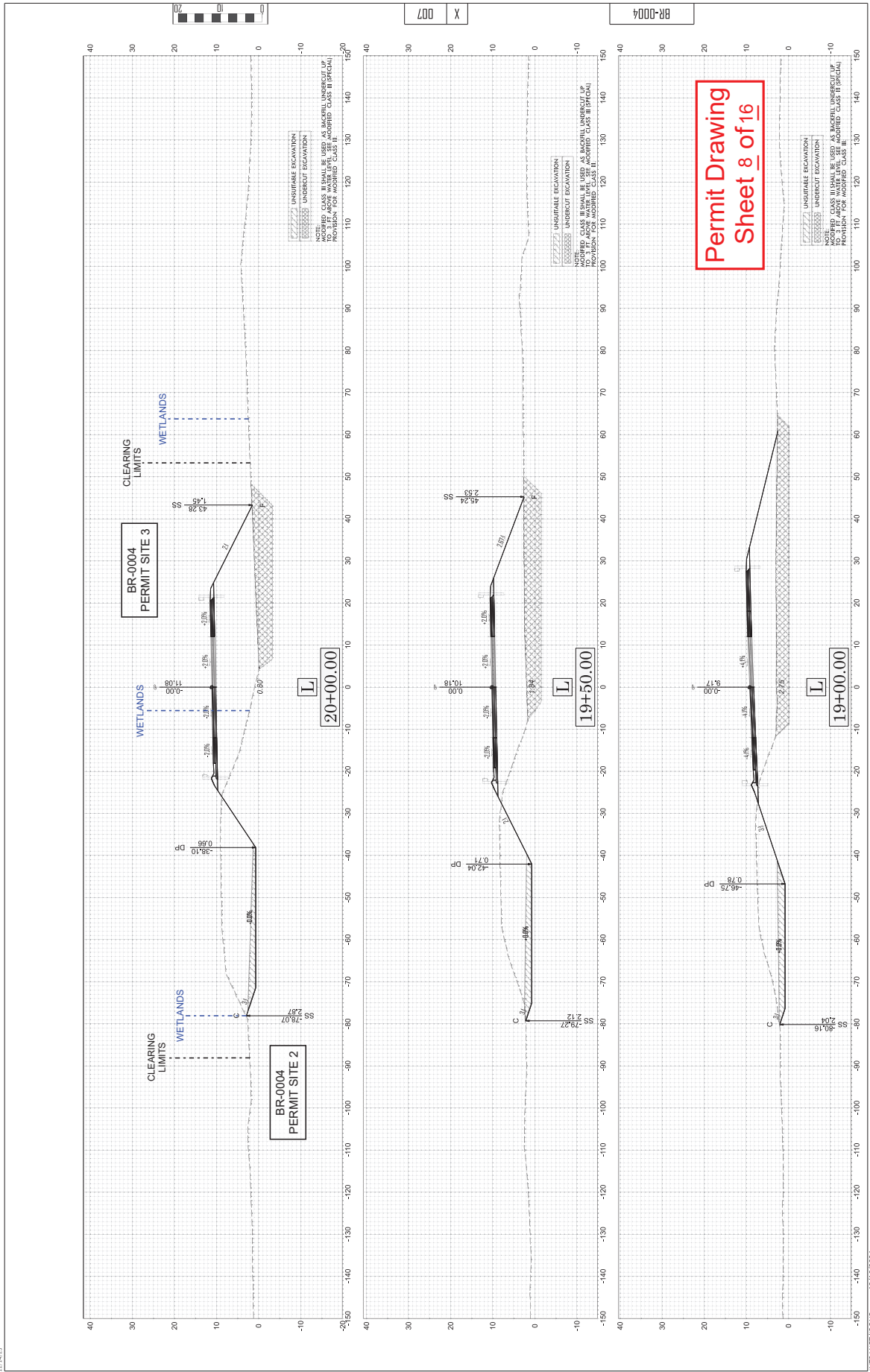

Submitted 1/30/2026 for Reverification

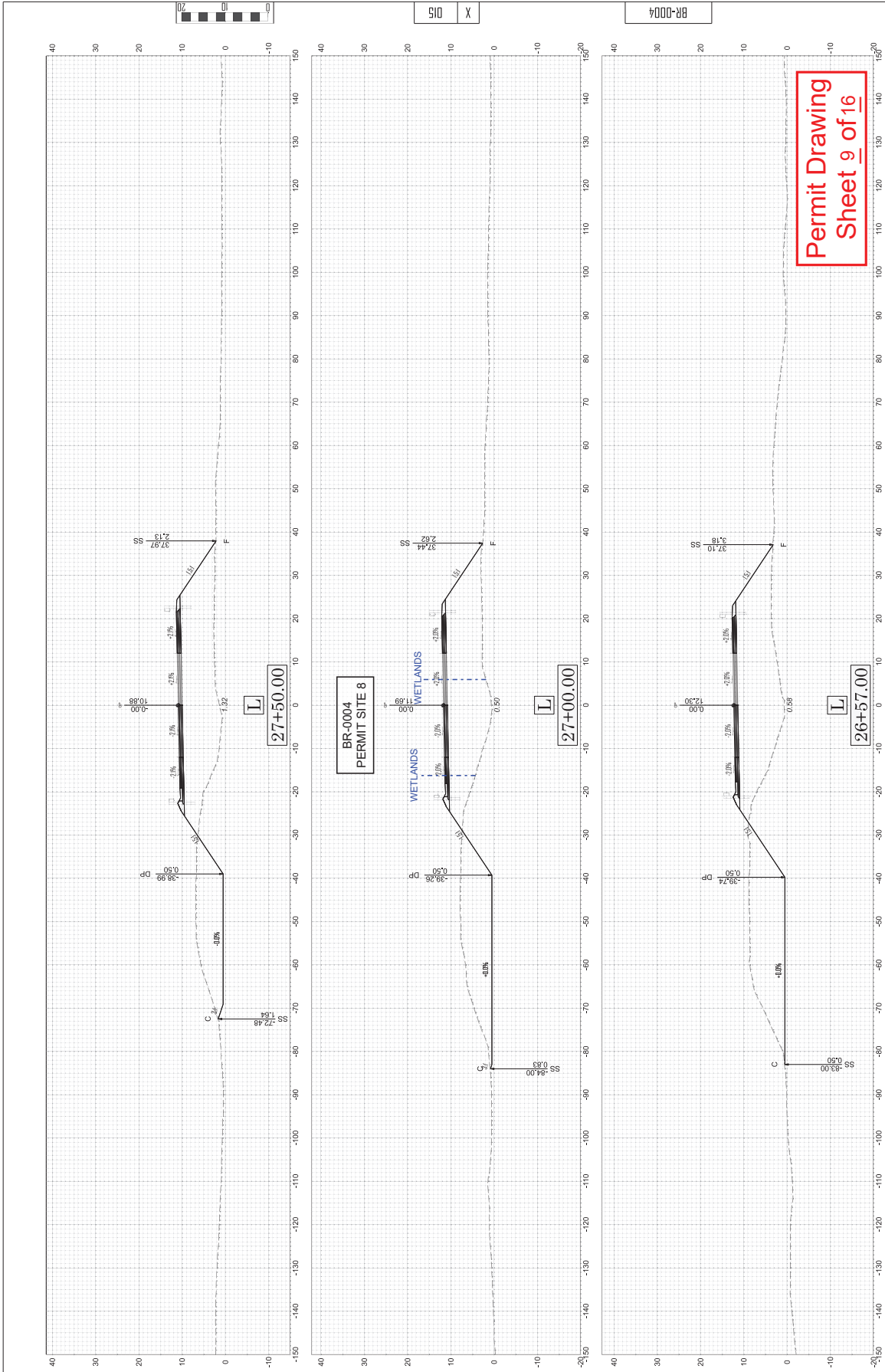

Submitted 1/30/2026 for Reverification

11/14/23

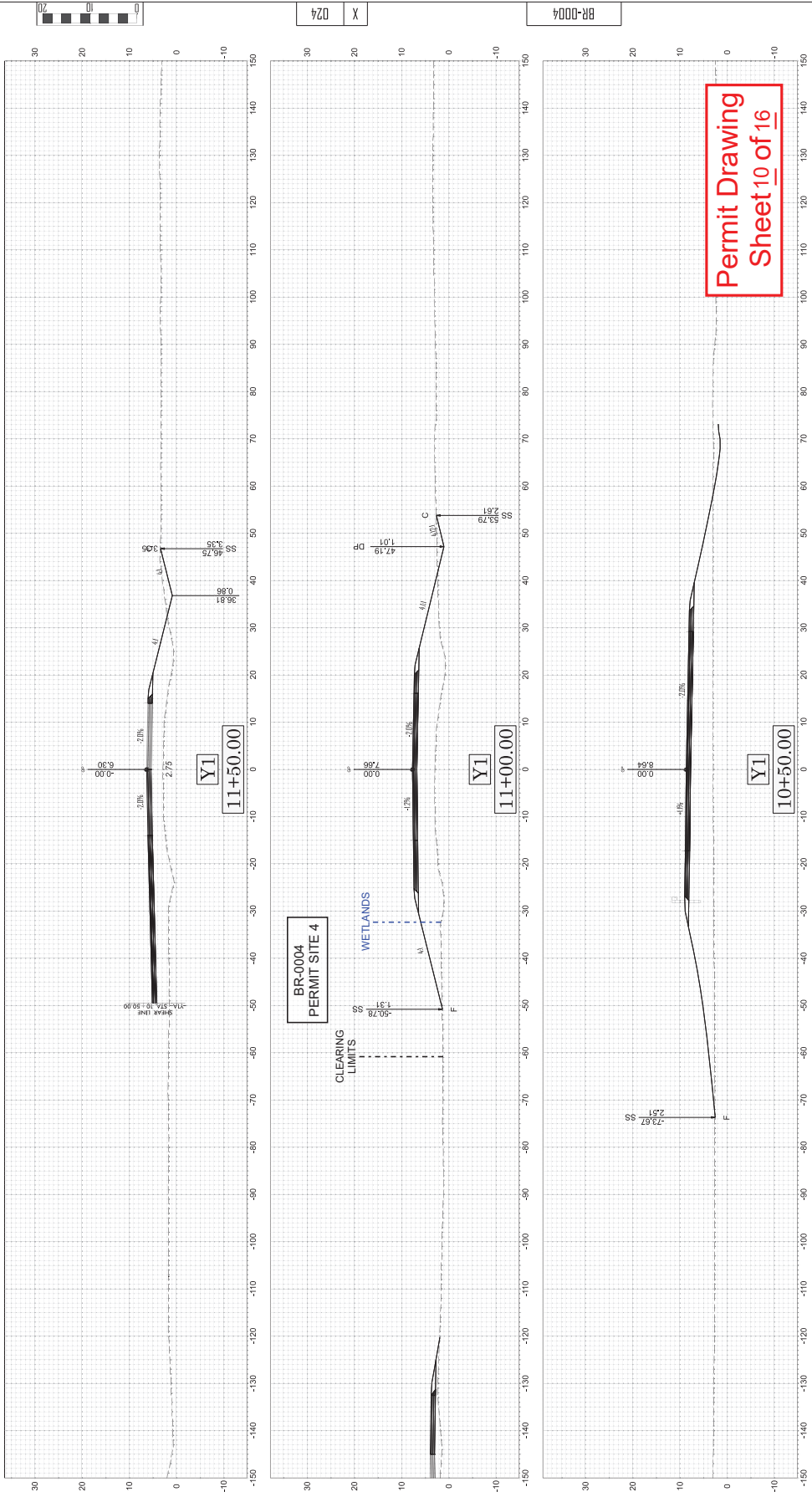

Permit Drawing
Sheet 10 of 16

BR-0004 - 12/15/2024

Submitted 1/30/2026 for Reverification

11/4/23



X 0720

BR-0004

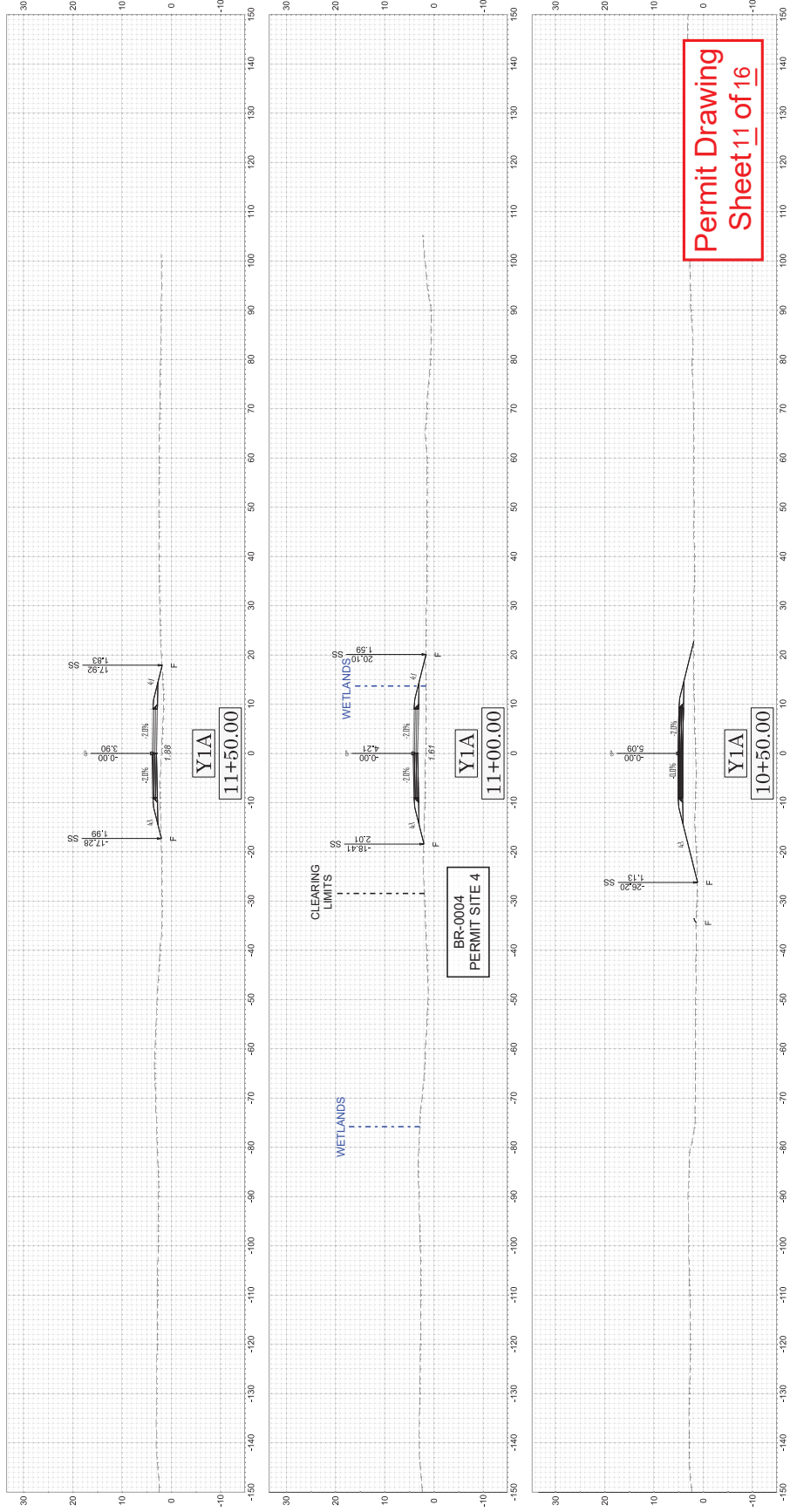

Permit Drawing
Sheet 11 of 16

IN/TRANET/BOARD - 12/16/2024

Submitted 1/30/2026 for Reverification

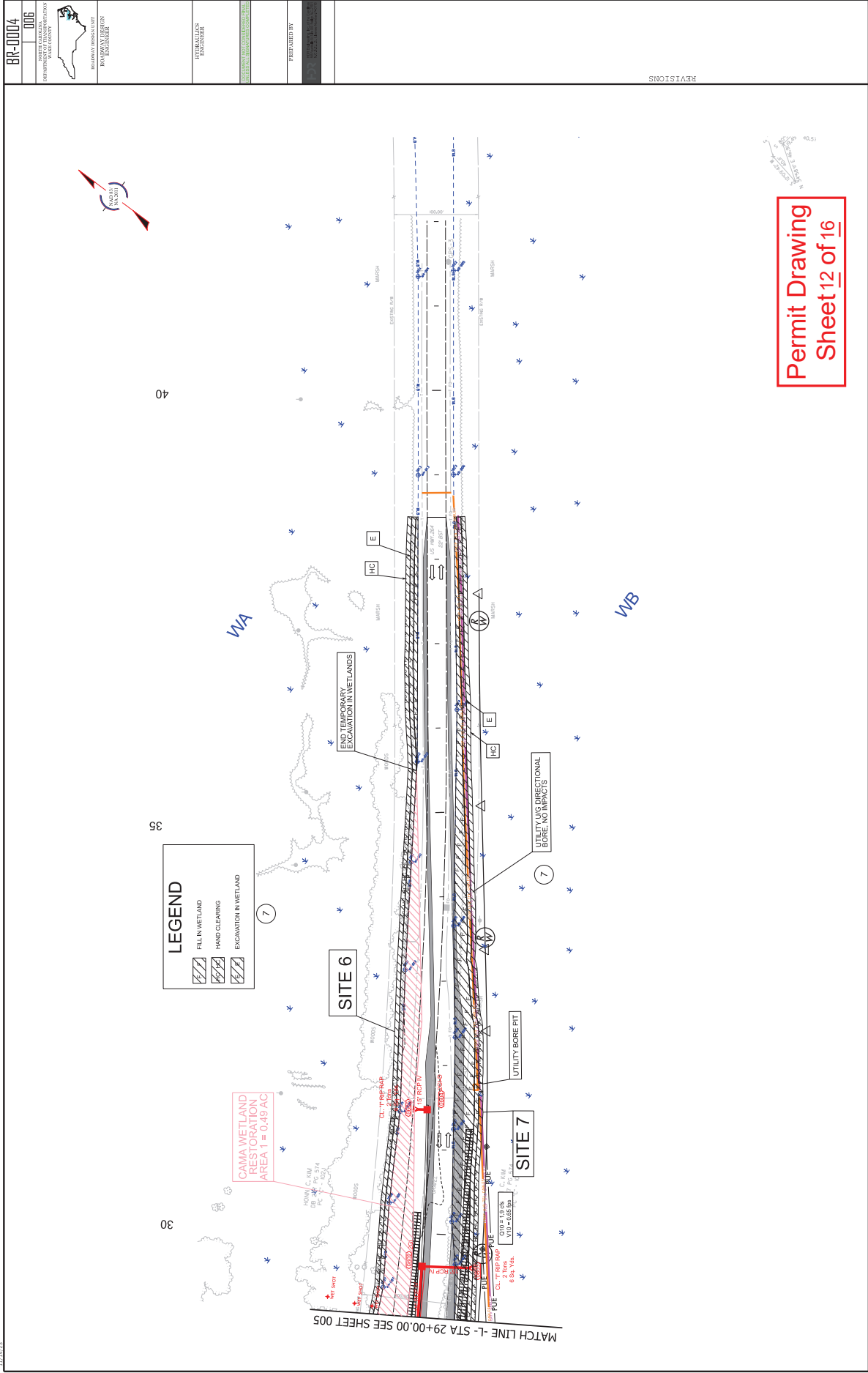

Permit Drawing Sheet 12 of 16

Submitted 1/30/2026 for Reverification

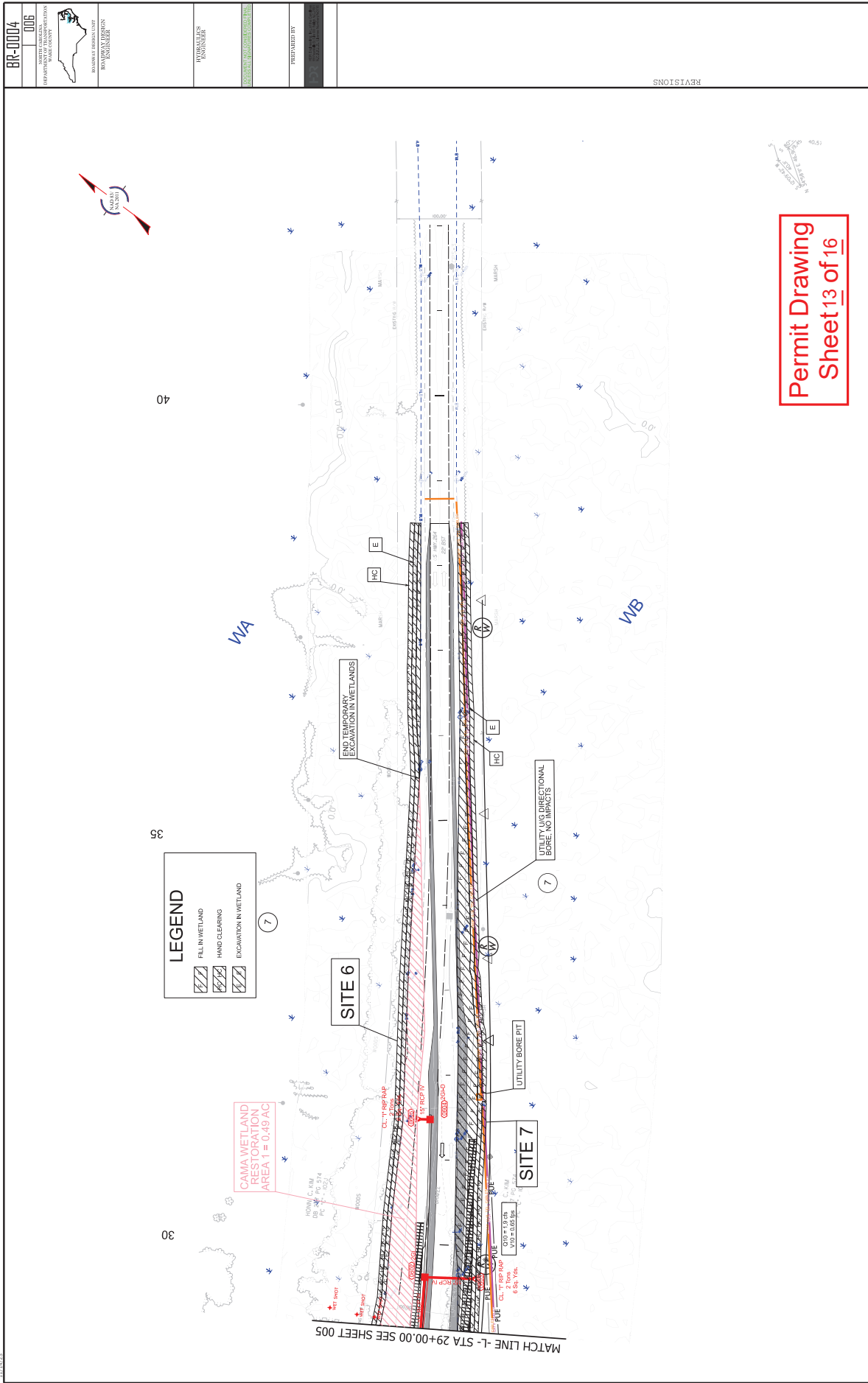

BR-0004	0006	STATE OF CALIFORNIA DEPARTMENT OF WATER RESOURCES WATER DIVISION	STATE OF CALIFORNIA DEPARTMENT OF WATER RESOURCES WATER DIVISION
		DESIGNED BY MAXIMUS DESIGN ENGINEERS	APPROVED BY [Signature]
		PREPARED BY	

Permit Drawing
Sheet 13 of 16

Submitted 1/30/2026 for Reverification

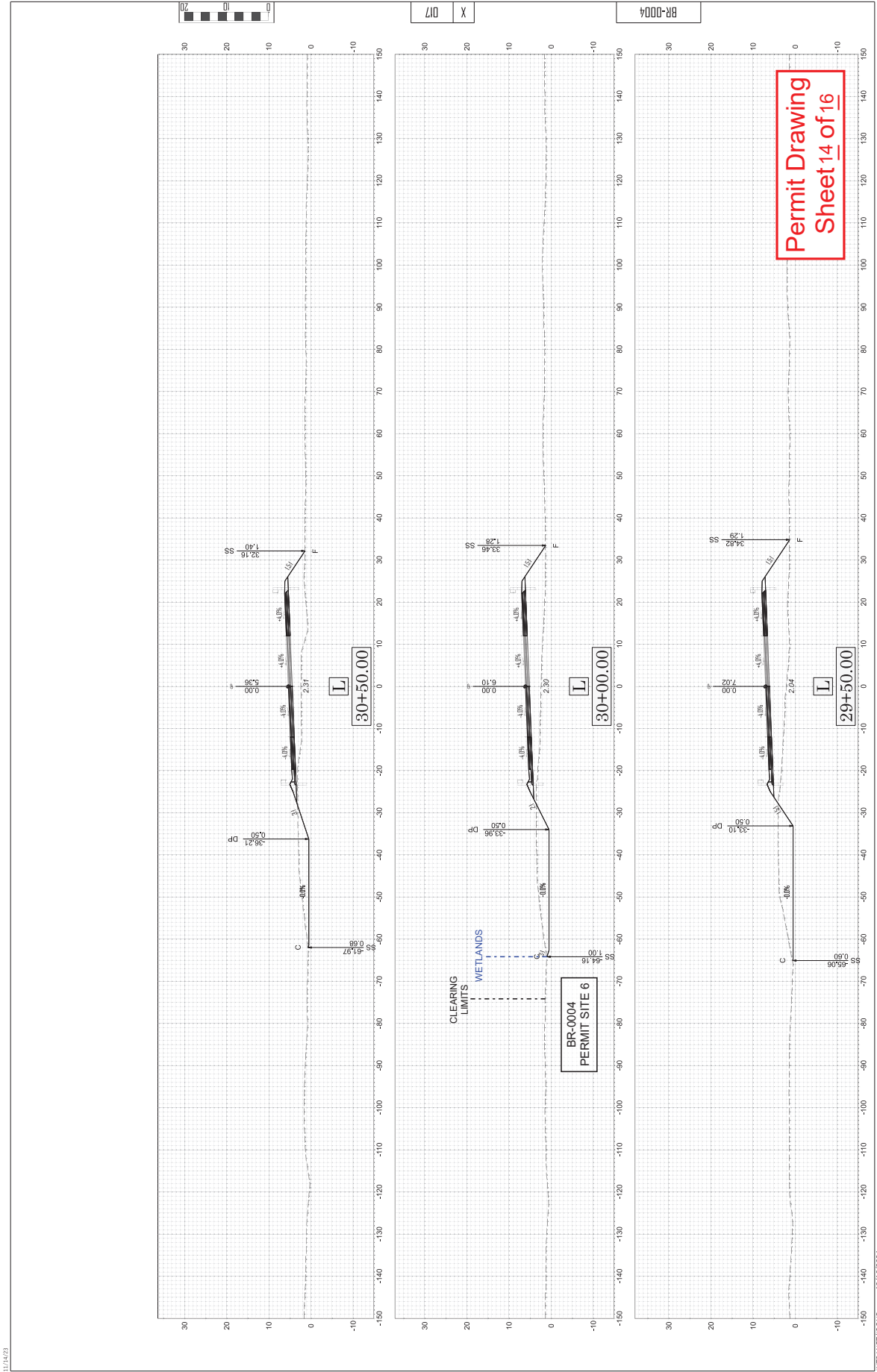

Submitted 1/31/2025

See Sheet 1A For Index of Sheets
See Sheet 1B For Conventional Symbols

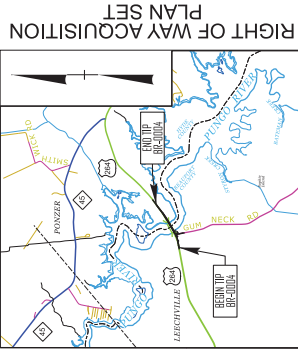

STATE PROJECT REFERENCE NO.	BR-0004
DATE	1/31/2025
STATE PROJECT NO.	67004.1.1
F.A. PROJ. NO.	N/A
DESCRIPTION	P.E.

STATE OF NORTH CAROLINA
DIVISION OF HIGHWAYS

BEAUFORT & HYDE COUNTY

LOCATION: BRIDGE NO. 66 ON US. 264 OVER PUNGO RIVER

TYPE OF WORK: GRADING, PAVING, DRAINAGE, AND STRUCTURES

BUFFER IMPACTS

BEGIN BRIDGE
-L- POT STA. 20+43.50

SITE 1

6

5

4

BEGIN TIP PROJECT
-L- STA. 11+00.00

END BRIDGE
-L- POT STA. 26+56.50

END TIP PROJECT
-L- STA. 38+50.00

**Buffer Drawing
Sheet 1 of 4**

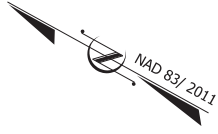

INCOMPLETE PLANS
DO NOT BE USED FOR ACQUISITION
OR CONSTRUCTION PURPOSES



HYDRAULICS ENGINEER

SIGNATURE: ROADWAY DESIGN ENGINEER

SCALE: P.E.

HR HOR Engineering, Inc. of the Carolinas
555 Fayetteville St., Suite 900 Raleigh, N.C. 27601
N.C.B.E.L.S. License Number: F-0116

PROJECT MANAGER: DOMENICA COLETTI, PE

PROJECT DESIGNER: JORDAN C. BOND, PE

RIGHT OF WAY DATE: DECEMBER 19, 2024

LETTING DATE: SEPTEMBER 16, 2025

PROJECT LENGTH

LENGTH ROADWAY TIP PROJECT BR-0004 = 0.405 MILES
LENGTH STRUCTURE TIP PROJECT BR-0004 = 0.116 MILES
TOTAL LENGTH TIP PROJECT BR-0004 = 0.521 MILES

NCDOT CONTACT: CATHERINE A. HOSSACKMEYER

DESIGN DATA

ADT 2025 = 2,763
ADT 2045 = 3,800
K = 9 %
D = 55 %
T = 17 %
V = 60 MPH
(* TTST 3% + DUAL 14%)
FUNC CLASS = ARTERIAL
REGIONAL TIER

GRAPHIC SCALES

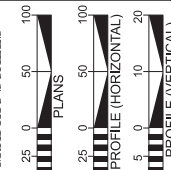

CLEARING ON THIS PROJECT SHALL BE PERFORMED TO THE LIMITS ESTABLISHED BY METHOD 11.

TIP PROJECT: BR--0004

CONTRACT:

1/31/2025

BR-0004	0005	 NORTH CAROLINA DEPARTMENT OF TRANSPORTATION DIVISION OF HIGHWAY DESIGN
		PROJECT: BRIDGE 29+00.00 SEE SHEET 006 PREPARED BY:
		APPROVED BY:
		DATE:

Submitted 1/31/2025

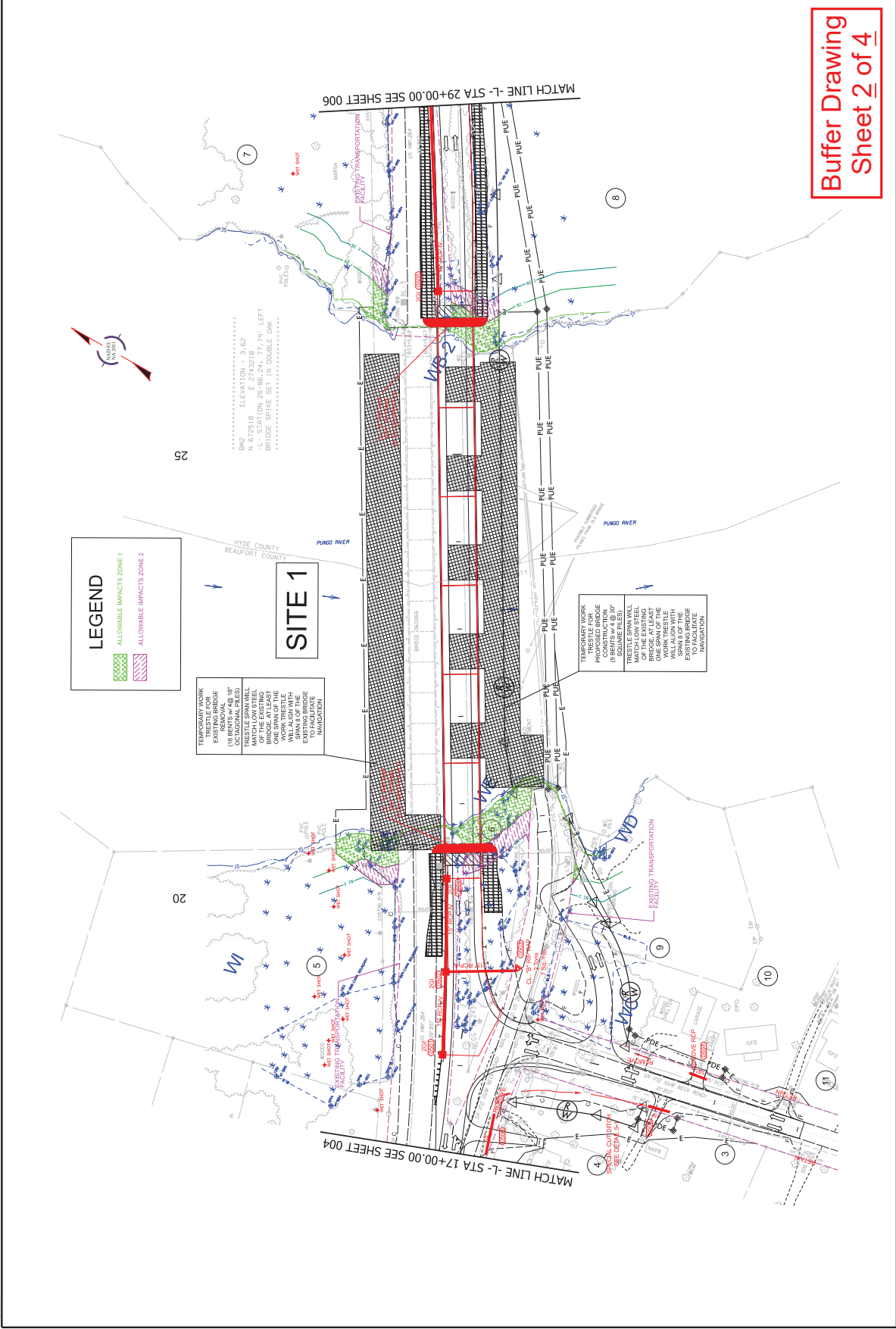

Buffer Drawing
Sheet 2 of 4

Submitted 1/30/2026 for Reverification

STATE OF NORTH CAROLINA
DIVISION OF HIGHWAYS

BEAUFORT & HYDE COUNTY

LOCATION: BRIDGE NO. 66 ON US. 264 OVER PUNGO RIVER

TYPE OF WORK: GRADING, PAVING, DRAINAGE, AND STRUCTURES

UTILITY WETLAND AND STREAM IMPACTS

PERMIT DRAWING
SHEET 1 OF 7

INCOMPLETE PLANS
DO NOT BE USED FOR CONSTRUCTION
UNLESS ALL REVISIONS ARE INCORPORATED

STATE PROJECT REFERENCE NO. BR-0004

DATE: N.C. 6/7/04

DESIGNER: I

PROJECT NO.: 67004.1.1

DATE: N/A

PROJECT TYPE: P.E.

HYDRAULICS ENGINEER

PROJECT MANAGER

DATE: SEPTEMBER 16, 2025

PROJECT MANAGER

DATE: SEPTEMBER 16, 2025

HR HOR Engineering, Inc. of the Carolinas
555 Fayetteville St., Suite 900 Raleigh, N.C. 27601
N.C.B.E.L.S. License Number: F-0116

RIGHT OF WAY DATE: DECEMBER 19, 2024

LETTING DATE: SEPTEMBER 16, 2025

PROJECT MANAGER: DOMENICA COLETTI, PE

PROJECT MANAGER: JORDAN C. BOND, PE

PROJECT MANAGER: CATHERINE A. HOSSACKMEYER

DESIGN DATA

ADT 2025 = 2,763

ADT 2045 = 3,800

K = 9 %

D = 55 %

T = 17 %

V = 60 MPH

(* TTST 3% + DUAL 14%)

FUNC CLASS = RURAL

REGIONAL TIER = ARTERIAL

GRAPHIC SCALES

PLANS: 1" = 100'

PROFILE (HORIZONTAL): 1" = 20'

PROFILE (VERTICAL): 1" = 5'

PROJECT LENGTH

LENGTH ROADWAY TIP PROJECT BR-0004 = 0.405 MILES

LENGTH STRUCTURE TIP PROJECT BR-0004 = 0.116 MILES

TOTAL LENGTH TIP PROJECT BR-0004 = 0.521 MILES

NC DOT CONTACT: CATHERINE A. HOSSACKMEYER

CLEARING ON THIS PROJECT SHALL BE PERFORMED TO THE LIMITS ESTABLISHED BY METHOD 11.

See Sheet 1A For Index of Sheets

See Sheet 1B For Conventional Symbols

See Sheet 1C For Right of Way Acquisition Plan Set

VICINITY MAP (NTS)

BRIDGE NO. 66 ON US. 264 OVER PUNGO RIVER

BEAUFORT COUNTY

HYDE COUNTY

PUNGO RIVER

TO BELHAVEN

TO SCRANTON

BEGIN BRIDGE -L- POT STA. 20+43.50

BEGIN TIP PROJECT -L- STA. 11+00.00

END BRIDGE -L- POT STA. 26+56.50

END TIP PROJECT -L- STA. 38+50.00

SITE 1

11/03/2011

TIP PROJECT: BR--0004

CONTRACT:

11/03/2011

Submitted 1/30/2026 for Reverification

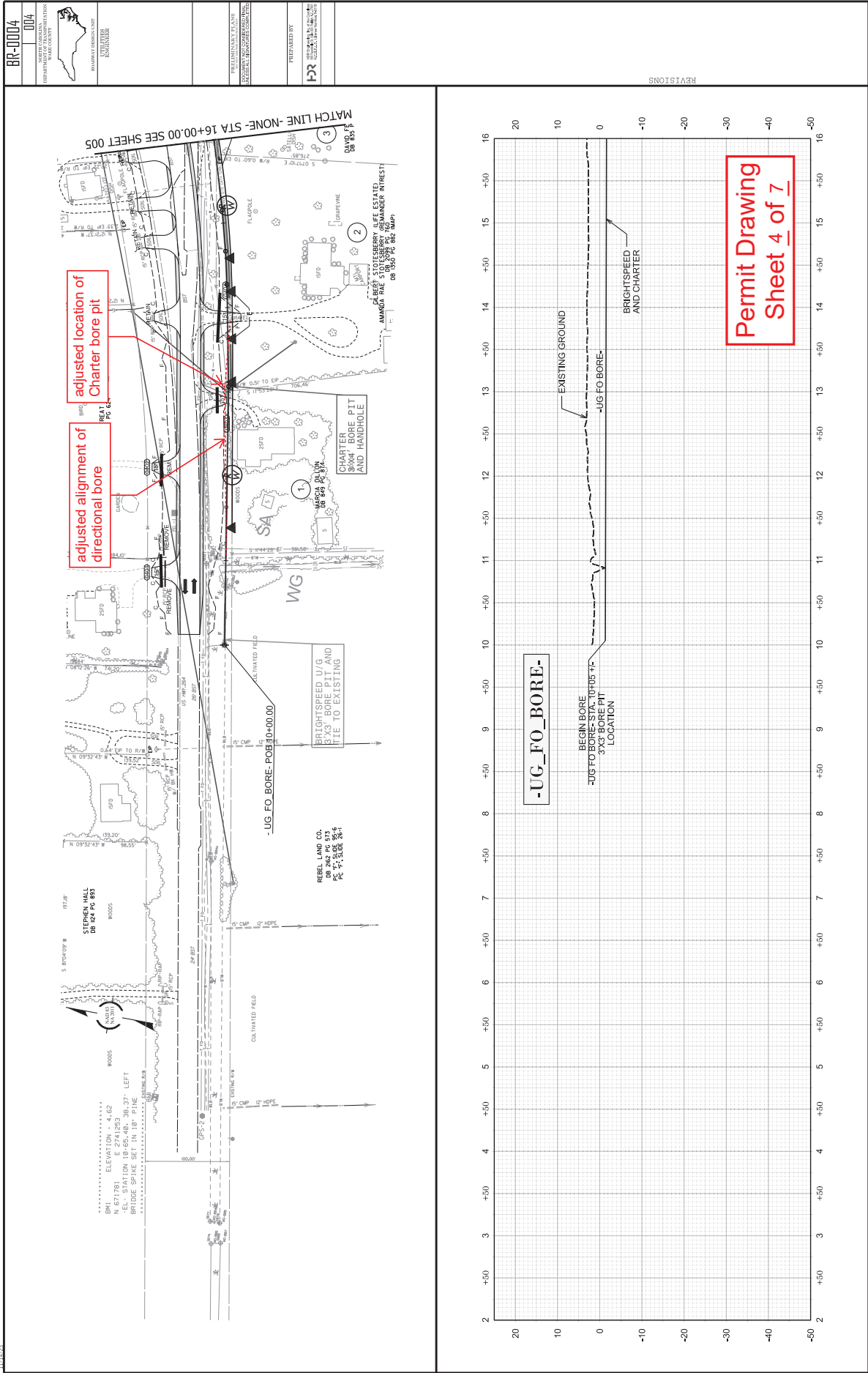

BR-0004	004
INDIANAPOLIS REGIONAL WATERWORKS DEPARTMENT OF PUBLIC UTILITIES ENGINEER	
PREPARED BY HPR	

REVISIONS

Submitted 1/30/2026 for Reverification

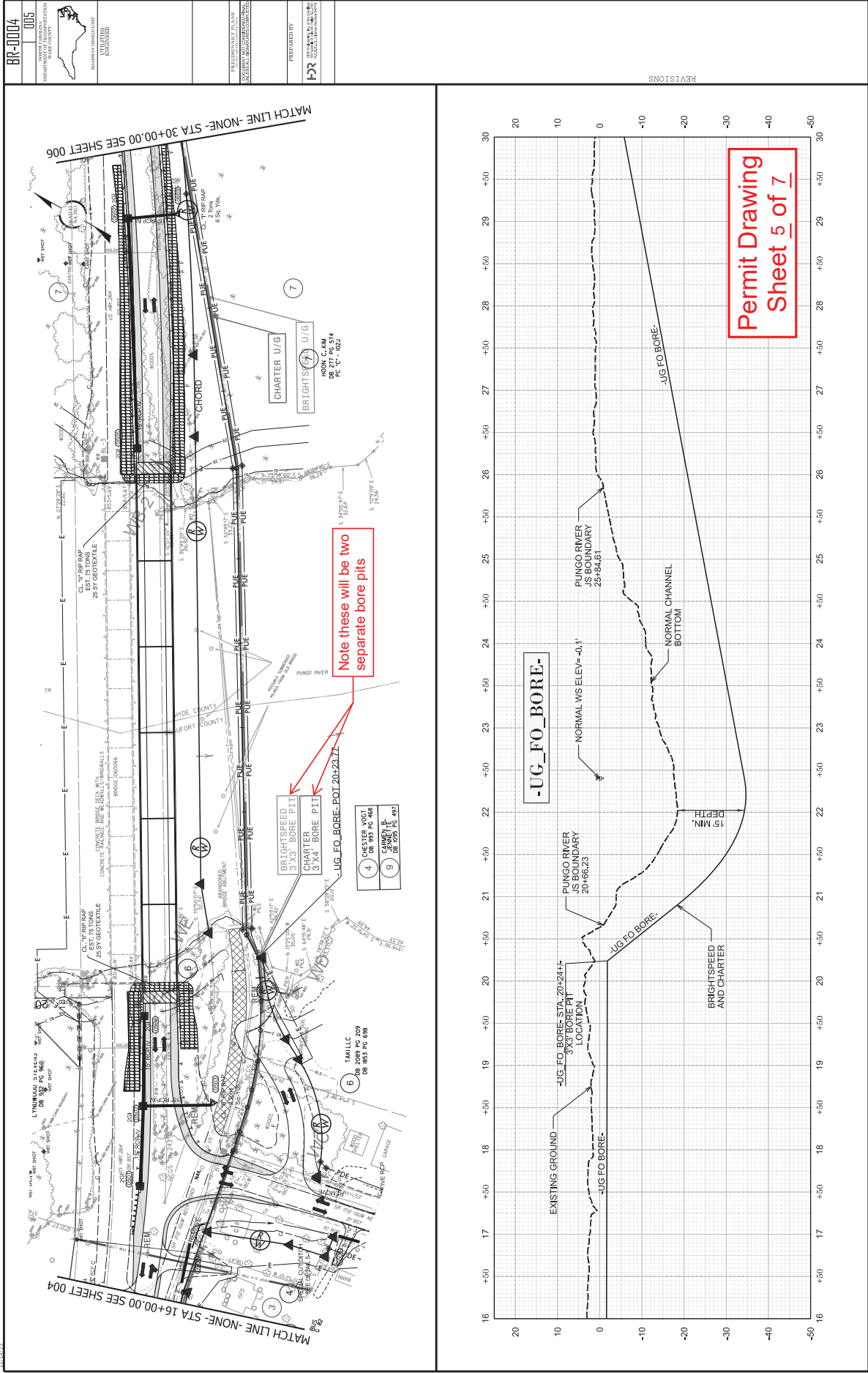

Permit Drawing
 Sheet 5 of 7

Submitted 1/30/2026 for Reverification

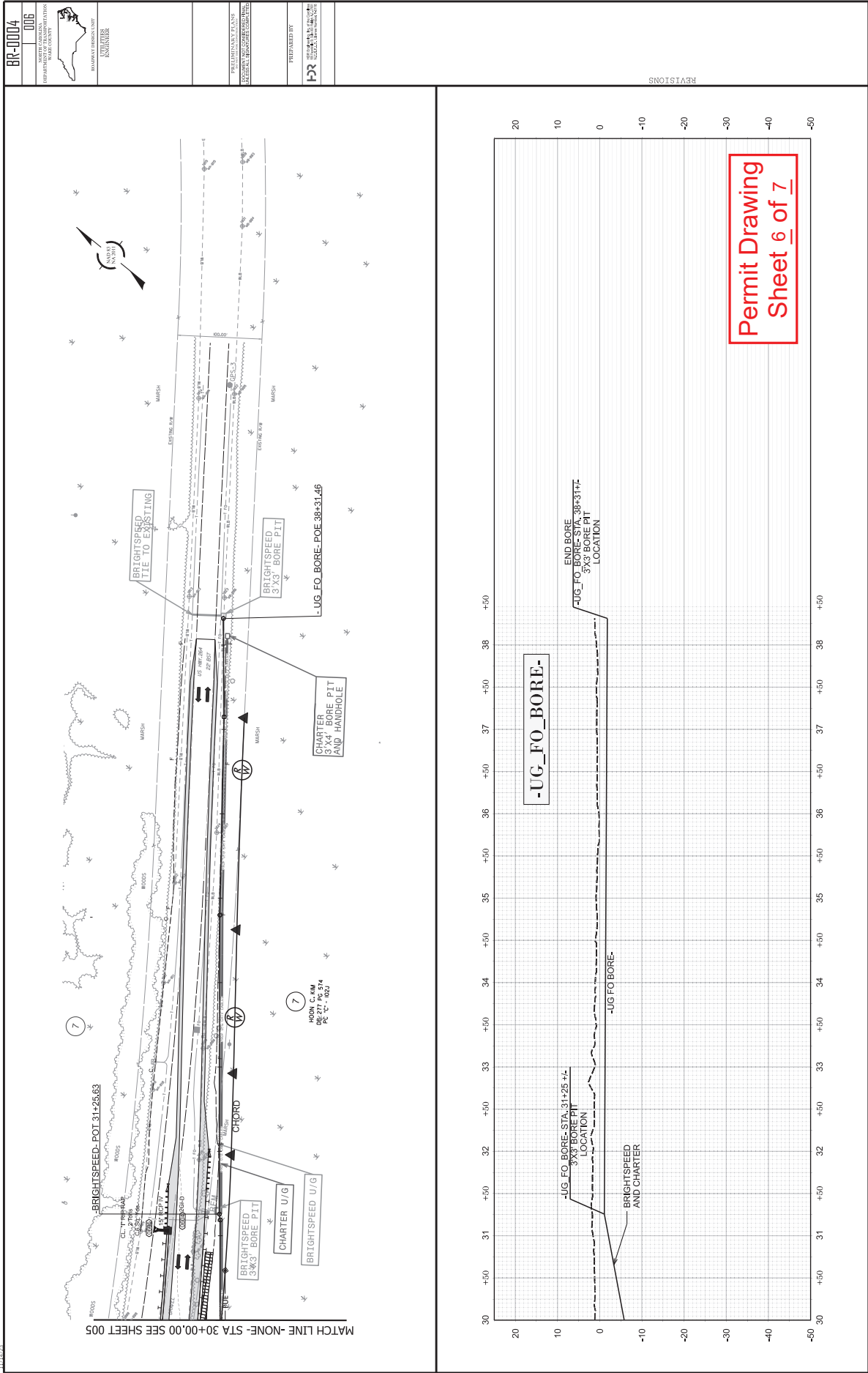

BR-0004	006
NORTH CAROLINA DEPARTMENT OF TRANSPORTATION ROAD & TRANSPORTATION ENGINEERING	
PROJECT NAME PROJECT LOCATION	
PREPARED BY DATE	

REVISIONS

Submitted 1/30/2026 for Reverification

STATE OF NORTH CAROLINA
DIVISION OF HIGHWAYS

UTILITIES PLAN SHEET SYMBOLS

UTILITY CONSTRUCTION

BR-0004
 NORTH CAROLINA
 DEPARTMENT OF TRANSPORTATION
 DIVISION OF HIGHWAYS
 UTILITY SYMBOLS
 DRAWN BY: OCS
 CHECKED BY:
 DATE:
 UTILITY ENGINEER'S SEAL
 PREPARED BY:
 IPR
 OFFICE OF THE STATE ENGINEER
 NORTH CAROLINA
 DEPARTMENT OF TRANSPORTATION
 DIVISION OF HIGHWAYS

PROPOSED WATER SYMBOLS

Water Line (Sized as Shown)	—————
1 1/4 Degree Bend	⋈
2 1/2 Degree Bend	⋈
45 Degree Bend	⋈
90 Degree Bend	⋈
Plug	⊥
Tee	⊕
Cross	⊕
Reducer	⊕
Gate Valve	⊕
Butterfly Valve	⊕
Tapping Valve	⊕
Line Stop	⊕
Line Stop with Bypass	⊕
Blow Off	⊕
Fire Hydrant	⊕
Relocate Fire Hydrant	⊕
Remove Fire Hydrant	⊕
Water Meter	⊕
Relocate Water Meter	⊕
Remove Water Meter	⊕
Water Pump Station	⊕
RPZ Backflow Preventer	⊕
DCV Backflow Preventer	⊕
Relocate RPZ Backflow Preventer	⊕
Relocate DCV Backflow Preventer	⊕

PROPOSED SEWER SYMBOLS

Gravity Sewer Line (Sized as Shown)	—————
Force Mains Sewer Line (Sized as Shown)	—————
Manhole (Sized per Note)	⊕
Sewer Pump Station	⊕

PROPOSED MISCELLANEOUS UTILITIES SYMBOLS

Power Pole	⊕
Telephone Pole	⊕
Joint Use Pole	⊕
Telephone Pedestal	⊕
Utility Line by Others (Type as Shown)	⊕
Trenchless Installation	⊕
Encasement Method	⊕
Encasement	⊕

EXISTING UTILITIES SYMBOLS

Power Pole	⊕	*Underground Power Line	—————
Telephone Pole	⊕	*Underground Telephone Cable	—————
Joint Use Pole	⊕	*Underground Telephone Conduit	—————
Utility Pole	⊕	*Underground Fiber Optics Telephone Cable	—————
Utility Pole with Base	⊕	*Underground TV Cable	—————
H-Frame Pole	⊕	*Underground Fiber Optics TV Cable	—————
Power Transmission Line Tower	⊕	*Underground Gas Pipeline	—————
Water Manhole	⊕	Aboveground Gas Pipeline	—————
Power Manhole	⊕	*Underground Water Line	—————
Telephone Manhole	⊕	Aboveground Water Line	—————
Sanitary Sewer Manhole	⊕	*Underground Gravity Sanitary Sewer Line	—————
Hand Hole for Cable	⊕	Aboveground Gravity Sanitary Sewer Line	—————
Power Transformer	⊕	*Underground SS Forced Main Line	—————
Telephone Pedestal	⊕	Underground Unknown Utility Line	—————
CATV Pedestal	⊕	SUE Test Hole	⊕
Gas Valve	⊕	Water Meter	⊕
Gas Meter	⊕	Water Valve	⊕
Located Miscellaneous Utility Object	⊕	Fire Hydrant	⊕
Abandoned According to Utility Records	⊕	Sanitary Sewer Cleanout	⊕
End of Information	⊕		

*For Existing Utilities
 Utility Line Drawn from Record
 (Type as Shown)
 Designated Utility Line
 (Type as Shown)

BR-0004	98
NORTH CAROLINA DEPARTMENT OF TRANSPORTATION ROADWAY DESIGN DIVISION	
UTILITY INSTALLATION	
DATE	
PROJECT NAME	
DRAWING NUMBER	
DESIGNED BY	
CHECKED BY	
DATE	
VALUES CONSIDERED	
PREPARED BY	
DATE	



REVISIONS

Submitted 1/30/2026 for Reverification

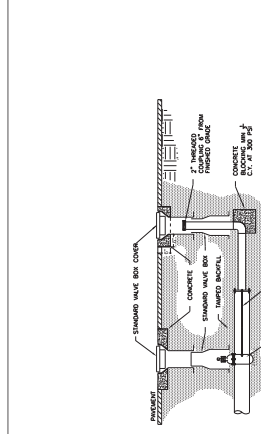

2 INCH BLOW-OFF ASSEMBLY

NOTES:
 1. ALL UNFINISHED CONCRETE SHALL BE FINISHED TO MATCH THE FINISHED SURFACE.
 2. ALL UNFINISHED CONCRETE SHALL BE FINISHED TO MATCH THE FINISHED SURFACE.
 3. ALL UNFINISHED CONCRETE SHALL BE FINISHED TO MATCH THE FINISHED SURFACE.

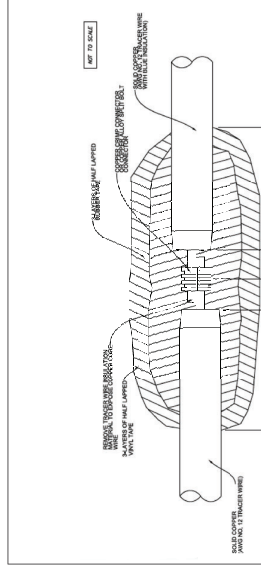

IN-LINE SPLICE

NOTES:
 1. ALL UNFINISHED CONCRETE SHALL BE FINISHED TO MATCH THE FINISHED SURFACE.
 2. ALL UNFINISHED CONCRETE SHALL BE FINISHED TO MATCH THE FINISHED SURFACE.
 3. ALL UNFINISHED CONCRETE SHALL BE FINISHED TO MATCH THE FINISHED SURFACE.

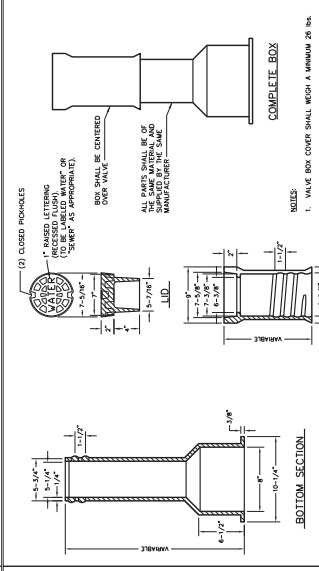

VALVE BOX INSTALLATION

NOTES:
 1. VALVE BOX COVER SHALL BEHOLD A MINIMUM 26 lbs.
 2. CAST FROM CLASS 30 GRAY IRON.
 3. ASSEMBLY SHALL BE DOMESTICALLY MADE AND MANUFACTURED IN THE U.S.A.

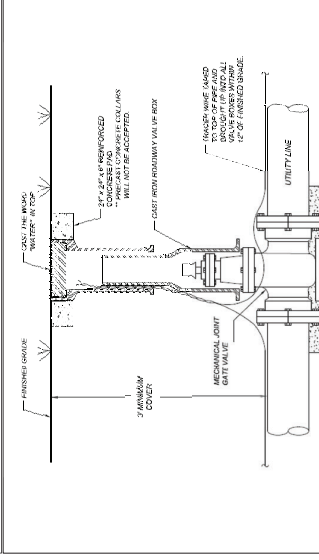

GATE VALVE DETAIL

NOTES:
 1. ALL UNFINISHED CONCRETE SHALL BE FINISHED TO MATCH THE FINISHED SURFACE.
 2. ALL UNFINISHED CONCRETE SHALL BE FINISHED TO MATCH THE FINISHED SURFACE.
 3. ALL UNFINISHED CONCRETE SHALL BE FINISHED TO MATCH THE FINISHED SURFACE.

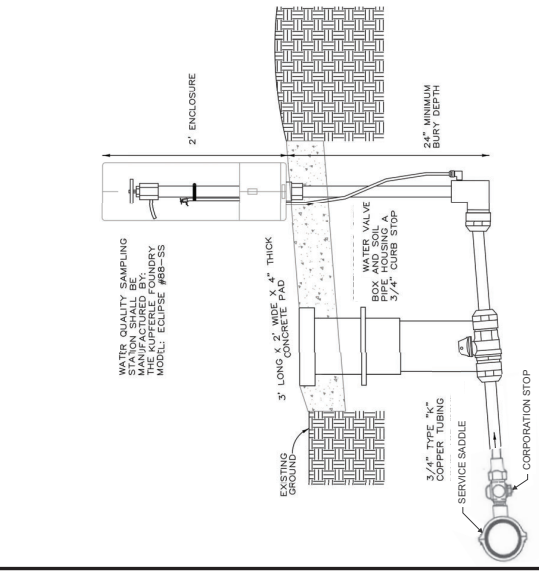

SAMPLING STATION

NOTES:
 1. ALL UNFINISHED CONCRETE SHALL BE FINISHED TO MATCH THE FINISHED SURFACE.
 2. ALL UNFINISHED CONCRETE SHALL BE FINISHED TO MATCH THE FINISHED SURFACE.
 3. ALL UNFINISHED CONCRETE SHALL BE FINISHED TO MATCH THE FINISHED SURFACE.

BR-0004	004
SOUTH COUNTY UTILITIES	
SOUTH COUNTY WATER TREATMENT PLANT	
UTILITY PROJECTS	
BR'S UTILITY CONSTRUCTION	
DRAWN BY: CDM	
CHECKED BY:	
DATE: 08/11/2020	
PROJECT NO: 20190000	
PROJECT NAME: UTILITY CONSTRUCTION	
PREPARED BY:	
DATE: 08/11/2020	



UTILITY CONSTRUCTION

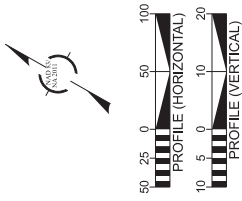

Submitted 1/30/2026 for Reverification

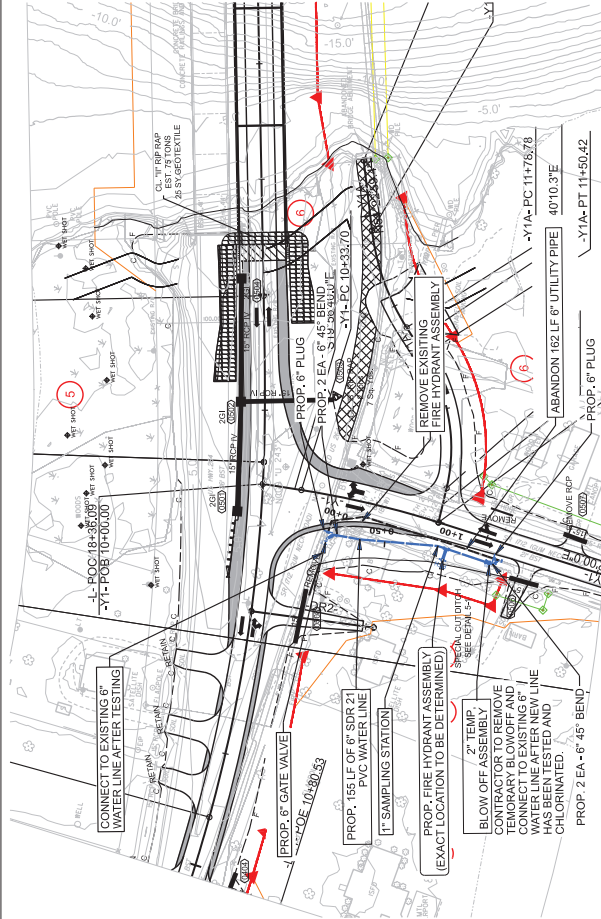

NOTE:
 1. INSTALL WATER LINE HYDRANT AND BLOW OFF.
 2. TEST THE WATER LINE.
 3. ONCE THE LINE PASSES TEST, CONNECT TO EXISTING LINE BY PASSING LINE AND TEST EXISTING LINE AT BOTH ENDS AND THEN CONNECT TO NEW WATER LINE.

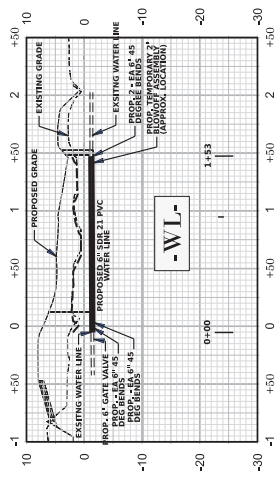

REVISIONS:

County: HYDE, BEAUFORT

Line #	Item Number	Sec #	Description	Quantity	Unit Cost	Amount
ROADWAY ITEMS						
0001	0000100000-N	800	MOBILIZATION	Lump Sum	L.S.	
0002	0000400000-N	801	CONSTRUCTION SURVEYING	Lump Sum	L.S.	
0003	0015000000-N	205	SEALING ABANDONED WELLS	1 EA		
0004	0043000000-N	226	GRADING	Lump Sum	L.S.	
0005	0050000000-E	226	SUPPLEMENTARY CLEARING & GRUBBING	1 ACR		
0006	0057000000-E	226	UNDERCUT EXCAVATION	2,500 CY		
0007	0127000000-N	235	EMBANKMENT SETTLEMENT GAUGES	3 EA		
0008	0134000000-E	240	DRAINAGE DITCH EXCAVATION	850 CY		
0009	0196000000-E	270	GEOTEXTILE FOR SOIL STABILIZATION	1,000 SY		
0010	0199000000-E	SP	TEMPORARY SHORING	510 SF		
0011	0223000000-E	275	ROCK PLATING	1,685 SY		
0012	0234000000-E	SP	GENERIC GRADING ITEM SELECT GRANULAR MATERIAL, MODIFIED CLASS III	3,550 CY		
0013	0248000000-N	SP	GENERIC GRADING ITEM TYPE 1 BRIDGE APPROACH FILL, STATION 23+50.00 -L-	Lump Sum	L.S.	
0014	0318000000-E	300	FOUNDATION CONDITIONING MATERIAL, MINOR STRUCTURES	110 TON		
0015	0321000000-E	300	FOUNDATION CONDITIONING GEOTEXTILE	340 SY		
0016	0335200000-E	305	15" DRAINAGE PIPE	388 LF		
0017	0448200000-E	310	15" RC PIPE CULVERTS, CLASS IV	636 LF		

County: HYDE, BEAUFORT

Line #	Item Number	Sec #	Description	Quantity	Unit Cost	Amount
0018	0995000000-E	340	PIPE REMOVAL	250 LF		
0019	1099500000-E	505	SHALLOW UNDERCUT	250 CY		
0020	1099700000-E	505	CLASS IV SUBGRADE STABILIZATION	500 TON		
0021	1111000000-E	SP	CLASS IV AGGREGATE STABILIZATION	500 TON		
0022	1112000000-E	505	GEOTEXTILE FOR SUBGRADE STABILIZATION	750 SY		
0023	1121000000-E	520	AGGREGATE BASE COURSE	240 TON		
0024	1330000000-E	607	INCIDENTAL MILLING	580 SY		
0025	1491000000-E	610	ASPHALT CONC BASE COURSE, TYPE B25.0C	2,580 TON		
0026	1503000000-E	610	ASPHALT CONC INTERMEDIATE COURSE, TYPE I19.0C	1,870 TON		
0027	1519000000-E	610	ASPHALT CONC SURFACE COURSE, TYPE S9.5B	50 TON		
0028	1523000000-E	610	ASPHALT CONC SURFACE COURSE, TYPE S9.5C	1,890 TON		
0029	1575000000-E	620	ASPHALT BINDER FOR PLANT MIX	325 TON		
0030	2022000000-E	815	SUBDRAIN EXCAVATION	45 CY		
0031	2026000000-E	815	GEOTEXTILE FOR SUBSURFACE DRAINS	200 SY		
0032	2036000000-E	815	SUBDRAIN COARSE AGGREGATE	34 CY		
0033	2044000000-E	815	6" PERFORATED SUBDRAIN PIPE	200 LF		
0034	2070000000-N	815	SUBDRAIN PIPE OUTLET	1 EA		

County: HYDE, BEAUFORT

Line #	Item Number	Sec #	Description	Quantity	Unit Cost	Amount
0035	2077000000-E	815	6" OUTLET PIPE	6 LF		
0036	2253000000-E	840	PIPE COLLARS	0.399 CY		
0037	2286000000-N	840	MASONRY DRAINAGE STRUCTURES	6 EA		
0038	2308000000-E	840	MASONRY DRAINAGE STRUCTURES	1 LF		
0039	2364200000-N	840	FRAME WITH TWO GRATES, STD 840.20	6 EA		
0040	2556000000-E	846	SHOULDER BERM GUTTER	710 LF		
0041	3030000000-E	862	STEEL BEAM GUARDRAIL	1,375 LF		
0042	3045000000-E	862	STEEL BEAM GUARDRAIL, SHOP CURVED	50 LF		
0043	3145000000-E	862	EXTRA LENGTH GUARDRAIL POST (***) STEEL) (8')	170 EA		
0044	3150000000-N	862	ADDITIONAL GUARDRAIL POSTS	10 EA		
0045	3195000000-N	862	GUARDRAIL END UNITS, TYPE AT-1	1 EA		
0046	3215000000-N	862	GUARDRAIL ANCHOR UNITS, TYPE III	4 EA		
0047	3287000000-N	862	GUARDRAIL END UNITS, TYPE TL-3	3 EA		
0048	3380000000-E	862	TEMPORARY STEEL BEAM GUARDRAIL	425 LF		
0049	3387000000-N	862	TEMPORARY GUARDRAIL ANCHOR UNITS, TYPE ***** (III, MODIFIED)	2 EA		
0050	3389150000-N	862	TEMPORARY GUARDRAIL END UNITS, TYPE ***** (TL-3)	3 EA		
0051	3389160000-N	862	TEMPORARY ADDITIONAL GUARDRAIL POSTS	5 EA		

County: HYDE, BEAUFORT

Line #	Item Number	Sec #	Description	Quantity	Unit Cost	Amount
0052	3628000000-E	876	RIP RAP, CLASS I	4 TON		
0053	3649000000-E	876	RIP RAP, CLASS B	2 TON		
0054	3656000000-E	876	GEOTEXTILE FOR DRAINAGE	475 SY		
0055	4072000000-E	903	SUPPORTS, 3-LB STEEL U-CHANNEL	233 LF		
0056	4082000000-E	903	SUPPORTS, WOOD	88 LF		
0057	4096000000-N	904	SIGN ERECTION, TYPE D	4 EA		
0058	4102000000-N	904	SIGN ERECTION, TYPE E	6 EA		
0059	4110000000-N	904	SIGN ERECTION, TYPE *** (GROUND MOUNTED) (B)	4 EA		
0060	4116100000-N	904	SIGN ERECTION, RELOCATE TYPE **** (GROUND MOUNTED) (D)	1 EA		
0061	4158000000-N	907	DISPOSAL OF SIGN SYSTEM, WOOD	14 EA		
0062	4400000000-E	1110	WORK ZONE SIGNS (STATIONARY)	120 SF		
0063	4405000000-E	1110	WORK ZONE SIGNS (PORTABLE)	96 SF		
0064	4410000000-E	1110	WORK ZONE SIGNS (BARRICADE MOUNTED)	82 SF		
0065	4430000000-N	1130	DRUMS	107 EA		
0066	4435000000-N	1135	CONES	43 EA		
0067	4445000000-E	1145	BARRICADES (TYPE III)	168 LF		
0068	4455000000-N	1150	FLAGGER	58 DAY		

County: HYDE, BEAUFORT

Line #	Item Number	Sec #	Description	Quantity	Unit Cost	Amount
0069	4465000000-N	1160	TEMPORARY CRASH CUSHIONS	2 EA		
0070	4480000000-N	1165	TMA	2 EA		
0071	4485000000-E	1170	PORTABLE CONCRETE BARRIER	2,020 LF		
0072	4510000000-N	1190	LAW ENFORCEMENT	32 HR		
0073	4650000000-N	1251	TEMPORARY RAISED PAVEMENT MARKERS	61 EA		
0074	4685000000-E	1205	THERMOPLASTIC PAVEMENT MARKING LINES (4", 90 MILS)	9,706 LF		
0075	4709000000-E	1205	THERMOPLASTIC PAVEMENT MARKING LINES (24", 90 MILS)	53 LF		
0076	4770000000-E	1205	COLD APPLIED PLASTIC PAVEMENT MARKING LINES, TYPE ** (4") (IV)	2,564 LF		
0077	4810000000-E	1205	PAINT PAVEMENT MARKING LINES (4")	13,859 LF		
0078	4835000000-E	1205	PAINT PAVEMENT MARKING LINES (24")	93 LF		
0079	4846000000-E	1205	POLYUREA PAVEMENT MARKING LINES (***, *** MILS) (4", 20 MILS)	2,564 LF		
0080	4850000000-E	1205	REMOVAL OF PAVEMENT MARKING LINES (4")	5,964 LF		
0081	4895000000-N	SP	GENERIC PAVEMENT MARKING ITEM POLYCARBONATE H-SHAPED MARKERS	26 EA		
0082	4900000000-N	1251	PERMANENT RAISED PAVEMENT MARKERS	8 EA		
0083	5325600000-E	1510	6" WATER LINE	155 LF		
0084	5329000000-E	1510	DUCTILE IRON WATER PIPE FITTINGS	350 LB		
0085	5540000000-E	1515	6" VALVE	2 EA		

County: HYDE, BEAUFORT

Line #	Item Number	Sec #	Description	Quantity	Unit Cost	Amount
0086	5606000000-E	1515	2" BLOW OFF	1 EA		
0087	5666000000-N	1515	FIRE HYDRANT	1 EA		
0088	5673000000-E	1515	FIRE HYDRANT LEG	8 LF		
0089	5800000000-E	1530	ABANDON 6" UTILITY PIPE	162 LF		
0090	5815500000-N	1530	REMOVE FIRE HYDRANT	1 EA		
0091	5882000000-N	SP	GENERIC UTILITY ITEM 1" SAMPLING STATION	1 EA		
0092	6000000000-E	1605	TEMPORARY SILT FENCE	9,775 LF		
0093	6006000000-E	1610	STONE FOR EROSION CONTROL, CLASS A	165 TON		
0094	6009000000-E	1610	STONE FOR EROSION CONTROL, CLASS B	655 TON		
0095	6012000000-E	1610	SEDIMENT CONTROL STONE	350 TON		
0096	6015000000-E	1615	TEMPORARY MULCHING	4 ACR		
0097	6018000000-E	1620	SEED FOR TEMPORARY SEEDING	300 LB		
0098	6021000000-E	1620	FERTILIZER FOR TEMPORARY SEEDING	1.5 TON		
0099	6024000000-E	1622	TEMPORARY SLOPE DRAINS	605 LF		
0100	6029000000-E	SP	SAFETY FENCE	5,060 LF		
0101	6030000000-E	1630	SILT EXCAVATION	920 CY		
0102	6036000000-E	1631	MATTING FOR EROSION CONTROL	7,910 SY		

County: HYDE, BEAUFORT

Line #	Item Number	Sec #	Description	Quantity	Unit Cost	Amount
0103	6037000000-E	1629	COIR FIBER MAT	100 SY		
0104	6042000000-E	1632	1/4" HARDWARE CLOTH	810 LF		
0105	6048000000-E	SP	FLOATING TURBIDITY CURTAIN	5,950 SY		
0106	6071002000-E	1642	FLOCCULANT	320 LB		
0107	6071012000-E	1642	COIR FIBER WATTLE	65 LF		
0108	6071030000-E	1640	COIR FIBER BAFFLE	35 LF		
0109	6084000000-E	1660	SEEDING & MULCHING	6 ACR		
0110	6087000000-E	1660	MOWING	3 ACR		
0111	6090000000-E	1661	SEED FOR REPAIR SEEDING	50 LB		
0112	6093000000-E	1661	FERTILIZER FOR REPAIR SEEDING	0.25 TON		
0113	6096000000-E	1662	SEED FOR SUPPLEMENTAL SEEDING	100 LB		
0114	6108000000-E	1665	FERTILIZER TOPDRESSING	3 TON		
0115	6114500000-N	1667	SPECIALIZED HAND MOWING	10 MHR		
0116	6114800000-N	SP	MANUAL LITTER REMOVAL	2 MHR		
0117	6114900000-E	SP	LITTER DISPOSAL	1 TON		
0118	6117000000-N	1675	RESPONSE FOR EROSION CONTROL	25 EA		
0119	6117500000-N	SP	CONCRETE WASHOUT STRUCTURE	4 EA		

County: HYDE, BEAUFORT

Line #	Item Number	Sec #	Description	Quantity	Unit Cost	Amount
0120	6123000000-E	1670	REFORESTATION	0.1 ACR		
0121	6129000000-E	1670	WETLAND REFORESTATION	1 ACR		
0122	6132000000-N	SP	GENERIC EROSION CONTROL ITEM PREFABRICATED CONCRETE WASHOUT	6 EA		
0123	6135000000-E	SP	GENERIC EROSION CONTROL ITEM DISKING	1 ACR		
0124	6135000000-E	SP	GENERIC EROSION CONTROL ITEM RIPPING	1 ACR		
0125	6135000000-E	SP	GENERIC EROSION CONTROL ITEM WETLAND GRASS PLANTING	1 ACR		
STRUCTURE ITEMS						
0126	8017000000-N	SP	CONSTRUCTION, MAINTENANCE, & REMOVAL OF TEMP ACCESS AT STA ***** (23+50.00 -L-)	Lump Sum	L.S.	
0127	8035000000-N	402	REMOVAL OF EXISTING STRUCTURE AT STATION ***** (23+50.00 -L-)	Lump Sum	L.S.	
0128	8065000000-N	SP	ASBESTOS ASSESSMENT	Lump Sum	L.S.	
0129	8121000000-N	412	UNCLASSIFIED STRUCTURE EXCAVATION AT STATION ***** (23+50.00 -L-)	Lump Sum	L.S.	
0130	8147000000-E	420	REINFORCED CONCRETE DECK SLAB	25,992 SF		
0131	8161000000-E	420	GROOVING BRIDGE FLOORS	23,612 SF		
0132	8175000000-E	420	CLASS AA CONCRETE (BRIDGE)	299.7 CY		
0133	8210000000-N	422	BRIDGE APPROACH SLABS, STATION ***** (23+50.00 -L-)	Lump Sum	L.S.	
0134	8224000000-E	425	EPOXY COATED REINFORCING STEEL (BRIDGE)	38,119 LB		

County: HYDE, BEAUFORT

Line #	Item Number	Sec #	Description	Quantity	Unit Cost	Amount
0135	8265000000-E	430	54" PRESTRESSED CONCRETE GIRDERS	3,042.5 LF		
0136	8328000000-E	450	PILE DRIVING EQUIPMENT SETUP FOR *** PRESTRESSED CONCRETE PILES (30")	25 EA		
0137	8328200000-E	450	PILE DRIVING EQUIPMENT SETUP FOR *** STEEL PILES (HP 12 X 53)	22 EA		
0138	8353000000-E	450	30" PRESTRESSED CONCRETE PILES	2,575 LF		
0139	8364000000-E	450	HP 12 X 53 STEEL PILES	2,155 LF		
0140	8393000000-N	450	PILE REDRIVES	27 EA		
0141	8394000000-N	450	DYNAMIC PILE TESTING	4 EA		
0142	8475000000-E	460	TWO BAR METAL RAIL	1,205.7 LF		
0143	8517000000-E	460	1'-*** X ***** CONCRETE PARAPET (1'-2" X 2'-6")	1,220.7 LF		
0144	8608000000-E	876	RIP RAP CLASS II (2'-0" THICK)	160 TON		
0145	8622000000-E	876	GEOTEXTILE FOR DRAINAGE	180 SY		
0146	8657000000-N	430	ELASTOMERIC BEARINGS	Lump Sum	L.S.	
0147	8860000000-N	SP	GENERIC STRUCTURE ITEM STRIP SEAL EXPANSION JOINTS	Lump Sum	L.S.	

1459/Apr13/Q195646.849/D655043754000/E147

Total Amount Of Bid For Entire Project :