

LEGEND

- CRYSTAL/RED PAVEMENT MARKER
- YELLOW/YELLOW PAVEMENT MARKER
- DIRECTION OF TRAFFIC FLOW

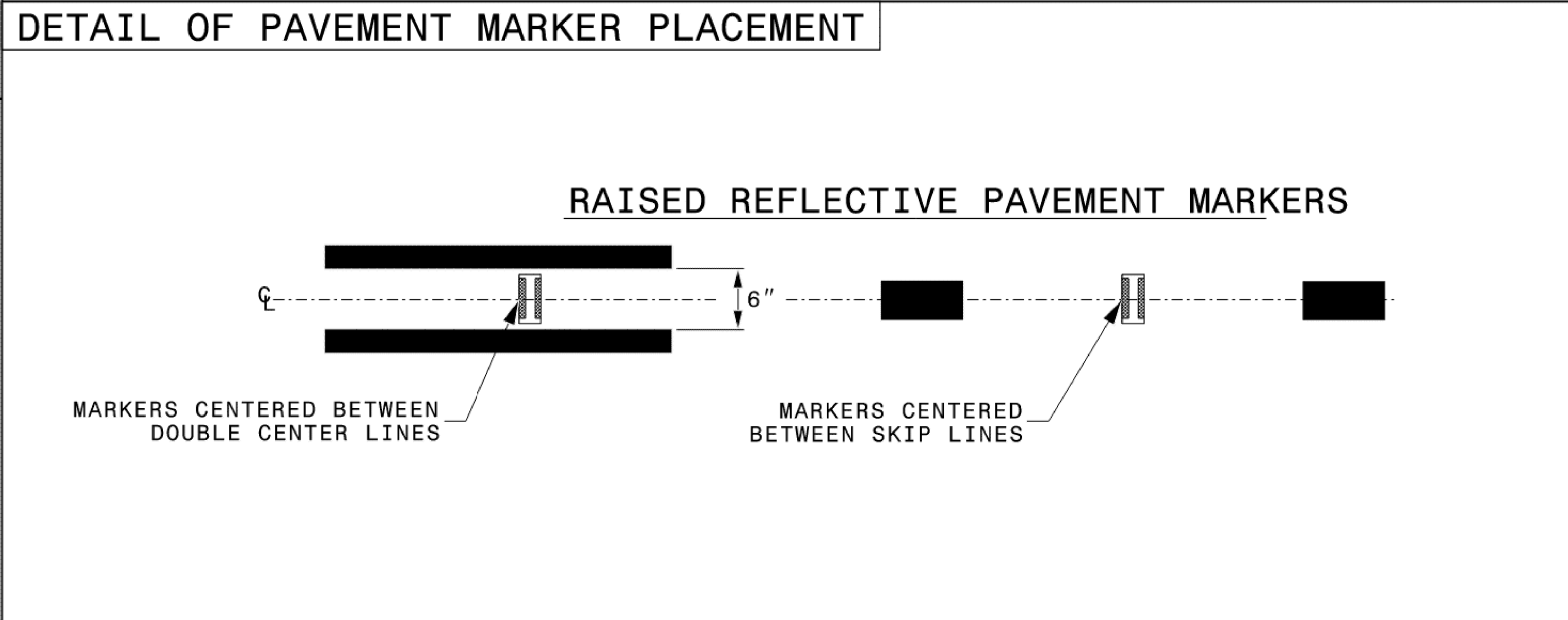
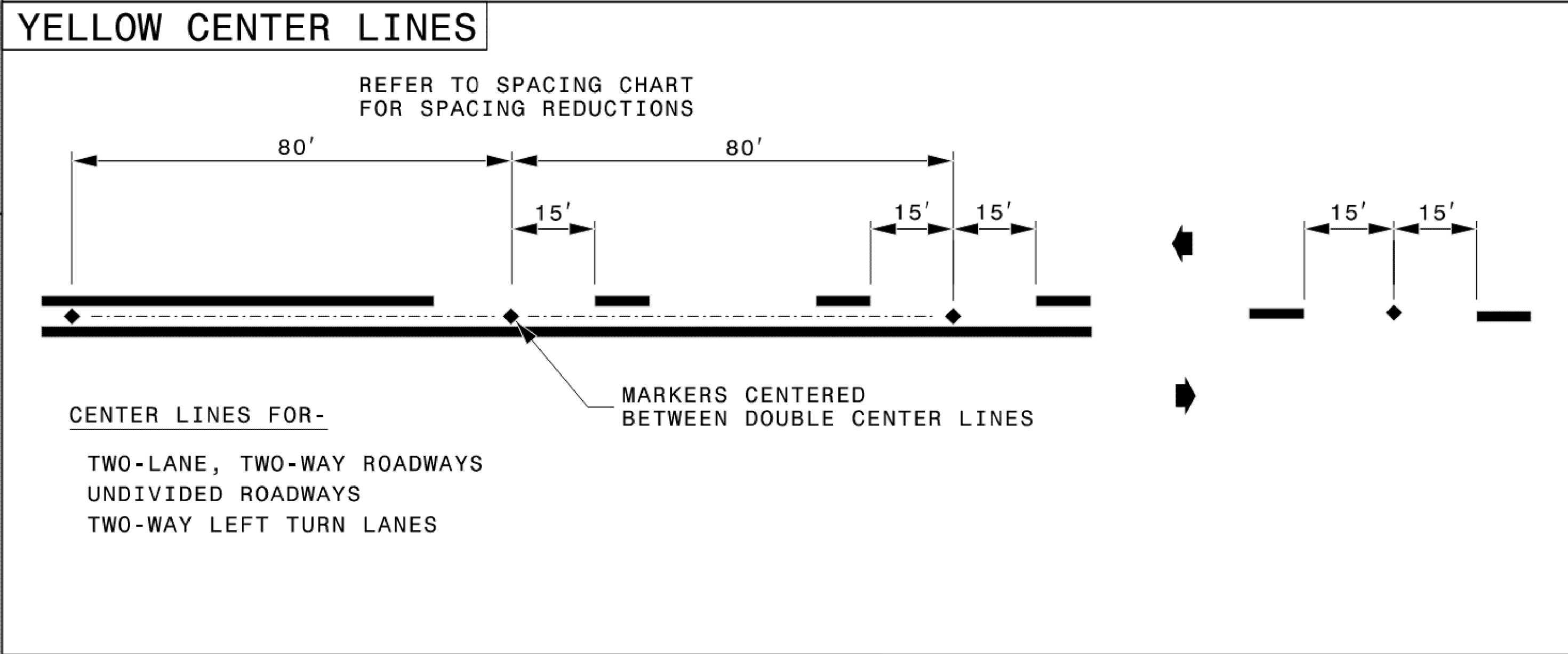
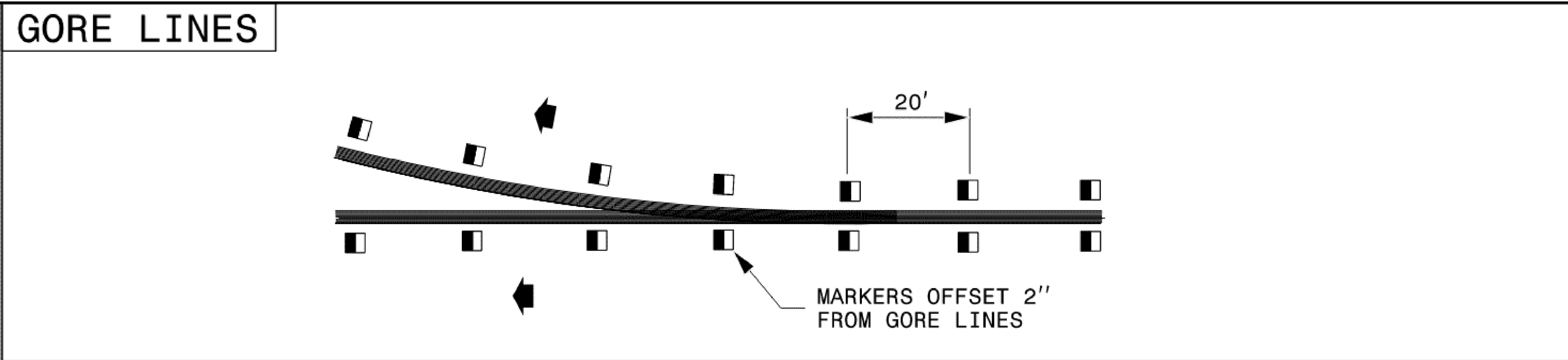

STATE OF
NORTH CAROLINA
DEPT. OF TRANSPORTATION
DIVISION OF HIGHWAYS
RALEIGH, N.C.

ROADWAY DETAIL DRAWING FOR
RAISED PAVEMENT MARKERS
INSTALLATION SPACING

SHEET 2 OF 3
1250D01



CONTRACTS STANDARDS AND DEVELOPMENT UNIT
Office 919-707-8950 FAX 919-250-4119

SEE TITLE BLOCK

ORIGINAL BY: M.V. SPRINGER DATE: 2-15-24
 MODIFIED BY: DATE:
 CHECKED BY: DATE:
 FILE SPEC.:

PAVEMENT MARKING SCHEDULE

THERMOPLASTIC LINES

- T1 WHITE EDGELINE (4", 90 MIL)
- T10 YELLOW EDGELINE (4", 90 MIL)
- T13 YELLOW DOUBLE CENTER (4", 90 MIL)
- T20 WHITE EDGELINE (6", 90 MIL)
- T21 WHITE SOLID LANE LINE (6", 90 MIL)
- T22 10FT. WHITE SKIP (6", 90 MIL)
- T23 3FT.-9FT./SP WHITE MINISKIP (6", 90 MIL)
- T24 2 FT.-6FT./SP WHITE MINISKIP (6", 90 MIL)
- T30 YELLOW EDGELINE (6", 90 MIL)
- T34 2 FT.-6FT./SP YELLOW MINISKIP (6", 90 MIL)
- T50 WHITE GORELINE (12", 90 MIL)
- T51 WHITE DIAGONAL (12", 90 MIL)
- T52 YELLOW DIAGONAL (12", 90 MIL)
- T61 WHITE STOPBAR (24", 90 MIL)
- T103 24" YIELD LINE TRIANGLE (90 MIL)

THERMOPLASTIC SYMBOLS

- T70 LEFT TURN ARROW (90 MIL)
- T71 RIGHT TURN ARROW (90 MIL)
- T77 U-TURN ARROW (90 MIL)

SNOWPLOWABLE
POLYCARBONATE H-SHAPED MARKERS

MF CRYSTAL & RED

TIP NO. HS-2401P	SHEET NO. PMP-2
<small>DocuSigned by:</small> APPROVED: _____ <small>098183F28E5741E...</small>	
DATE: 2/25/2026	
SEAL 	
DOCUMENT NOT CONSIDERED FINAL UNLESS ALL SIGNATURES COMPLETED	

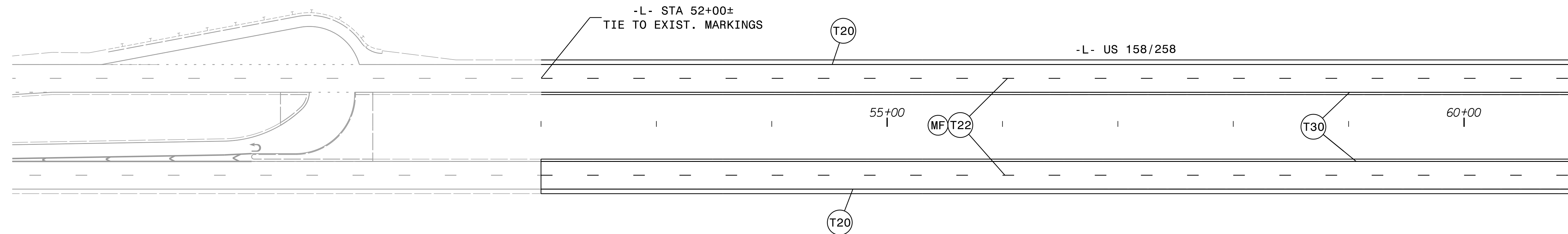

MATCHLINE - L - STA. 61+00 SEE PMP - 3

2/13/2026
HS-2401-PMP_PSH02.dgn
User: ds

RK&K
 P: (919) 878-9560
 8601 Six Forks Road, Forum 1, Suite 700
 Raleigh, North Carolina 27615-3960
 NC License No. F-0112

Engineers | Construction Managers | Planners | Scientists
 www.rkk.com

Responsive People | Creative Solutions

PAVEMENT MARKING DETAIL

PAVEMENT MARKING SCHEDULE

THERMOPLASTIC LINES

- T1 WHITE EDGELINE (4", 90 MIL)
- T10 YELLOW EDGELINE (4", 90 MIL)
- T13 YELLOW DOUBLE CENTER (4", 90 MIL)
- T20 WHITE EDGELINE (6", 90 MIL)
- T21 WHITE SOLID LANE LINE (6", 90 MIL)
- T22 10FT. WHITE SKIP (6", 90 MIL)
- T23 3FT.-9FT./SP WHITE MINISKIP (6", 90 MIL)
- T24 2 FT.-6FT./SP WHITE MINISKIP (6", 90 MIL)
- T30 YELLOW EDGELINE (6", 90 MIL)
- T34 2 FT.-6FT./SP YELLOW MINISKIP (6", 90 MIL)
- T50 WHITE GORELINE (12", 90 MIL)
- T51 WHITE DIAGONAL (12", 90 MIL)
- T52 YELLOW DIAGONAL (12", 90 MIL)
- T61 WHITE STOPBAR (24", 90 MIL)
- T103 24" YIELD LINE TRIANGLE (90 MIL)

THERMOPLASTIC SYMBOLS

- T70 LEFT TURN ARROW (90 MIL)
- T71 RIGHT TURN ARROW (90 MIL)
- T77 U-TURN ARROW (90 MIL)

SNOWPLOWABLE
POLYCARBONATE H-SHAPED MARKERS

MF CRYSTAL & RED

NAD 83/NA 2011

TIP NO. HS-2401P	SHEET NO. PMP-3
<small>DocuSigned by:</small> APPROVED: _____ <small>098183F2B2E5741E...</small>	
DATE: 2/25/2026	
SEAL 	
DOCUMENT NOT CONSIDERED FINAL UNLESS ALL SIGNATURES COMPLETED	

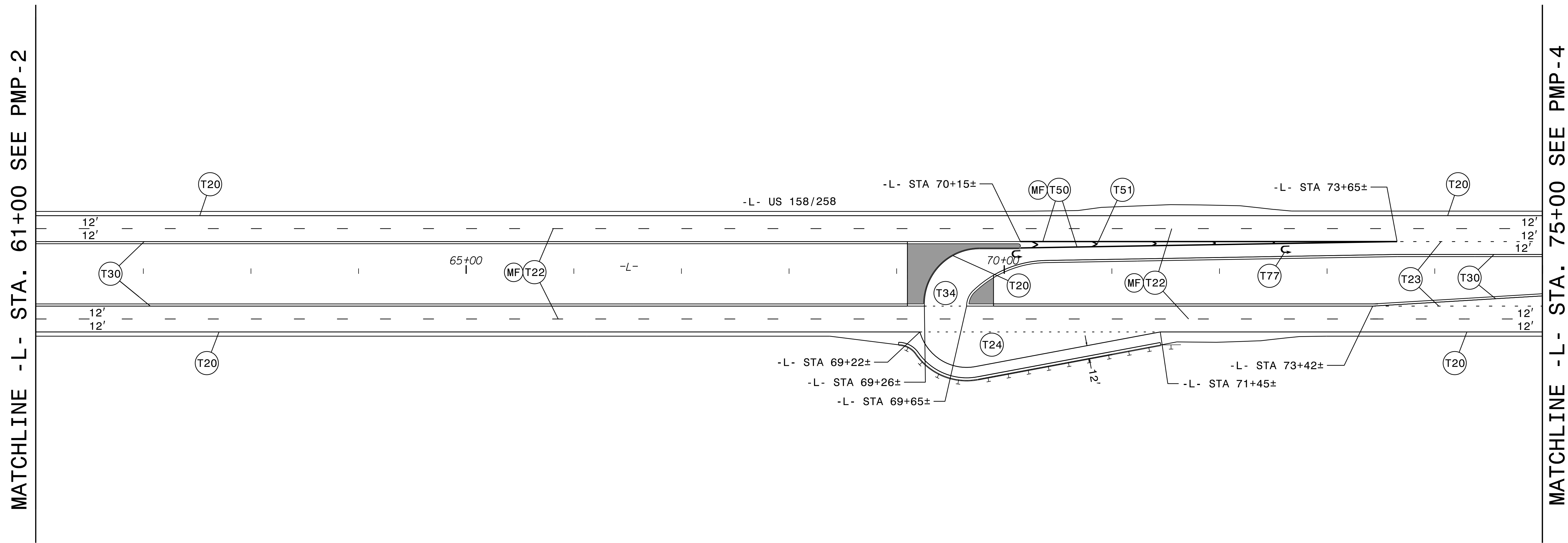

2/13/2026 10:52:40L PMP_P5H03.dgn

RK&K
 P (919) 878-9560
 8601 Six Forks Road, Forum 1, Suite 700
 Raleigh, North Carolina 27615-3960
 NC License No. F-0112

Engineers | Construction Managers | Planners | Scientists
 www.rkk.com

Responsive People | Creative Solutions

PAVEMENT MARKING DETAIL

PAVEMENT MARKING SCHEDULE

THERMOPLASTIC LINES

- T1 WHITE EDGELINE (4", 90 MIL)
- T10 YELLOW EDGELINE (4", 90 MIL)
- T13 YELLOW DOUBLE CENTER (4", 90 MIL)
- T20 WHITE EDGELINE (6", 90 MIL)
- T21 WHITE SOLID LANE LINE (6", 90 MIL)
- T22 10FT. WHITE SKIP (6", 90 MIL)
- T23 3FT.-9FT./SP WHITE MINISKIP (6", 90 MIL)
- T24 2 FT.-6FT./SP WHITE MINISKIP (6", 90 MIL)
- T30 YELLOW EDGELINE (6", 90 MIL)
- T34 2 FT.-6FT./SP YELLOW MINISKIP (6", 90 MIL)
- T50 WHITE GORELINE (12", 90 MIL)
- T51 WHITE DIAGONAL (12", 90 MIL)
- T52 YELLOW DIAGONAL (12", 90 MIL)
- T61 WHITE STOPBAR (24", 90 MIL)
- T103 24" YIELD LINE TRIANGLE (90 MIL)

THERMOPLASTIC SYMBOLS

- T70 LEFT TURN ARROW (90 MIL)
- T71 RIGHT TURN ARROW (90 MIL)
- T77 U-TURN ARROW (90 MIL)

SNOWPLOWABLE POLYCARBONATE H-SHAPED MARKERS

MF CRYSTAL & RED

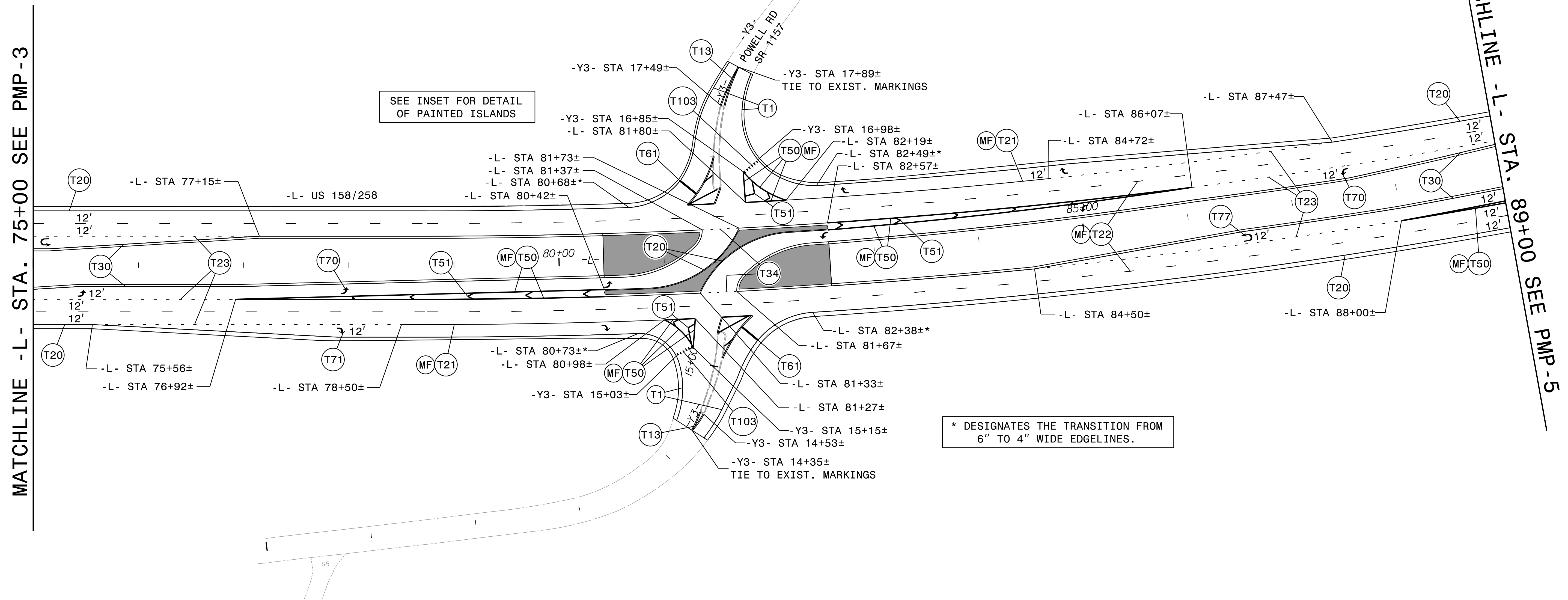
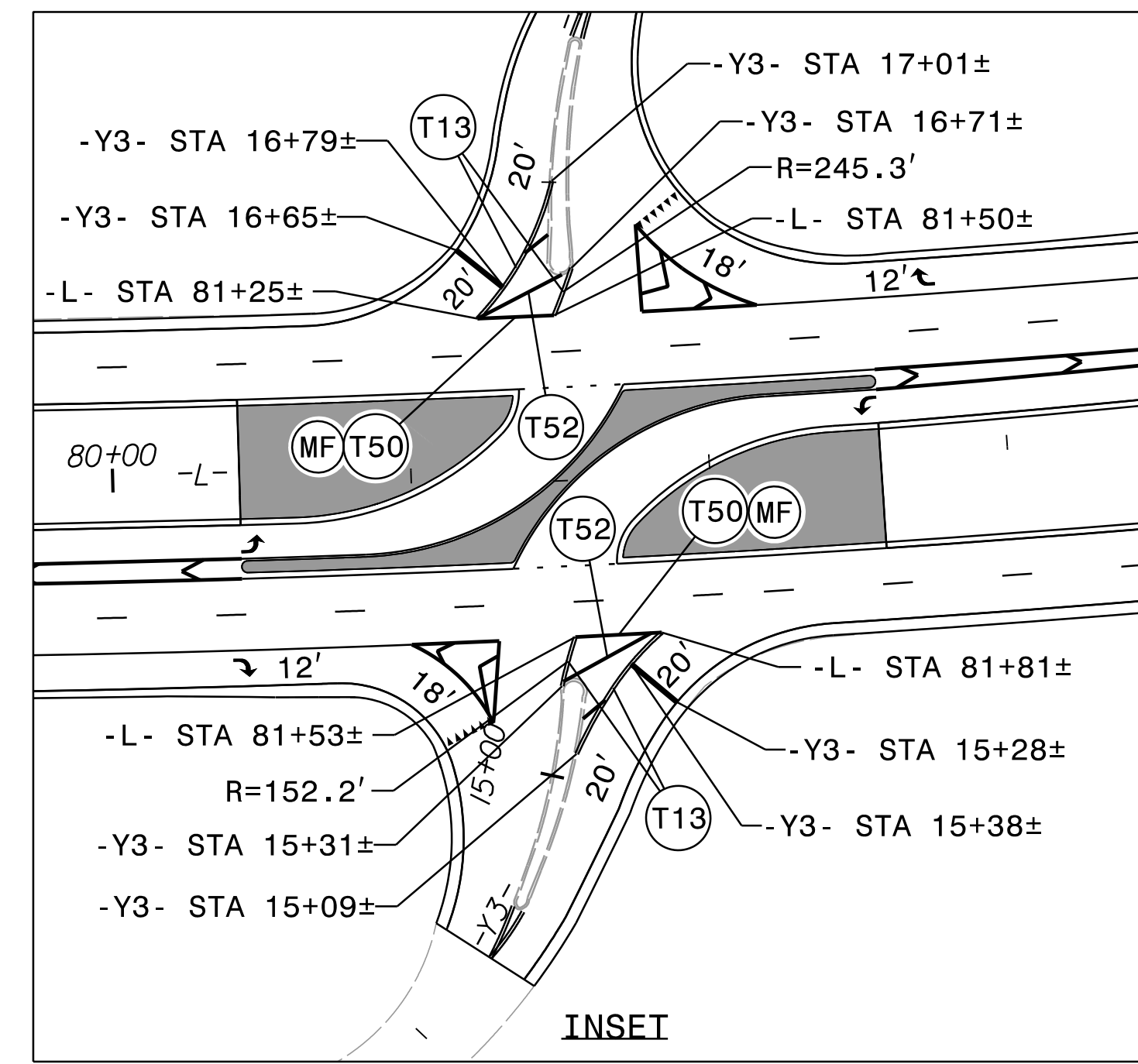
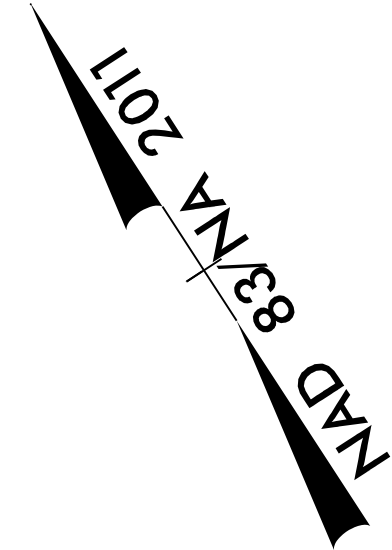

SEE INSET FOR DETAIL
OF PAINTED ISLANDS

* DESIGNATES THE TRANSITION FROM
6" TO 4" WIDE EDGELINES.

TIP NO. HS-2401P	SHEET NO. PMP - 4
APPROVED: <i>David J. Sears</i> DATE: 3/27/2026	
SEAL NORTH CAROLINA PROFESSIONAL ENGINEER SEAL 044558 DAVID T. SEARS	
DOCUMENT NOT CONSIDERED FINAL UNLESS ALL SIGNATURES COMPLETED	

MATCHLINE -L- STA. 75+00 SEE PMP -3

MATCHLINE -L- STA. 89+00 SEE PMP -5

RK&K
P: (919) 878-9560
8601 Six Forks Road, Forum 1, Suite 700
Raleigh, North Carolina 27615-3960
NC License No. F-0112

Engineers | Construction Managers | Planners | Scientists
www.rkk.com

Responsive People | Creative Solutions

PAVEMENT MARKING DETAIL

3/27/2026
US-2401_PMP_PSH04.dgn
User: ds

PAVEMENT MARKING SCHEDULE

THERMOPLASTIC LINES

- T1 WHITE EDGELINE (4", 90 MIL)
- T10 YELLOW EDGELINE (4", 90 MIL)
- T13 YELLOW DOUBLE CENTER (4", 90 MIL)
- T20 WHITE EDGELINE (6", 90 MIL)
- T21 WHITE SOLID LANE LINE (6", 90 MIL)
- T22 10FT. WHITE SKIP (6", 90 MIL)
- T23 3FT.-9FT./SP WHITE MINISKIP (6", 90 MIL)
- T24 2 FT.-6FT./SP WHITE MINISKIP (6", 90 MIL)
- T30 YELLOW EDGELINE (6", 90 MIL)
- T34 2 FT.-6FT./SP YELLOW MINISKIP (6", 90 MIL)
- T50 WHITE GORELINE (12", 90 MIL)
- T51 WHITE DIAGONAL (12", 90 MIL)
- T52 YELLOW DIAGONAL (12", 90 MIL)
- T61 WHITE STOPBAR (24", 90 MIL)
- T103 24" YIELD LINE TRIANGLE (90 MIL)

THERMOPLASTIC SYMBOLS

- T70 LEFT TURN ARROW (90 MIL)
- T71 RIGHT TURN ARROW (90 MIL)
- T77 U-TURN ARROW (90 MIL)

- SNOWPLOWABLE
- POLYCARBONATE H-SHAPED MARKERS
- MF CRYSTAL & RED

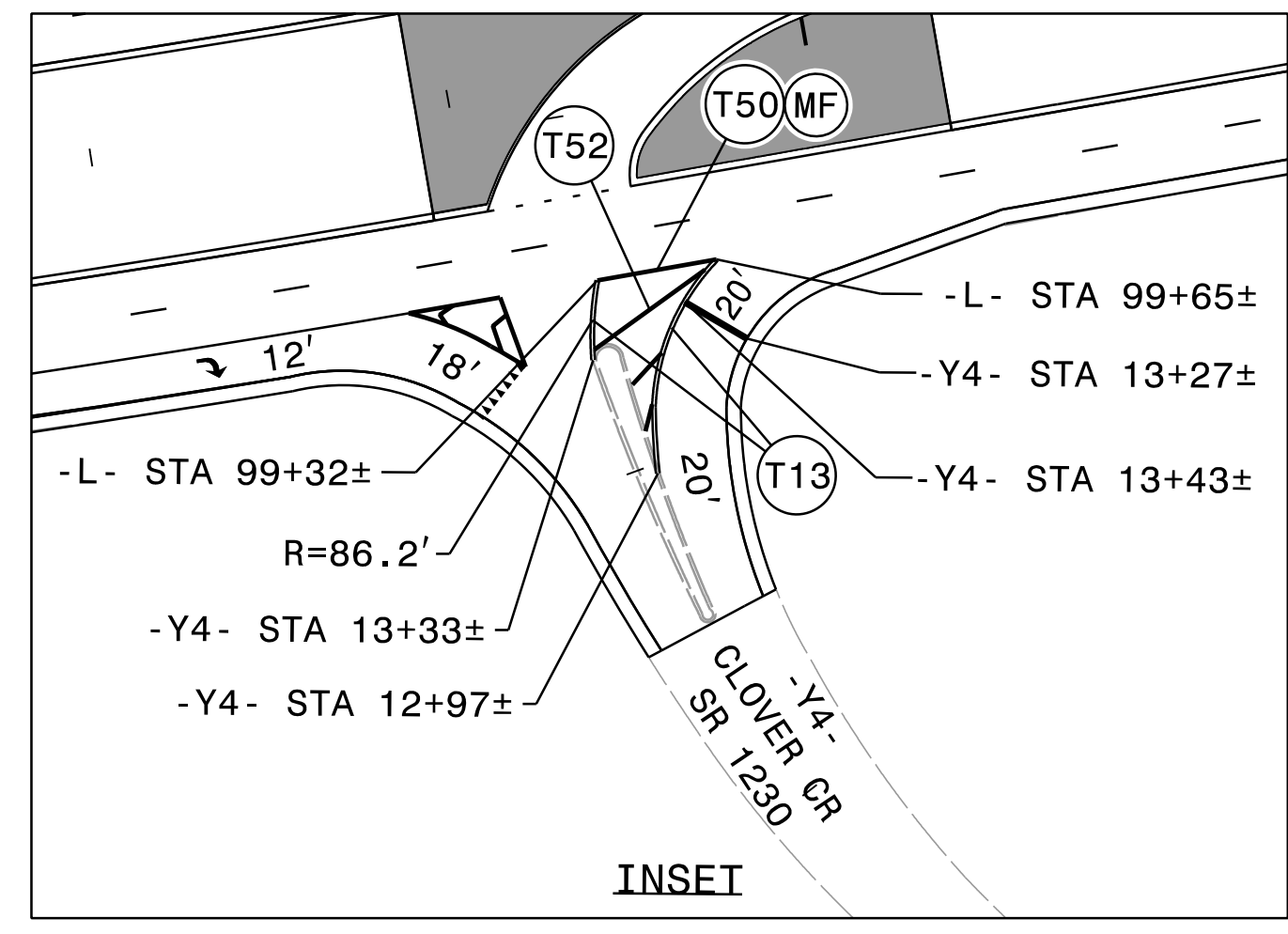
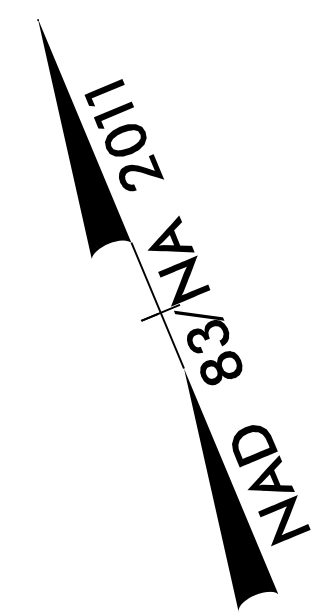

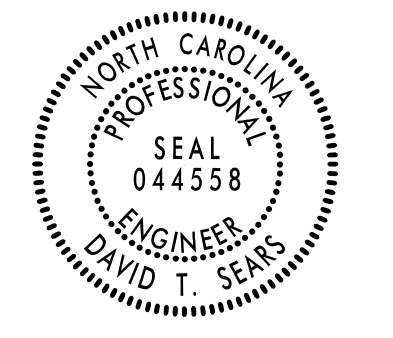
TIP NO. HS-2401P	SHEET NO. PMP-5
<small>Designed by:</small> APPROVED: <i>David J. Sears</i> <small>0981832828741E...</small>	
DATE: 2/25/2026	
SEAL  DAVID T. SEARS	
DOCUMENT NOT CONSIDERED FINAL UNLESS ALL SIGNATURES COMPLETED	

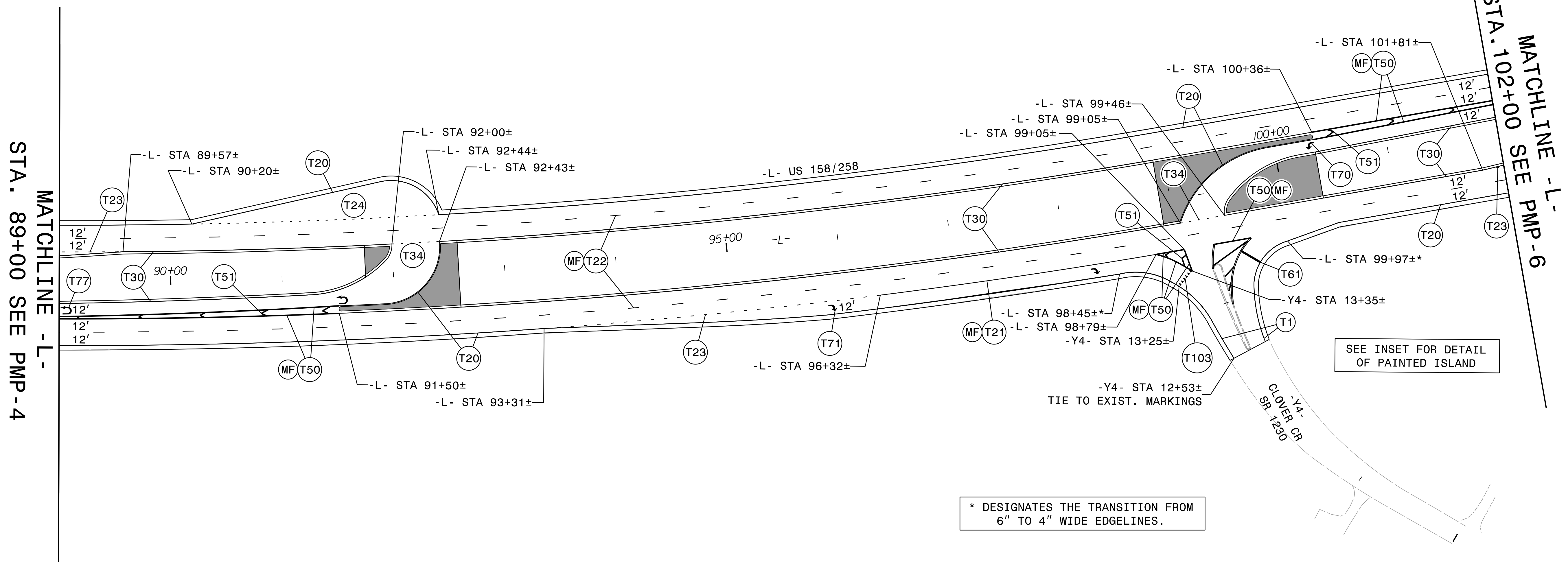

2/13/2026
HS-2401 PMP_PSH05.dgn
User: s



P: (919) 878-9560
8601 Six Forks Road, Forum 1, Suite 700
Raleigh, North Carolina 27615-3960
NC License No. F-0112

Engineers | Construction Managers | Planners | Scientists
www.rkk.com

Responsive People | Creative Solutions

PAVEMENT MARKING DETAIL

PAVEMENT MARKING SCHEDULE

THERMOPLASTIC LINES

- T1 WHITE EDGELINE (4", 90 MIL)
- T10 YELLOW EDGELINE (4", 90 MIL)
- T13 YELLOW DOUBLE CENTER (4", 90 MIL)
- T20 WHITE EDGELINE (6", 90 MIL)
- T21 WHITE SOLID LANE LINE (6", 90 MIL)
- T22 10FT. WHITE SKIP (6", 90 MIL)
- T23 3FT.-9FT./SP WHITE MINISKIP (6", 90 MIL)
- T24 2 FT.-6FT./SP WHITE MINISKIP (6", 90 MIL)
- T30 YELLOW EDGELINE (6", 90 MIL)
- T34 2 FT.-6FT./SP YELLOW MINISKIP (6", 90 MIL)
- T50 WHITE GORELINE (12", 90 MIL)
- T51 WHITE DIAGONAL (12", 90 MIL)
- T52 YELLOW DIAGONAL (12", 90 MIL)
- T61 WHITE STOPBAR (24", 90 MIL)
- T103 24" YIELD LINE TRIANGLE (90 MIL)

THERMOPLASTIC SYMBOLS

- T70 LEFT TURN ARROW (90 MIL)
- T71 RIGHT TURN ARROW (90 MIL)
- T77 U-TURN ARROW (90 MIL)

- SNOWPLOWABLE
- POLYCARBONATE H-SHAPED MARKERS
- MF CRYSTAL & RED

TIP NO. HS-2401P	SHEET NO. PMP-6
<small>DocuSigned by:</small> APPROVED: _____ <small>098183F28E5741E...</small> DATE: 2/25/2026	
SEAL 	
DOCUMENT NOT CONSIDERED FINAL UNLESS ALL SIGNATURES COMPLETED	

NAD 83/NA 2011

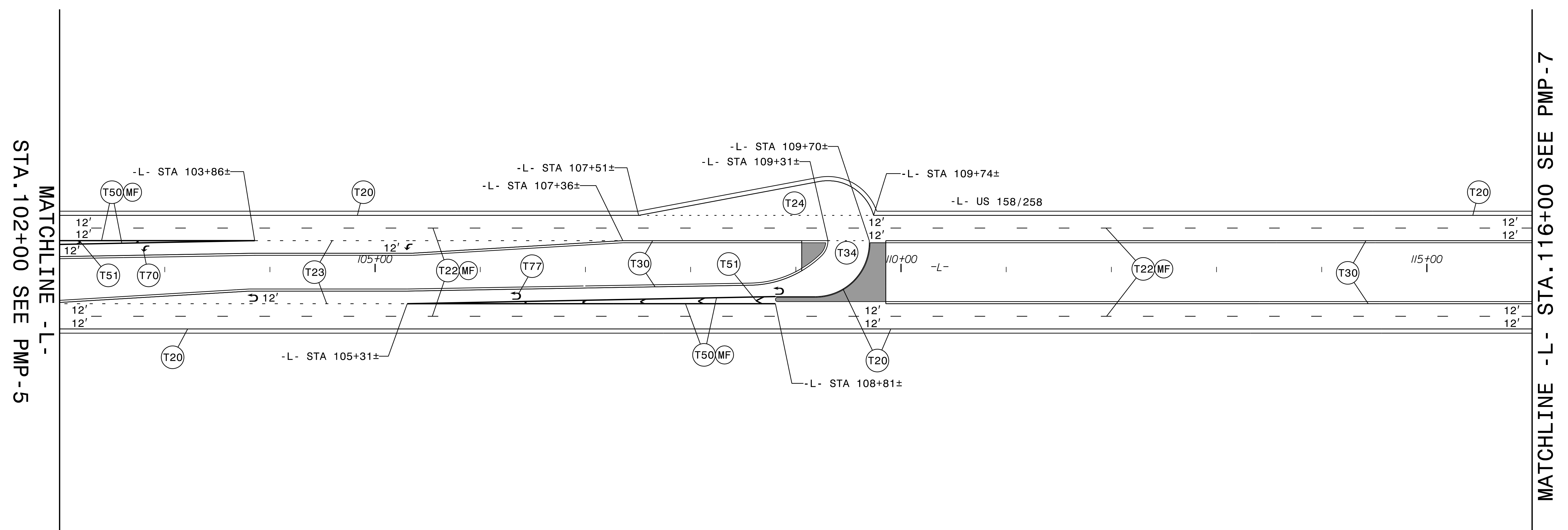

MATCHLINE -L- STA. 102+00 SEE PMP-5

MATCHLINE -L- STA. 116+00 SEE PMP-7

2/13/2026 10:52:40L PMP_P5H06.dgn

P: (919) 878-9560
 8601 Six Forks Road, Forum 1, Suite 700
 Raleigh, North Carolina 27615-3960
 NC License No. F-0112
 Engineers | Construction Managers | Planners | Scientists
 www.rkk.com
 Responsive People | Creative Solutions

PAVEMENT MARKING DETAIL

PAVEMENT MARKING SCHEDULE

THERMOPLASTIC LINES

- T1 WHITE EDGELINE (4", 90 MIL)
- T10 YELLOW EDGELINE (4", 90 MIL)
- T13 YELLOW DOUBLE CENTER (4", 90 MIL)
- T20 WHITE EDGELINE (6", 90 MIL)
- T21 WHITE SOLID LANE LINE (6", 90 MIL)
- T22 10FT. WHITE SKIP (6", 90 MIL)
- T23 3FT.-9FT./SP WHITE MINISKIP (6", 90 MIL)
- T24 2 FT.-6FT./SP WHITE MINISKIP (6", 90 MIL)
- T30 YELLOW EDGELINE (6", 90 MIL)
- T34 2 FT.-6FT./SP YELLOW MINISKIP (6", 90 MIL)
- T50 WHITE GORELINE (12", 90 MIL)
- T51 WHITE DIAGONAL (12", 90 MIL)
- T52 YELLOW DIAGONAL (12", 90 MIL)
- T61 WHITE STOPBAR (24", 90 MIL)
- T103 24" YIELD LINE TRIANGLE (90 MIL)

THERMOPLASTIC SYMBOLS

- T70 LEFT TURN ARROW (90 MIL)
- T71 RIGHT TURN ARROW (90 MIL)
- T77 U-TURN ARROW (90 MIL)

SNOWPLOWABLE
POLYCARBONATE H-SHAPED MARKERS

MF CRYSTAL & RED

NAD 83/NA 2011

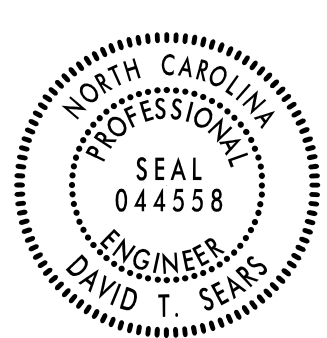
TIP NO. HS-2401P	SHEET NO. PMP-7
<small>Designed by:</small> APPROVED: <i>David J. Sears</i> <small>0981832828741E...</small>	
DATE: 2/25/2026	
	
DOCUMENT NOT CONSIDERED FINAL UNLESS ALL SIGNATURES COMPLETED	

MATCHLINE - L- STA. 116+00 SEE PMP-6

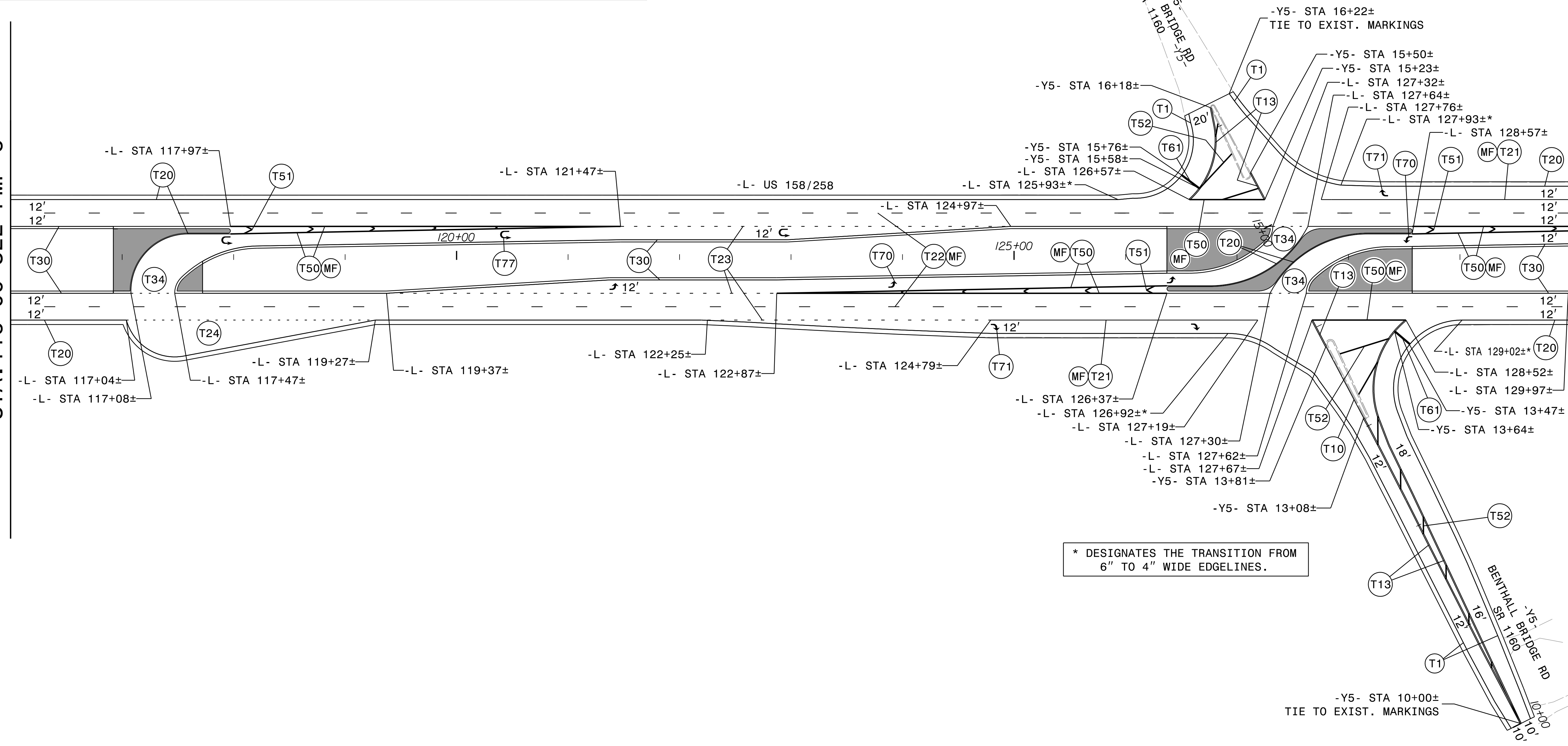

* DESIGNATES THE TRANSITION FROM 6" TO 4" WIDE EDGELINES.

MATCHLINE - L- STA. 130+00 SEE PMP-8

PAVEMENT MARKING DETAIL

2/13/2026 10:24:01 PMP_PSH07.dgn



P: (919) 878-9560
 8601 Six Forks Road, Forum 1, Suite 700
 Raleigh, North Carolina 27615-3960
 NC License No. F-0112
 Engineers | Construction Managers | Planners | Scientists
 www.rkk.com
 Responsive People | Creative Solutions

PAVEMENT MARKING SCHEDULE

THERMOPLASTIC LINES

- T1 WHITE EDGELINE (4", 90 MIL)
- T10 YELLOW EDGELINE (4", 90 MIL)
- T13 YELLOW DOUBLE CENTER (4", 90 MIL)
- T20 WHITE EDGELINE (6", 90 MIL)
- T21 WHITE SOLID LANE LINE (6", 90 MIL)
- T22 10FT. WHITE SKIP (6", 90 MIL)
- T23 3FT.-9FT./SP WHITE MINISKIP (6", 90 MIL)
- T24 2 FT.-6FT./SP WHITE MINISKIP (6", 90 MIL)
- T30 YELLOW EDGELINE (6", 90 MIL)
- T34 2 FT.-6FT./SP YELLOW MINISKIP (6", 90 MIL)
- T50 WHITE GORELINE (12", 90 MIL)
- T51 WHITE DIAGONAL (12", 90 MIL)
- T52 YELLOW DIAGONAL (12", 90 MIL)
- T61 WHITE STOPBAR (24", 90 MIL)
- T103 24" YIELD LINE TRIANGLE (90 MIL)

THERMOPLASTIC SYMBOLS

- T70 LEFT TURN ARROW (90 MIL)
- T71 RIGHT TURN ARROW (90 MIL)
- T77 U-TURN ARROW (90 MIL)

SNOWPLOWABLE
POLYCARBONATE H-SHAPED MARKERS

MF CRYSTAL & RED

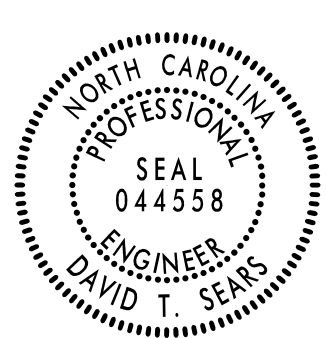
TIP NO. HS-2401P	SHEET NO. PMP-8
APPROVED: <i>David T. Sears</i> <small>098183F28E5741E...</small>	
DATE: 2/25/2026	
	
DOCUMENT NOT CONSIDERED FINAL UNLESS ALL SIGNATURES COMPLETED	

NAD 83/NA 2011

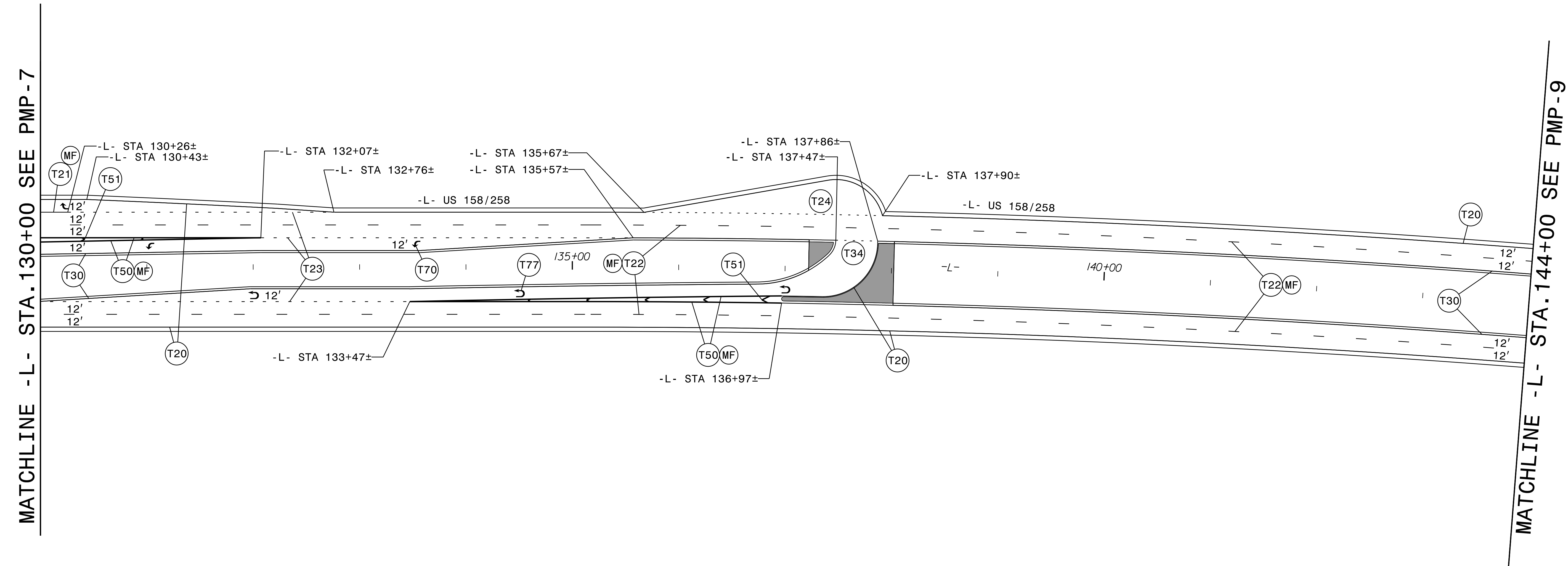

2/13/2026
HS-2401-PMP_PSH08.dgn
Use Only



P: (919) 878-9560
8601 Six Forks Road, Forum 1, Suite 700
Raleigh, North Carolina 27615-3960
NC License No. F-0112

Engineers | Construction Managers | Planners | Scientists
www.rkk.com

Responsive People | Creative Solutions

PAVEMENT MARKING DETAIL

PAVEMENT MARKING SCHEDULE

THERMOPLASTIC LINES

- T1 WHITE EDGELINE (4", 90 MIL)
- T10 YELLOW EDGELINE (4", 90 MIL)
- T13 YELLOW DOUBLE CENTER (4", 90 MIL)
- T20 WHITE EDGELINE (6", 90 MIL)
- T21 WHITE SOLID LANE LINE (6", 90 MIL)
- T22 10FT. WHITE SKIP (6", 90 MIL)
- T23 3FT.-9FT./SP WHITE MINISKIP (6", 90 MIL)
- T24 2 FT.-6FT./SP WHITE MINISKIP (6", 90 MIL)
- T30 YELLOW EDGELINE (6", 90 MIL)
- T34 2 FT.-6FT./SP YELLOW MINISKIP (6", 90 MIL)
- T50 WHITE GORELINE (12", 90 MIL)
- T51 WHITE DIAGONAL (12", 90 MIL)
- T52 YELLOW DIAGONAL (12", 90 MIL)
- T61 WHITE STOPBAR (24", 90 MIL)
- T103 24" YIELD LINE TRIANGLE (90 MIL)

THERMOPLASTIC SYMBOLS

- T70 LEFT TURN ARROW (90 MIL)
- T71 RIGHT TURN ARROW (90 MIL)
- T77 U-TURN ARROW (90 MIL)

SNOWPLOWABLE
POLYCARBONATE H-SHAPED MARKERS

MF CRYSTAL & RED

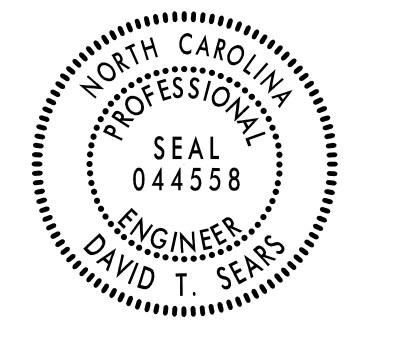
TIP NO. HS-2401P	SHEET NO. PMP-9
APPROVED: <i>David J. Sears</i> <small>DocuSigned by: David J. Sears 098183F2B8E5741E...</small>	
DATE: 2/25/2026	
SEAL 	
DOCUMENT NOT CONSIDERED FINAL UNLESS ALL SIGNATURES COMPLETED	

NAD 83/NA 2011

MATCHLINE -L- STA. 144+00 SEE PMP-8

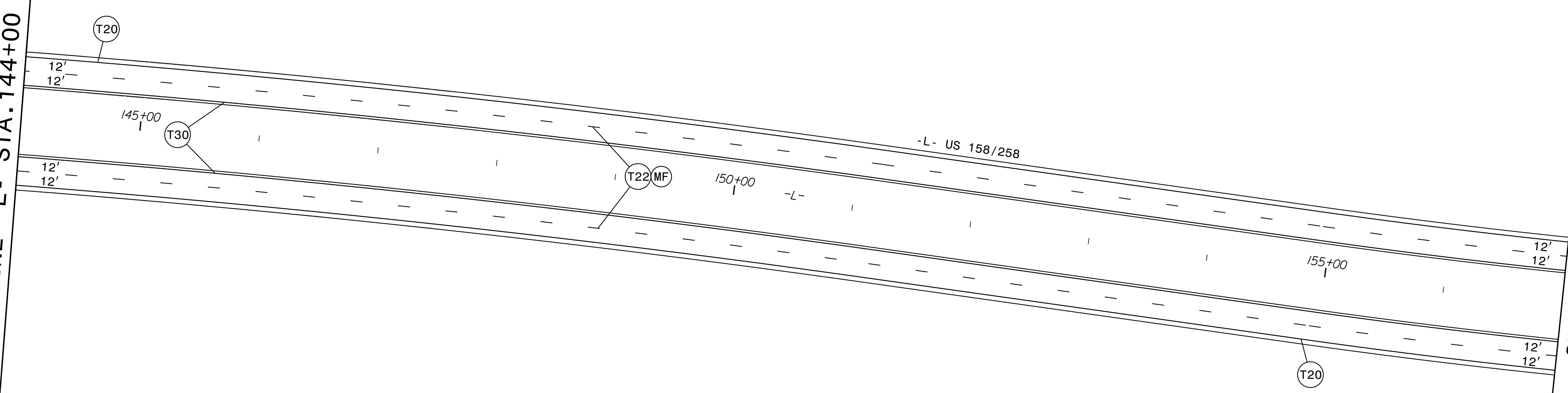

MATCHLINE -L- STA. 157+00 SEE PMP-10

2/13/2026
US-2401_PMP_P5H09.dgn
User: s

RKK
 P: (919) 878-9560
 8601 Six Forks Road, Forum 1, Suite 700
 Raleigh, North Carolina 27615-3960
 NC License No. F-0112
 Engineers | Construction Managers | Planners | Scientists
 www.rkk.com
 Responsive People | Creative Solutions

PAVEMENT MARKING DETAIL

PAVEMENT MARKING SCHEDULE

THERMOPLASTIC LINES

- T1 WHITE EDGELINE (4", 90 MIL)
- T10 YELLOW EDGELINE (4", 90 MIL)
- T13 YELLOW DOUBLE CENTER (4", 90 MIL)
- T20 WHITE EDGELINE (6", 90 MIL)
- T21 WHITE SOLID LANE LINE (6", 90 MIL)
- T22 10FT. WHITE SKIP (6", 90 MIL)
- T23 3FT.-9FT./SP WHITE MINISKIP (6", 90 MIL)
- T24 2 FT.-6FT./SP WHITE MINISKIP (6", 90 MIL)
- T30 YELLOW EDGELINE (6", 90 MIL)
- T34 2 FT.-6FT./SP YELLOW MINISKIP (6", 90 MIL)
- T50 WHITE GORELINE (12", 90 MIL)
- T51 WHITE DIAGONAL (12", 90 MIL)
- T52 YELLOW DIAGONAL (12", 90 MIL)
- T61 WHITE STOPBAR (24", 90 MIL)
- T103 24" YIELD LINE TRIANGLE (90 MIL)

THERMOPLASTIC SYMBOLS

- T70 LEFT TURN ARROW (90 MIL)
- T71 RIGHT TURN ARROW (90 MIL)
- T77 U-TURN ARROW (90 MIL)

SNOWPLOWABLE
POLYCARBONATE H-SHAPED MARKERS

MF CRYSTAL & RED

NAD 83/NA 2011

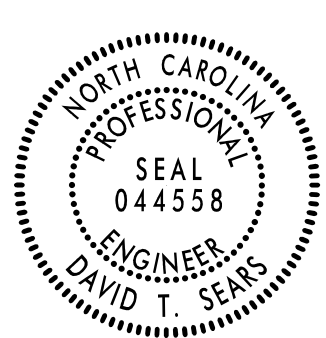
TIP NO. HS-2401P	SHEET NO. PMP-10
<small>DocuSigned by:</small> APPROVED: <i>David T. Sears</i> <small>098183F2B2E5741E...</small>	
DATE: 2/25/2026	
	
DOCUMENT NOT CONSIDERED FINAL UNLESS ALL SIGNATURES COMPLETED	

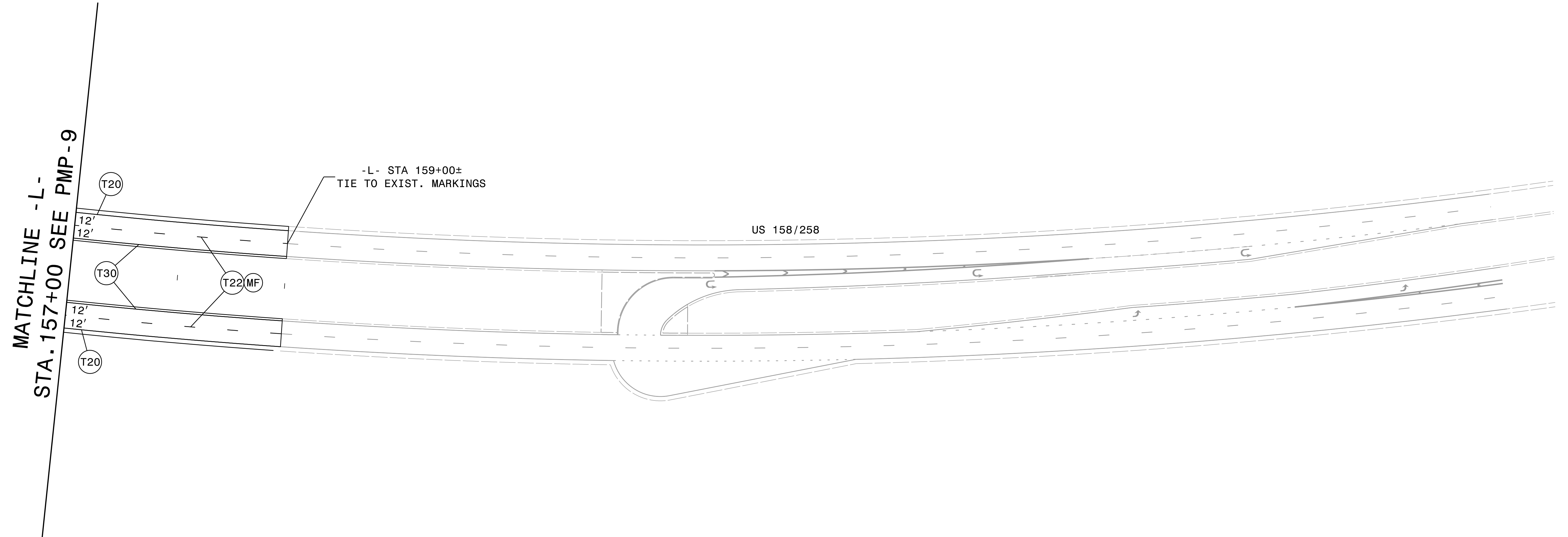

2/13/2026
US-2401_PMP_PSH010.dgn
D:\Sears

RK&K
 P: (919) 878-9560
 8601 Six Forks Road, Forum 1, Suite 700
 Raleigh, North Carolina 27615-3960
 NC License No. F-0112

Engineers | Construction Managers | Planners | Scientists
 www.rkk.com

Responsive People | Creative Solutions

PAVEMENT MARKING DETAIL